

Note:
 1. Opening in pole base plate shall be equal to pole base inside diameter minus 3 1/2" but shall not be less than 8 1/2".

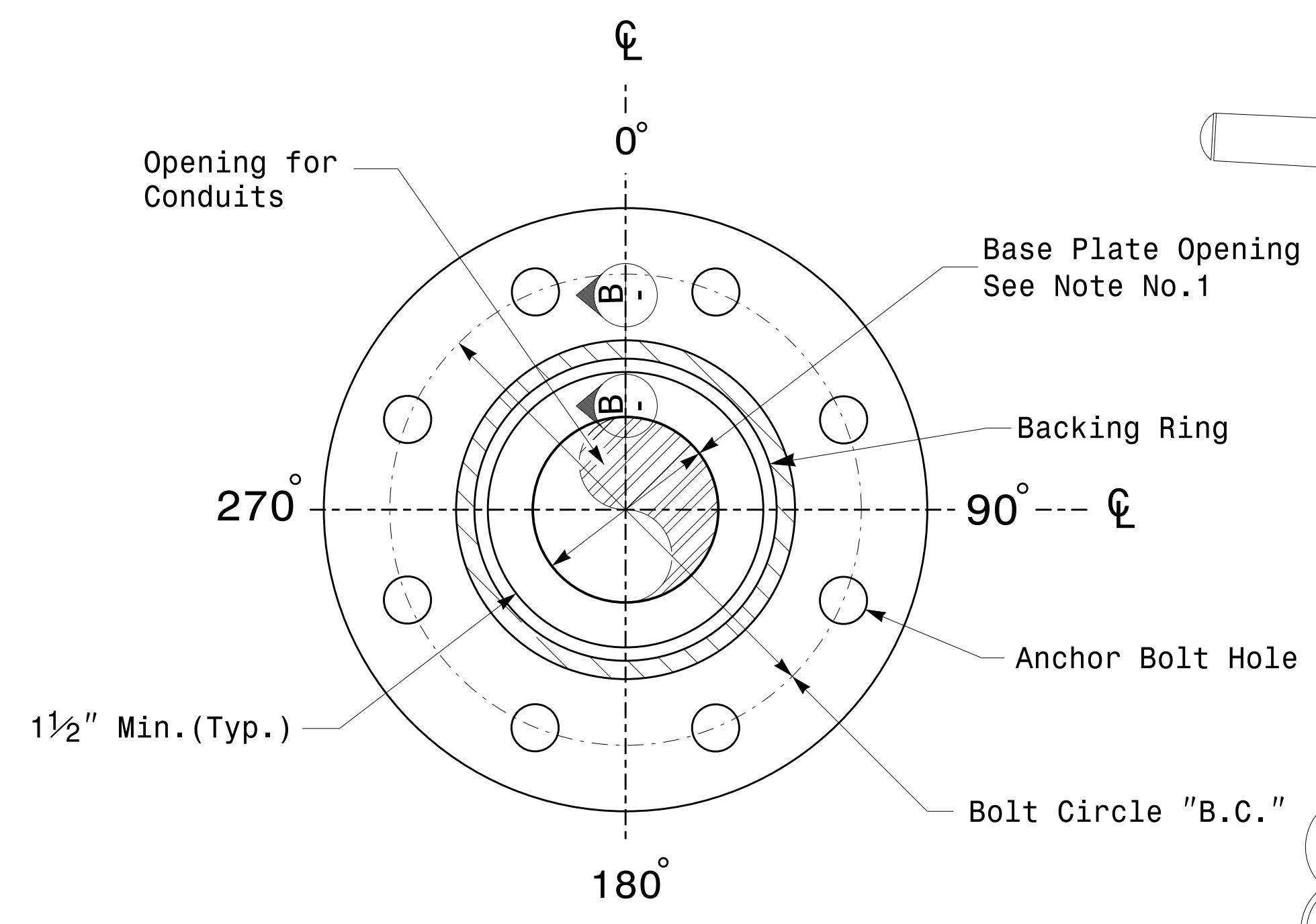

Section A-A
Pole Base Plate Details

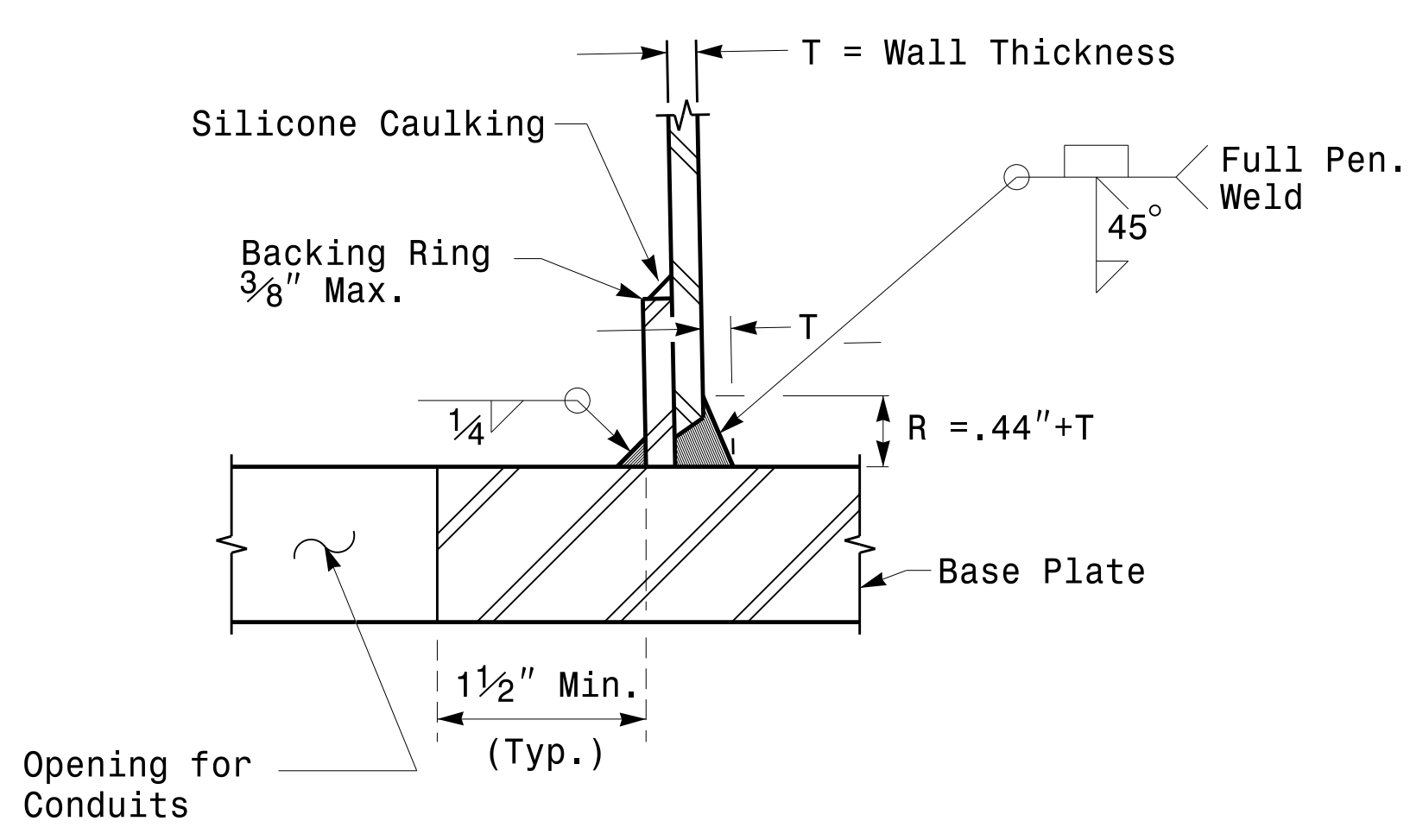

Section B-B
 (Pole Attachment to Base Plate)
Full-Penetration Groove Weld Detail

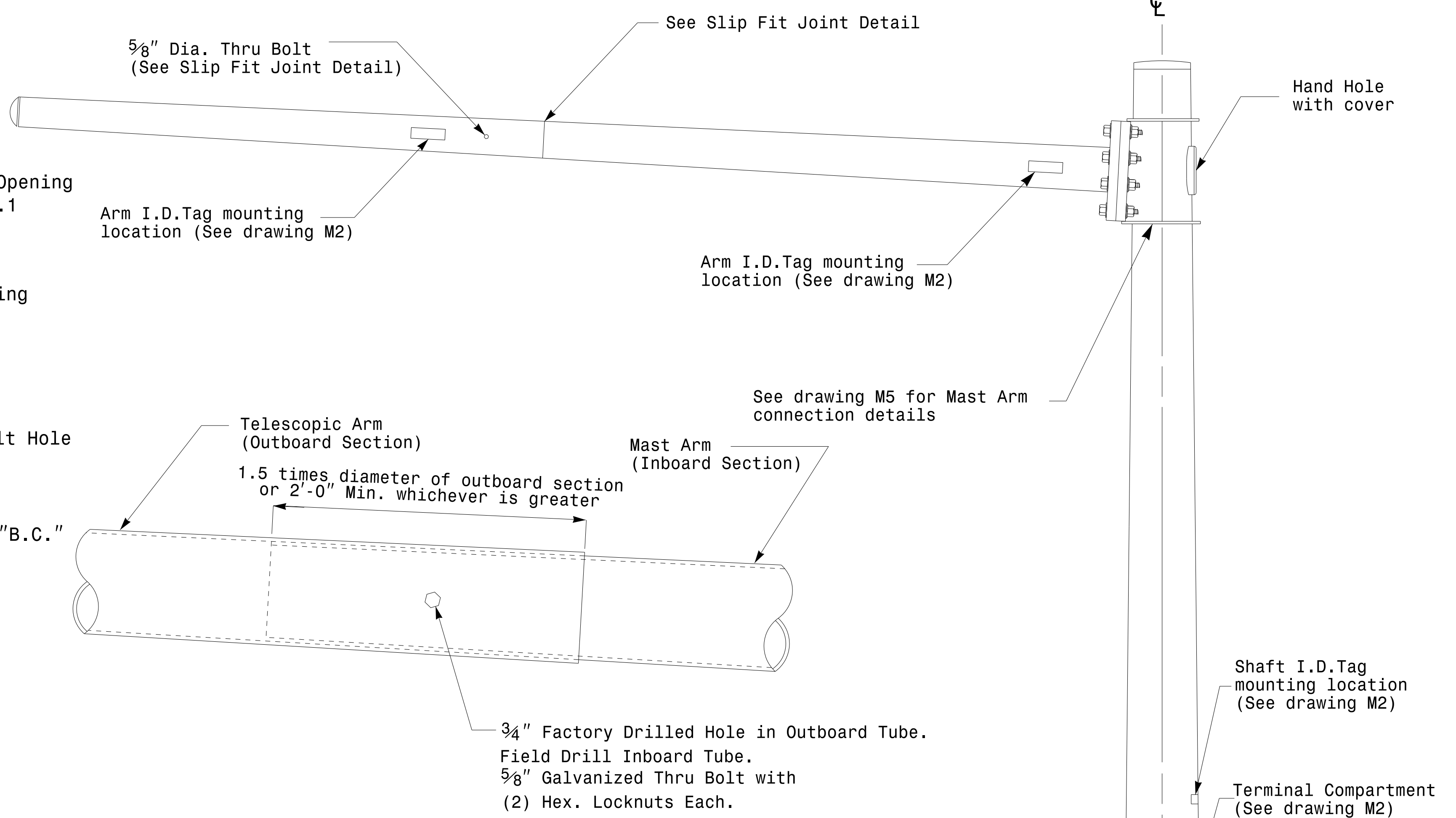

Slip Fit Joint Detail for Mast Arm

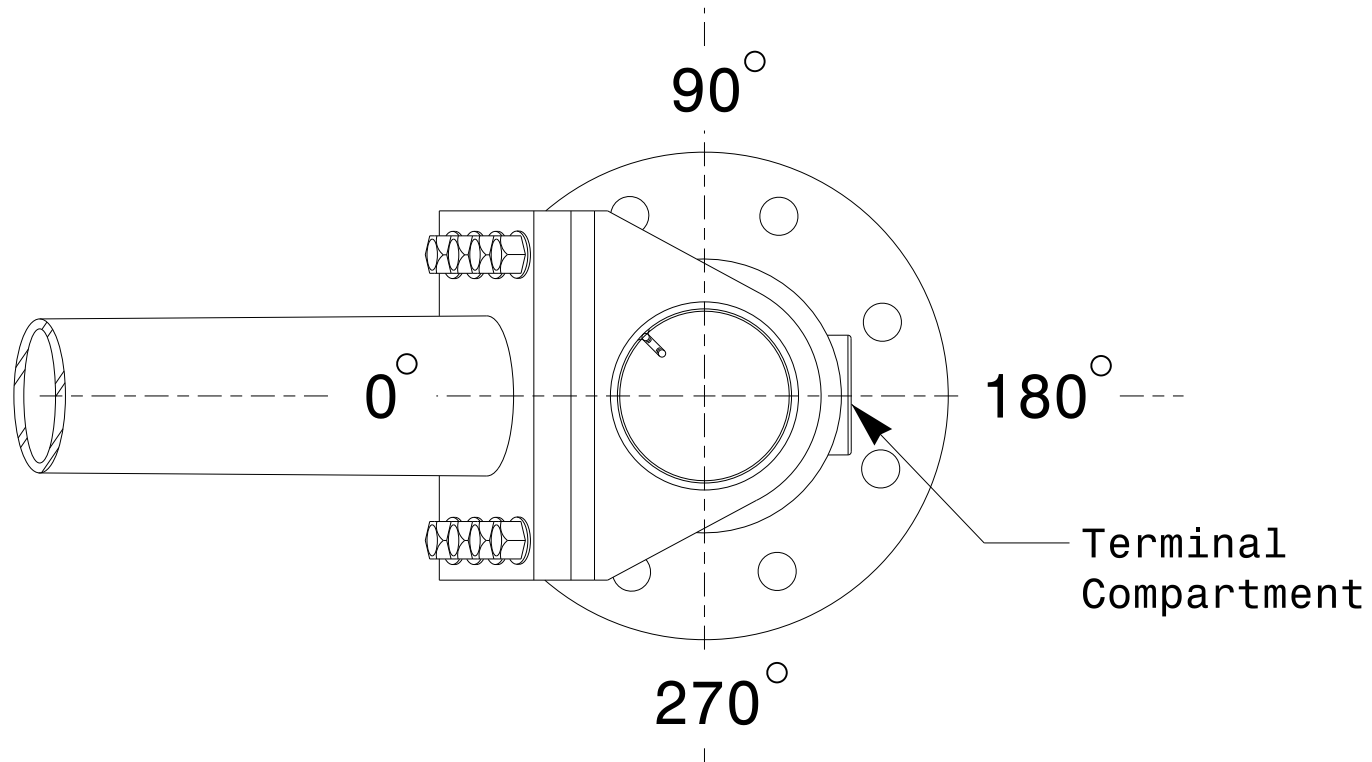

Mast Arm Radial Orientation

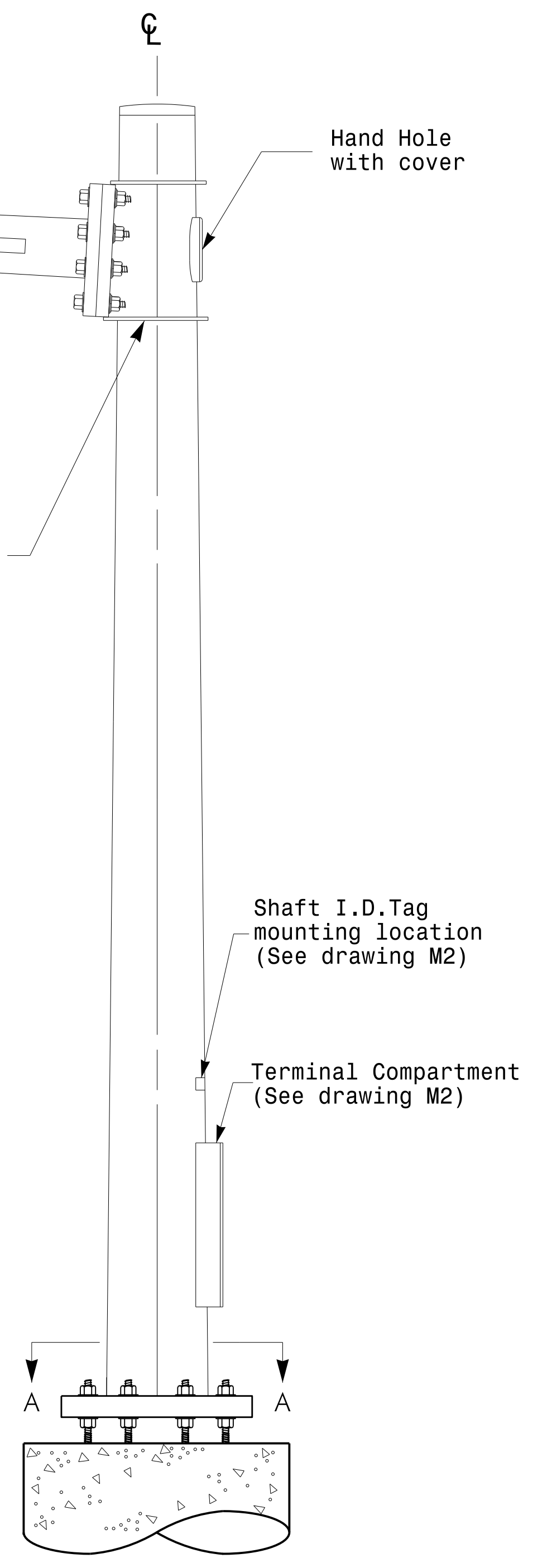

Mast Arm Pole

Fabrication Details - Mast Arm Poles

	Typical Fabrication Details For Mast Arm Poles		SEAL D. C. SARKAR ENGINEER
	PLAN DATE: FEBRUARY 2016 PREPARED BY: N. BITTING	DESIGNED BY: K.C. DURIGON REVIEWED BY: D.C. SARKAR	
SCALE: 0 NA NONE	REVISIONS:	INIT.:	DATE:
DocuSigned by 44E8E32E147E4C4...			DATE:

17-FEB-2016 16:05
 U:\CSG\W115\Signal\sig\Design\Section\Eastern_Region\M4_Sheets\2016\2014_Sig_M4_Std_Fabrication_Details\Mast_Arm_Poles.dgn
 3:01:02 PM