

**This electronic collection of documents is provided
for the convenience of the user
and is Not a Certified Document –**

**The documents contained herein were originally issued
and sealed by the individuals whose names and license
numbers appear on each page, on the dates appearing
with their signature on that page.**

**This file or an individual page
shall not be considered a certified document.**

TIP NO.	SHEET NO.
U-4751	PMP-1
APPROVED: <i>Andrew D. Klinksiek</i> <small>E3D78F84596E44B...</small>	
DATE: 7/5/2017	
SEAL	
	
DOCUMENT NOT CONSIDERED FINAL UNLESS ALL SIGNATURES COMPLETED	

**STATE OF NORTH CAROLINA
DEPARTMENT OF TRANSPORTATION**

**PAVEMENT MARKING PLAN
NEW HANOVER COUNTY**

T.I.P.: U-4751

CONTRACT: C203980

INDEX

SHEET NO.	DESCRIPTION
PMP-1	PAVEMENT MARKING PLAN COVER SHEET
PMP-1A	FINAL PAVEMENT MARKING SCHEDULE AND LEGEND
PMP-2	CROSSWALK PAVEMENT MARKING GUIDANCE DETAIL
PMP-2A	LANE DROPS
PMP-3 THRU PMP-39	PAVEMENT MARKING DETAIL

ROADWAY STANDARD DRAWING

THE FOLLOWING ROADWAY STANDARDS AS APPEAR IN "ROADWAY STANDARD DRAWINGS" - PROJECT SERVICES UNIT - N.C. DEPARTMENT OF TRANSPORTATION - RALEIGH, N.C., DATED JANUARY 2012 ARE APPLICABLE TO THIS PROJECT AND BY REFERENCE HEREBY ARE CONSIDERED A PART OF THESE PLANS:

STD. NO.	TITLE
1205.01	PAVEMENT MARKINGS - LINE TYPES AND OFFSETS
1205.02	PAVEMENT MARKINGS - TWO-LANE AND MULTILANE ROADWAYS
1205.03	PAVEMENT MARKINGS - EXIT AND ENTRANCE RAMP
1205.04	PAVEMENT MARKINGS - INTERSECTIONS
1205.05	PAVEMENT MARKINGS - TURN LANES
1205.06	PAVEMENT MARKINGS - LANE DROPS
1205.08	PAVEMENT MARKINGS - SYMBOLS AND WORD MESSAGES
1205.09	PAVEMENT MARKINGS - PAINTED ISLANDS
1205.12	PAVEMENT MARKINGS - BRIDGES
1205.13	PAVEMENT MARKINGS - LANE REDUCTIONS
1250.01	RAISED PAVEMENT MARKERS - INSTALLATION SPACING
1251.01	RAISED PAVEMENT MARKERS - PERMANENT AND TEMPORARY
1253.01	RAISED PAVEMENT MARKERS - SNOWPLOWABLE
1261.01	GUARDRAIL AND BARRIER DELINEATORS - INSTALLATION SPACING
1261.02	GUARDRAIL AND BARRIER DELINEATORS - TYPES AND MOUNTING
1262.01	GUARDRAIL END DELINEATION
1264.01	OBJECT MARKERS - TYPES
1264.02	OBJECT MARKERS - INSTALLATION
1267.01	FLEXIBLE DELINEATORS - INSTALLATION
1267.02	FLEXIBLE DELINEATORS - SPACING TABLES
1267.03	FLEXIBLE DELINEATORS - INTERCHANGE PLACEMENT

GENERAL NOTES

THE FOLLOWING GENERAL NOTES APPLY AT ALL TIMES FOR THE DURATION OF THE CONSTRUCTION PROJECT, EXCEPT WHEN OTHERWISE NOTED IN THE PLAN, OR DIRECTED BY THE ENGINEER.

- A) INSTALL PAVEMENT MARKINGS AND PAVEMENT MARKERS ON THE FINAL SURFACE AS FOLLOWS:

ROAD NAME	MARKING	MARKER
-L- MILITARY CUTOFF RD	THERMOPLASTIC W/HIGHLY REFLECTIVE ELEMENTS	SNOWPLOWABLE REFLECTIVE
-Y- LINES	THERMOPLASTIC W/HIGHLY REFLECTIVE ELEMENTS	MATCH EXISTING
BRIDGES	POLYUREA W/ HIGHLY REFLECTIVE ELEMENTS	RAISED REFLECTIVE

- B) TIE PROPOSED PAVEMENT MARKING LINES TO EXISTING PAVEMENT MARKING LINES.
 C) REMOVE/REPLACE ANY CONFLICTING/DAMAGED PAVEMENT MARKINGS AND MARKERS.
 D) PASSING ZONES WILL BE DETERMINED IN THE FIELD AND MUST BE APPROVED BY THE ENGINEER.
 E) STOP BAR LOCATION AT NON-SIGNALIZED INTERSECTIONS MAY BE ADJUSTED AS DIRECTED BY THE ENGINEER.
 F) REMOVE ALL RESIDUE AND SURFACE LAITANCE BY ACCEPTABLE METHODS ON CONCRETE BRIDGE DECKS PRIOR TO PLACING (POLYUREA) PAVEMENT MARKING MATERIAL.
 G) UNLESS OTHERWISE SPECIFIED, HEATED-IN-PLACE THERMOPLASTIC MAY BE USED IN LIEU OF EXTRUDED THERMOPLASTIC FOR STOP BARS, SYMBOLS, CHARACTERS AND DIAGONALS. IF HEATED-IN-PLACE IS USED, IT SHALL BE PAID FOR USING THE EXTRUDED THERMOPLASTIC PAY ITEM.
 H) SEE ROADWAY PLANS FOR ALTERNATE CURB RAMP DESIGNS WHEN INDICATED ON PAVEMENT MARKING DETAIL SHEETS.

PLAN REVIEWED BY: N.C.D.O.T. SIGNING AND DELINEATION UNIT

Ayman Alqudwah, PE, CPM SIGNING & DELINEATION STANDARDS ENGINEER
Mitch Eaton, PE SIGNING & DELINEATION PROJECT DESIGN ENGINEER

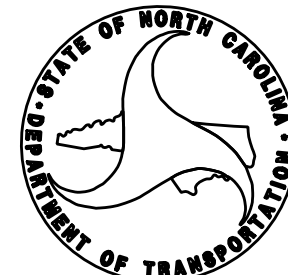

PLAN PREPARED BY: HNTB NORTH CAROLINA, P.C.

A.D. Klinksiek, PE, PTOE PROJECT ENGINEER
J.A. Phillips DESIGN TECHNICIAN

HNTB HNTB NORTH CAROLINA, P.C.
 343 E. Six Forks Road, Suite 200
 Raleigh, North Carolina 27609
 C-1554

TIP NO. U-4751	SHEET NO. PMP-1A
APPROVED: <u>Andrew D. Klinck</u> E3078F84586E44B	
DATE: 7/5/2017	
	
DOCUMENT NOT CONSIDERED FINAL UNLESS ALL SIGNATURES COMPLETED	

FINAL PAVEMENT MARKING SCHEDULE

MATERIAL	SYMBOL	DESCRIPTION
PAVEMENT MARKING		
<u>POLYUREA (4") Highly Reflective Elements</u>		
	VA	WHITE EDGELINE
	VB	YELLOW EDGELINE
	VC	10 FT. WHITE SKIP
<u>POLYUREA (6") Highly Reflective Elements</u>		
	V6	WHITE EDGELINE
	V7	YELLOW EDGELINE
	VJ	10 FT. WHITE SKIP
	VK	3 FT.- 9 FT./SP WHITE MINISKIP
<u>POLYUREA (8") Highly Reflective Elements</u>		
	V13	3 FT. - 9 FT./SP WHITE MINISKIP
<u>THERMOPLASTIC (4", 90 MILS) Highly Reflective Elements</u>		
	TA	WHITE EDGELINE
	TB	YELLOW EDGELINE
<u>THERMOPLASTIC (4", 120 MILS) Highly Reflective Elements</u>		
	T8	WHITE MINI SKIPS (2'/6')
	T9	YELLOW MINI SKIPS (2'/6')
	TC	WHITE SKIP
	TD	WHITE MINISKIP (3'/9')
	TE	WHITE SOLID LANE LINE
	TF	YELLOW SKIP
	TH	YELLOW SINGLE CENTER
	TI	YELLOW DOUBLE CENTER
<u>THERMOPLASTIC (6", 90 MILS) Highly Reflective Elements</u>		
	T6	WHITE EDGELINE
	T7	YELLOW EDGELINE
<u>THERMOPLASTIC (6", 120 MILS) Highly Reflective Elements</u>		
	TJ	WHITE SKIP
	TK	WHITE MINISKIP (3'/9')
<u>THERMOPLASTIC (8", 90 MILS) Highly Reflective Elements</u>		
	TN	WHITE GORELINE
<u>THERMOPLASTIC (8", 120 MILS) Highly Reflective Elements</u>		
	T13	WHITE MINISKIP (3'/9')
	TR	WHITE SOLID LANE LINE
<u>THERMOPLASTIC (12", 90 MILS) Highly Reflective Elements</u>		
	TS	WHITE GORELINE
	TU	WHITE DIAGONAL
	TV	YELLOW DIAGONAL









<u>THERMOPLASTIC (12", 120 MILS) Highly Reflective Elements</u>	
TT	WHITE SOLID LANE LINE
<u>THERMOPLASTIC (24", 120 MILS) Highly Reflective Elements</u>	
T2	WHITE STOPBAR
T3	WHITE CROSSWALK LINE
<u>THERMOPLASTIC PAVEMENT MARKING SYMBOLS(90 MILS)</u>	
UA	LEFT TURN ARROW
UB	RIGHT TURN ARROW
UC	STRAIGHT ARROW
UD	COMBO STRAIGHT/LEFT
UE	COMBO STRAIGHT/RIGHT
UN	24" YIELD LINE TRIANGLE
UP	MERGE ARROW
UT	U-TURN ARROW
<u>THERMOPLASTIC PAVEMENT MARKING CHARACTER(120 MILS)</u>	
UI	ALPHANUMERIC CHAR.
<u>PERMANENT RAISED PAVEMENT MARKERS (NOT SHOWN)</u>	
MB	CRYSTAL & RED
<u>SNOWPLOWABLE PAVEMENT MARKERS (NOT SHOWN)</u>	
ME	YELLOW & YELLOW
MF	CRYSTAL & RED

LEGEND

- GENERAL**
- DIRECTION OF TRAFFIC FLOW
 - NORTH ARROW
 - PROPOSED PVMT. EXIST. PVMT.

- PAVEMENT MARKINGS**
- PAVEMENT MARKING SYMBOLS

PAVEMENT MARKING SYMBOLS

	UA
	UB
	UC
	UD
	UE
ONLY	UI
	UN
	UP
	UT

HNTB HNTB NORTH CAROLINA, P.C.
343 E. SIX FORKS ROAD, SUITE 200
RALEIGH, NORTH CAROLINA 27609
NC License No: C-1554
(919) 546-8997

PAVEMENT MARKING SCHEDULE AND LEGEND

7/5/2017
PMP-U4751_PMP_01-1A.dgn
HNTB

TIP NO.	SHEET NO.
U-4751	PMP-2
APPROVED: <i>Andrew D. Klinowski</i> E3078FB458644B	
DATE: 7/5/2017	
SEAL	
	
DOCUMENT NOT CONSIDERED FINAL UNLESS ALL SIGNATURES COMPLETED	

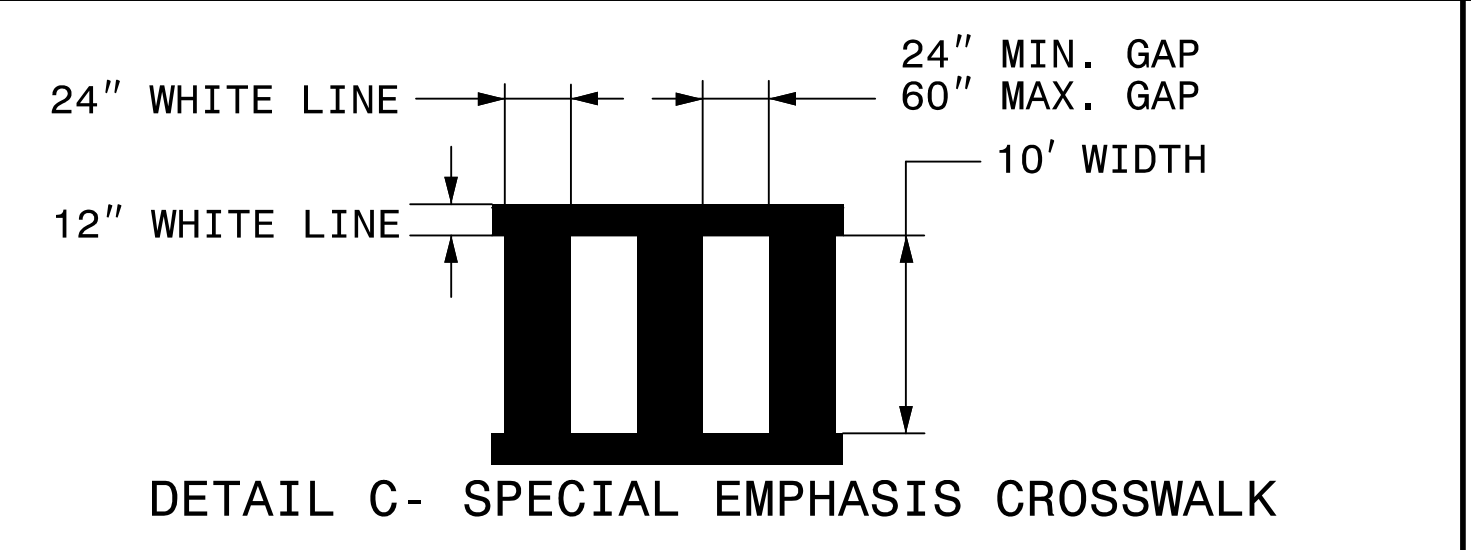

ALL SIGNALIZED PEDESTRIAN CROSSWALKS SHALL BE SPECIAL EMPHASIS CROSSWALKS AS SPECIFIED IN NCDOT DIVISION 3 HIGH-VISIBILITY CROSSWALK POLICY.

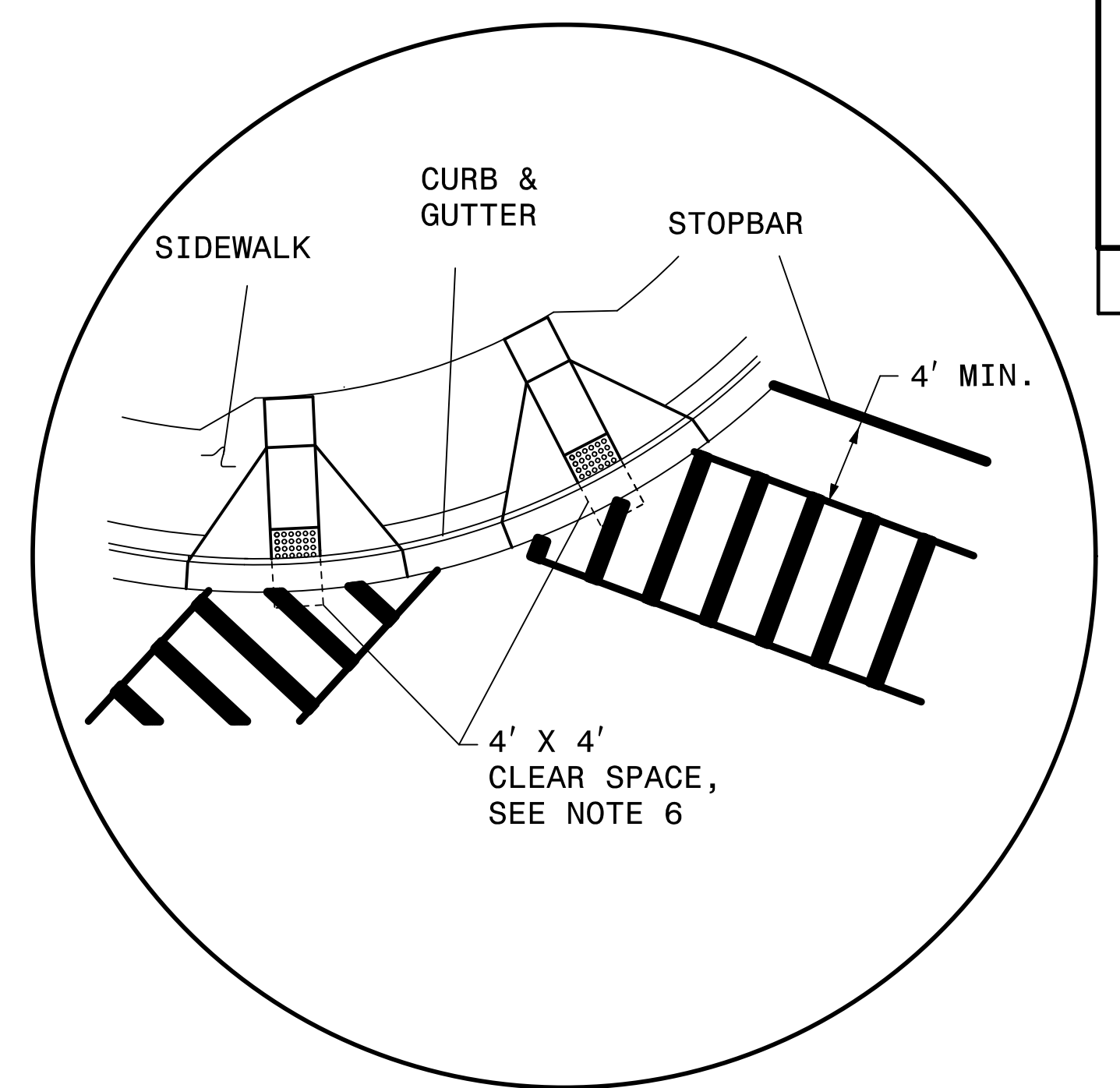
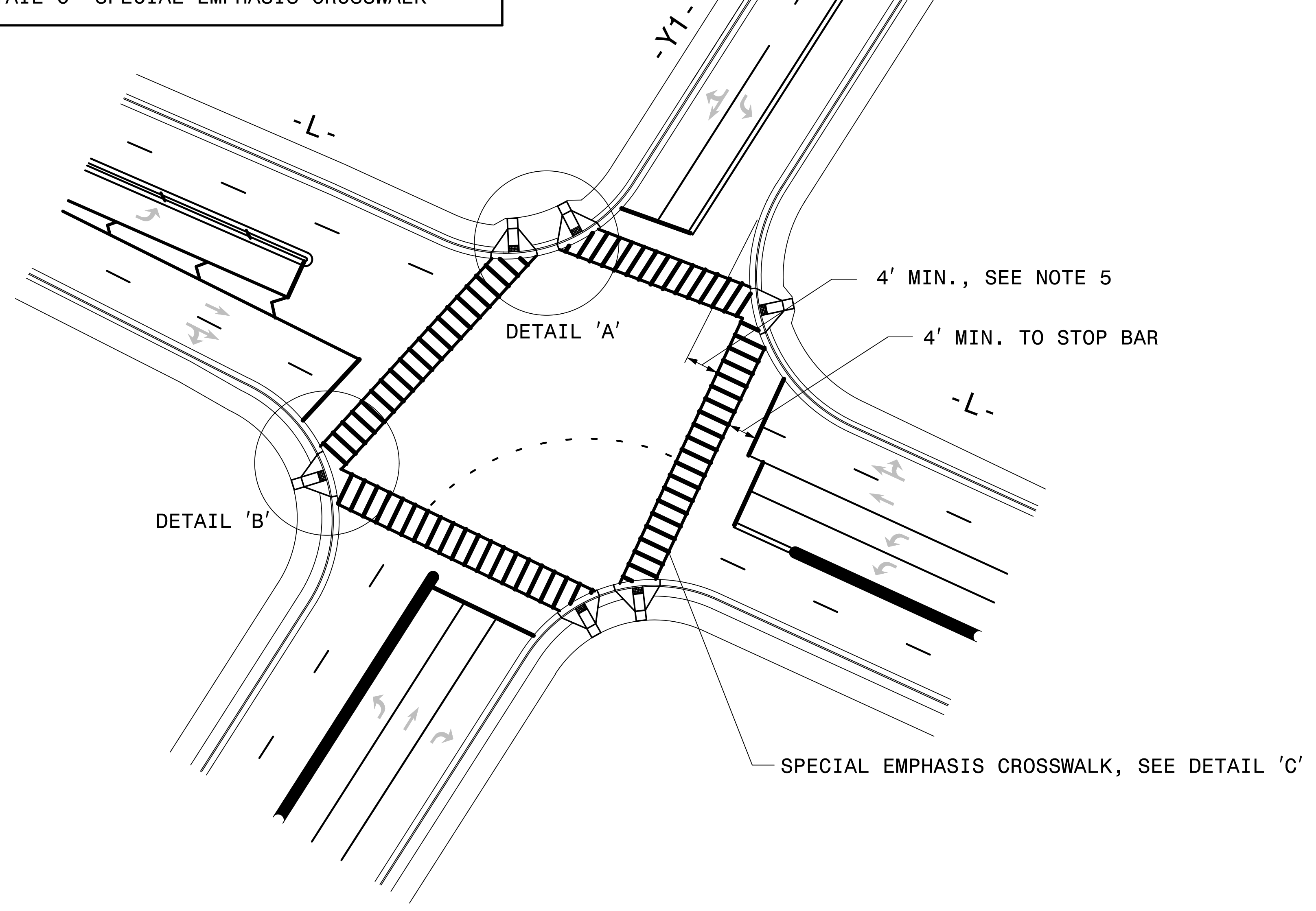

DETAIL 'A'- DUAL CURB RAMPS

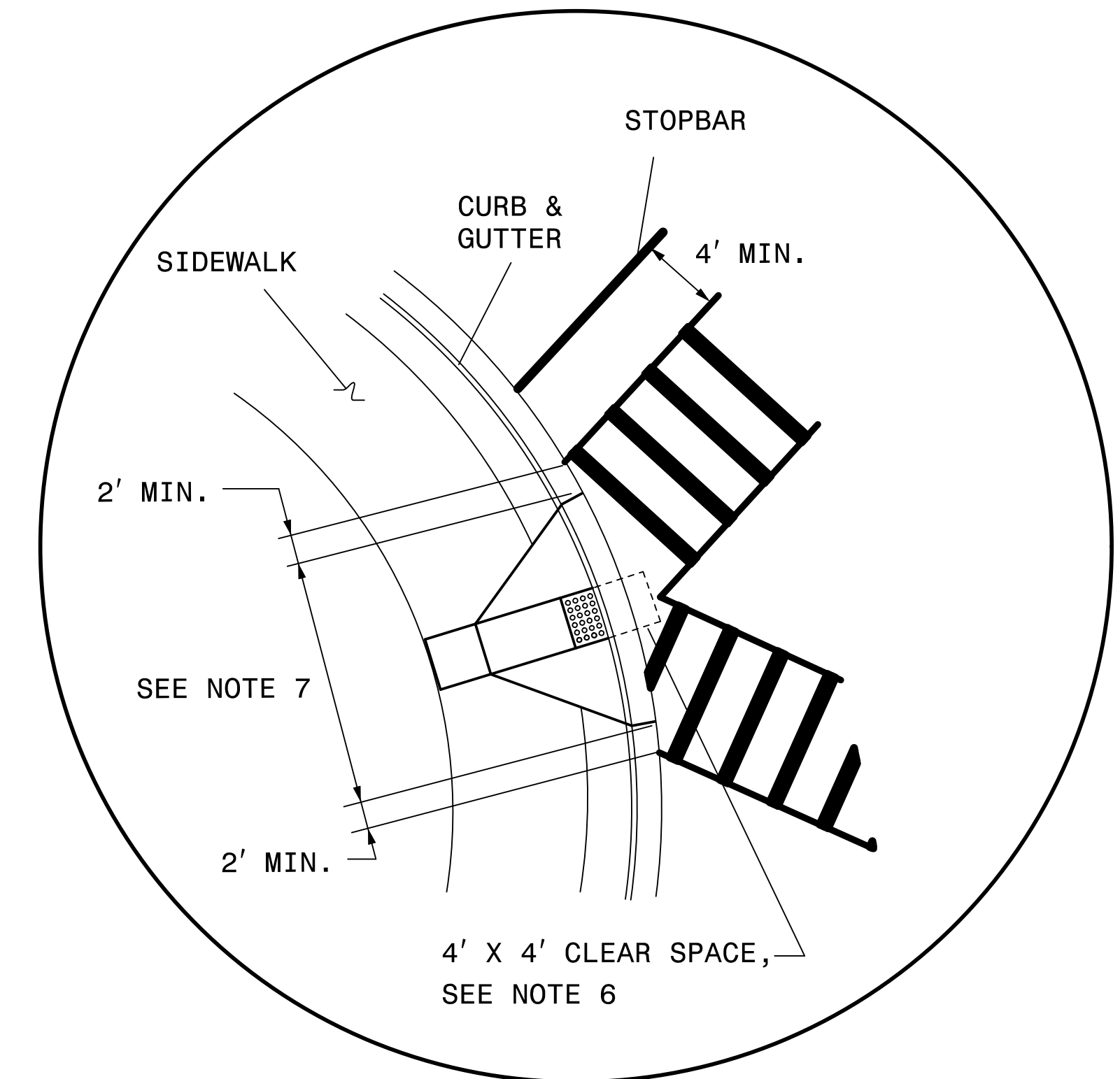

DETAIL 'B'- SINGLE DIAGONAL CURB RAMP

NOTES:

1. USE THE DETAILS ABOVE AND THE FOLLOWING NOTES FOR GUIDANCE IN PLACING CROSSWALK MARKINGS. REFER TO NCDOT ROADWAY STANDARD DRAWINGS, MUTCD AND ADA STANDARDS FOR ADDITIONAL GUIDANCE.
2. THE LOCATION AND TYPE OF CROSSWALK MARKINGS SHOWN ON THE ABOVE DETAILS ARE FOR REFERENCE ONLY. LOCATE CROSSWALK MARKINGS AS SHOWN ON THE PROJECT DETAIL SHEETS OR AS DIRECTED BY THE ENGINEER. THE CROSSWALK MARKING TYPE, SPECIAL EMPHASIS, SHALL BE INSTALLED AS SPECIFIED ON THE PROJECT DETAIL SHEETS OR AS DIRECTED BY THE ENGINEER.
3. THE SPECIAL EMPHASIS CROSSWALK IS TWO WHITE 12" TRANSVERSE LINES WITH A 10' GAP BETWEEN THE LINES AND WHITE 24" WIDE LONGITUDINAL LINES WITH 60" MAXIMUM GAPS BETWEEN LINES, SEE DETAIL 'C'.
4. STOP BARS SHOULD BE PLACED A MINIMUM OF 4' IN ADVANCE OF NEAREST CROSSWALK LINE.
5. SET BACK DISTANCE FROM INSIDE CROSSWALK MARKING TO NEAREST EDGE OF TRAVEL IS 4' MIN.
6. BEYOND THE BOTTOM GRADE BREAK, A CLEAR SPACE OF 4' X 4' MINIMUM SHALL BE PROVIDED WITHIN THE MARKINGS.
7. SINGLE DIAGONAL CURB RAMPS WITH FLARED SIDES SHALL HAVE A SEGMENT OF CURB 2 FEET LONG MINIMUM LOCATED ON EACH SIDE OF THE CURB RAMP AND WITHIN THE MARKED CROSSING, SEE DETAIL 'B'.
8. CURB RAMPS SHALL BE CONSTRUCTED IN ACCORDANCE TO THE LATEST NCDOT ROADWAY STANDARD DRAWINGS.

7/5/2017
P:\PMP\U4751_PMP_02.dgn
HNTB

HNTB
HNTB NORTH CAROLINA, P.C.
343 E. SIX FORKS ROAD, SUITE 200
RALEIGH, NORTH CAROLINA 27609
NC LICENSE NO: C-1554
(919) 546-8997

CROSSWALK PAVEMENT MARKING GUIDANCE DETAIL

TIP NO. U-4751	SHEET NO. PMP-2A
APPROVED: <i>Andrew D. Klinowski</i> <small>E-3078FB4586E44B</small>	
DATE: 7/5/2017	
	
DOCUMENT NOT CONSIDERED FINAL UNLESS ALL SIGNATURES COMPLETED	

STATE OF NORTH CAROLINA
 DEPT. OF TRANSPORTATION
 DIVISION OF HIGHWAYS
 RALEIGH, N.C.

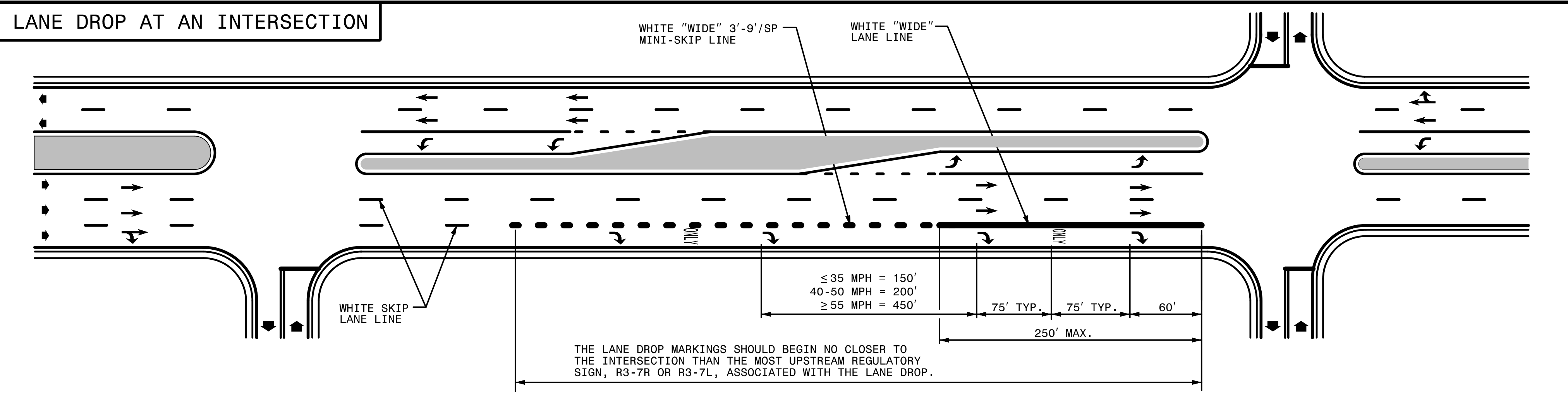

STATE OF NORTH CAROLINA
 DEPT. OF TRANSPORTATION
 DIVISION OF HIGHWAYS
 RALEIGH, N.C.

ENGLISH DETAIL DRAWING FOR
PAVEMENT MARKINGS
 LANE DROPS

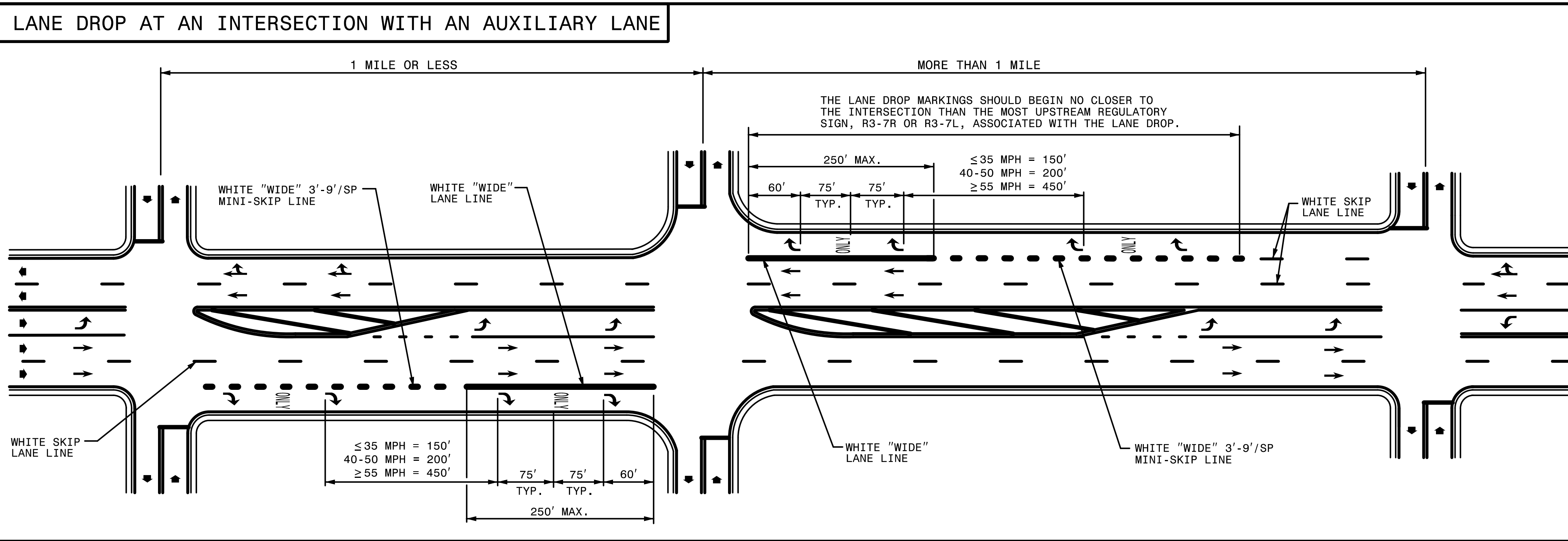

ENGLISH DETAIL DRAWING FOR
PAVEMENT MARKINGS
 LANE DROPS

- GENERAL NOTES:
- USE THE GUIDANCE SHOWN ON THE ABOVE DETAILS IN CONJUNCTION WITH INTERSECTION GUIDANCE SHOWN ON ROADWAY STANDARD DRAWING 1205.04.
 - LANE LINES INDICATED AS "WIDE" SHALL BE AT LEAST TWICE THE WIDTH OF THE NORMAL LINE.

LEGEND	
W = WIDTH OF TRAVEL LANE	ONLY PAVEMENT MARKING SYMBOLS & CHARACTERS
➔ DIRECTION OF TRAFFIC FLOW	

SHEET 1 OF 3
1205D06

SHEET 1 OF 3
1205D06

TIP NO. U-4751	SHEET NO. PMP-3
APPROVED: <i>Andrew D. Klinck</i> E3078F84586E44B	
DATE: 7/5/2017	
	
DOCUMENT NOT CONSIDERED FINAL UNLESS ALL SIGNATURES COMPLETED	

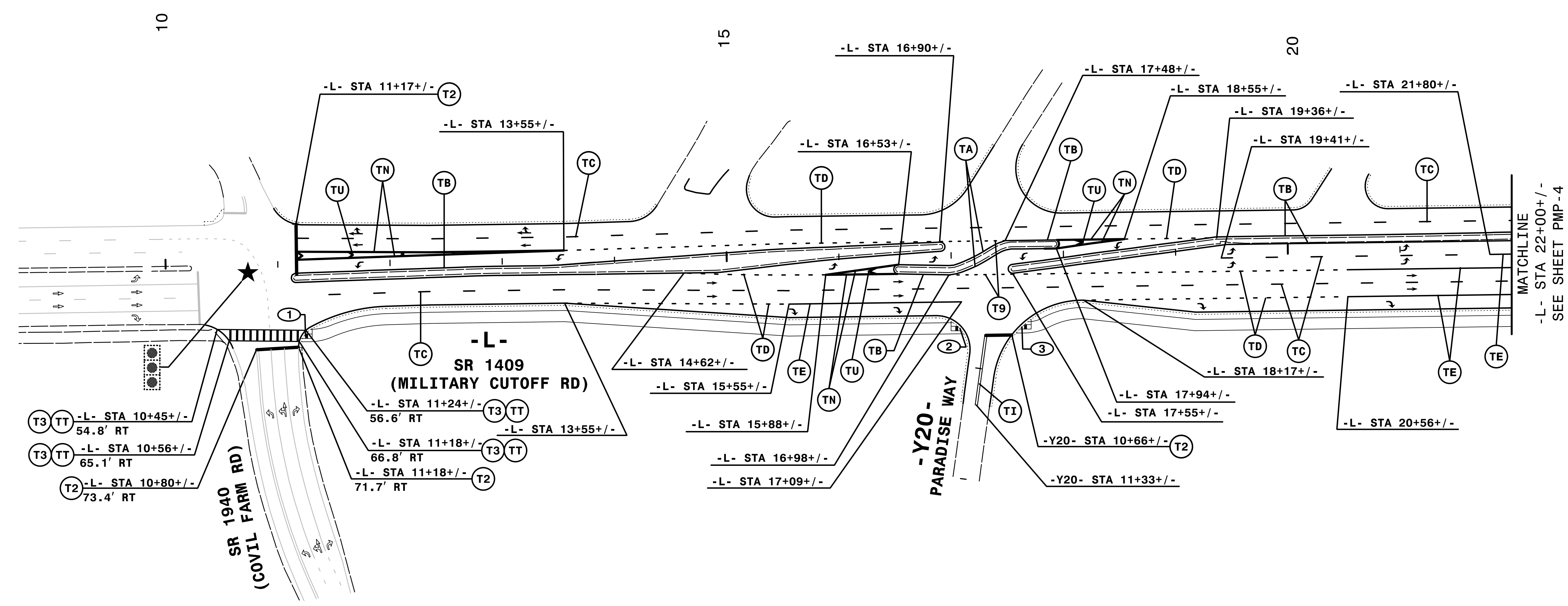

- ① -L- STA 11+22+/- (61.9' RT) (TYPE 1)
- ② -L- STA 17+07+/- (62.7' RT) (TYPE 1)
- ③ -L- STA 17+62+/- (62.0' RT) (TYPE 1)

SEE SHEET PMP-2 FOR CROSSWALK DETAILS

NOTE: ALL LANE WIDTHS ARE 12' UNLESS OTHERWISE SHOWN.

HNTB

HNTB NORTH CAROLINA, P.C.
343 E. Six Forks Road, Suite 200
Raleigh, North Carolina 27609
NC License No: C-1554
(919) 546-8997

PAVEMENT MARKING DETAIL

7/5/2017
P:\PMP\U4751_PMP_03.dgn
HNTB

TIP NO. U-4751	SHEET NO. PMP-4
APPROVED: <i>Andrew D. Klinkosiek</i> E3078F84586E44B	
DATE: 7/5/2017	
	
DOCUMENT NOT CONSIDERED FINAL UNLESS ALL SIGNATURES COMPLETED	

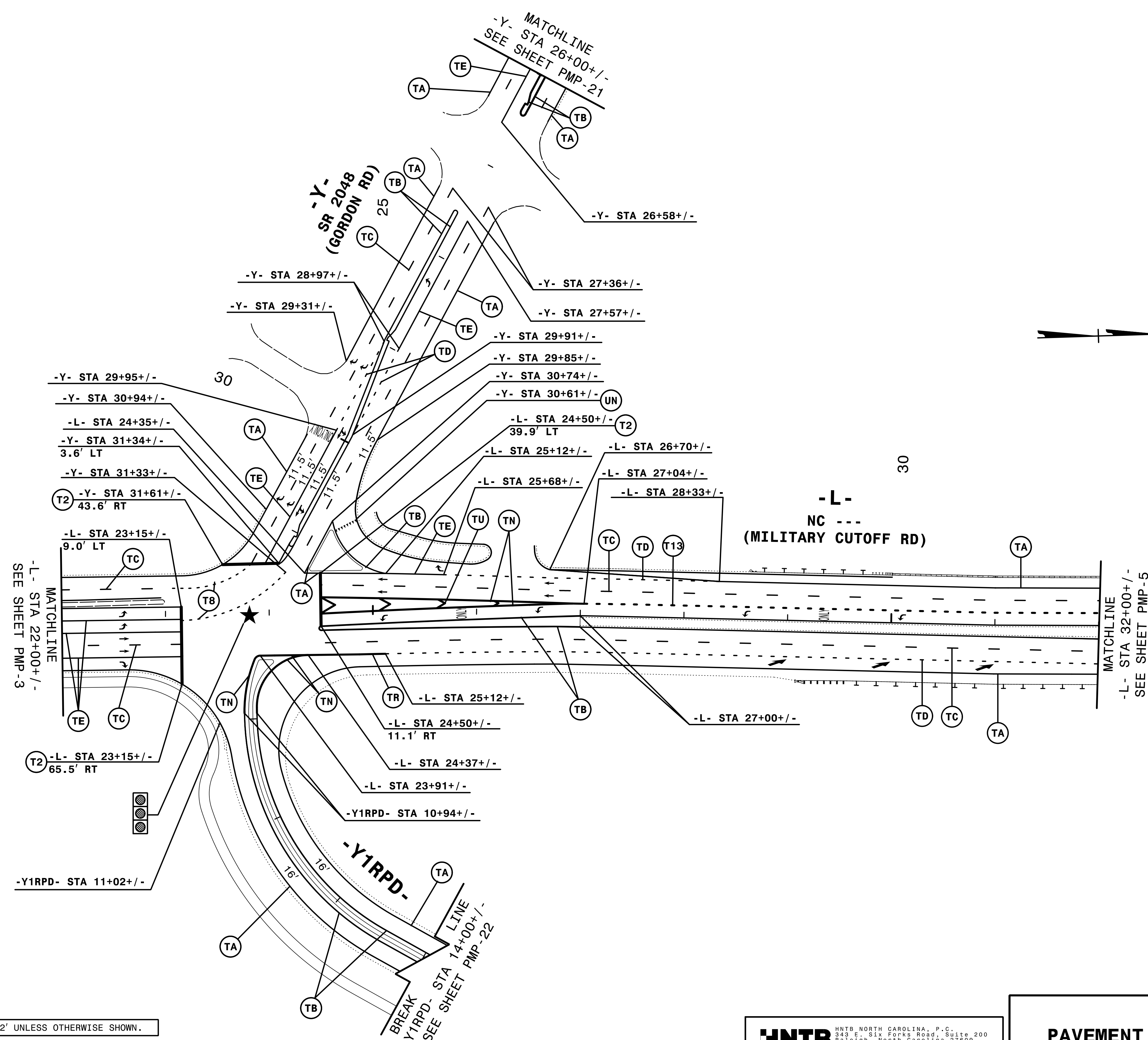

7/5/2017
PMP-U4751_PMP_04.dgn
HNTB

NOTE: ALL LANE WIDTHS ARE 12' UNLESS OTHERWISE SHOWN.

HNTB
 HNTB NORTH CAROLINA, P.C.
 343 E. Six Forks Road, Suite 200
 Raleigh, North Carolina 27609
 NC License No: C-1554
 (919) 546-8997

PAVEMENT MARKING DETAIL

TIP NO. U-4751	SHEET NO. PMP-5
APPROVED: <i>Andrew D. Klinkosiek</i> E3078F84586E44B	
DATE: 7/5/2017	
	
DOCUMENT NOT CONSIDERED FINAL UNLESS ALL SIGNATURES COMPLETED	

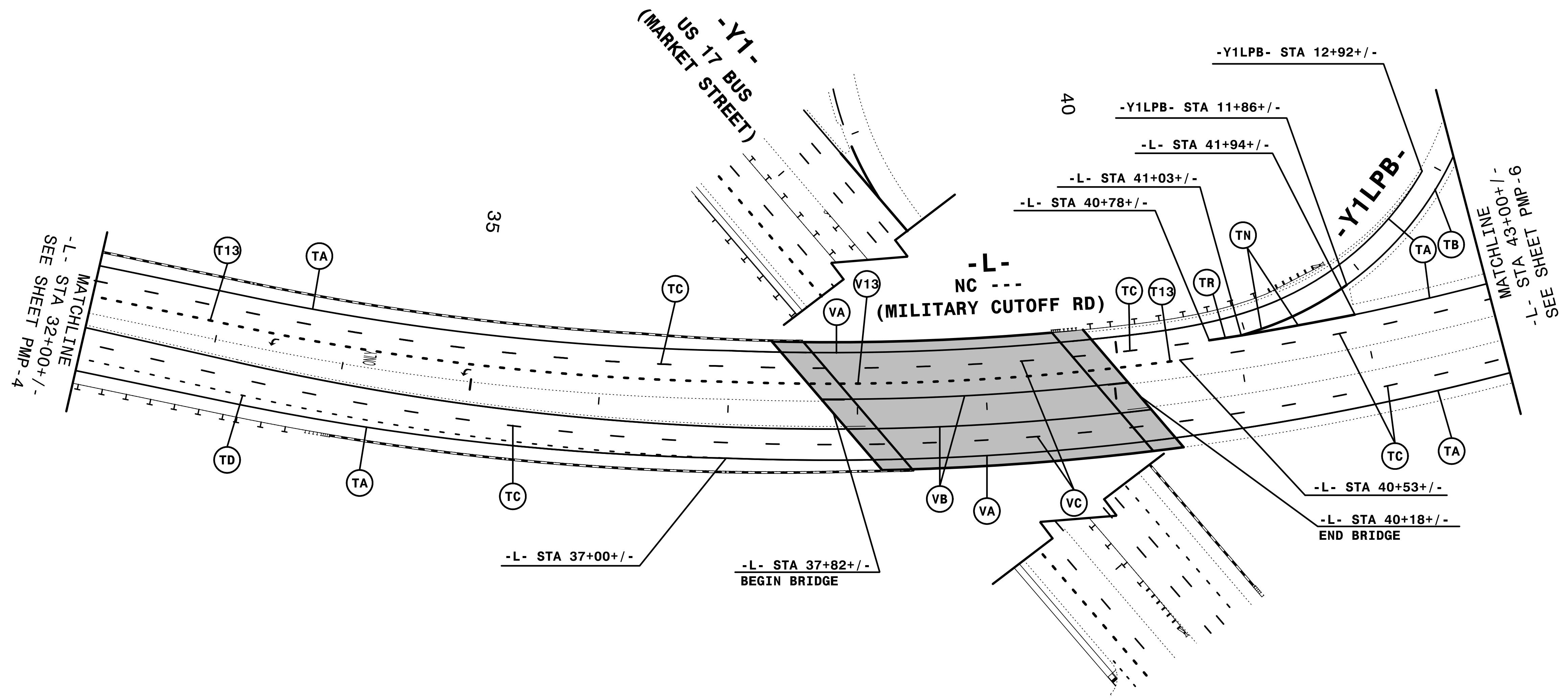

NOTE: ALL LANE WIDTHS ARE 12' UNLESS OTHERWISE SHOWN.

7/5/2017
P:\PMP\U4751_PMP_05.dgn
HNTB

HNTB
 HNTB NORTH CAROLINA, P.C.
 343 E. SIX FORKS ROAD, SUITE 200
 RALEIGH, NORTH CAROLINA 27609
 NC LICENSE NO: C-1554
 (919) 546-8997

PAVEMENT MARKING DETAIL

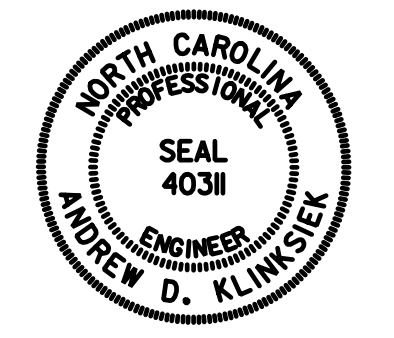
TIP NO. U-4751	SHEET NO. PMP-6
APPROVED: <i>Andrew D. Klinck</i> E3078FB4596E44B	
DATE: 7/5/2017	
	
DOCUMENT NOT CONSIDERED FINAL UNLESS ALL SIGNATURES COMPLETED	

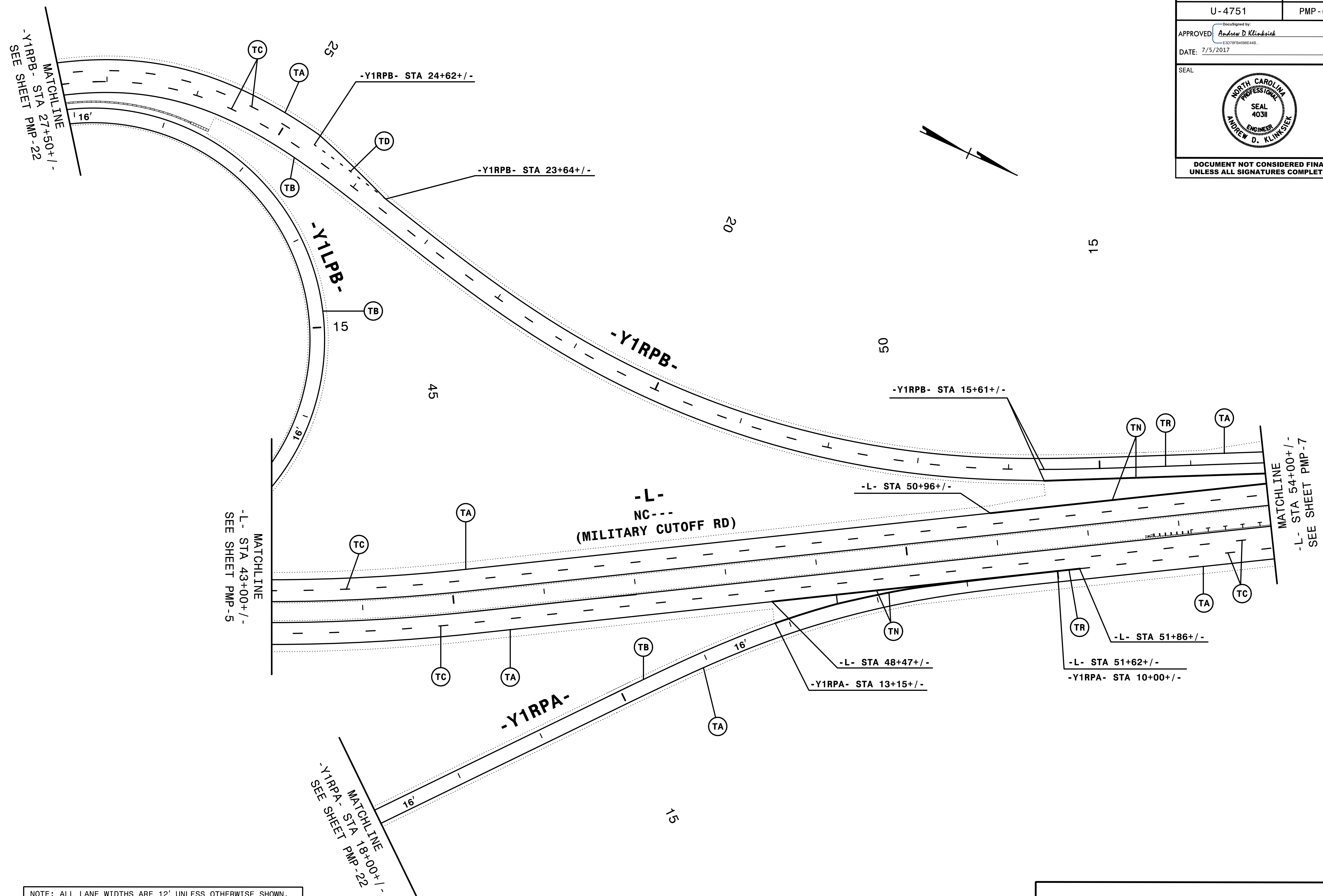

NOTE: ALL LANE WIDTHS ARE 12' UNLESS OTHERWISE SHOWN.

7/5/2017
P:\PMP\U4751_PMP_06.dgn
HNTB

HNTB
 HNTB NORTH CAROLINA, P.C.
 343 E. Six Forks Road, Suite 200
 Raleigh, North Carolina 27609
 NC License No: C-1554
 (919) 546-8997

PAVEMENT MARKING DETAIL

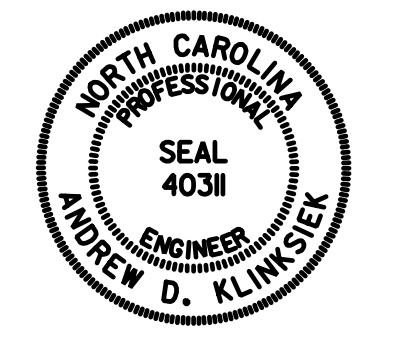
TIP NO. U-4751	SHEET NO. PMP-7
APPROVED: <i>Andrew D. Klinck</i> E3078F84596E44B	
DATE: 7/5/2017	
	
DOCUMENT NOT CONSIDERED FINAL UNLESS ALL SIGNATURES COMPLETED	

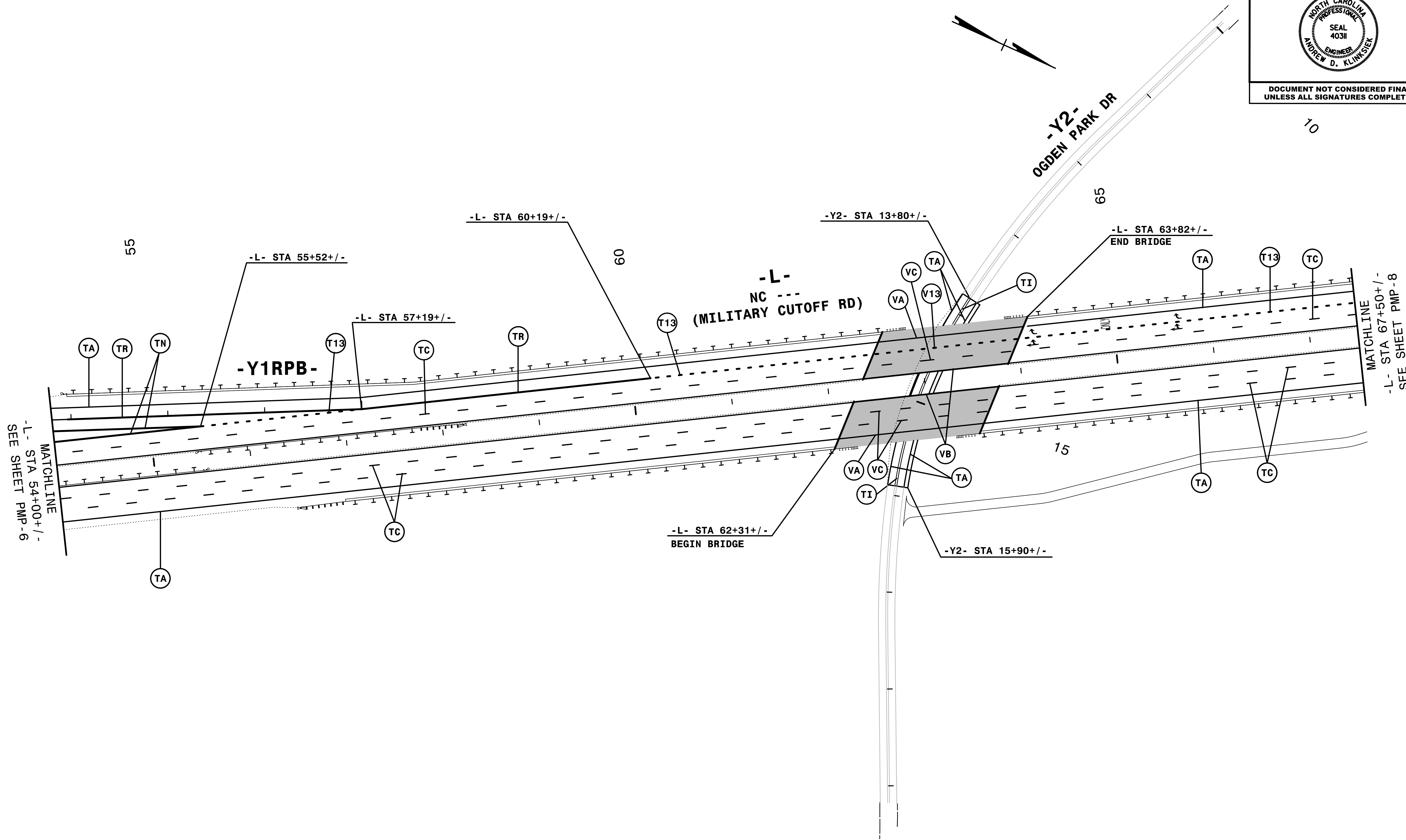

NOTE: ALL LANE WIDTHS ARE 12' UNLESS OTHERWISE SHOWN.

HNTB
 HNTB NORTH CAROLINA, P.C.
 343 E. Six Forks Road, Suite 200
 Raleigh, North Carolina 27609
 NC License No: C-1554
 (919) 546-8997

PAVEMENT MARKING DETAIL

7/5/2017
P:\PMP\U4751_PMP_07.dgn
HNTB

TIP NO. U-4751	SHEET NO. PMP-8
APPROVED <i>Andrew D. Klinkosiek</i> E3078F84586E44B	
DATE: 7/5/2017	
	
DOCUMENT NOT CONSIDERED FINAL UNLESS ALL SIGNATURES COMPLETED	

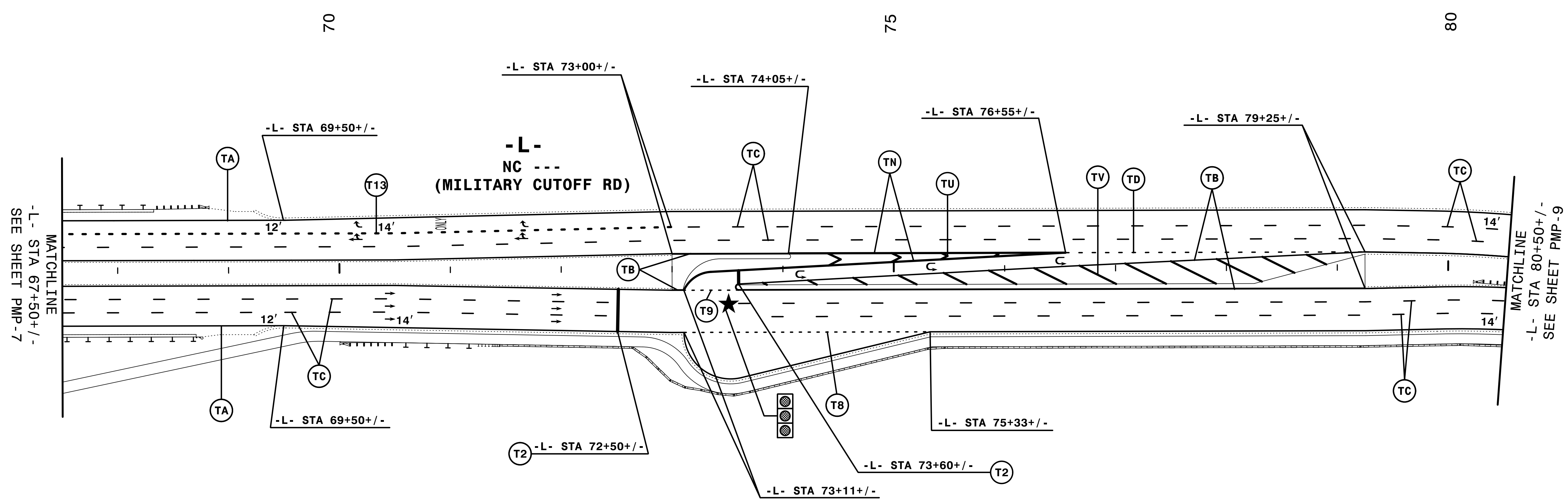

NOTE: ALL LANE WIDTHS ARE 12' UNLESS OTHERWISE SHOWN.

7/5/2017
P:\PMP\U4751_PMP_08.dgn
HNTB

HNTB HNTB NORTH CAROLINA, P.C.
343 E. SIX FORKS ROAD, SUITE 200
RALEIGH, NORTH CAROLINA 27609
NC LICENSE NO: C-1554
(919) 546-6997

PAVEMENT MARKING DETAIL

TIP NO. U-4751	SHEET NO. PMP-9
APPROVED: <i>Andrew D. Klinksieck</i> E3078FB4586E44B	
DATE: 7/5/2017	
	
DOCUMENT NOT CONSIDERED FINAL UNLESS ALL SIGNATURES COMPLETED	

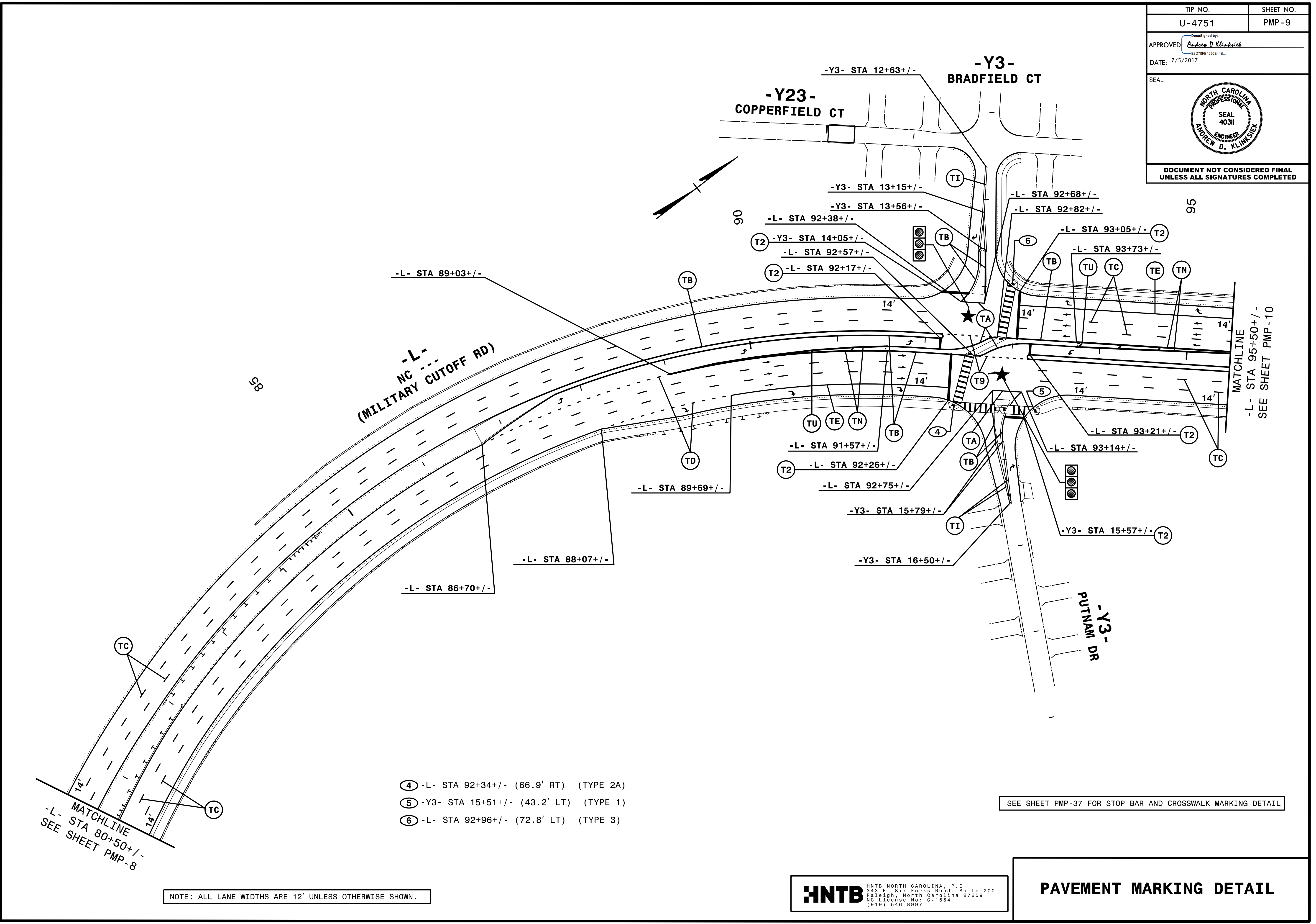

- ④ -L- STA 92+34+/- (66.9' RT) (TYPE 2A)
- ⑤ -Y3- STA 15+51+/- (43.2' LT) (TYPE 1)
- ⑥ -L- STA 92+96+/- (72.8' LT) (TYPE 3)

SEE SHEET PMP-37 FOR STOP BAR AND CROSSWALK MARKING DETAIL

NOTE: ALL LANE WIDTHS ARE 12' UNLESS OTHERWISE SHOWN.

HNTB
 HNTB NORTH CAROLINA, P.C.
 343 E. SIX FORKS ROAD, SUITE 200
 RALEIGH, NORTH CAROLINA 27609
 NC LICENSE NO: C-1554
 (919) 546-8997

PAVEMENT MARKING DETAIL

7/5/2017
PMP-U4751_PMP_09.dgn
HNTB

TIP NO. U-4751	SHEET NO. PMP-10
APPROVED: <i>Andrew D. Klinskiak</i> E3078FB4586E44B	
DATE: 7/5/2017	
	
DOCUMENT NOT CONSIDERED FINAL UNLESS ALL SIGNATURES COMPLETED	

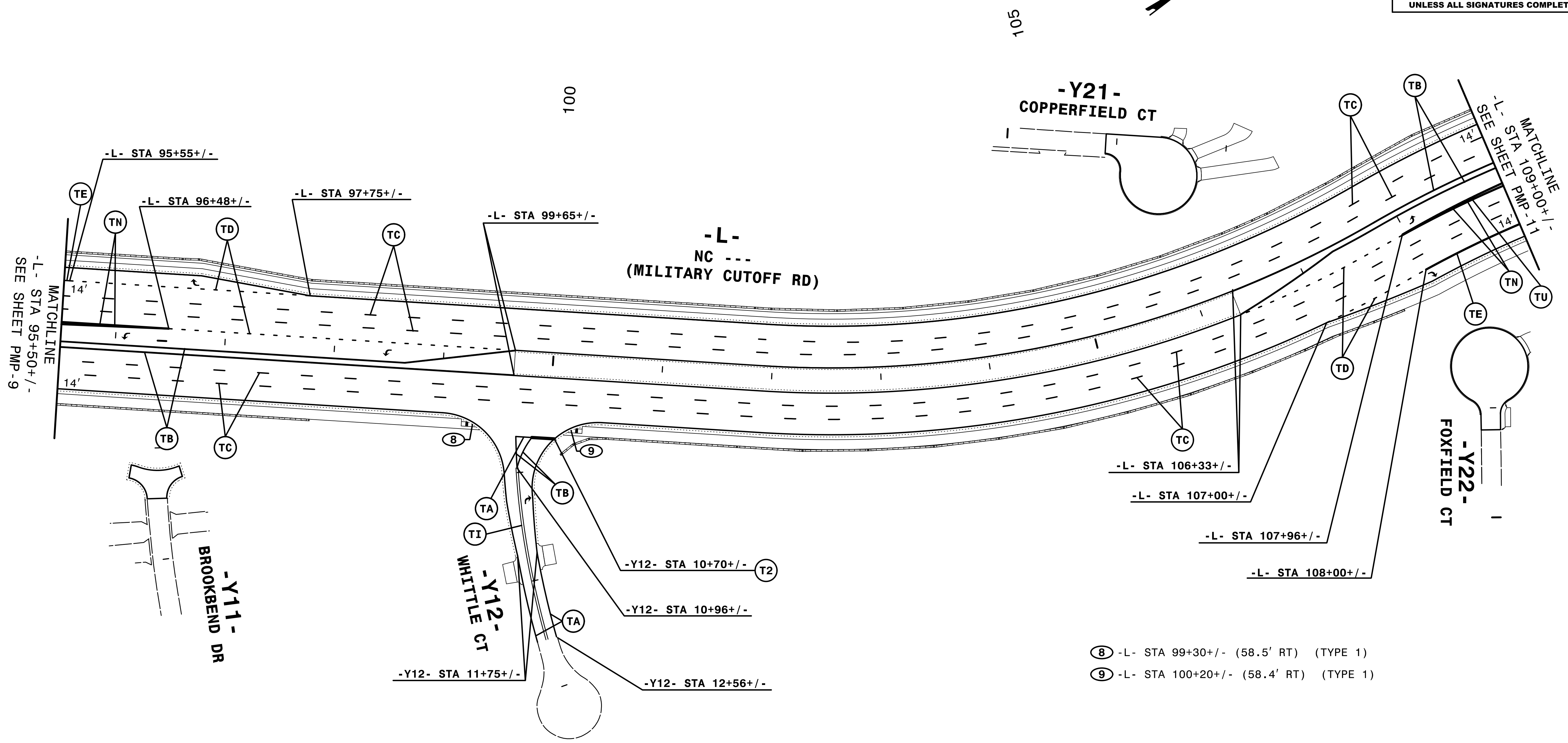

- ⑧ -L- STA 99+30+/- (58.5' RT) (TYPE 1)
- ⑨ -L- STA 100+20+/- (58.4' RT) (TYPE 1)

NOTE: ALL LANE WIDTHS ARE 12' UNLESS OTHERWISE SHOWN.

HNTB
 HNTB NORTH CAROLINA, P.C.
 343 E. Six Forks Road, Suite 200
 Raleigh, North Carolina 27609
 NC License No: C-1554
 (919) 546-8997

PAVEMENT MARKING DETAIL

7/5/2017
 P:\PMP\U4751_PMP_10.dgn
 HNTB

TIP NO. U-4751	SHEET NO. PMP-11
APPROVED: <i>Andrew D. Klinski</i> E3078F84586E44B	
DATE: 7/5/2017	
	
DOCUMENT NOT CONSIDERED FINAL UNLESS ALL SIGNATURES COMPLETED	

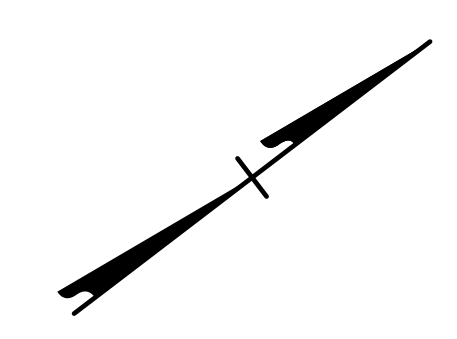
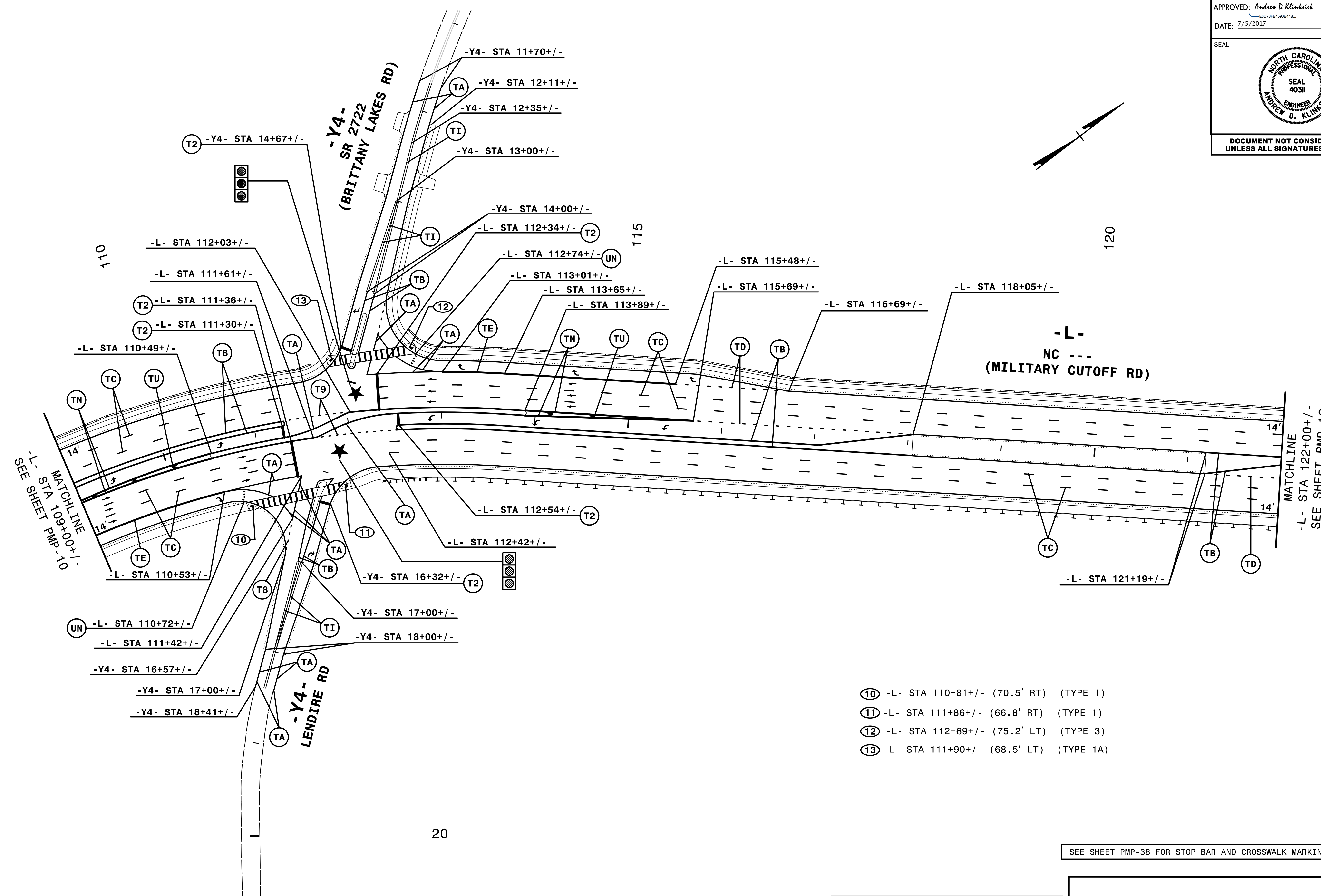

NOTE: ALL LANE WIDTHS ARE 12' UNLESS OTHERWISE SHOWN.

- ⑩ -L- STA 110+81+/- (70.5' RT) (TYPE 1)
- ⑪ -L- STA 111+86+/- (66.8' RT) (TYPE 1)
- ⑫ -L- STA 112+69+/- (75.2' LT) (TYPE 3)
- ⑬ -L- STA 111+90+/- (68.5' LT) (TYPE 1A)

SEE SHEET PMP-38 FOR STOP BAR AND CROSSWALK MARKING DETAIL

HNTB
 HNTB NORTH CAROLINA, P.C.
 343 E. Six Forks Road, Suite 200
 Raleigh, North Carolina 27609
 NC License No: C-1554
 (919) 546-8997

PAVEMENT MARKING DETAIL

7/5/2017
 P:\PMP\U4751_PMP_11.dgn
 HNTB

TIP NO. U-4751	SHEET NO. PMP-12
APPROVED: <i>Andrew D. Klinsky</i> E3078FB4586E44B	
DATE: 7/5/2017	
	
DOCUMENT NOT CONSIDERED FINAL UNLESS ALL SIGNATURES COMPLETED	

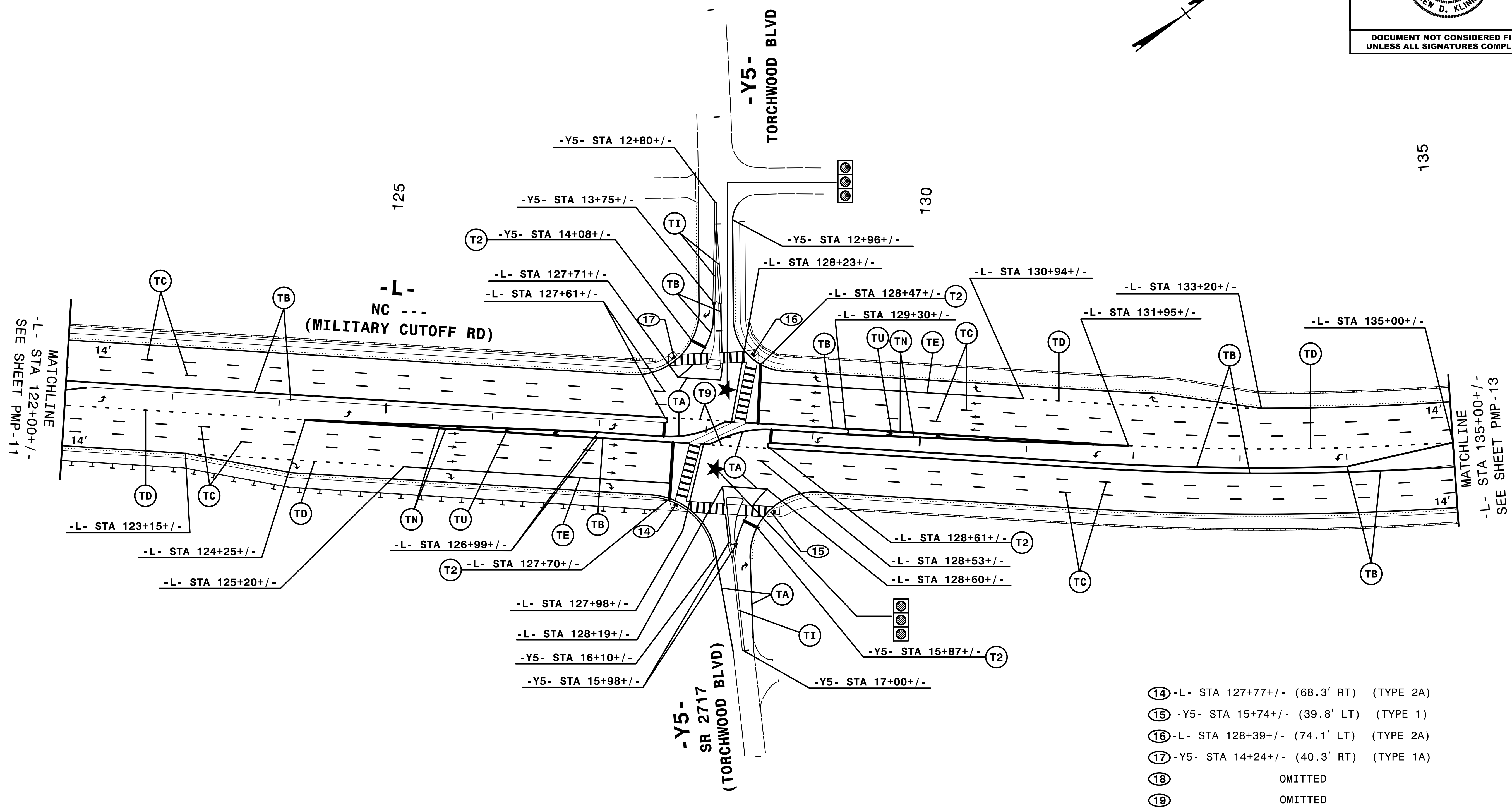

- ⑭ -L- STA 127+77+/- (68.3' RT) (TYPE 2A)
- ⑮ -Y5- STA 15+74+/- (39.8' LT) (TYPE 1)
- ⑯ -L- STA 128+39+/- (74.1' LT) (TYPE 2A)
- ⑰ -Y5- STA 14+24+/- (40.3' RT) (TYPE 1A)
- ⑱ OMITTED
- ⑲ OMITTED

SEE SHEET PMP-38 FOR STOP BAR AND CROSSWALK MARKING DETAIL

NOTE: ALL LANE WIDTHS ARE 12' UNLESS OTHERWISE SHOWN.

HNTB
 HNTB NORTH CAROLINA, P.C.
 343 E. Six Forks Road, Suite 200
 Raleigh, North Carolina 27609
 NC License No: C-1554
 (919) 546-8997

PAVEMENT MARKING DETAIL

7/5/2017
 P:\PMP\U4751_PMP_12.dgn
 HNTB

TIP NO. U-4751	SHEET NO. PMP-13
APPROVED: <i>Andrew D. Klinck</i> <small>E3078FB4586E44B</small>	
DATE: 7/5/2017	
	
DOCUMENT NOT CONSIDERED FINAL UNLESS ALL SIGNATURES COMPLETED	

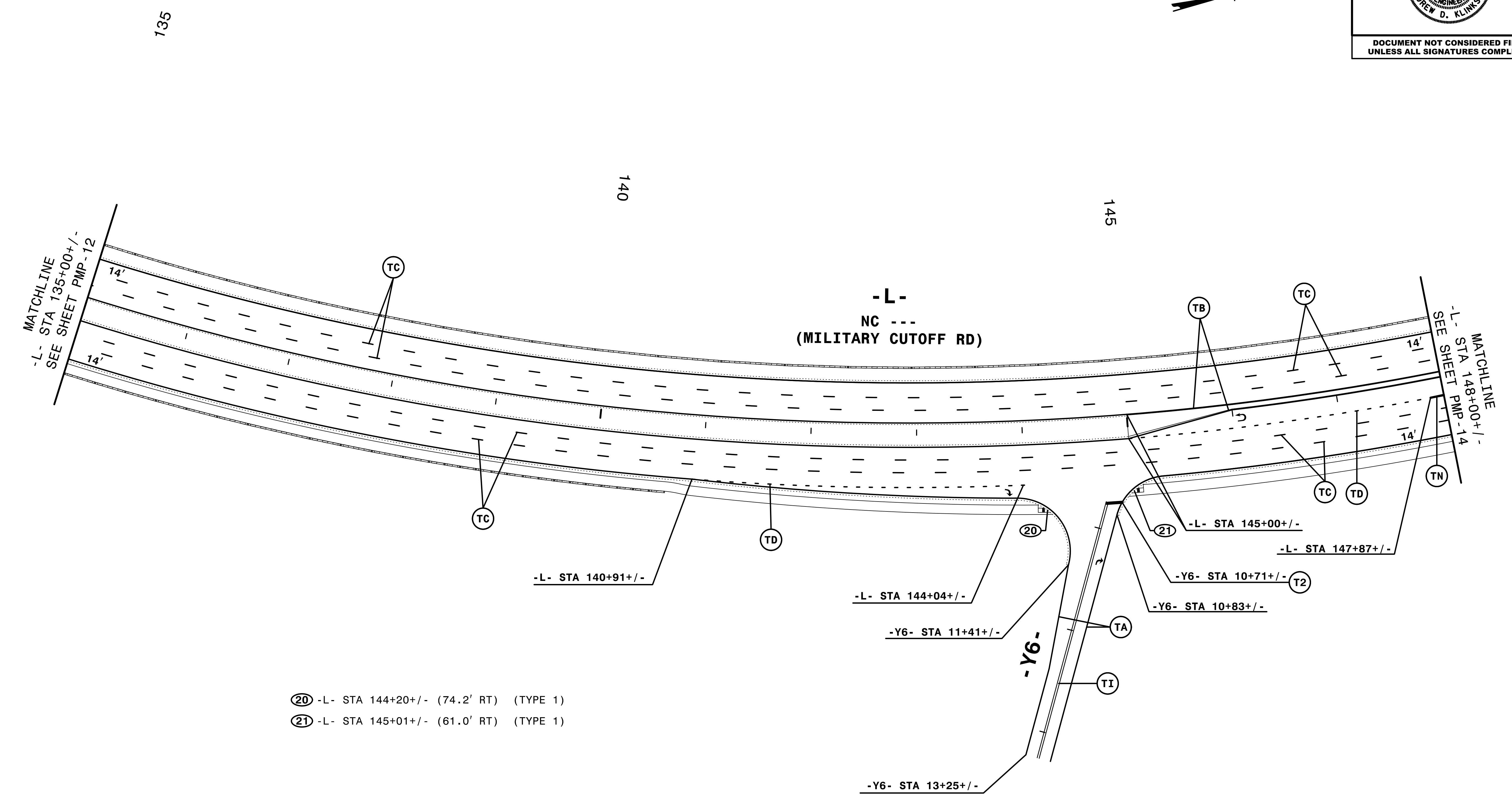

- (20) -L- STA 144+20+/- (74.2' RT) (TYPE 1)
- (21) -L- STA 145+01+/- (61.0' RT) (TYPE 1)

NOTE: ALL LANE WIDTHS ARE 12' UNLESS OTHERWISE SHOWN.

HNTB
 HNTB NORTH CAROLINA, P.C.
 343 E. SIX FORKS ROAD, SUITE 200
 RALEIGH, NORTH CAROLINA 27609
 NC License No: C-1554
 (919) 546-8997

PAVEMENT MARKING DETAIL

7/5/2017
 P:\PMP\U4751_PMP_13.dgn
 HNTB

TIP NO. U-4751	SHEET NO. PMP-14
APPROVED: <i>Andrew D. Klinksiek</i> E3078F84586E44B	
DATE: 7/5/2017	
SEAL 	
DOCUMENT NOT CONSIDERED FINAL UNLESS ALL SIGNATURES COMPLETED	

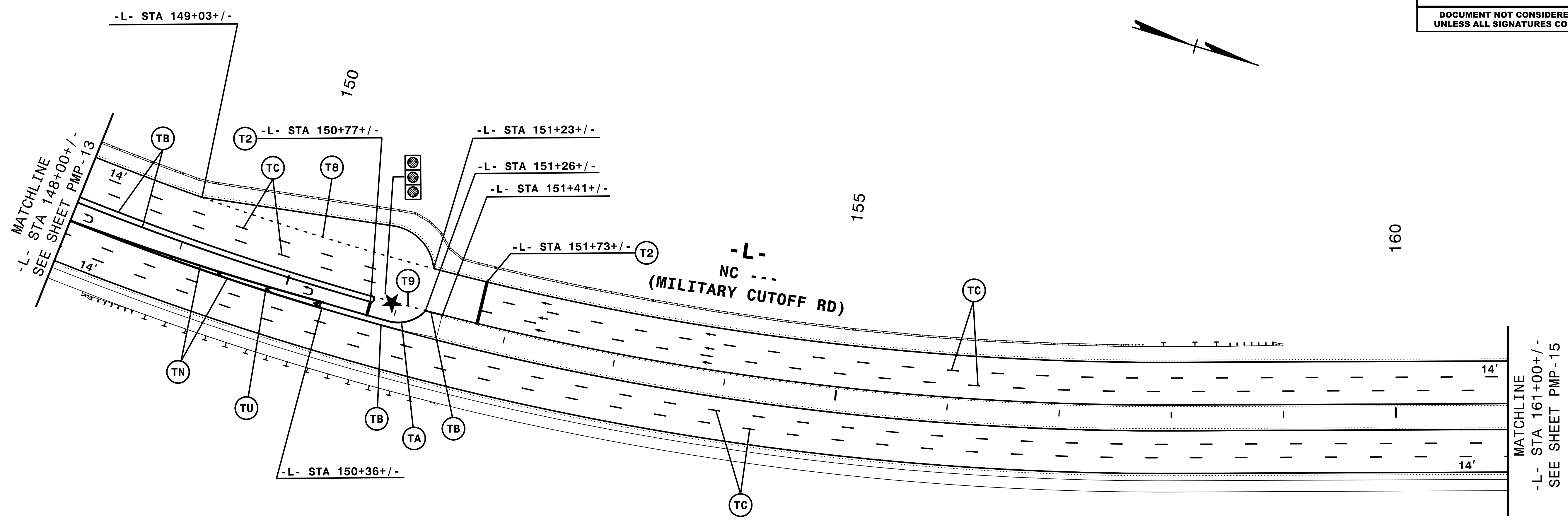

NOTE: ALL LANE WIDTHS ARE 12' UNLESS OTHERWISE SHOWN.

7/5/2017
P:\PMP\U4751_PMP_14.dgn
HNTB

HNTB HNTB NORTH CAROLINA, P.C.
343 E. SIX FORKS ROAD, SUITE 200
RALEIGH, NORTH CAROLINA 27609
NC LICENSE NO: C-1554
(919) 546-8997

PAVEMENT MARKING DETAIL

TIP NO.	SHEET NO.
U-4751	PMP-15
APPROVED: <i>Andrew D. Klinkosiek</i> E3078FB4586E44B	
DATE: 7/5/2017	
	
DOCUMENT NOT CONSIDERED FINAL UNLESS ALL SIGNATURES COMPLETED	

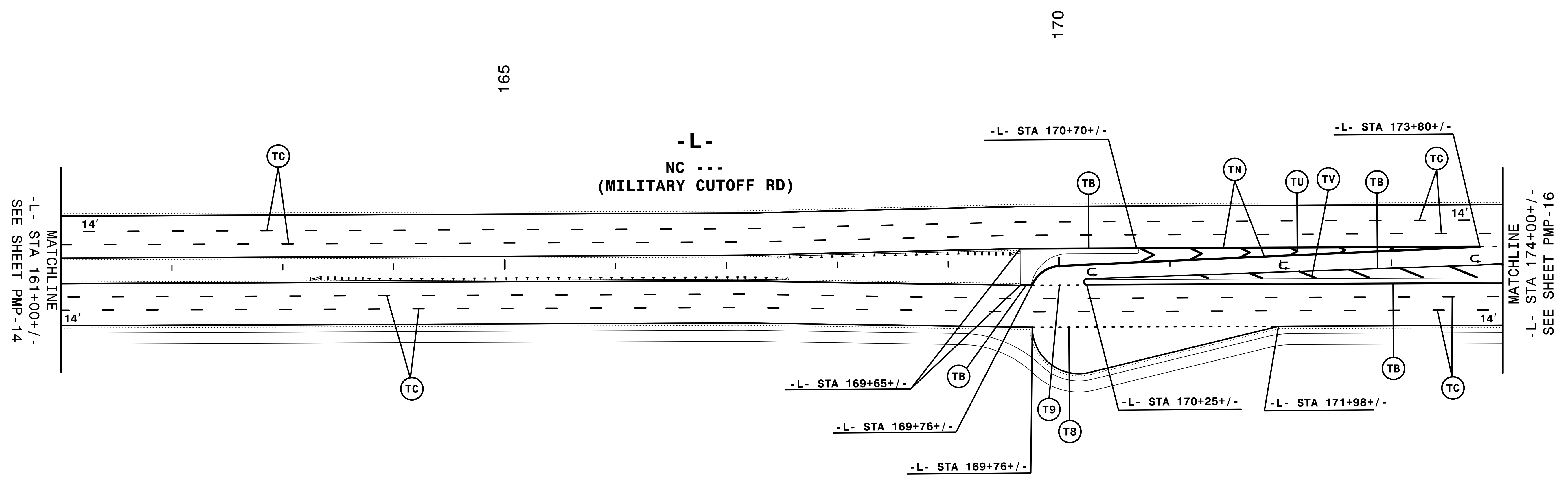

NOTE: ALL LANE WIDTHS ARE 12' UNLESS OTHERWISE SHOWN.

HNTB
 HNTB NORTH CAROLINA, P.C.
 343 E. SIX FORKS ROAD, SUITE 200
 RALEIGH, NORTH CAROLINA 27609
 NC LICENSE NO: C-1554
 (919) 546-8997

PAVEMENT MARKING DETAIL

7/5/2017
P:\PMP\U4751_PMP_15.dgn
HNTB

TIP NO. U-4751	SHEET NO. PMP-16
APPROVED: <i>Andrew D. Klinkosiek</i> E3078F84586E44B	
DATE: 7/5/2017	
	
DOCUMENT NOT CONSIDERED FINAL UNLESS ALL SIGNATURES COMPLETED	

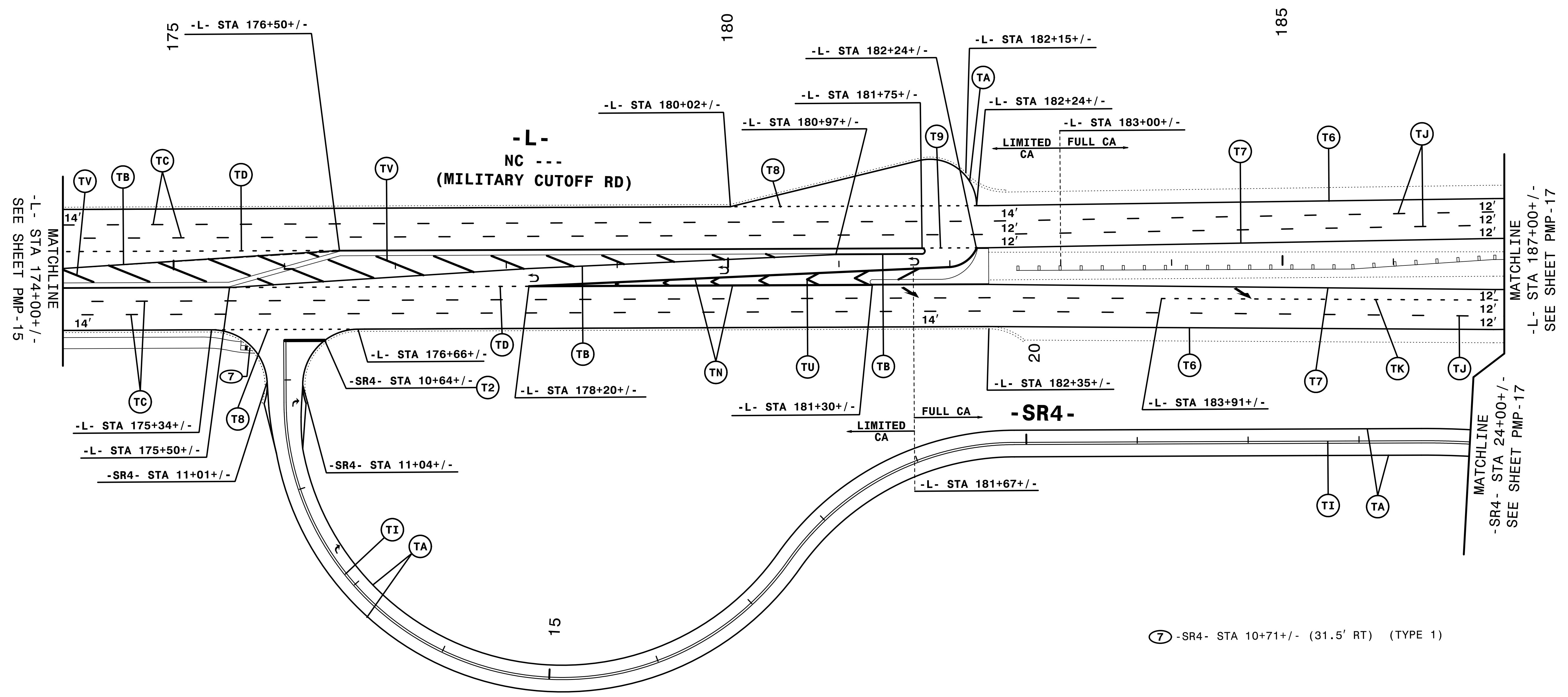
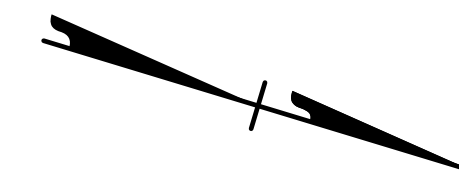

MATCHLINE
-L- STA 174+00+/-
SEE SHEET PMP-15

MATCHLINE
-L- STA 187+00+/-
SEE SHEET PMP-17

NOTE: ALL LANE WIDTHS ARE 12' UNLESS OTHERWISE SHOWN.

7/5/2017
PMP-U4751_PMP_16.dgn
HNTB

HNTB
 HNTB NORTH CAROLINA, P.C.
 343 E. SIX FORKS ROAD, SUITE 200
 RALEIGH, NORTH CAROLINA 27609
 NC LICENSE NO: C-1554
 (919) 546-8997

PAVEMENT MARKING DETAIL

TIP NO.	SHEET NO.
U-4751	PMP-17
APPROVED: <i>Andrew D. Klinskiak</i> E3078FB4586E44B	
DATE: 7/5/2017	
	
DOCUMENT NOT CONSIDERED FINAL UNLESS ALL SIGNATURES COMPLETED	

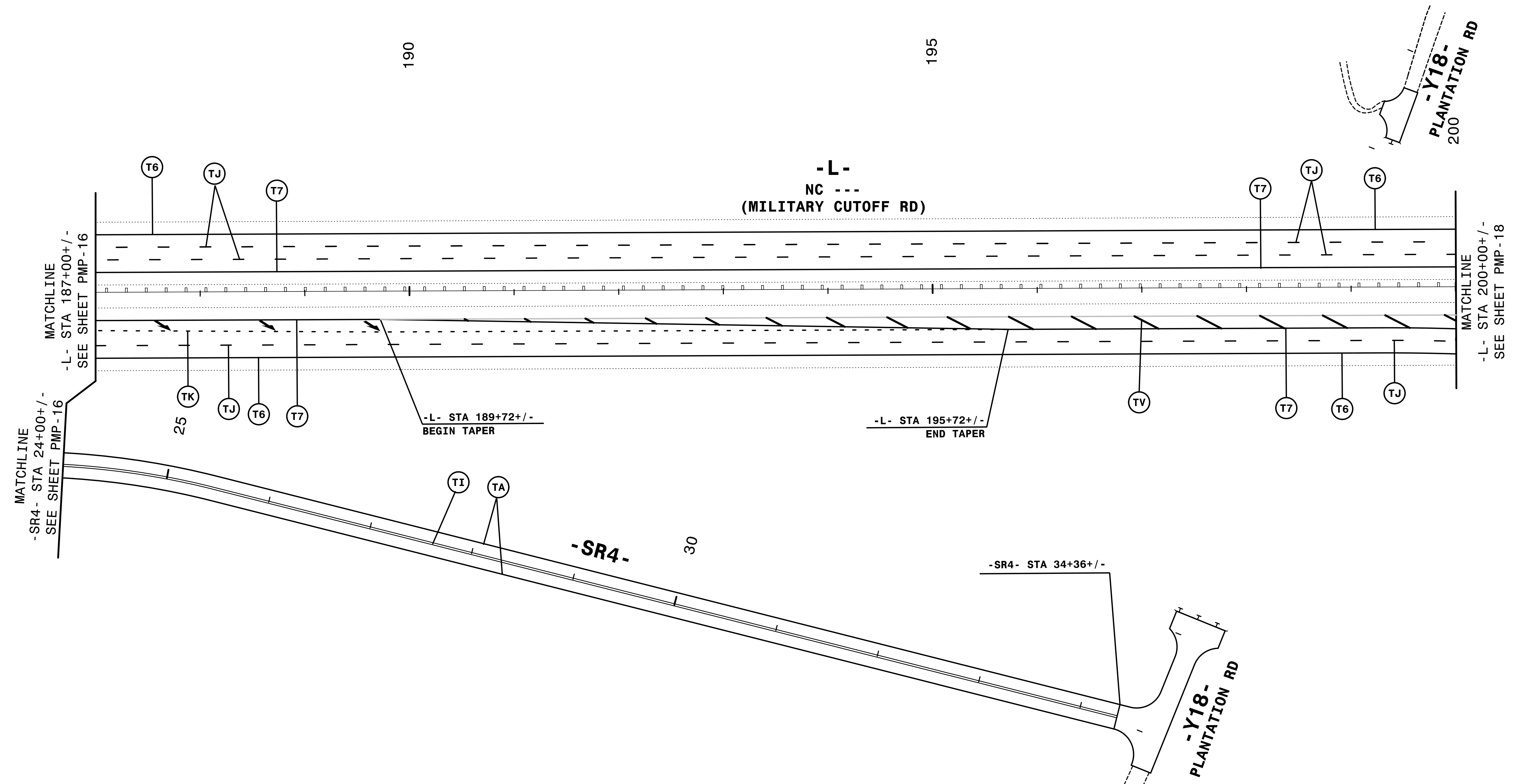

NOTE: ALL LANE WIDTHS ARE 12' UNLESS OTHERWISE SHOWN.

HNTB
 HNTB NORTH CAROLINA, P.C.
 343 E. Six Forks Road, Suite 200
 Raleigh, North Carolina 27609
 NC License No: C-1554
 (919) 546-8997

PAVEMENT MARKING DETAIL

7/5/2017
PMP-U4751_PMP_17.dgn
HNTB

TIP NO. U-4751	SHEET NO. PMP-18
APPROVED: <i>Andrew D. Klinksieck</i> E3078F84586E44B	
DATE: 7/5/2017	
	
DOCUMENT NOT CONSIDERED FINAL UNLESS ALL SIGNATURES COMPLETED	

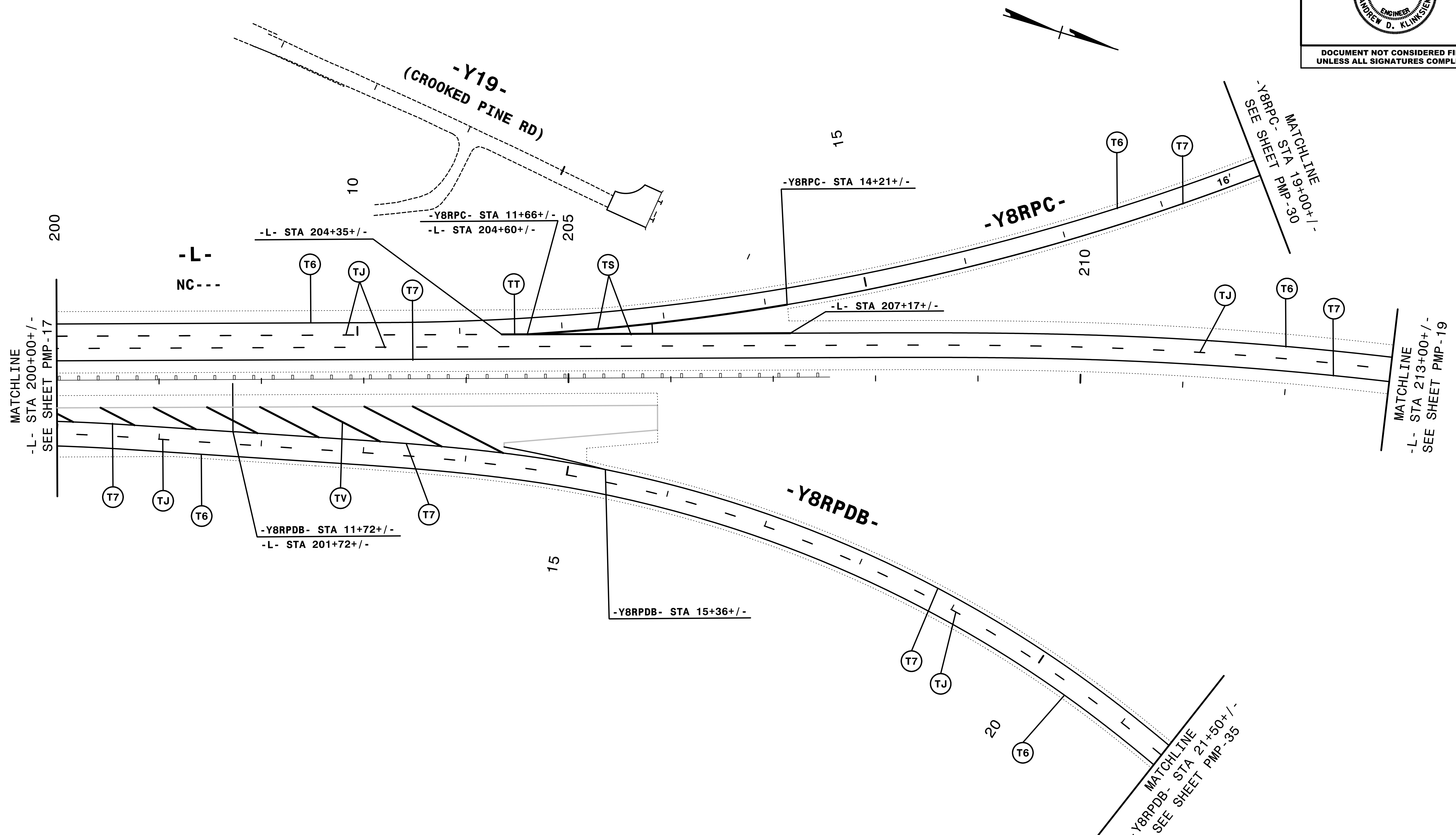

NOTE: ALL LANE WIDTHS ARE 12' UNLESS OTHERWISE SHOWN.

HNTB
 HNTB NORTH CAROLINA, P.C.
 343 E. SIX FORKS ROAD, SUITE 200
 RALEIGH, NORTH CAROLINA 27609
 NC License No: C-1554
 (919) 546-8997

PAVEMENT MARKING DETAIL

7/5/2017
PMP-U4751_PMP_18.dgn
HNTB

TIP NO. U-4751	SHEET NO. PMP-19
APPROVED: <i>Andrew D. Klinck</i> E3078FB4586E44B	
DATE: 7/5/2017	
SEAL	
	
DOCUMENT NOT CONSIDERED FINAL UNLESS ALL SIGNATURES COMPLETED	

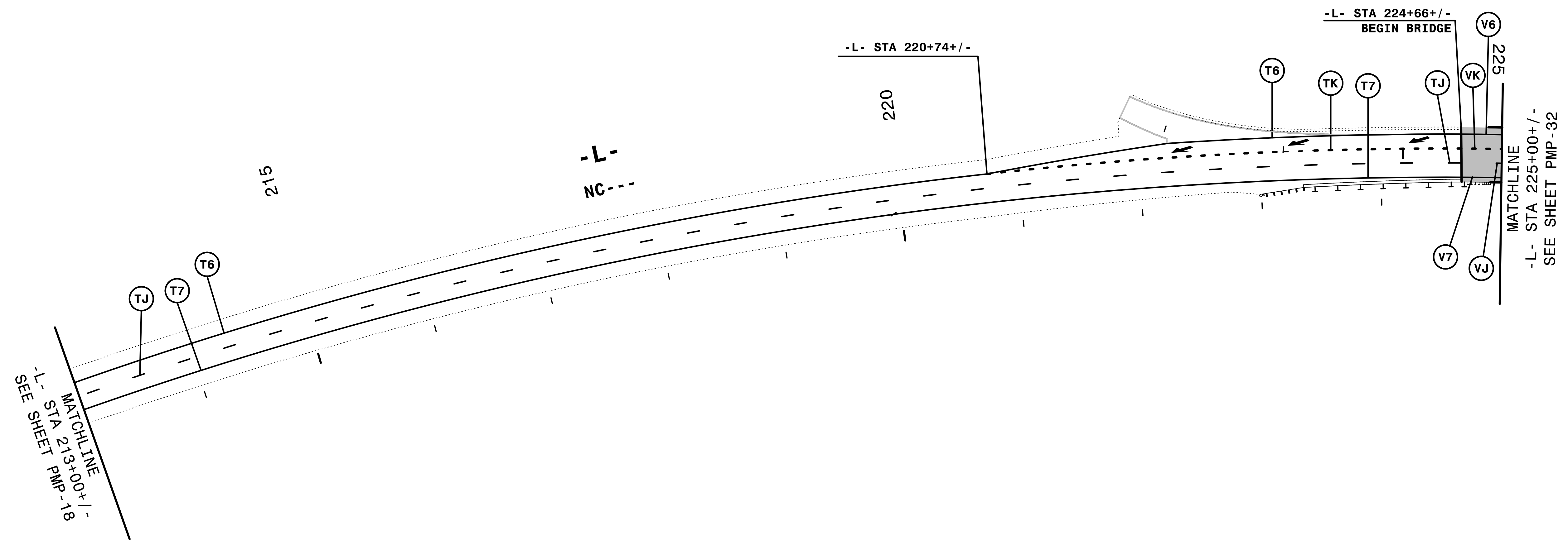
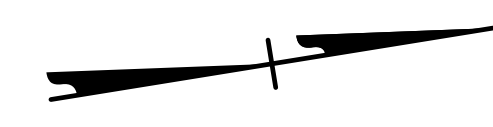

NOTE: ALL LANE WIDTHS ARE 12' UNLESS OTHERWISE SHOWN.

7/5/2017
P:\PMP\U4751_PMP_19.dgn
HNTB

HNTB
 HNTB NORTH CAROLINA, P.C.
 343 E. SIX FORKS ROAD, SUITE 200
 RALEIGH, NORTH CAROLINA 27609
 NC License No: C-1554
 (919) 546-8997

PAVEMENT MARKING DETAIL

TIP NO.	SHEET NO.
U-4751	PMP-20
APPROVED: <i>Andrew D. Klinkosich</i> E3078F84586E44B	
DATE: 7/5/2017	
	
DOCUMENT NOT CONSIDERED FINAL UNLESS ALL SIGNATURES COMPLETED	

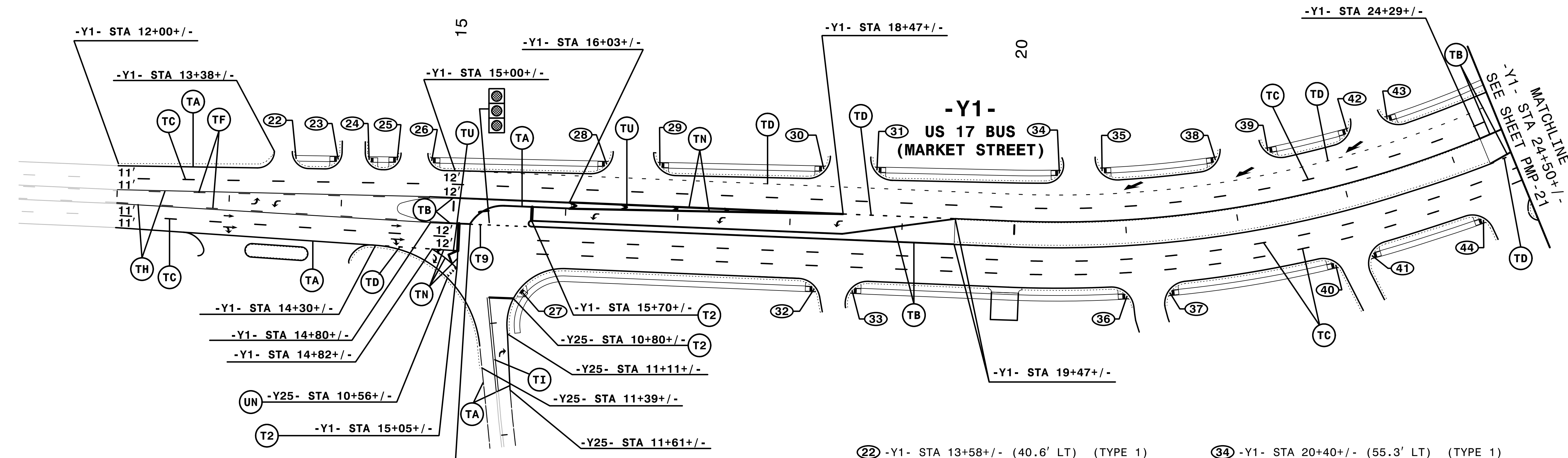

- | | |
|------------------------------------------|------------------------------------------|
| ②② -Y1- STA 13+58+/- (40.6' LT) (TYPE 1) | ③④ -Y1- STA 20+40+/- (55.3' LT) (TYPE 1) |
| ②③ -Y1- STA 13+95+/- (41.6' LT) (TYPE 1) | ③⑤ -Y1- STA 20+81+/- (56.5' LT) (TYPE 1) |
| ②④ -Y1- STA 14+23+/- (42.4' LT) (TYPE 1) | ③⑥ -Y1- STA 20+97+/- (56.5' RT) (TYPE 1) |
| ②⑤ -Y1- STA 14+48+/- (43.1' LT) (TYPE 1) | ③⑦ -Y1- STA 21+34+/- (56.5' RT) (TYPE 1) |
| ②⑥ -Y1- STA 14+79+/- (43.9' LT) (TYPE 1) | ③⑧ -Y1- STA 21+88+/- (56.5' LT) (TYPE 1) |
| ②⑦ -Y1- STA 15+63+/- (69.0' RT) (TYPE 3) | ③⑨ -Y1- STA 22+39+/- (56.5' LT) (TYPE 1) |
| ②⑧ -Y1- STA 16+35+/- (47.2' LT) (TYPE 1) | ④① -Y1- STA 22+76+/- (56.5' RT) (TYPE 1) |
| ②⑨ -Y1- STA 16+82+/- (48.1' LT) (TYPE 1) | ④② -Y1- STA 23+07+/- (56.5' RT) (TYPE 1) |
| ③① -Y1- STA 18+28+/- (51.1' LT) (TYPE 1) | ④③ -Y1- STA 23+16+/- (56.5' LT) (TYPE 1) |
| ③② -Y1- STA 18+24+/- (56.5' RT) (TYPE 1) | ④④ -Y1- STA 23+55+/- (56.5' LT) (TYPE 1) |
| ③③ -Y1- STA 18+58+/- (56.5' RT) (TYPE 1) | |

NOTE: ALL LANE WIDTHS ARE 12' UNLESS OTHERWISE SHOWN.

7/5/2017
P:\PMP\U4751_PMP_20.dgn
HNTB

HNTB
HNTB NORTH CAROLINA, P.C.
 343 E. SIX FORKS ROAD, SUITE 200
 RALEIGH, NORTH CAROLINA 27609
 NC LICENSE NO: C-1554
 (919) 546-8997

PAVEMENT MARKING DETAIL

TIP NO. U-4751	SHEET NO. PMP-21
APPROVED: <i>Andrew D. Klinck</i> E3078F8458E44B	
DATE: 7/5/2017	
	
DOCUMENT NOT CONSIDERED FINAL UNLESS ALL SIGNATURES COMPLETED	

- 45 -Y1- STA 24+50+/- (58.0' RT) (TYPE 1)
- 46 -Y1- STA 24+67+/- (56.5' LT) (TYPE 1)
- 47 -Y1- STA 25+02+/- (56.5' LT) (TYPE 1)
- 48 -Y1- STA 25+45+/- (56.9' LT) (TYPE 1)
- 49 -Y1- STA 25+74+/- (57.5' LT) (TYPE 1)
- 50 -Y1- STA 25+84+/- (58.0' RT) (TYPE 1)
- 51 -Y1- STA 26+17+/- (58.0' RT) (TYPE 1)
- 52 -Y1- STA 26+88+/- (59.8' LT) (TYPE 1)
- 53 -Y1- STA 27+35+/- (60.0' LT) (TYPE 1)
- 54 -Y1- STA 27+83+/- (70.0' RT) (TYPE 1)
- 55 -Y1- STA 28+31+/- (70.0' RT) (TYPE 1)
- 56 -Y1- STA 30+67+/- (72.4' RT) (TYPE 3)
- 57 -Y- STA 22+88+/- (45.6' RT) (TYPE 3)
- 58 -Y- STA 22+87+/- (71.1' LT) (TYPE 3)
- 59 -Y1- STA 30+16+/- (74.2' LT) (TYPE 3)
- 60 -Y- STA 19+93+/- (52.0' RT) (TYPE 1)
- 61 -Y- STA 19+60+/- (52.0' RT) (TYPE 1)
- 62 -Y1- STA 34+07+/- (56.5' RT) (TYPE 1)
- 63 -Y1- STA 34+54+/- (56.5' RT) (TYPE 1)
- 64 -Y1- STA 35+96+/- (56.5' RT) (TYPE 1)
- 65 -Y1- STA 36+40+/- (56.5' RT) (TYPE 1)

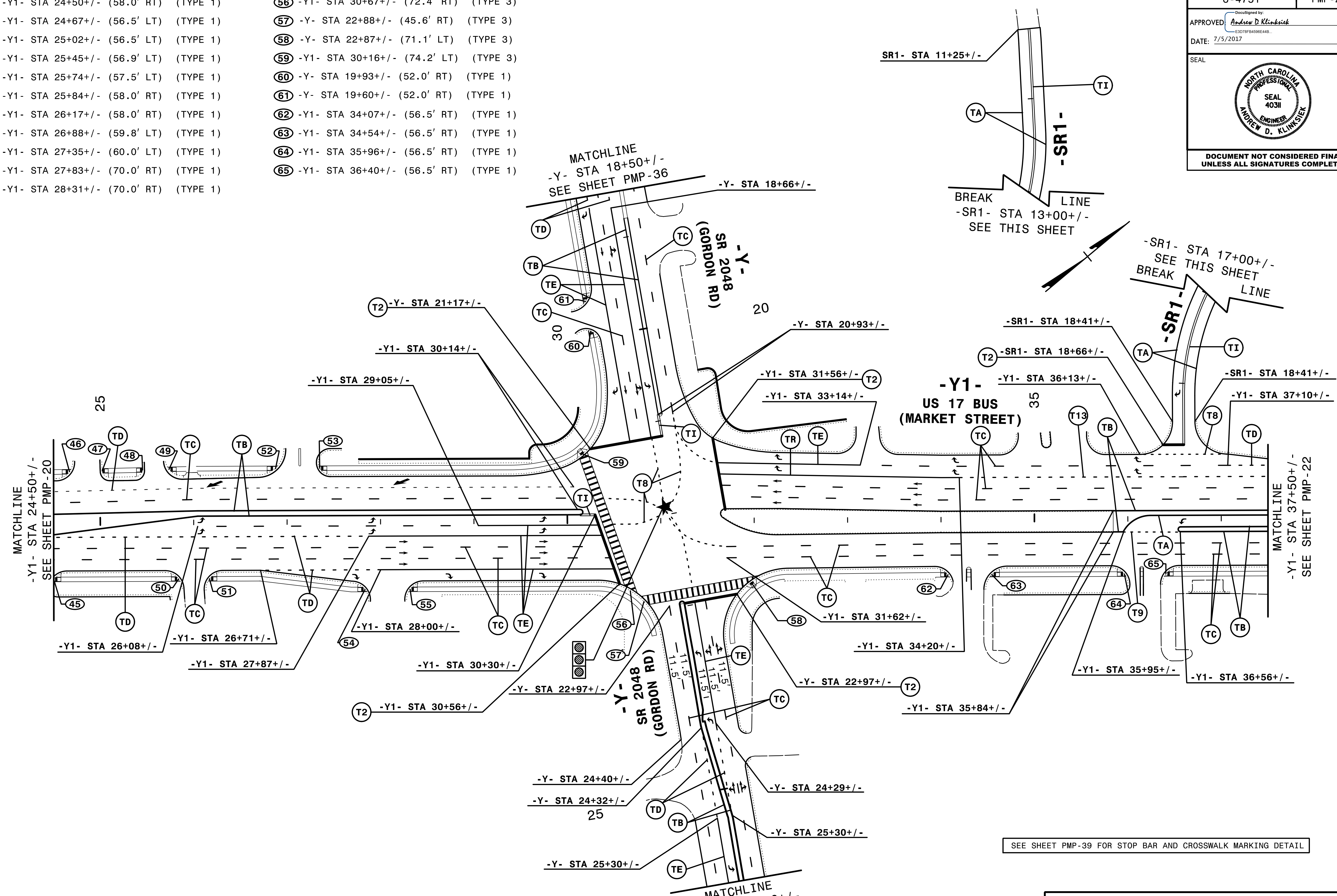

NOTE: ALL LANE WIDTHS ARE 12' UNLESS OTHERWISE SHOWN.

SEE SHEET PMP-39 FOR STOP BAR AND CROSSWALK MARKING DETAIL

MATCHLINE
-Y- STA 26+00+/-
SEE SHEET PMP-4

HNTB

HNTB NORTH CAROLINA, P.C.
343 E. Six Forks Road, Suite 200
Raleigh, North Carolina 27609
NC License No: C-1554
(919) 546-8997

PAVEMENT MARKING DETAIL

7/5/2017
PMP-U4751_PMP_21.dgn
HNTB

TIP NO. U-4751	SHEET NO. PMP-22
APPROVED: <i>Andrew D. Klinck</i> E3078F84586E44B	
DATE: 7/5/2017	
	
DOCUMENT NOT CONSIDERED FINAL UNLESS ALL SIGNATURES COMPLETED	

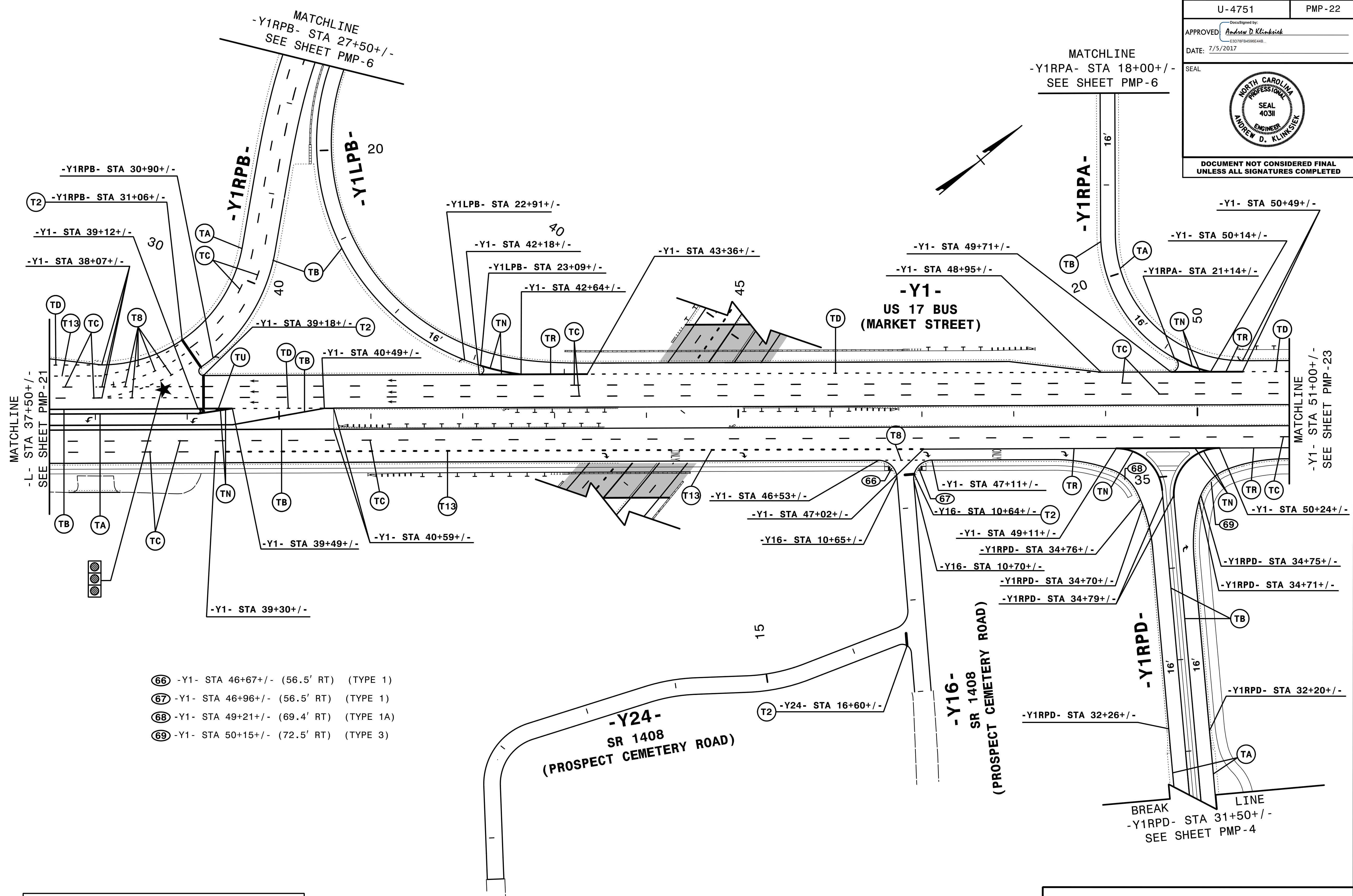

- ⑥⑥ -Y1- STA 46+67+/- (56.5' RT) (TYPE 1)
- ⑥⑦ -Y1- STA 46+96+/- (56.5' RT) (TYPE 1)
- ⑥⑧ -Y1- STA 49+21+/- (69.4' RT) (TYPE 1A)
- ⑥⑨ -Y1- STA 50+15+/- (72.5' RT) (TYPE 3)

NOTE: ALL LANE WIDTHS ARE 12' UNLESS OTHERWISE SHOWN.

7/5/2017
PMP-U4751_PMP_22.dgn
HNTB

HNTB
 HNTB NORTH CAROLINA, P.C.
 343 E. Six Forks Road, Suite 200
 Raleigh, North Carolina 27609
 NC License No: C-1554
 (919) 546-8997

PAVEMENT MARKING DETAIL

TIP NO. U-4751	SHEET NO. PMP-23
APPROVED: <i>Andrew D. Klinkosiek</i> E3078FB4586E44B	
DATE: 7/5/2017	
	
DOCUMENT NOT CONSIDERED FINAL UNLESS ALL SIGNATURES COMPLETED	

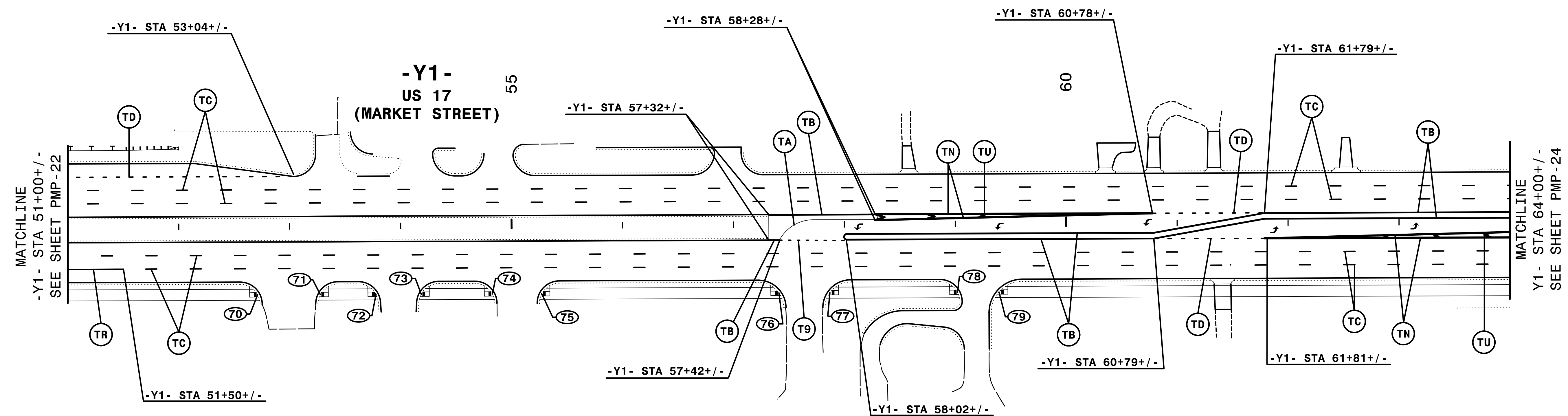
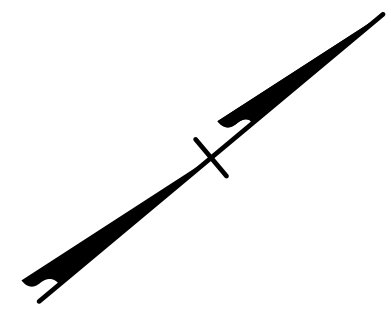

- ⑦⑩ -Y1- STA 52+71+/- (59.0' RT) (TYPE 1)
- ⑦① -Y1- STA 53+27+/- (59.0' RT) (TYPE 1)
- ⑦② -Y1- STA 53+78+/- (59.0' RT) (TYPE 1)
- ⑦③ -Y1- STA 54+18+/- (59.0' RT) (TYPE 1)
- ⑦④ -Y1- STA 54+83+/- (59.0' RT) (TYPE 1)
- ⑦⑤ -Y1- STA 55+27+/- (59.0' RT) (TYPE 1)
- ⑦⑥ -Y1- STA 57+41+/- (59.0' RT) (TYPE 1)
- ⑦⑦ -Y1- STA 57+87+/- (59.0' RT) (TYPE 1)
- ⑦⑧ -Y1- STA 59+02+/- (59.0' RT) (TYPE 1)
- ⑦⑨ -Y1- STA 59+39+/- (59.0' RT) (TYPE 1)

NOTE: ALL LANE WIDTHS ARE 12' UNLESS OTHERWISE SHOWN.

HNTB
HNTB NORTH CAROLINA, P.C.
 343 E. Six Forks Road, Suite 200
 Raleigh, North Carolina 27609
 NC License No: C-1554
 (919) 546-8997

PAVEMENT MARKING DETAIL

7/5/2017
 PMP-U4751_PMP_23.dgn
 HNTB

TIP NO. U-4751	SHEET NO. PMP-24
APPROVED: <i>Andrew D. Klinskiak</i> E3078FB4586E44B	
DATE: 7/5/2017	
	
DOCUMENT NOT CONSIDERED FINAL UNLESS ALL SIGNATURES COMPLETED	

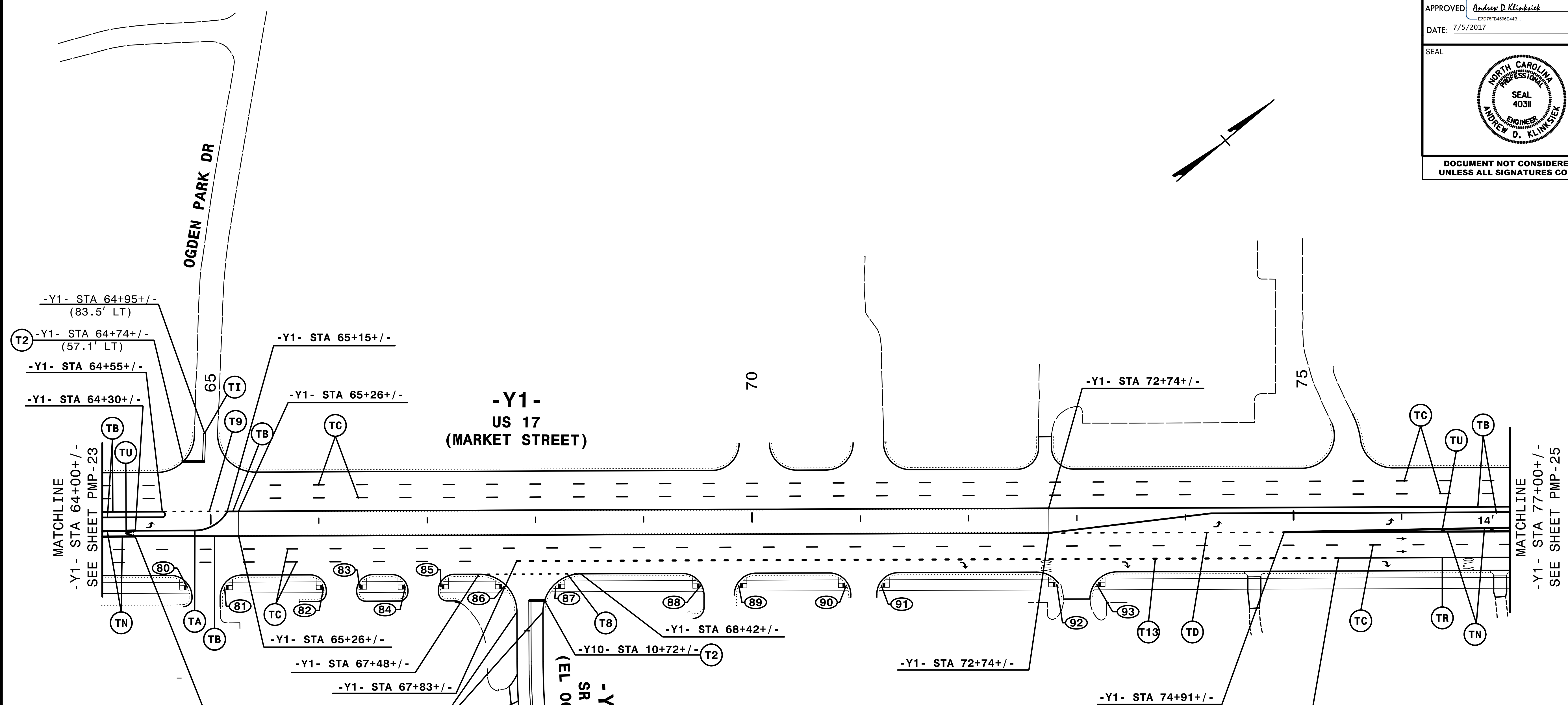

- 80 -Y1- STA 64+78+/- (59.0' RT) (TYPE 1)
- 81 -Y1- STA 65+13+/- (59.0' RT) (TYPE 1)
- 82 -Y1- STA 66+04+/- (59.0' RT) (TYPE 1)
- 83 -Y1- STA 66+37+/- (59.0' RT) (TYPE 1)
- 84 -Y1- STA 66+80+/- (59.0' RT) (TYPE 1)
- 85 -Y1- STA 67+12+/- (59.0' RT) (TYPE 1)
- 86 -Y1- STA 67+71+/- (59.0' RT) (TYPE 1)
- 87 -Y1- STA 68+18+/- (59.0' RT) (TYPE 1)
- 88 -Y1- STA 69+52+/- (59.0' RT) (TYPE 1)
- 89 -Y1- STA 69+87+/- (59.0' RT) (TYPE 1)
- 90 -Y1- STA 70+87+/- (59.0' RT) (TYPE 1)
- 91 -Y1- STA 71+19+/- (59.0' RT) (TYPE 1)
- 92 -Y1- STA 72+81+/- (59.0' RT) (TYPE 1)
- 93 -Y1- STA 73+18+/- (59.0' RT) (TYPE 1)

NOTE: ALL LANE WIDTHS ARE 12' UNLESS OTHERWISE SHOWN.

HNTB
 HNTB NORTH CAROLINA, P.C.
 343 E. Six Forks Road, Suite 200
 Raleigh, North Carolina 27609
 NC License No: C-1554
 (919) 546-8997

PAVEMENT MARKING DETAIL

7/5/2017
 P:\PMP\U4751_PMP_24.dgn
 HNTB

TIP NO. U-4751	SHEET NO. PMP-25
APPROVED: <i>Andrew D. Klinsky</i> E3078F84586E44B	
DATE: 7/5/2017	
SEAL 	
DOCUMENT NOT CONSIDERED FINAL UNLESS ALL SIGNATURES COMPLETED	

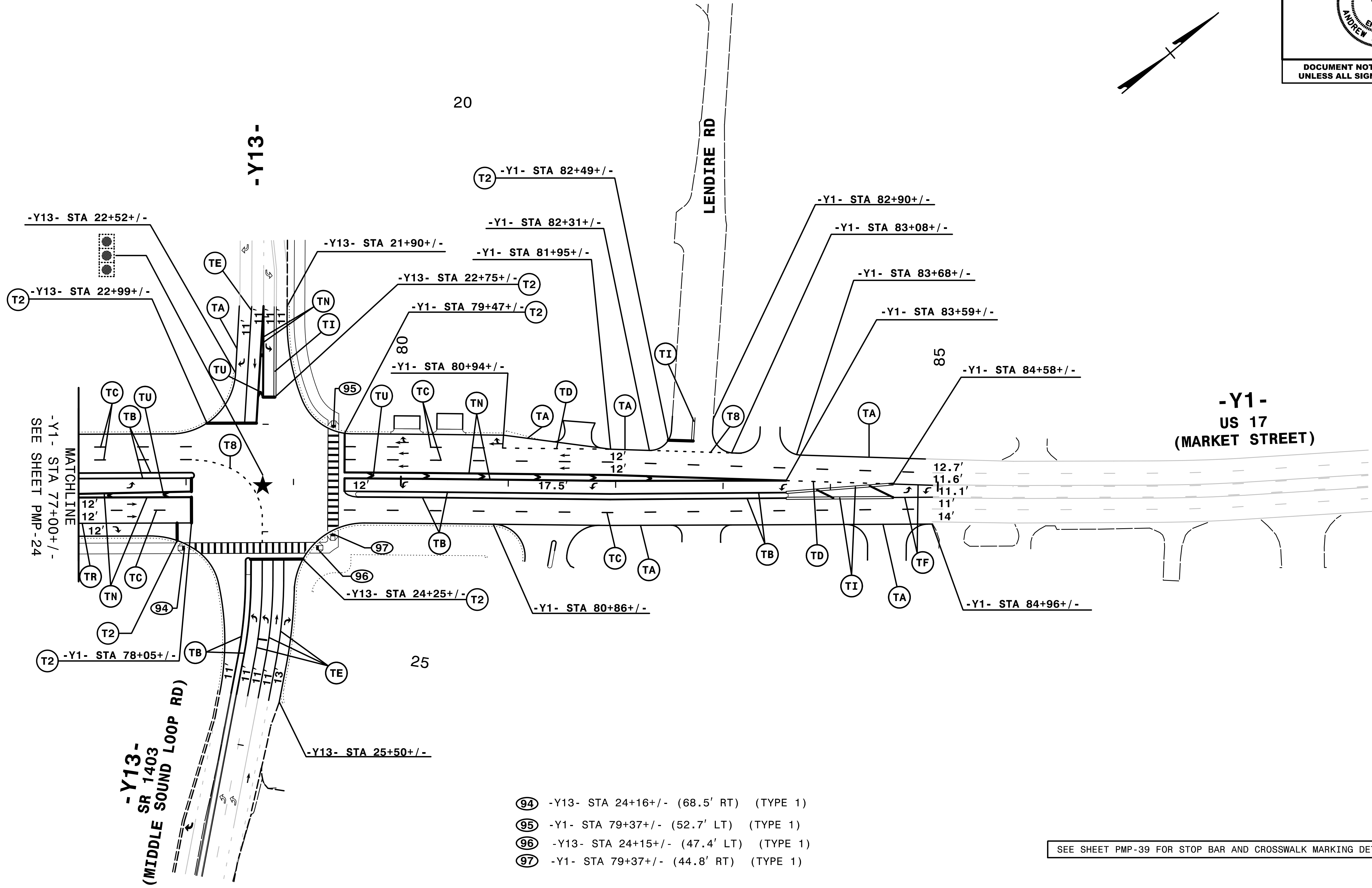

- 94 -Y13- STA 24+16+/- (68.5' RT) (TYPE 1)
- 95 -Y1- STA 79+37+/- (52.7' LT) (TYPE 1)
- 96 -Y13- STA 24+15+/- (47.4' LT) (TYPE 1)
- 97 -Y1- STA 79+37+/- (44.8' RT) (TYPE 1)

SEE SHEET PMP-39 FOR STOP BAR AND CROSSWALK MARKING DETAIL

NOTE: ALL LANE WIDTHS ARE 12' UNLESS OTHERWISE SHOWN.

HNTB
 HNTB NORTH CAROLINA, P.C.
 343 E. Six Forks Road, Suite 200
 Raleigh, North Carolina 27609
 NC License No: C-1554
 (919) 546-8997

PAVEMENT MARKING DETAIL

7/5/2017
 P:\PMP\U4751_PMP_25.dgn
 HNTB

TIP NO. U-4751	SHEET NO. PMP-26
APPROVED: <u>Andrew D. Klinsky</u> <small>E3078F84586E44B</small>	
DATE: 7/5/2017	
	
DOCUMENT NOT CONSIDERED FINAL UNLESS ALL SIGNATURES COMPLETED	

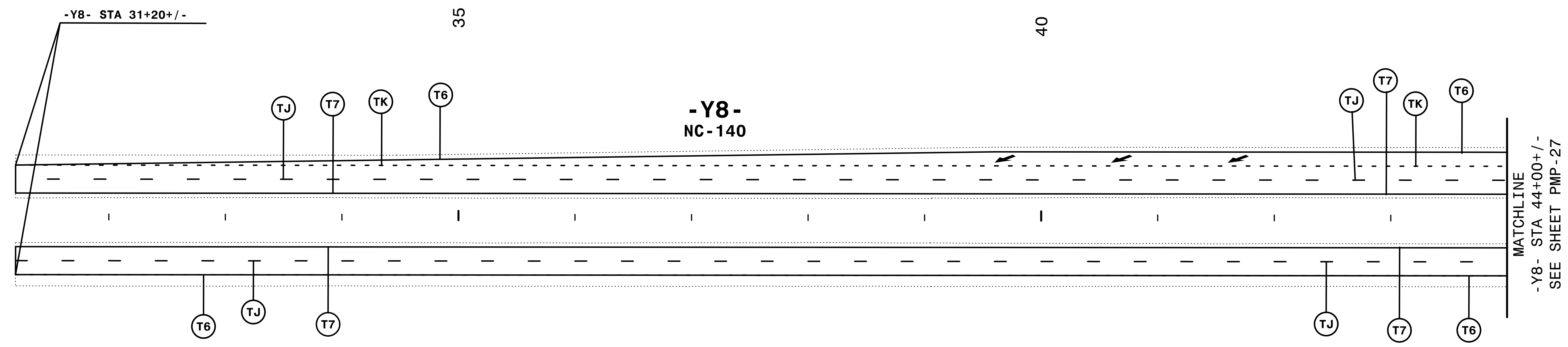
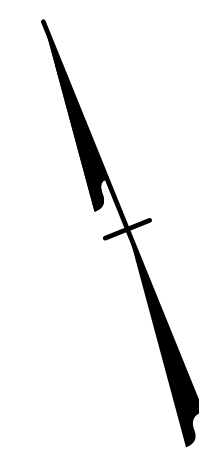

NOTE: ALL LANE WIDTHS ARE 12' UNLESS OTHERWISE SHOWN.

7/5/2017
 P:\PMP\U4751_PMP_26.dgn
 HNTB

HNTB HNTB NORTH CAROLINA, P.C.
 343 E. SIX FORKS ROAD, SUITE 200
 RALEIGH, NORTH CAROLINA 27609
 NC LICENSE NO: C-1554
 (919) 546-8997

PAVEMENT MARKING DETAIL

TIP NO. U-4751	SHEET NO. PMP-27
APPROVED: <i>Andrew D. Klinksieck</i> <small>E3078FB4586E44B</small>	
DATE: 7/5/2017	
	
DOCUMENT NOT CONSIDERED FINAL UNLESS ALL SIGNATURES COMPLETED	

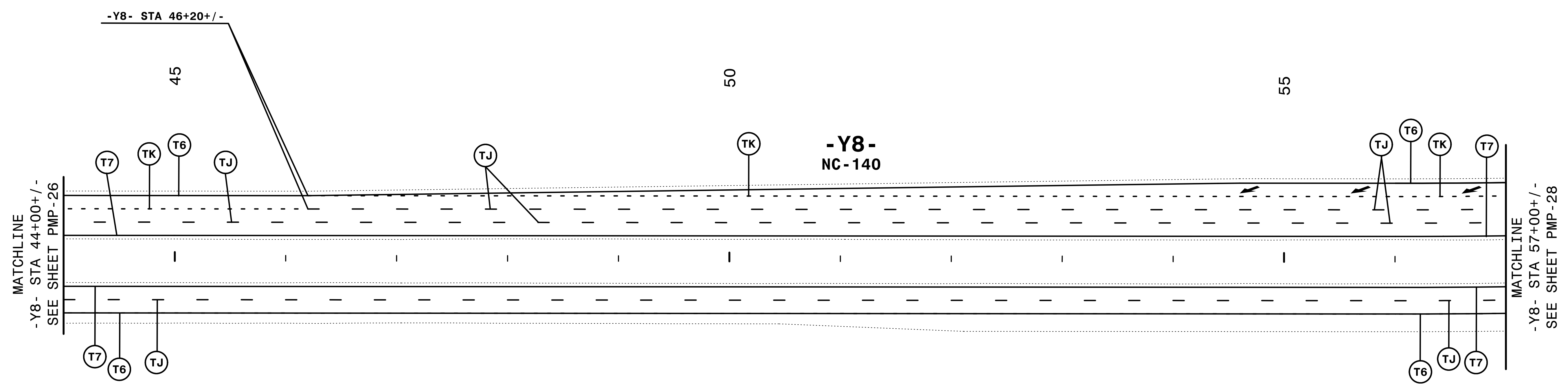
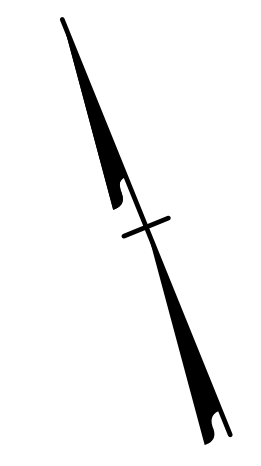

NOTE: ALL LANE WIDTHS ARE 12' UNLESS OTHERWISE SHOWN.

7/5/2017
P:\PMP\U4751_PMP_27.dgn
HNTB

HNTB HNTB NORTH CAROLINA, P.C.
343 E. SIX FORKS ROAD, SUITE 200
RALEIGH, NORTH CAROLINA 27609
NC LICENSE NO: C-1554
(919) 546-8997

PAVEMENT MARKING DETAIL

TIP NO. U-4751	SHEET NO. PMP-28
APPROVED: <i>Andrew D. Klinkosiek</i> E3078FB4586E44B	
DATE: 7/5/2017	
	
DOCUMENT NOT CONSIDERED FINAL UNLESS ALL SIGNATURES COMPLETED	

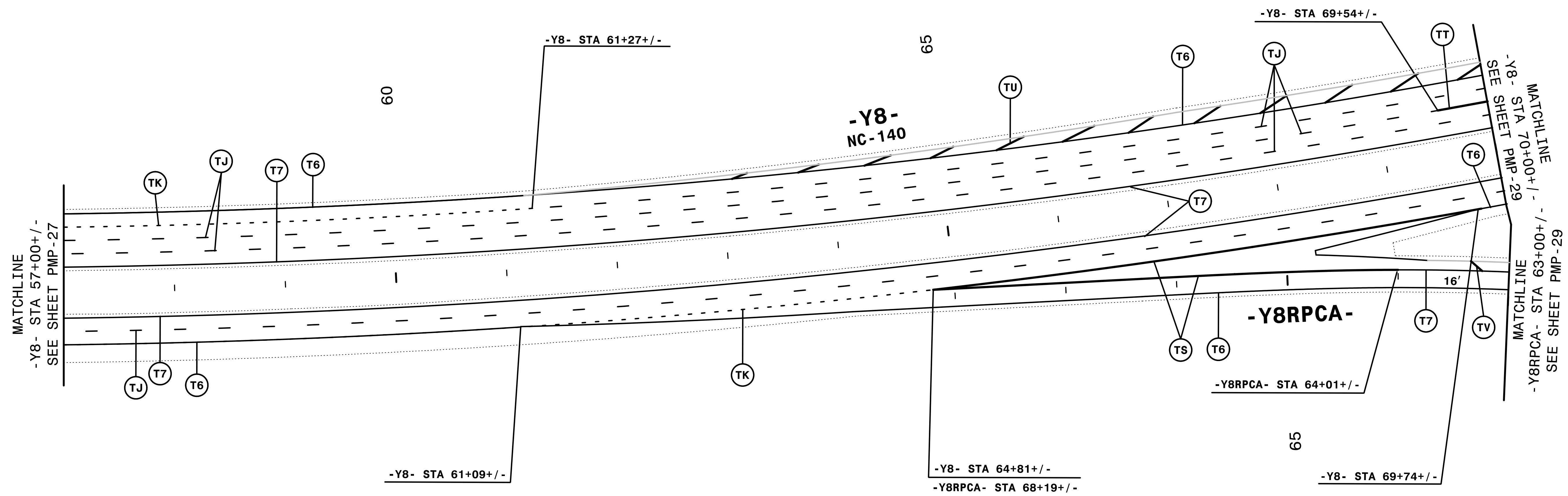

NOTE: ALL LANE WIDTHS ARE 12' UNLESS OTHERWISE SHOWN.

7/5/2017
PMP\U4751_PMP_28.dgn
HNTB

HNTB
 HNTB NORTH CAROLINA, P.C.
 343 E. SIX FORKS ROAD, SUITE 200
 RALEIGH, NORTH CAROLINA 27609
 NC License No: C-1554
 (919) 546-8997

PAVEMENT MARKING DETAIL

TIP NO. U-4751	SHEET NO. PMP-29
APPROVED: <i>Andrew D. Klinck</i> E3078F84586E44B	
DATE: 7/5/2017	
	
DOCUMENT NOT CONSIDERED FINAL UNLESS ALL SIGNATURES COMPLETED	

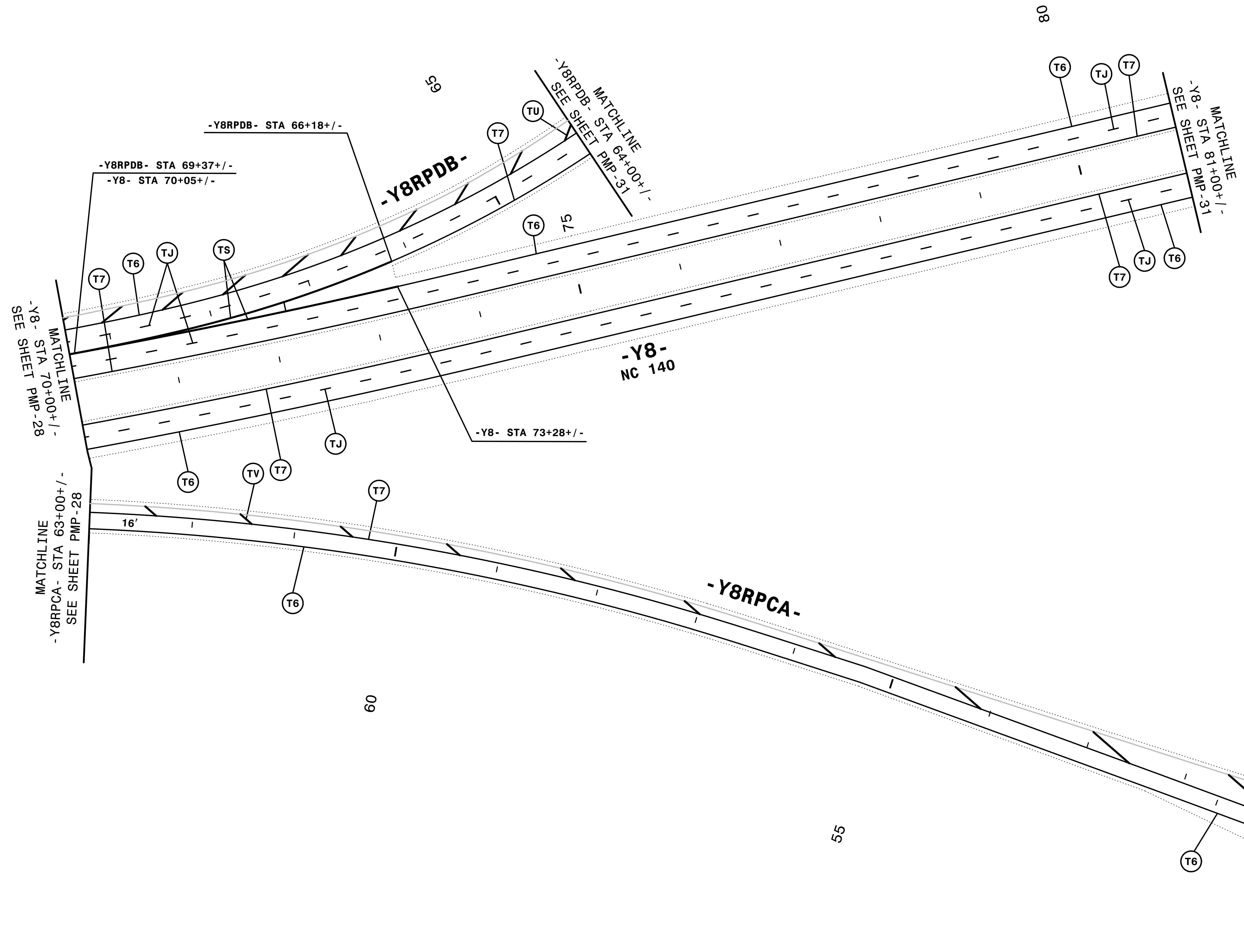

NOTE: ALL LANE WIDTHS ARE 12' UNLESS OTHERWISE SHOWN.

7/5/2017
P:\PMP\U4751_PMP_29.dgn
HNTB

HNTB
 HNTB NORTH CAROLINA, P.C.
 343 E. SIX FORKS ROAD, SUITE 200
 RALEIGH, NORTH CAROLINA 27609
 NC LICENSE NO: C-1554
 (919) 546-8997

PAVEMENT MARKING DETAIL

TIP NO. U-4751	SHEET NO. PMP-30
APPROVED: <u>Andrew D. Klinkusiek</u> <small>E3078FB4586E44B</small>	
DATE: 7/5/2017	
SEAL	
	
DOCUMENT NOT CONSIDERED FINAL UNLESS ALL SIGNATURES COMPLETED	

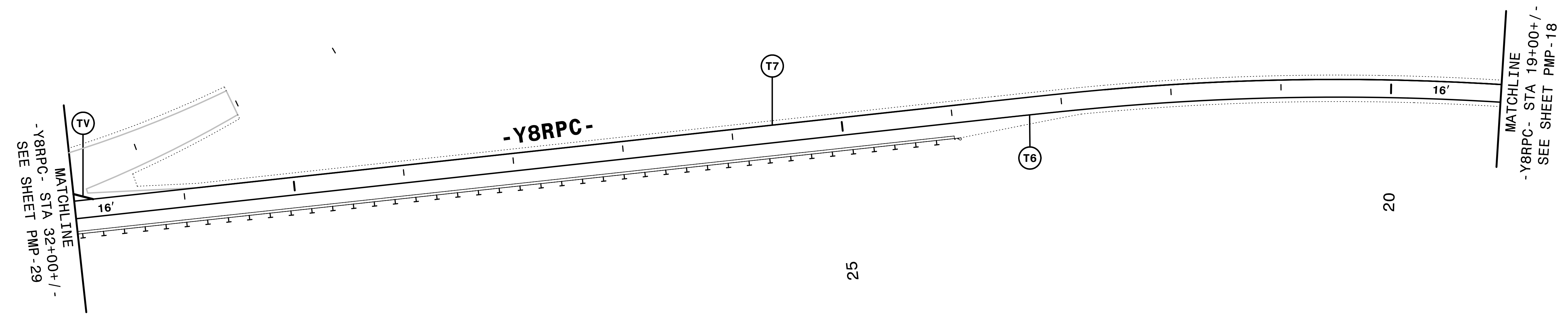

MATCHLINE
-Y8RPC- STA 32+00+/-
SEE SHEET PMP-29

MATCHLINE
-Y8RPC- STA 19+00+/-
SEE SHEET PMP-18

NOTE: ALL LANE WIDTHS ARE 12' UNLESS OTHERWISE SHOWN.

7/5/2017
PMP-U4751_PMP_30.dgn
HNTB

HNTB HNTB NORTH CAROLINA, P.C.
343 E. SIX FORKS ROAD, SUITE 200
RALEIGH, NORTH CAROLINA 27609
NC LICENSE NO: C-1554
(919) 546-8997

PAVEMENT MARKING DETAIL

TIP NO. U-4751	SHEET NO. PMP-31
APPROVED: <i>Andrew D. Klinck</i> E3078FB459E44B	
DATE: 7/5/2017	
	
DOCUMENT NOT CONSIDERED FINAL UNLESS ALL SIGNATURES COMPLETED	

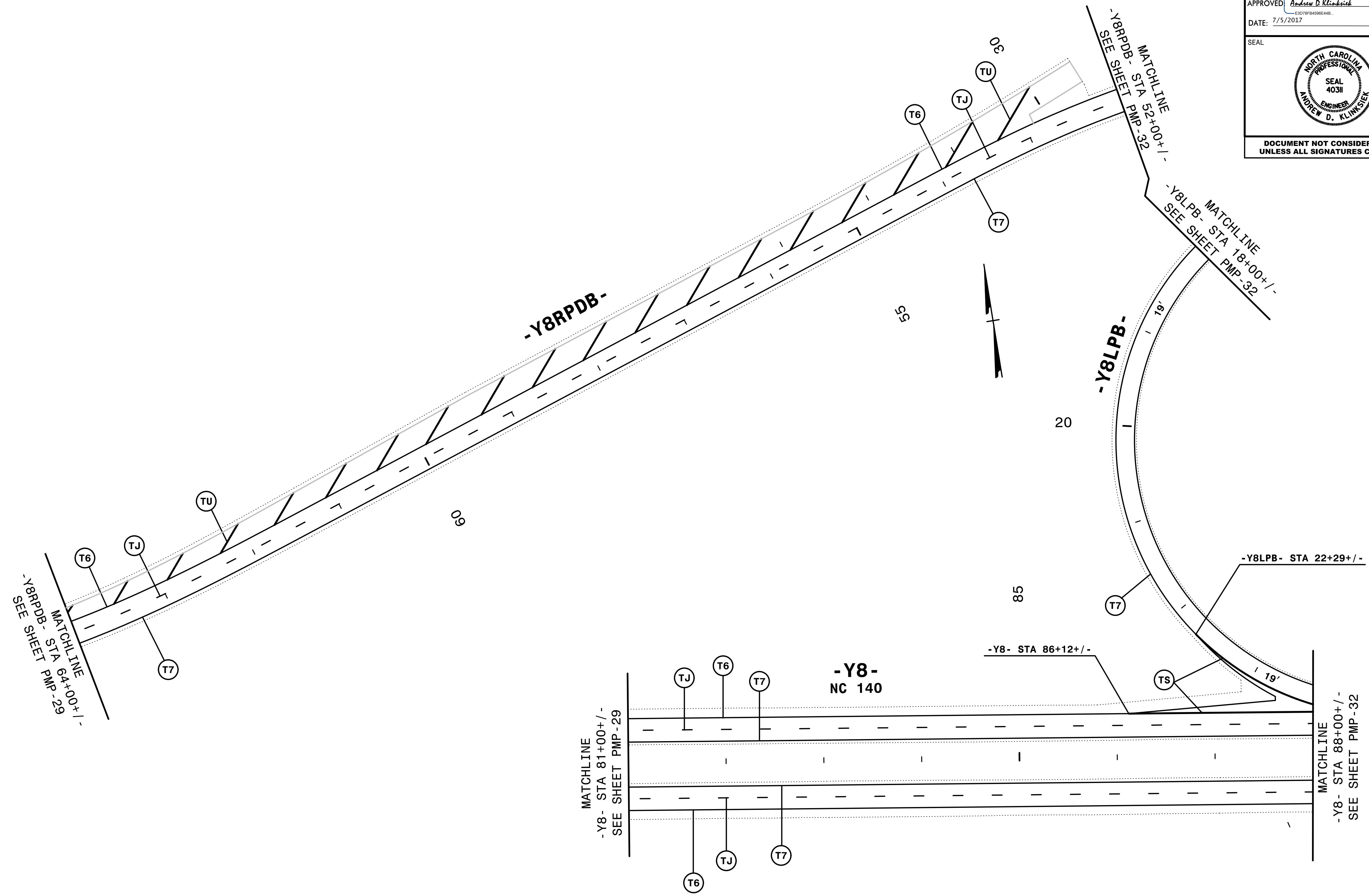

NOTE: ALL LANE WIDTHS ARE 12' UNLESS OTHERWISE SHOWN.

7/5/2017
P:\PMP\U4751_PMP_31.dgn
HNTB

HNTB HNTB NORTH CAROLINA, P.C.
343 E. Six Forks Road, Suite 200
Raleigh, North Carolina 27609
NC License No: C-1554
(919) 546-8997

PAVEMENT MARKING DETAIL

TIP NO. U-4751	SHEET NO. PMP-32
APPROVED: <i>Andrew D. Klinksieck</i> E3078FB4586E44B	
DATE: 7/5/2017	
	
DOCUMENT NOT CONSIDERED FINAL UNLESS ALL SIGNATURES COMPLETED	

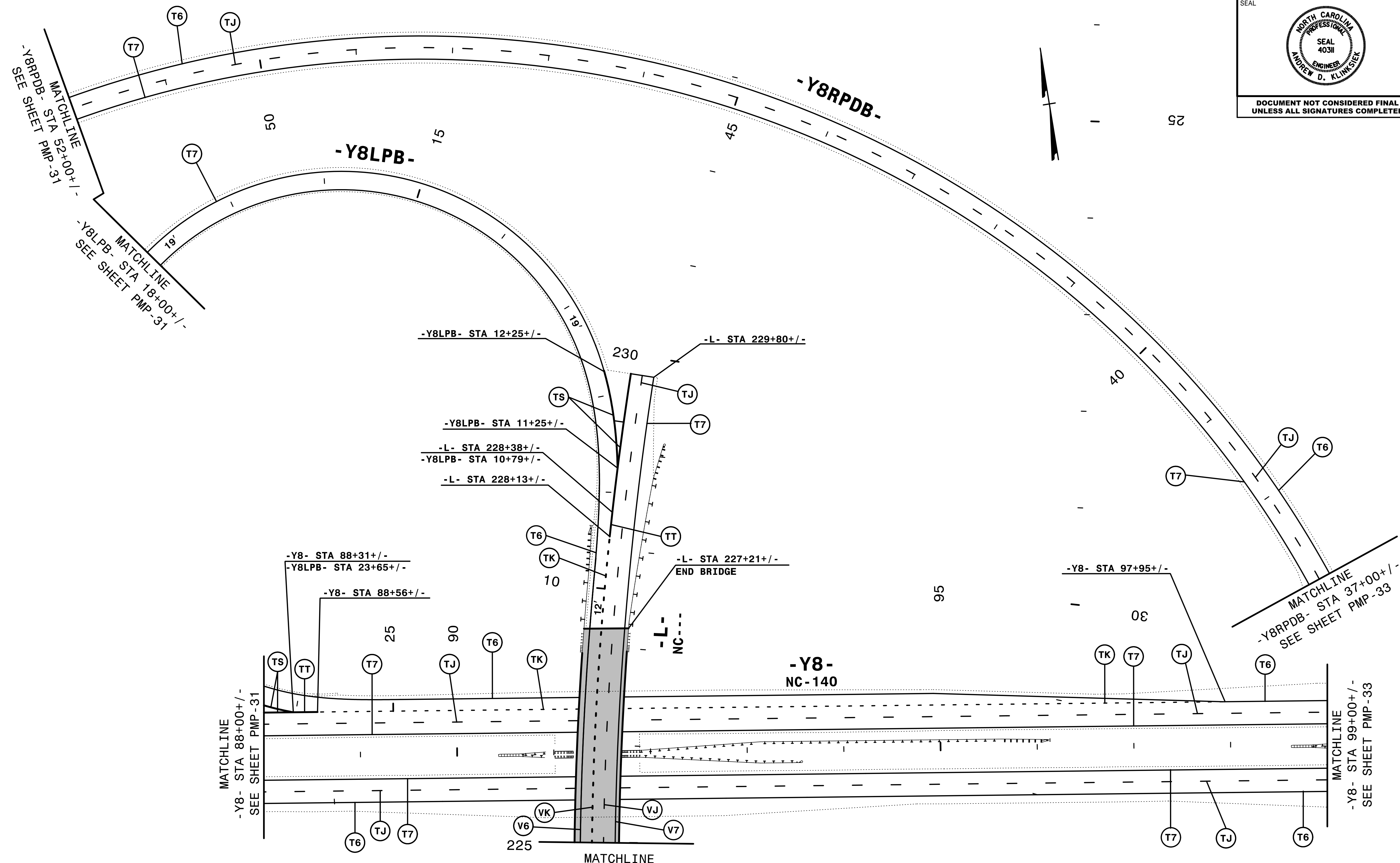

NOTE: ALL LANE WIDTHS ARE 12' UNLESS OTHERWISE SHOWN.

MATCHLINE
-L- STA 225+00+/-
SEE SHEET PMP-19

HNTB
 HNTB NORTH CAROLINA, P.C.
 343 E. Six Forks Road, Suite 200
 Raleigh, North Carolina 27609
 NC License No: C-1554
 (919) 546-8997

PAVEMENT MARKING DETAIL

7/5/2017
PMP-U4751_PMP_32.dgn
HNTB

TIP NO. U-4751	SHEET NO. PMP-33
APPROVED: <i>Andrew D. Klinskiak</i> E3078FB4586E44B	
DATE: 7/5/2017	
SEAL	
	
DOCUMENT NOT CONSIDERED FINAL UNLESS ALL SIGNATURES COMPLETED	

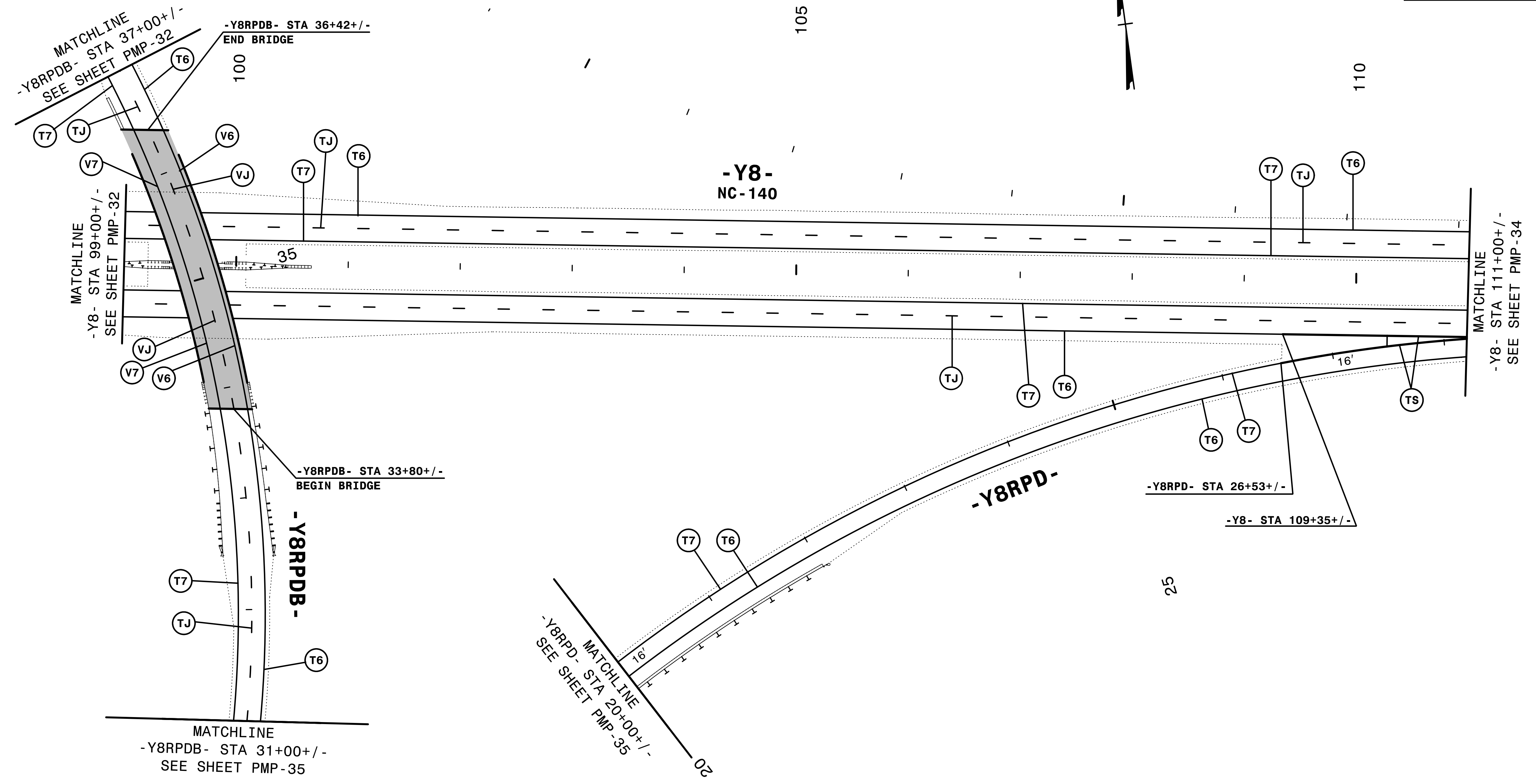

NOTE: ALL LANE WIDTHS ARE 12' UNLESS OTHERWISE SHOWN.

7/5/2017
PMP-U4751_PMP_33.dgn
HNTB

HNTB
 HNTB NORTH CAROLINA, P.C.
 343 E. SIX FORKS ROAD, SUITE 200
 RALEIGH, NORTH CAROLINA 27609
 NC LICENSE NO: C-1554
 (919) 546-8997

PAVEMENT MARKING DETAIL

TIP NO. U-4751	SHEET NO. PMP-34
APPROVED: <i>Andrew D. Klinck</i> E3078FB4596E44B	
DATE: 7/5/2017	
	
DOCUMENT NOT CONSIDERED FINAL UNLESS ALL SIGNATURES COMPLETED	

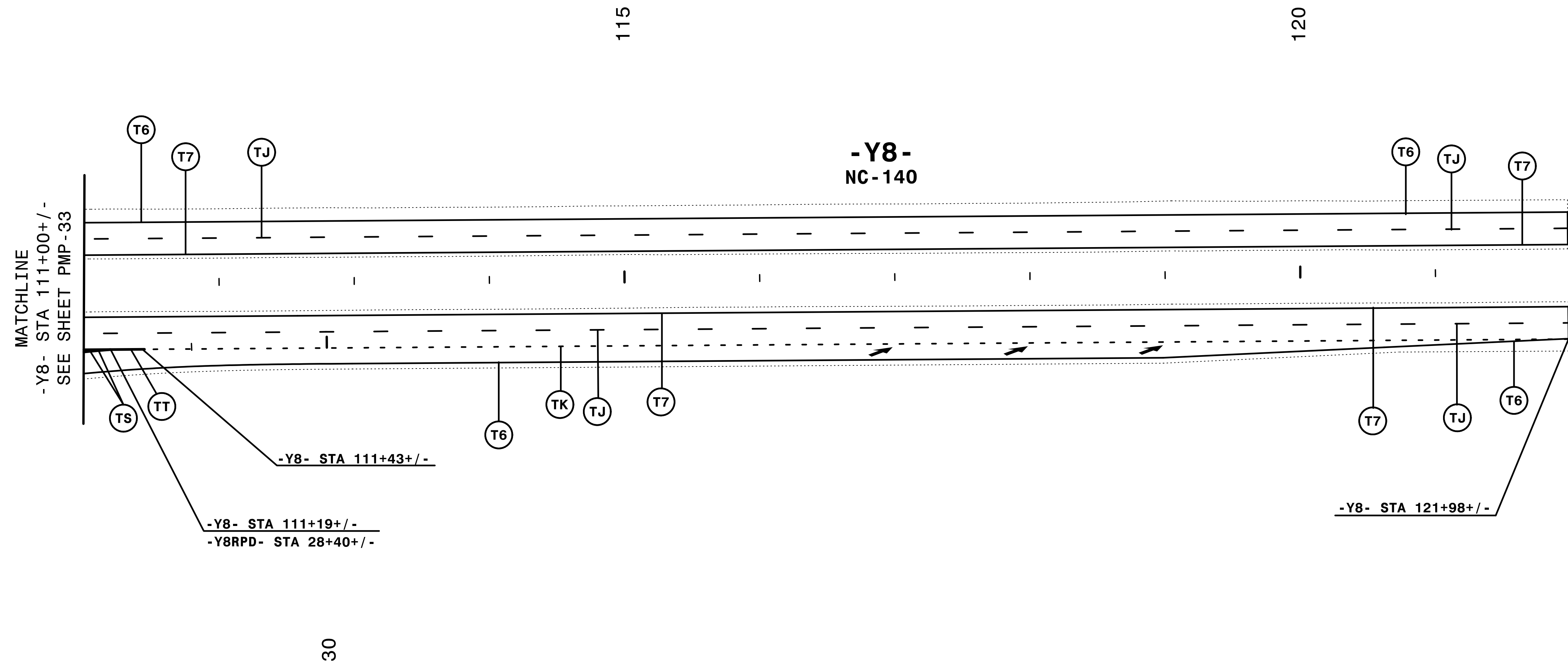

NOTE: ALL LANE WIDTHS ARE 12' UNLESS OTHERWISE SHOWN.

HNTB
 HNTB NORTH CAROLINA, P.C.
 343 E. SIX FORKS ROAD, SUITE 200
 RALEIGH, NORTH CAROLINA 27609
 NC License No: C-1554
 (919) 546-8997

PAVEMENT MARKING DETAIL

7/5/2017
PMP\U4751_PMP_34.dgn
HNTB

TIP NO. U-4751	SHEET NO. PMP-35
APPROVED: <i>Andrew D. Klinkosiek</i> <small>E3078FB4586E44B</small>	
DATE: 7/5/2017	
	
DOCUMENT NOT CONSIDERED FINAL UNLESS ALL SIGNATURES COMPLETED	

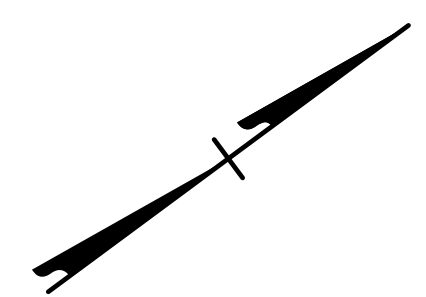
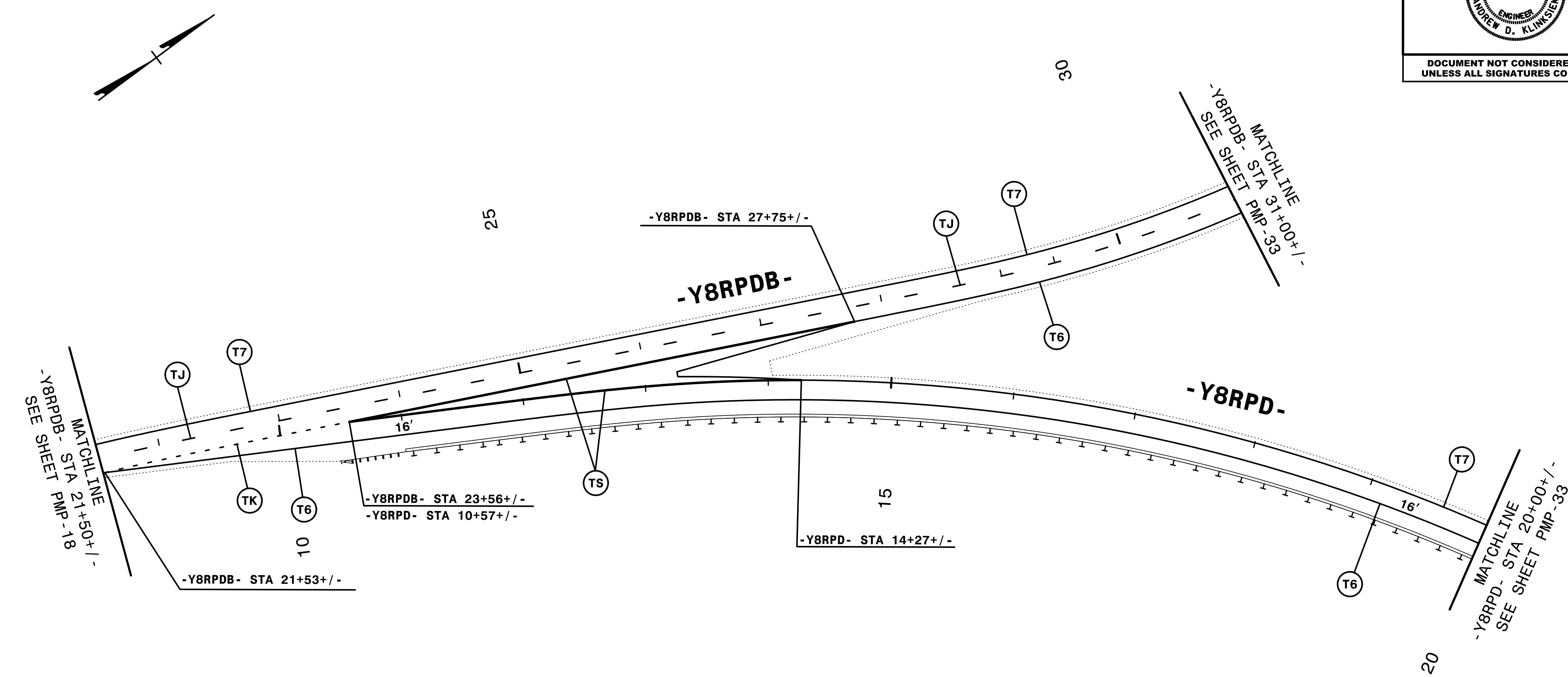

NOTE: ALL LANE WIDTHS ARE 12' UNLESS OTHERWISE SHOWN.

7/5/2017
P:\PMP\U4751_PMP_35.dgn
HNTB

HNTB
 HNTB NORTH CAROLINA, P.C.
 343 E. SIX FORKS ROAD, SUITE 200
 RALEIGH, NORTH CAROLINA 27609
 NC License No: C-1554
 (919) 546-8997

PAVEMENT MARKING DETAIL

TIP NO. U-4751	SHEET NO. PMP-36
APPROVED: <i>Andrew D. Klinkosich</i> E3078FB4586E44B	
DATE: 7/5/2017	
SEAL	
	
DOCUMENT NOT CONSIDERED FINAL UNLESS ALL SIGNATURES COMPLETED	

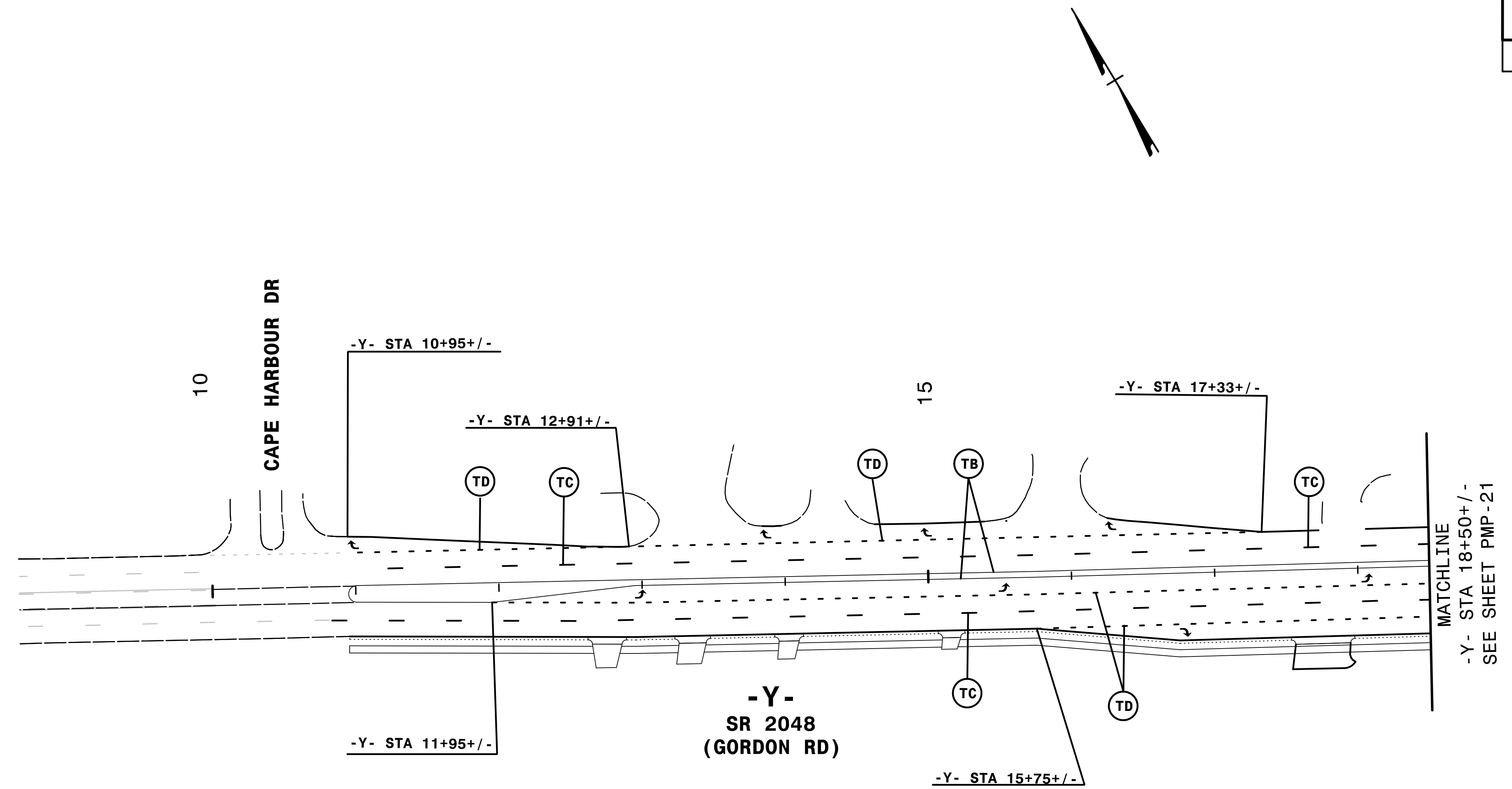

NOTE: ALL LANE WIDTHS ARE 12' UNLESS OTHERWISE SHOWN.

7/5/2017
PMP-U4751_PMP_36.dgn
HNTB

HNTB HNTB NORTH CAROLINA, P.C.
343 E. SIX FORKS ROAD, SUITE 200
RALEIGH, NORTH CAROLINA 27609
NC LICENSE NO: C-1554
(919) 546-8997

PAVEMENT MARKING DETAIL

TIP NO. U-4751	SHEET NO. PMP-37
APPROVED: <i>Andrew D. Klinkosich</i> E3078FB4586E44B	
DATE: 7/5/2017	
SEAL 	
DOCUMENT NOT CONSIDERED FINAL UNLESS ALL SIGNATURES COMPLETED	

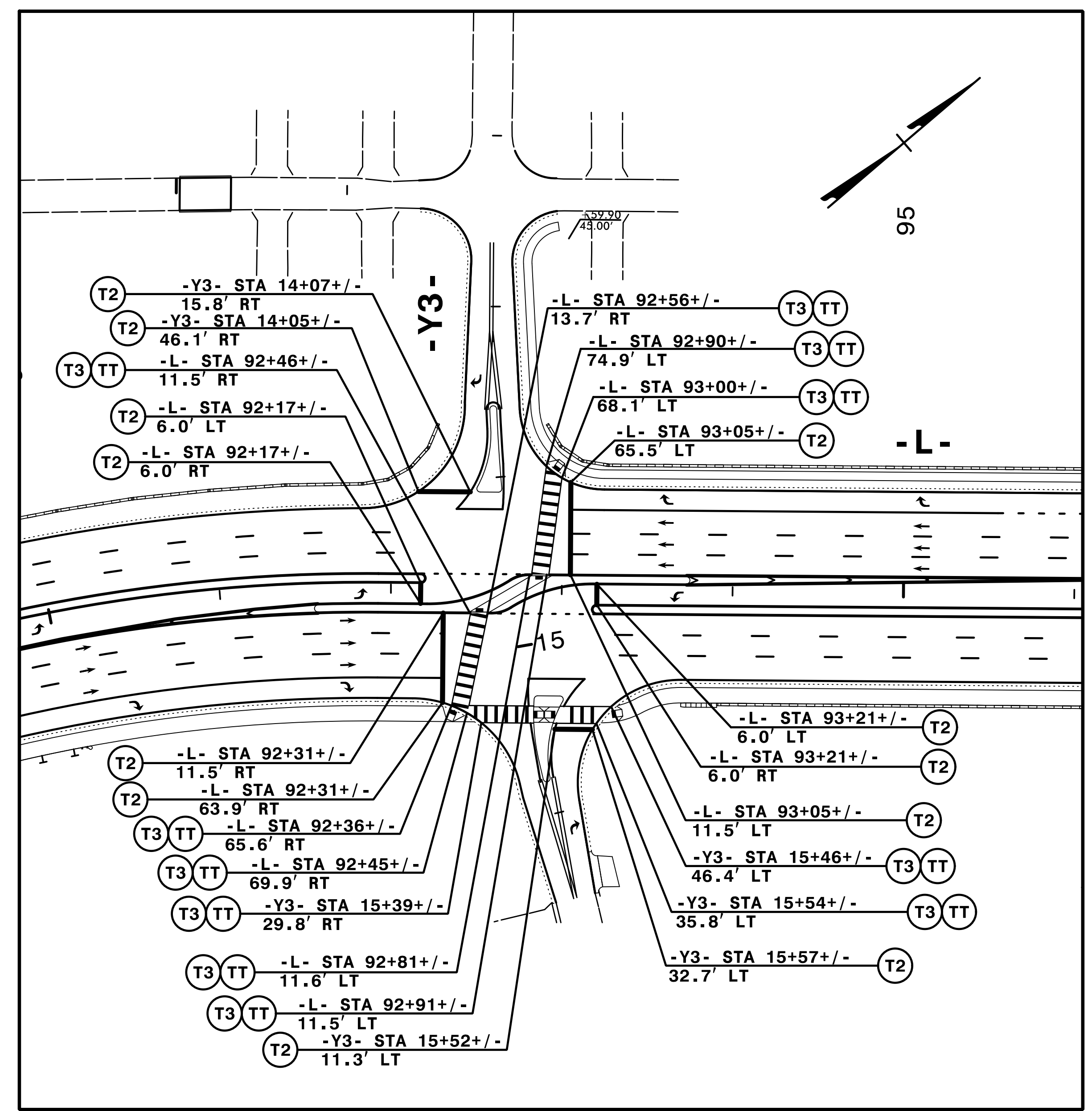

-L- (NC---) / -Y3- (BRADFIELD CT/PUTNAM DR)

SEE SHEET PMP-9 FOR ADDITIONAL STATIONING

SEE SHEET PMP-2 FOR CROSSWALK DETAILS

7/5/2017
PMP-U4751_PMP_37.dgn
HNTB

HNTB
HNTB NORTH CAROLINA, P.C.
 343 E. SIX FORKS ROAD, SUITE 200
 RALEIGH, NORTH CAROLINA 27609
 NC LICENSE NO: C-1554
 (919) 546-8997

**PAVEMENT MARKING DETAIL
STOP BAR AND CROSSWALK
LOCATIONS**

TIP NO. U-4751	SHEET NO. PMP-38
APPROVED: <i>Andrew D. Klinck</i> E3078F84586E44B	
DATE: 7/5/2017	
	
DOCUMENT NOT CONSIDERED FINAL UNLESS ALL SIGNATURES COMPLETED	

-L- (NC---) / -Y4- (SR 2722)

SEE SHEET PMP-2 FOR CROSSWALK DETAILS

SEE SHEET PMP-11 FOR ADDITIONAL STATIONING

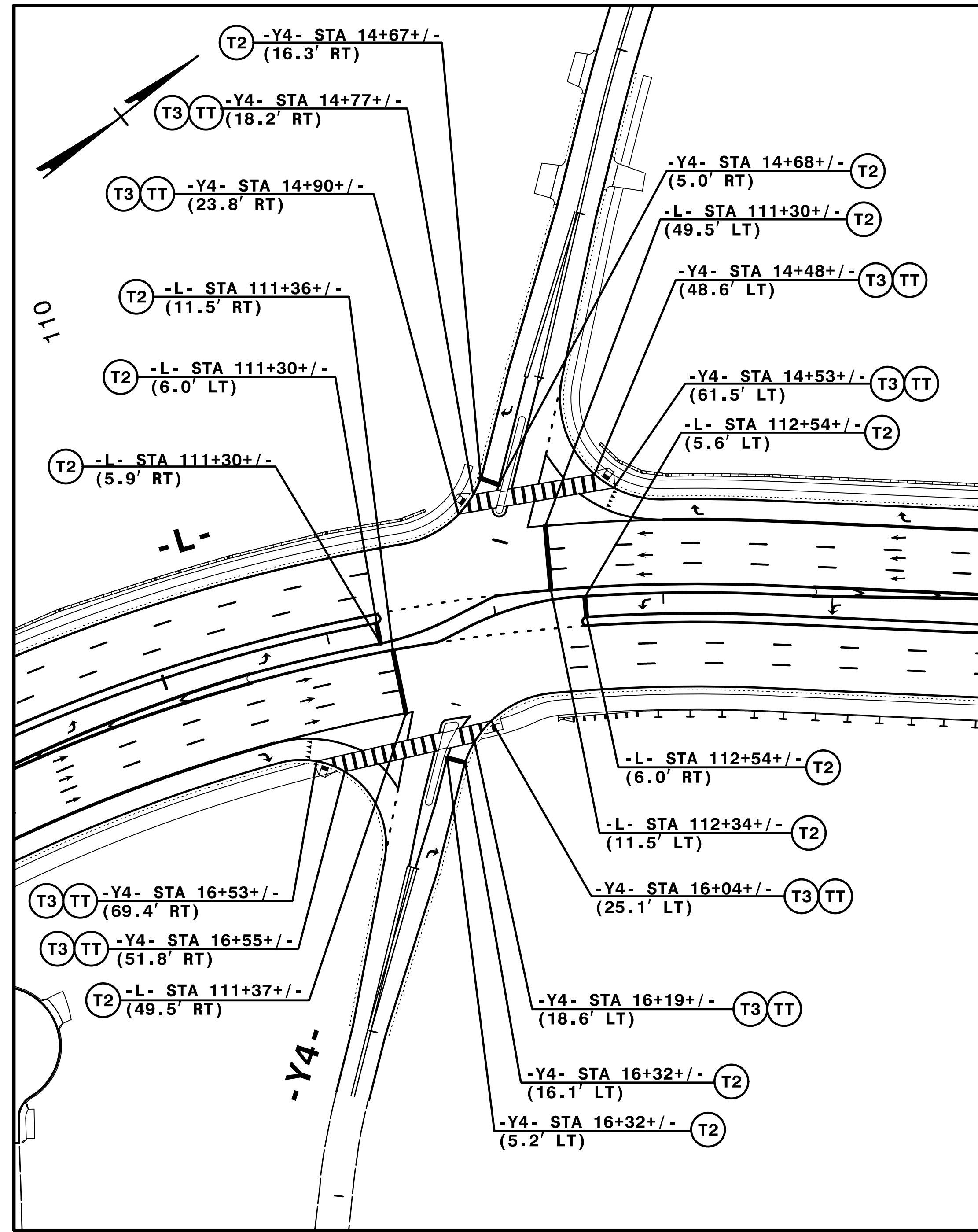

-L- (NC---) / -Y5- (TORCHWOOD BLVD)

SEE SHEET PMP-2 FOR CROSSWALK DETAILS

SEE SHEET PMP-12 FOR ADDITIONAL STATIONING

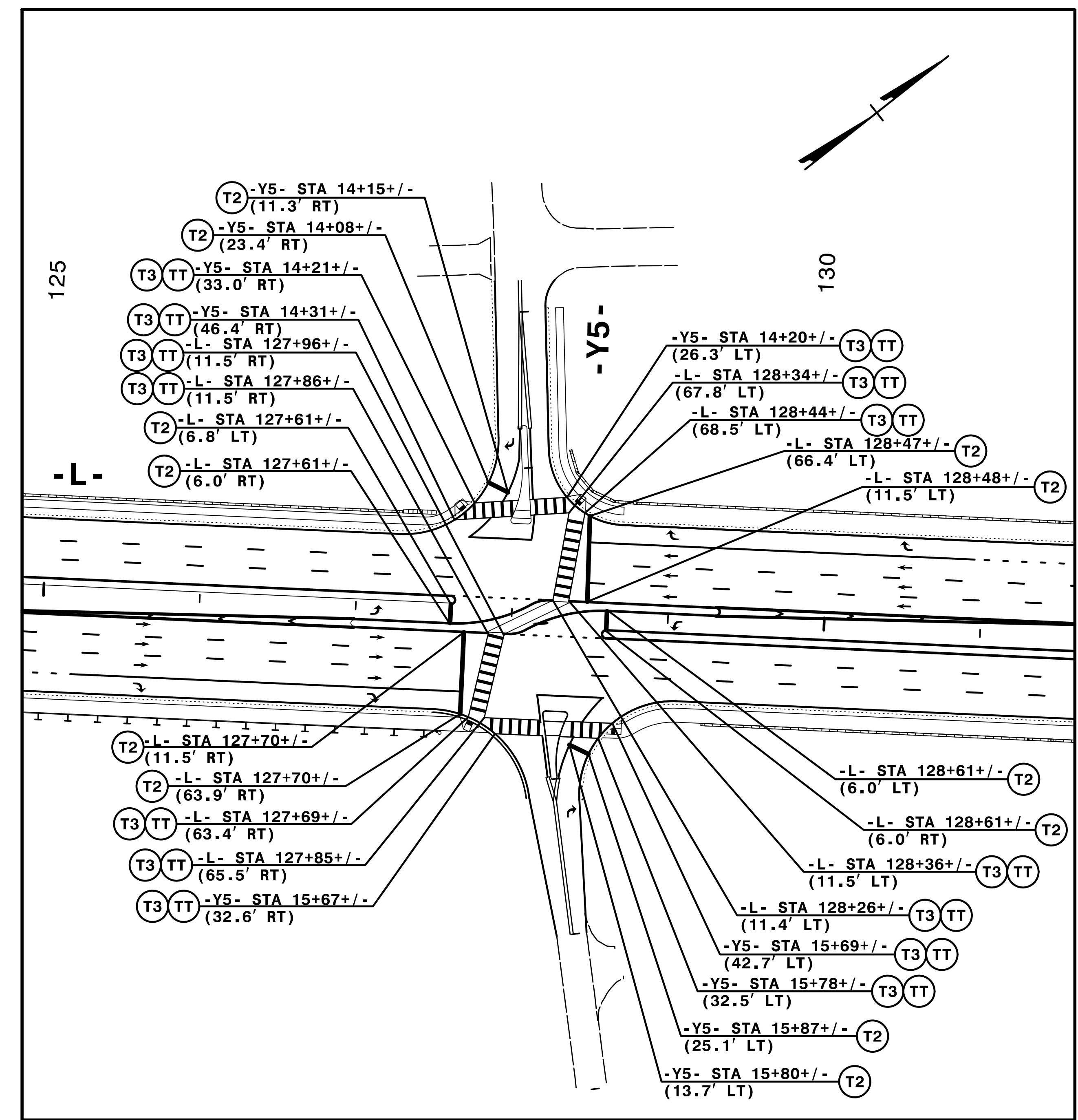

7/5/2017
PMP-U4751_PMP_38.dgn
HNTB

HNTB HNTB NORTH CAROLINA, P.C.
343 E. Six Forks Road, Suite 200
Raleigh, North Carolina 27609
NC License No: C-1554
(919) 546-8997

**PAVEMENT MARKING DETAIL
STOP BAR AND CROSSWALK
LOCATIONS**

TIP NO. U-4751	SHEET NO. PMP-39
APPROVED: <i>Andrew D. Klinkosiek</i> E3078FB4586E44B	
DATE: 7/5/2017	
	
DOCUMENT NOT CONSIDERED FINAL UNLESS ALL SIGNATURES COMPLETED	

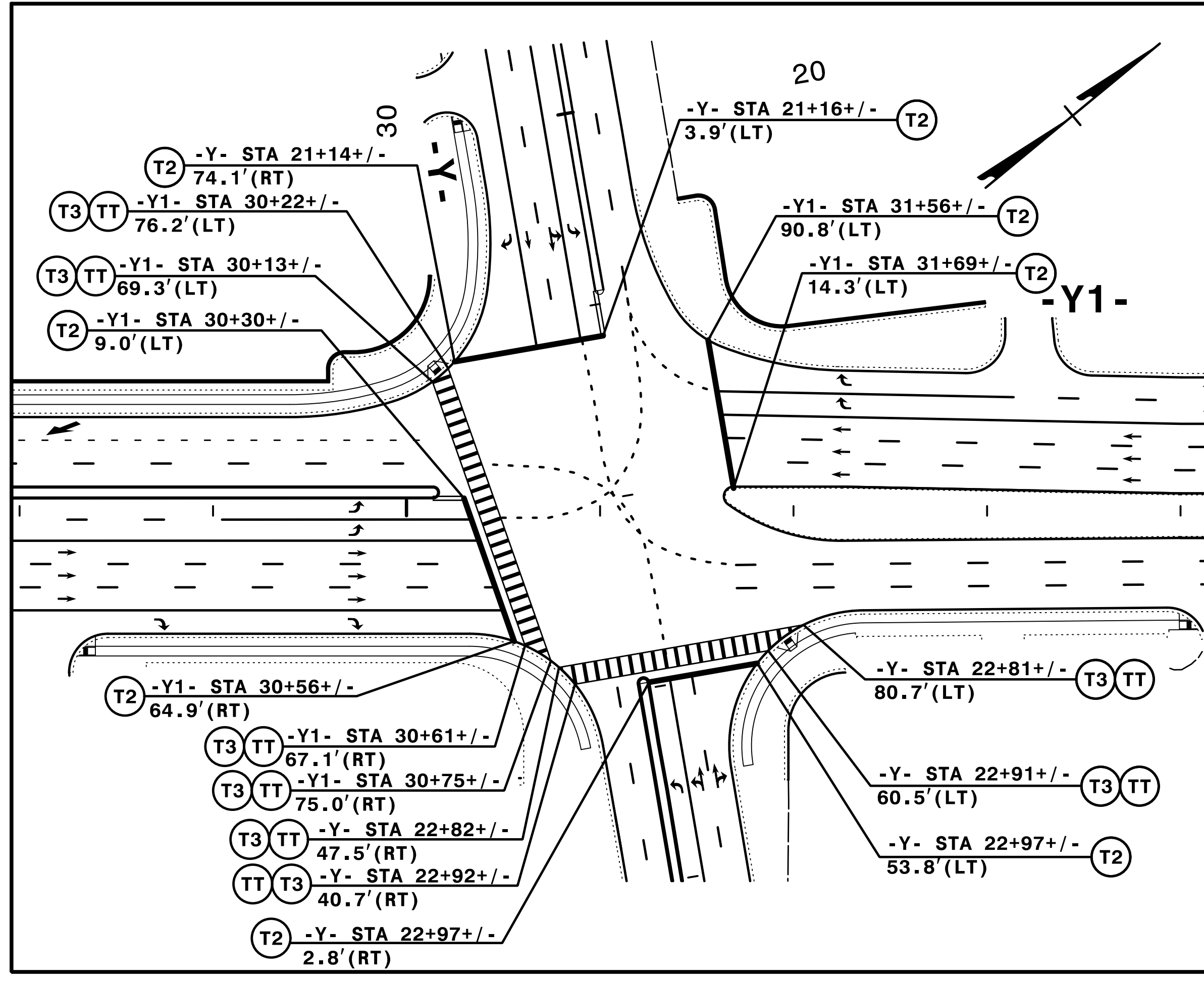

-Y1- (US 17 BUS) / -Y- (SR 2048)

SEE SHEET PMP-2 FOR CROSSWALK DETAILS

SEE SHEET PMP-21 FOR ADDITIONAL STATIONING

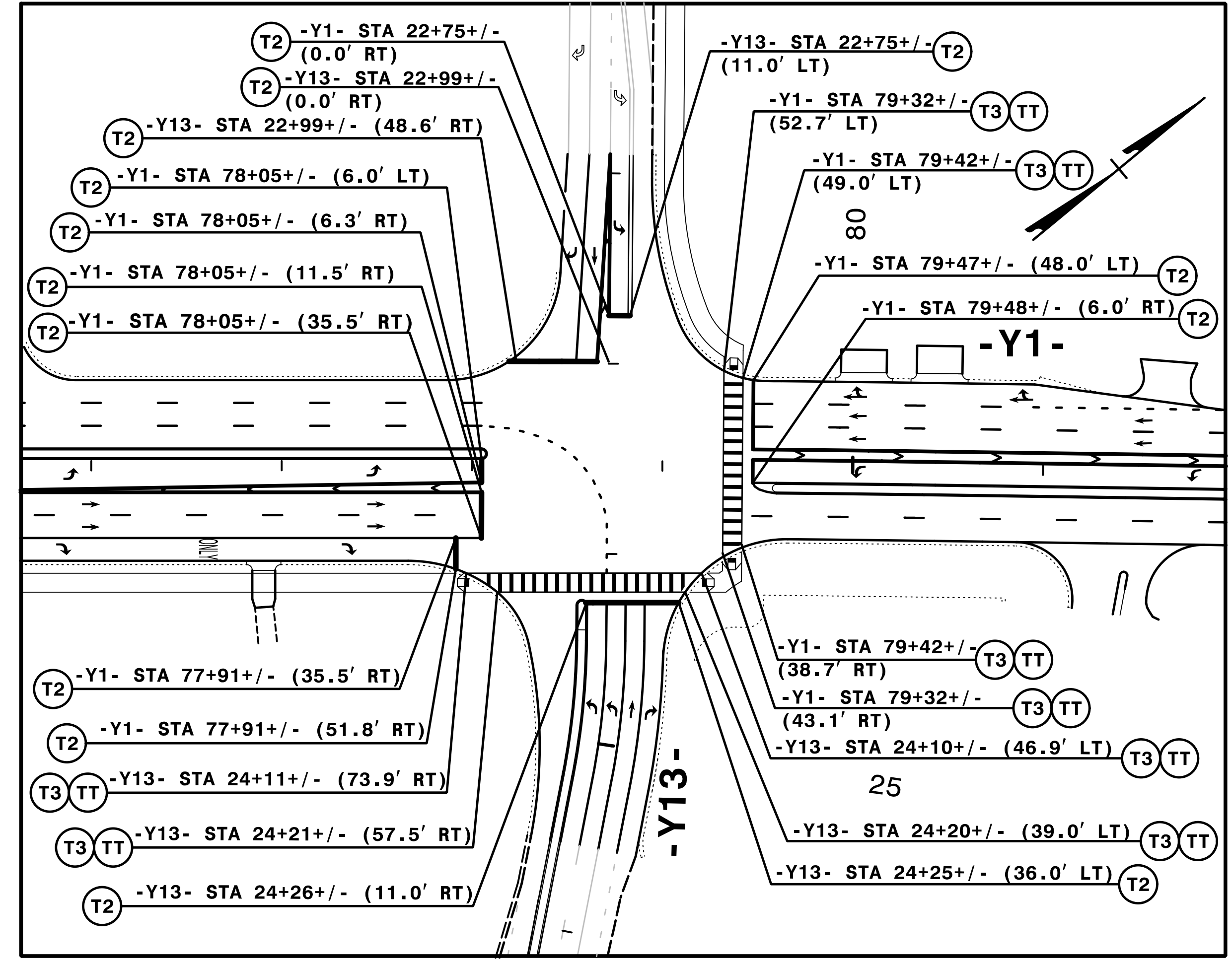

-Y1- (US 17) / -Y13- (LENDIRE RD)

SEE SHEET PMP-2 FOR CROSSWALK DETAILS

SEE SHEET PMP-25 FOR ADDITIONAL STATIONING

7/5/2017
PMP-U4751_PMP_39.dgn
HNTB

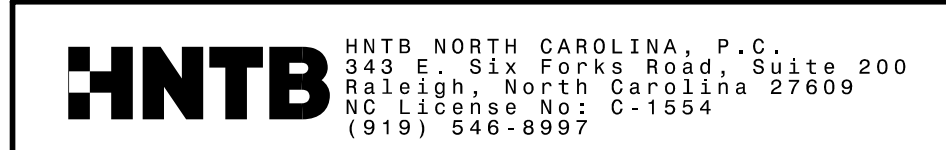

**PAVEMENT MARKING DETAIL
STOP BAR AND CROSSWALK
LOCATIONS**