

ELEVATION

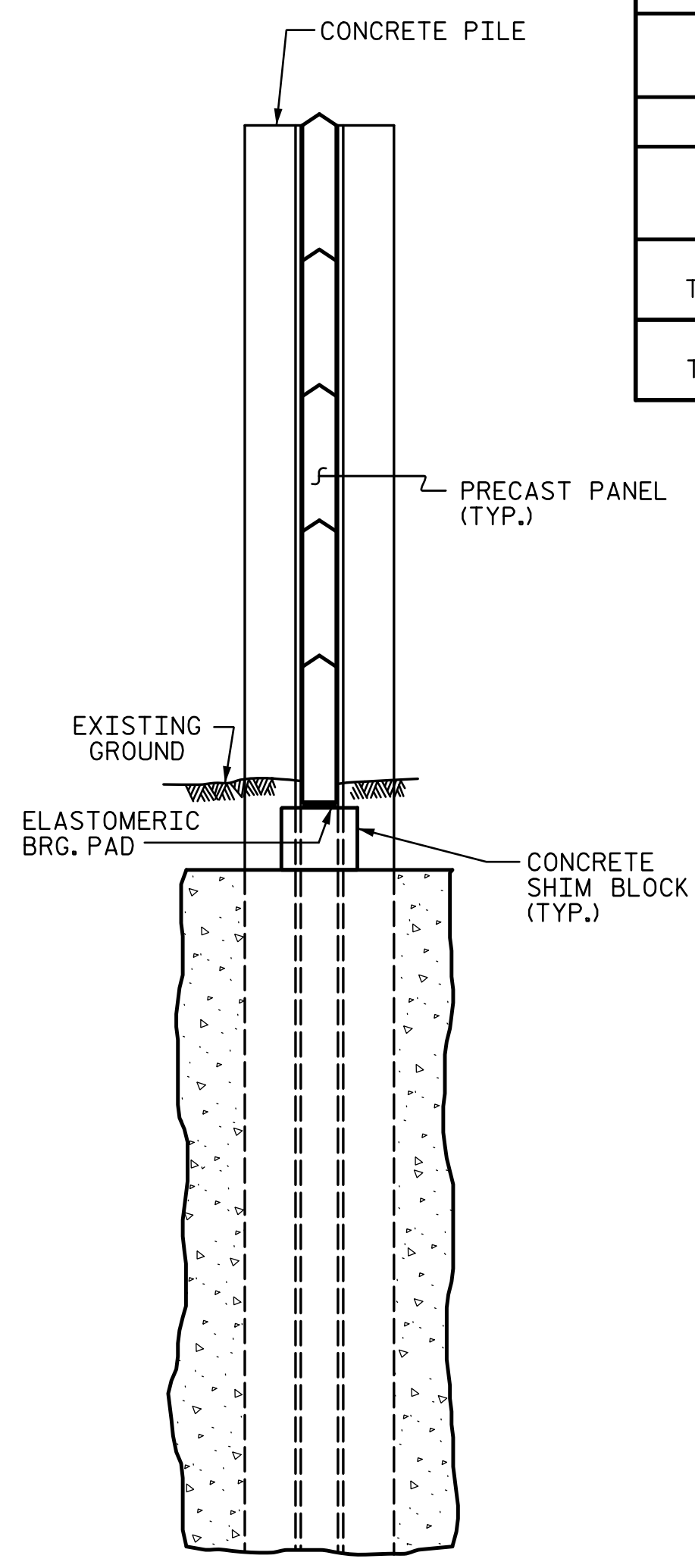

SECTION A-A

PILE EXCAVATION DEPTHS "D"			
3'-0" Ø HOLE			
WALL -NW1B- (STA. 10+00 TO 14+10 -NW1B-)			
STATION	MAX WALL HEIGHT	PILE SPACING	SHAFT DEPTH
STA. 17+56.65 -L- TO STA. 17+66.65 -L-	8'-0"	10'-0"	11'-0"
STA. 17+76.65 -L- TO STA. 21+38.59 -L-	10'-0"	15'-0"	13'-0"

NOTES:

- FOR SOUND BARRIER WALL, SEE SPECIAL PROVISIONS.
- CONSTRUCT SOUND BARRIER WALL TO LINES AND GRADES SHOWN ON THE ROADWAY PLANS.
- PROVIDE PANELS WITH A FLAT BOTTOM.
- VERIFY THE LOCATION OF UNDERGROUND UTILITIES BEFORE DRILLING HOLES TO ENSURE SUFFICIENT CLEARANCE IS AVAILABLE.
- ADJUST PILE EXCAVATION ELEVATIONS TO MAINTAIN 6" MINIMUM EMBEDMENT OF THE BOTTOM PANEL.
- USE CLASS AA FOR PANELS AND CLASS A CONCRETE PILE EXCAVATION BACKFILL, IN ACCORDANCE WITH ARTICLE 1000-4 OF THE STANDARD SPECIFICATIONS.
- FOR SOUND BARRIER WALL STATIONS, OFFSETS, AND WALL ENVELOPE, SEE ROADWAY PLANS.
- PLACE 1" Ø BACKER RODS FULL HEIGHT ON EACH SIDE OF THE PRECAST PANELS. SET AND SEAL THE BACKER ROD IN PLACE WITH SEALANT THAT CONFORMS WITH ARTICLE 1028-3 OF THE STANDARD SPECIFICATIONS.
- FOR SUBMITTAL OF WORKING DRAWINGS, SEE SPECIAL PROVISIONS.
- FOR FALSEWORK AND FORMWORK, SEE SPECIAL PROVISIONS.
- FOR ELASTOMERIC BEARING DETAILS, SEE "SOUND BARRIER WALL DETAILS" SHEET 1 OF 3.
- FOR CONCRETE SHIM BLOCK DETAILS, SEE "SOUND BARRIER WALL DETAILS" SHEET 1 OF 3.
- FOR PRECAST PANEL DETAILS, SEE "SOUND BARRIER WALL DETAILS" SHEET 1 OF 3.
- FOR CONCRETE PILE DETAILS, SEE "SOUND BARRIER WALL DETAILS" SHEETS 1 & 2 OF 3.
- AT THE CONTRACTOR'S OPTION, USE CONTINUOUS FLIGHT AUGER PILES IN LIEU OF PILE EXCAVATION FOR SOUND BARRIER WALL FOUNDATION. SEE "CONTINUOUS FLIGHT AUGER PILES FOR SOUND BARRIER WALLS" SPECIAL PROVISION.
- THE ARCHITECTURAL CONCRETE SURFACE TREATMENT SHALL MATCH THE APPEARANCE (STONE SIZE AND SHAPE, STONE TEXTURE, PATTERN AND RELIEF) OF NATURAL STONE TO RESEMBLE A DRY STACKED STONE PATTERN WITH FEDERAL STANDARD 595 COLOR # FS30450 STAIN.

EXPOSURE CATEGORY D - PILE REINFORCING STEEL

DESIGN WIND PRESSURE = 62 PSF (0' < H ≤ 14'); 71 PSF (14' < H ≤ 25')							
PILE TYPE I				PILE TYPE III			
PILE SPACING	MAXIMUM WALL HEIGHT (H)	VERTICAL REINFORCING STEEL	TIES	PILE SPACING	MAXIMUM WALL HEIGHT (H)	VERTICAL REINFORCING STEEL	TIES
10'-0"	H ≤ 15'	4 - #8 EA. FACE	#3 @ 11" CTS.	10'-0"	H ≤ 15'	3 - #9 SHORT FACE 4 - #9 LONG FACE	#3 @ 11" CTS.
15'-0"	H ≤ 15'	4 - #8 EA. FACE	#3 @ 11" CTS.	15'-0"	H ≤ 15'	3 - #9 SHORT FACE 4 - #9 LONG FACE	#3 @ 11" CTS.
PILE TYPE II				PILE TYPE III ALT.			
PILE SPACING	MAXIMUM WALL HEIGHT (H)	VERTICAL REINFORCING STEEL	TIES	PILE SPACING	MAXIMUM WALL HEIGHT (H)	VERTICAL REINFORCING STEEL	TIES
10'-0"	H ≤ 15'	4 - #6 EA. FACE	#3 @ 11" CTS.	10'-0"	H ≤ 15'	3 - #9 SHORT FACE 4 - #9 LONG FACE	#3 @ 11" CTS.
15'-0"	H ≤ 15'	4 - #6 EA. FACE	#3 @ 11" CTS.	15'-0"	H ≤ 15'	3 - #9 SHORT FACE 4 - #9 LONG FACE	#3 @ 11" CTS.

BILL OF MATERIAL -NW1B-

SOUND BARRIER WALL	S.F. 3,653
ARCHITECTURAL SURFACE TREATMENT	S.F. 2,900
QUANTITIES PROVIDED ARE APPROXIMATE AND ARE FOR BID PURPOSES ONLY.	

PROJECT NO. U-4751  
 NEW HANOVER COUNTY  
 STATION: 17+56.65 -L- = 10+00.00 -NW1B-

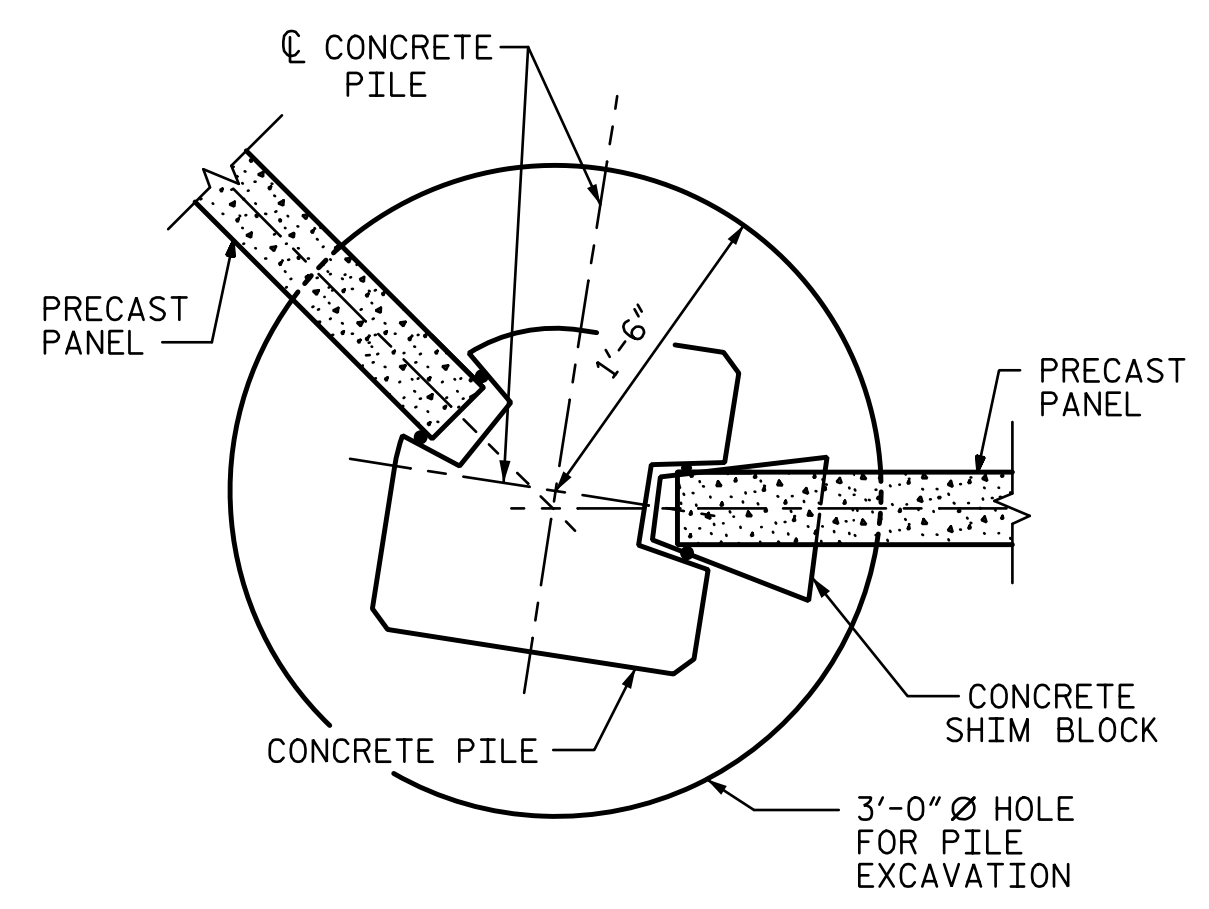

15° TO 45° TURNS (PILE TYPE III)  
 TYPICAL WALL TURN DETAILS

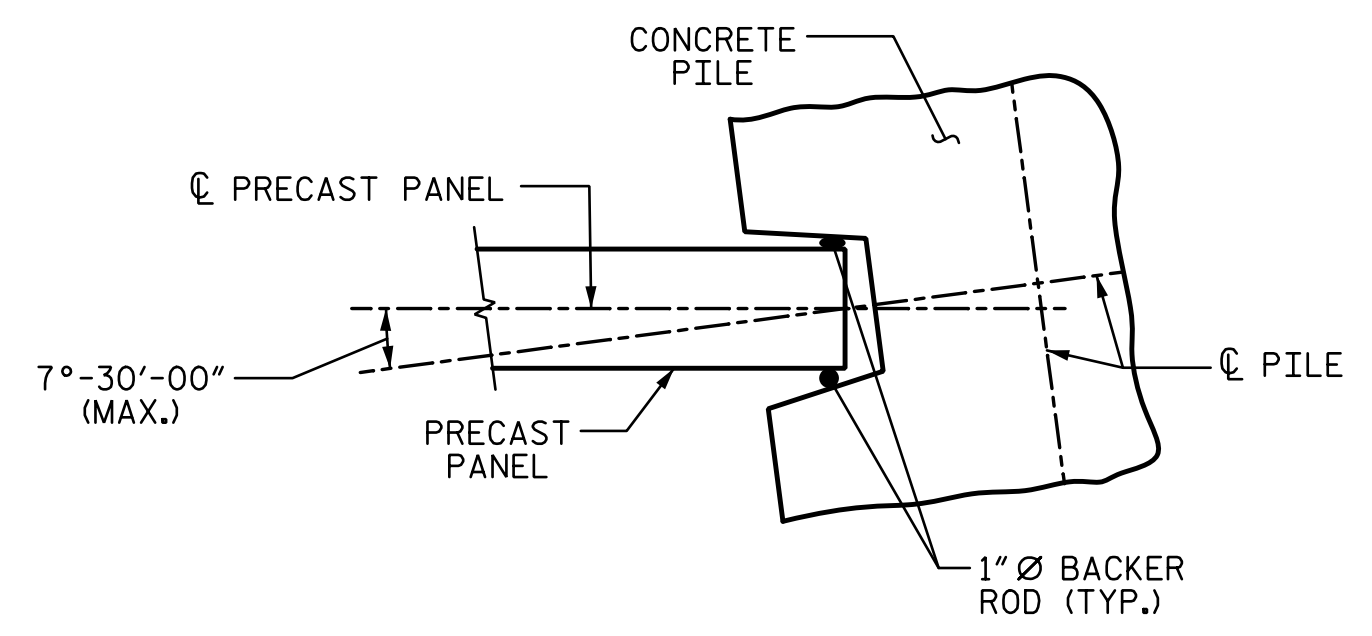

PILE ROTATION LIMIT FOR WALL TURN

(ROTATE THE CONCRETE PILE ±7°-30'-00" MAX. TO ACCOMMODATE WALL TURN.)

DOCUMENT NOT CONSIDERED FINAL UNLESS ALL SIGNATURES COMPLETED

STATE OF NORTH CAROLINA  
 DEPARTMENT OF TRANSPORTATION  
 RALEIGH

**SOUND BARRIER WALL  
 NO. -NW1B-**

REVISIONS						SHEET NO.
NO.	BY:	DATE:	NO.	BY:	DATE:	NW-2
1			3			TOTAL SHEETS
2			4			17

STV ENGINEERS, INC. 900 West Trade St., Suite 715 Charlotte, NC 28202 NC License Number F-5991

R:\No\seawalls\NW\420\_00\U4751\_SMU\_001\_6400IB.dgn 3:02:16 PM 8/17/2017

DRAWN BY: MBC DATE: 5-17  
 CHECKED BY: NML DATE: 5-17  
 DESIGN ENGINEER OF RECORD: J. DICHAK DATE: 5-17