

PARTIAL TYPICAL SECTION AT INTERMEDIATE DIAPHRAGM

PARTIAL TYPICAL SECTION AT END DIAPHRAGM

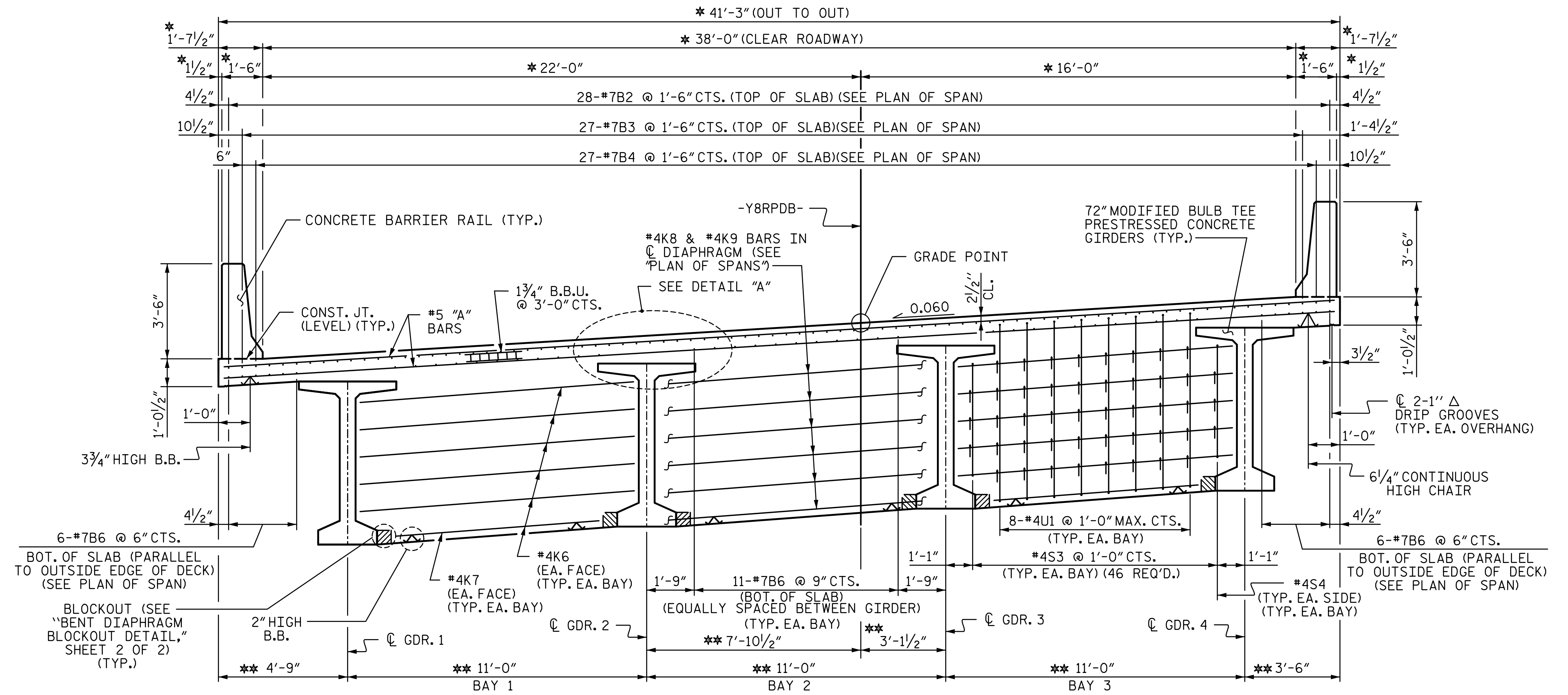

TYPICAL SECTION @ BENT DIAPHRAGM

NOTES:

PROVIDE 1/4" HIGH BEAM BOLSTERS UPPER AT 4'-0" CTS. ATOP THE METAL STAY-IN-PLACE FORMS TO SUPPORT THE BOTTOM MAT OF "A" BARS. WHEN USING REMOVABLE FORMS, PROVIDE CONTINUOUS HIGH CHAIRS FOR METAL DECK (C.H.C.M.) @ 4'-0" CTS. WITH A HEIGHT TO SUPPORT THE BOTTOM MAT OF "A" BARS A CLEAR DISTANCE OF 2 1/2" ABOVE THE TOP OF THE REMOVABLE FORM.

LONGITUDINAL STEEL MAY BE SHIFTED SLIGHTLY, AS NECESSARY, TO AVOID INTERFERENCE WITH STIRRUPS IN PRESTRESSED CONCRETE GIRDERS.

PREVIOUSLY CAST CONCRETE IN A CONTINUOUS UNIT SHALL HAVE ATTAINED A MINIMUM COMPRESSIVE STRENGTH OF 3,000 PSI BEFORE ADDITIONAL CONCRETE IS CAST IN THE UNIT.

FOR INTERMEDIATE DIAPHRAGM DETAILS, SEE SHEET "INTERMEDIATE STEEL DIAPHRAGMS FOR 72" MODIFIED BULB TEE PRESTRESSED CONCRETE GIRDERS".

FOR BARRIER RAIL DETAILS, SEE "CONCRETE BARRIER RAIL SHEET".

HEIGHT OF BEAM BOLSTER AND CONTINUOUS HIGH CHAIR IS CALCULATED @ C BENT. CONTRACTOR SHALL ADJUST HEIGHTS, AS NECESSARY TO MAINTAIN PROPER CLEARANCE, DUE TO GIRDER CAMBER.

FOR EXPANSION JOINT SEALS, SEE SPECIAL PROVISIONS.

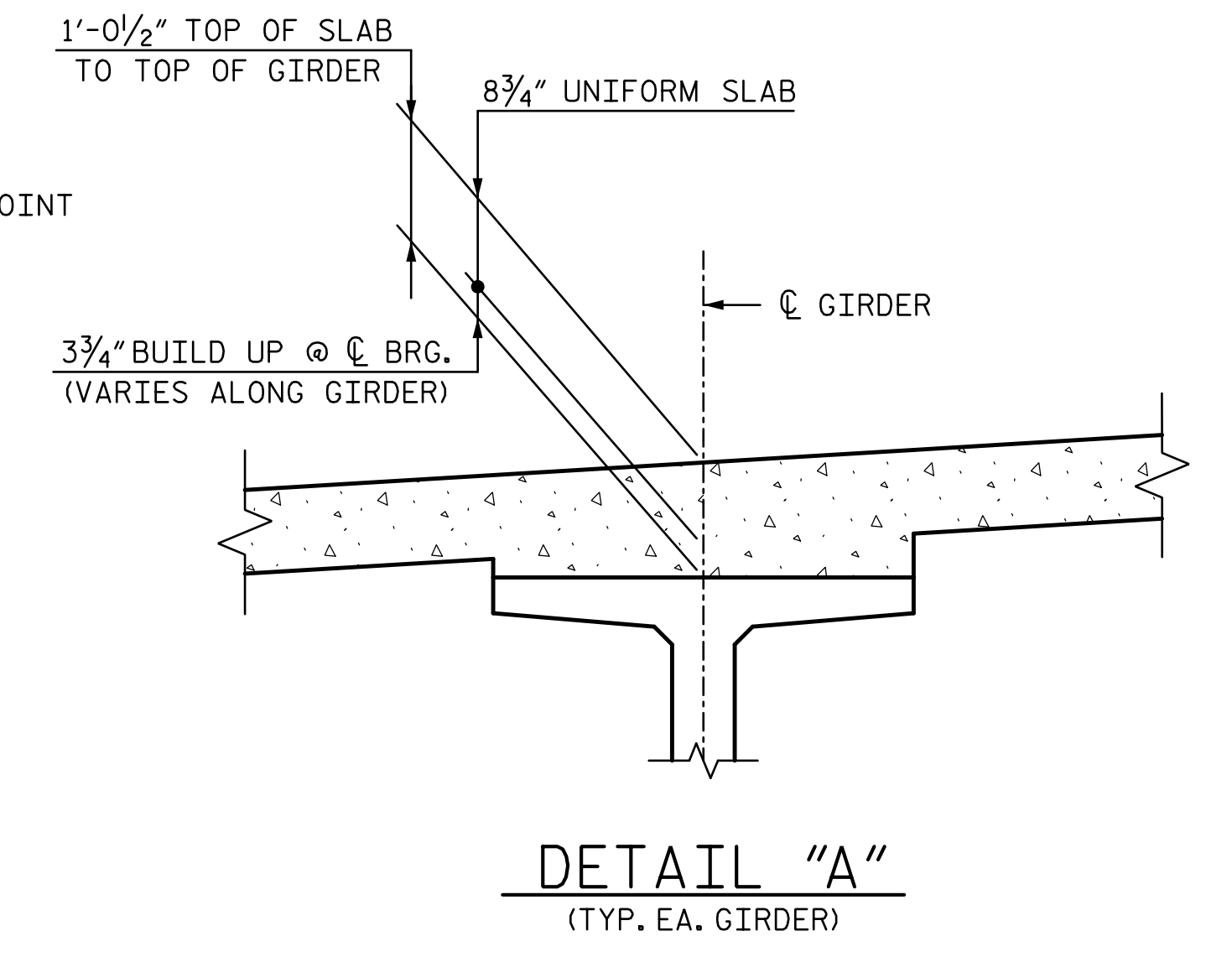

* RADIAL DIMENSION
** RADIAL DIMENSION THRU WORKPOINT

PROJECT NO. U-4751
NEW HANOVER COUNTY
 STATION: 35+12.05 -Y8RPDB-
 SHEET 1 OF 2

DOCUMENT NOT CONSIDERED FINAL UNLESS ALL SIGNATURES COMPLETED		STATE OF NORTH CAROLINA DEPARTMENT OF TRANSPORTATION RALEIGH		SHEET NO. S4-6 TOTAL SHEETS 36			
		SUPERSTRUCTURE TYPICAL SECTION					
		REVISIONS					
		NO.	BY:	DATE:	NO.	BY:	DATE:
		1			3		
		2			4		

r:\404_OIL\14751_SMU_TSO1_006_640204.dgn
 6/30/2017 13:09:44
 ttownsend

DRAWN BY: MBC DATE: 3-17
 CHECKED BY: TRL DATE: 4-17
 DESIGN ENGINEER OF RECORD: T. LAWS DATE: 5-17