

STATE OF NORTH CAROLINA  
DEPARTMENT OF TRANSPORTATION  
RALEIGH, N.C.

PROPOSAL

DATE AND TIME OF BID OPENING: **OCTOBER 17, 2017 AT 2:00 PM**

CONTRACT ID C203979  
WBS 34839.3.GV6

FEDERAL-AID NO. NHP-0918(062)  
COUNTY FORSYTH  
T.I.P. NO. U-2579C  
MILES 1.989  
ROUTE NO.  
LOCATION WINSTON-SALEM NORTHERN BELTWAY (EASTERN SECTION) FROM US-311  
TO US-158 (FUTURE I-74)  
TYPE OF WORK WIDEN, GRADING, PAVING, DRAINAGE, SIGNING, SIGNALS, & STRS.

**NOTICE:**

ALL BIDDERS SHALL COMPLY WITH ALL APPLICABLE LAWS REGULATING THE PRACTICE OF GENERAL CONTRACTING AS CONTAINED IN CHAPTER 87 OF THE GENERAL STATUTES OF NORTH CAROLINA WHICH REQUIRES THE BIDDER TO BE LICENSED BY THE N.C. LICENSING BOARD FOR CONTRACTORS WHEN BIDDING ON ANY NON-FEDERAL AID PROJECT WHERE THE BID IS \$30,000 OR MORE, EXCEPT FOR CERTAIN SPECIALTY WORK AS DETERMINED BY THE LICENSING BOARD. BIDDERS SHALL ALSO COMPLY WITH ALL OTHER APPLICABLE LAWS REGULATING THE PRACTICES OF ELECTRICAL, PLUMBING, HEATING AND AIR CONDITIONING AND REFRIGERATION CONTRACTING AS CONTAINED IN CHAPTER 87 OF THE GENERAL STATUTES OF NORTH CAROLINA. NOTWITHSTANDING THESE LIMITATIONS ON BIDDING, THE BIDDER WHO IS AWARDED ANY FEDERAL - AID FUNDED PROJECT SHALL COMPLY WITH CHAPTER 87 OF THE GENERAL STATUTES OF NORTH CAROLINA FOR LICENSING REQUIREMENTS WITHIN 60 CALENDAR DAYS OF BID OPENING.

**BIDS WILL BE RECEIVED AS SHOWN BELOW:**

**THIS IS A ROADWAY & STRUCTURE PROPOSAL**

**5% BID BOND OR BID DEPOSIT REQUIRED**

---

**PROPOSAL FOR THE CONSTRUCTION OF  
CONTRACT No. C203979 IN FORSYTH COUNTY, NORTH CAROLINA**

Date \_\_\_\_\_ 20 \_\_\_\_\_

**DEPARTMENT OF TRANSPORTATION,  
RALEIGH, NORTH CAROLINA**

The Bidder has carefully examined the location of the proposed work to be known as Contract No. C203979 has carefully examined the plans and specifications, which are acknowledged to be part of the proposal, the special provisions, the proposal, the form of contract, and the forms of contract payment bond and contract performance bond; and thoroughly understands the stipulations, requirements and provisions. The undersigned bidder agrees to bound upon his execution of the bid and subsequent award to him by the Board of Transportation in accordance with this proposal to provide the necessary contract payment bond and contract performance bond within fourteen days after the written notice of award is received by him. The undersigned Bidder further agrees to provide all necessary machinery, tools, labor, and other means of construction; and to do all the work and to furnish all materials, except as otherwise noted, necessary to perform and complete the said contract in accordance with *the 2012 Standard Specifications for Roads and Structures* by the dates(s) specified in the Project Special Provisions and in accordance with the requirements of the Engineer, and at the unit or lump sum prices, as the case may be, for the various items given on the sheets contained herein.

The Bidder shall provide and furnish all the materials, machinery, implements, appliances and tools, and perform the work and required labor to construct and complete State Highway Contract No. C203979 in **Forsyth County**, for the unit or lump sum prices, as the case may be, bid by the Bidder in his bid and according to the proposal, plans, and specifications prepared by said Department, which proposal, plans, and specifications show the details covering this project, and hereby become a part of this contract.

The published volume entitled *North Carolina Department of Transportation, Raleigh, Standard Specifications for Roads and Structures, January 2012* with all amendments and supplements thereto, is by reference incorporated into and made a part of this contract; that, except as herein modified, all the construction and work included in this contract is to be done in accordance with the specifications contained in said volume, and amendments and supplements thereto, under the direction of the Engineer.

If the proposal is accepted and the award is made, the contract is valid only when signed either by the Contract Officer or such other person as may be designated by the Secretary to sign for the Department of Transportation. The conditions and provisions herein cannot be changed except over the signature of the said Contract Officer.

The quantities shown in the itemized proposal for the project are considered to be approximate only and are given as the basis for comparison of bids. The Department of Transportation may increase or decrease the quantity of any item or portion of the work as may be deemed necessary or expedient.

An increase or decrease in the quantity of an item will not be regarded as sufficient ground for an increase or decrease in the unit prices, nor in the time allowed for the completion of the work, except as provided for the contract.

Accompanying this bid is a bid bond secured by a corporate surety, or certified check payable to the order of the Department of Transportation, for five percent of the total bid price, which deposit is to be forfeited as liquidated damages in case this bid is accepted and the Bidder shall fail to provide the required payment and performance bonds with the Department of Transportation, under the condition of this proposal, within 14 calendar days after the written notice of award is received by him, as provided in the *Standard Specifications*; otherwise said deposit will be returned to the Bidder.



*State Contract Officer*

DocuSigned by:  
*Ronald Elton Davenport, Jr.* 8/21/2017  
F81B6038A47A442...

**TABLE OF CONTENTS**

**COVER SHEET  
PROPOSAL SHEET**

**PROJECT SPECIAL PROVISIONS**

CONTRACT TIME AND LIQUIDATED DAMAGES: ..... G-1  
INTERMEDIATE CONTRACT TIME NUMBER 1 AND LIQUIDATED DAMAGES: ..... G-1  
INTERMEDIATE CONTRACT TIME NUMBER 2 AND LIQUIDATED DAMAGES: ..... G-2  
INTERMEDIATE CONTRACT TIME NUMBER 3 AND LIQUIDATED DAMAGES: ..... G-3  
INTERMEDIATE CONTRACT TIME NUMBER 4 AND LIQUIDATED DAMAGES: ..... G-3  
INTERMEDIATE CONTRACT TIME NUMBER 5 AND LIQUIDATED DAMAGES: ..... G-3  
PERMANENT VEGETATION ESTABLISHMENT:..... G-4  
DELAY IN RIGHT OF ENTRY: ..... G-5  
DELAY IN RIGHT OF WAY: ..... G-5  
MAJOR CONTRACT ITEMS: ..... G-6  
SPECIALTY ITEMS: ..... G-6  
FUEL PRICE ADJUSTMENT: ..... G-6  
PAYOUT SCHEDULE: ..... G-7  
SCHEDULE OF ESTIMATED COMPLETION PROGRESS:..... G-7  
DISADVANTAGED BUSINESS ENTERPRISE: ..... G-8  
CERTIFICATION FOR FEDERAL-AID CONTRACTS: ..... G-20  
CONTRACTOR'S LICENSE REQUIREMENTS: ..... G-21  
U.S. DEPARTMENT OF TRANSPORTATION HOTLINE: ..... G-21  
CARGO PREFERENCE ACT: ..... G-22  
SUBSURFACE INFORMATION:..... G-22  
LOCATING EXISTING UNDERGROUND UTILITIES:..... G-22  
VALUE ENGINEERING PROPOSAL: ..... G-22  
RESOURCE CONSERVATION AND ENV. SUSTAINABLE PRACTICES:..... G-23  
DOMESTIC STEEL: ..... G-24  
MAINTENANCE OF THE PROJECT: ..... G-24  
COOPERATION BETWEEN CONTRACTORS:..... G-25  
BID DOCUMENTATION: ..... G-25  
TWELVE MONTH GUARANTEE: ..... G-29  
IRAN DIVESTMENT ACT: ..... G-29  
GIFTS FROM VENDORS AND CONTRACTORS: ..... G-30  
LIABILITY INSURANCE:..... G-30  
EROSION AND SEDIMENT CONTROL/STORMWATER CERTIFICATION:..... G-31  
PROCEDURE FOR MONITORING BORROW PIT DISCHARGE:..... G-36  
EMPLOYMENT:..... G-37  
STATE HIGHWAY ADMINISTRATOR TITLE CHANGE:..... G-38  
SUBLETTING OF CONTRACT: ..... G-38

ROADWAY ..... R-1

**STANDARD SPECIAL PROVISIONS**

AVAILABILITY FUNDS – TERMINATION OF CONTRACTS ..... SSP-1

NCDOT GENERAL SEED SPECIFICATION FOR SEED QUALITY ..... SSP-2  
 ERRATA..... SSP-5  
 PLANT AND PEST QUARANTINES ..... SSP-7  
 AWARD OF CONTRACT..... SSP-8  
 MINORITY AND FEMALE EMPLOYMENT REQUIREMENTS ..... SSP-13  
 REQUIRED CONTRACT PROVISIONS FEDERAL-AID CONST. CONTRACTS ..... SSP-16  
 ON-THE-JOB TRAINING ..... SSP-25  
 NCDENR NAME CHANGE..... SSP-28  
 MINIMUM WAGES ..... SSP-29

**UNIT PROJECT SPECIAL PROVISIONS**

GEOTECHNICAL.....GT-0.1  
 SIGNING .....SN-1  
 TRAFFIC CONTROL .....TC-1  
 UTILITY CONSTRUCTION .....UC-1  
 UTILITY BY OTHERS.....UBO-1  
 EROSION CONTROL .....EC-1  
 TRAFFIC SIGNALS .....TS-1  
 ITS.....ITS-1  
 RAILROAD INSURANCE (Roadway) .....RI-1  
 STRUCTURE / CULVERTS.....ST-1

**PERMITS** .....P-1

**PROPOSAL ITEM SHEET**

ITEM SHEET(S) (TAN SHEETS)



**PROJECT SPECIAL PROVISIONS****GENERAL****CONTRACT TIME AND LIQUIDATED DAMAGES:**

(8-15-00) (Rev. 12-18-07)

108

SP1 G07 A

The date of availability for this contract is **November 27, 2017**, except the portion of the project from Sta. 373+00 -L- to Sta. 402+00 -L- will not be available before January 1<sup>st</sup> 2018 and except that work in jurisdictional waters and wetlands shall not begin until a meeting between the DOT, Regulatory Agencies, and the Contractor is held as stipulated in the permits contained elsewhere in this proposal. This delay in availability has been considered in determining the contract time for this project.

The completion date for this contract is **November 28, 2021**.

Except where otherwise provided by the contract, observation periods required by the contract will not be a part of the work to be completed by the completion date and/or intermediate contract times stated in the contract. The acceptable completion of the observation periods that extend beyond the final completion date shall be a part of the work covered by the performance and payment bonds.

The liquidated damages for this contract are **Two Hundred Dollars (\$ 200.00)** per calendar day. These liquidated damages will not be cumulative with any liquidated damages which may become chargeable under Intermediate Contract Time Number 1.

**INTERMEDIATE CONTRACT TIME NUMBER 1 AND LIQUIDATED DAMAGES:**

(7-1-95) (Rev. 2-21-12)

108

SP1 G13 A

Except for that work required under the Project Special Provisions entitled *Planting, Reforestation* and/or *Permanent Vegetation Establishment*, included elsewhere in this proposal, the Contractor will be required to complete all work included in this contract and shall place and maintain traffic on same.

The date of availability for this intermediate contract time is **November 27, 2017**.

The completion date for this intermediate contract time is **June 1, 2021**.

The liquidated damages for this intermediate contract time are **Four Thousand Dollars (\$ 4,000.00)** per calendar day.

Upon apparent completion of all the work required to be completed by this intermediate date, a final inspection will be held in accordance with Article 105-17 and upon acceptance, the Department will assume responsibility for the maintenance of all work except *Planting, Reforestation* and/or *Permanent Vegetation Establishment*. The Contractor will be responsible for and shall make corrections of all damages to the completed roadway caused by his planting operations, whether occurring prior to or after placing traffic through the project.

**INTERMEDIATE CONTRACT TIME NUMBER 2 AND LIQUIDATED DAMAGES:**

(2-20-07)

108

SP1 G14 A

The Contractor shall complete the required work of installing, maintaining, and removing the traffic control devices for lane closures and restoring traffic to the existing traffic pattern. The Contractor shall not close or narrow a lane of traffic on **US 311 (-Y1-) and Williston Road (-Y2-)** during the following time restrictions:

**DAY AND TIME RESTRICTIONS****WHEN SCHOOL IS IN SESSION****from 6:00 AM to 9:00 AM****And****from 3:00 PM to 6:00 PM**

In addition, the Contractor shall not close or narrow a lane of traffic on **US 311 (-Y1-) and Williston Road (-Y2-)** detain and/or alter the traffic flow on or during holidays, holiday weekends, special events, or any other time when traffic is unusually heavy, including the following schedules:

**HOLIDAY AND HOLIDAY WEEKEND LANE CLOSURE RESTRICTIONS**

1. For **unexpected occurrence** that creates unusually high traffic volumes, as directed by the Engineer.
2. For **New Year's Day**, between the hours of **6:00 AM** December 31st and **6:00 PM** January 2nd. If New Year's Day is on a Friday, Saturday, Sunday or Monday, then until **6:00 PM** the following Tuesday.
3. For **Easter**, between the hours of **6:00 AM** Thursday and **6:00 PM** Monday.
4. For **Memorial Day**, between the hours of **6:00 AM** Friday and **6:00 PM** Tuesday.
5. For **Independence Day**, between the hours of **6:00 AM** the day before Independence Day and **6:00 PM** the day after Independence Day.  
  
If **Independence Day** is on a Friday, Saturday, Sunday or Monday, then between the hours of **6:00 AM** the Thursday before Independence Day and **6:00 PM** the Tuesday after Independence Day.
6. For **Labor Day**, between the hours of **6:00 AM** Friday and **6:00 PM** Tuesday.
7. For **Thanksgiving Day**, between the hours of **6:00 AM** Tuesday and **6:00 PM** Monday.
8. For **Christmas**, between the hours of **6:00 AM** the Friday before the week of Christmas Day and **6:00 PM** the following Tuesday after the week of Christmas Day.

Holidays and holiday weekends shall include New Year's, Easter, Memorial Day, Independence Day, Labor Day, Thanksgiving, and Christmas. The Contractor shall schedule his work so that lane closures will not be required during these periods, unless otherwise directed by the Engineer.

The time of availability for this intermediate contract work shall be the time the Contractor begins to install all traffic control devices for lane closures according to the time restrictions listed herein.

The completion time for this intermediate contract work shall be the time the Contractor is required to complete the removal of all traffic control devices for lane closures according to the time restrictions stated above and place traffic in the existing traffic pattern.

The liquidated damages are **Two Hundred and Fifty Dollars (\$ 250.00)** per fifteen (15) minute time period.

**INTERMEDIATE CONTRACT TIME NUMBER 3 AND LIQUIDATED DAMAGES:**

(2-20-07) (Rev. 6-18-13)

108

SP1 G14 H

The Contractor shall complete the work required of **Phase I, Step #3** as shown on Sheet **TMP- 3** and shall place and maintain traffic on same.

The date of availability for this intermediate contract time is the date the Contractor elects to begin the work.

The completion date for this intermediate contract time is the date which is **thirty (30)** consecutive calendar days after and including the date the Contractor begins this work.

The liquidated damages are **Two Thousand Five Hundred Dollars (\$ 2,500.00)** per calendar day.

**INTERMEDIATE CONTRACT TIME NUMBER 4 AND LIQUIDATED DAMAGES:**

(2-20-07) (Rev. 6-18-13)

108

SP1 G14 F

The Contractor shall complete the work required of **Phase III, Step #1A** as shown on Sheet **TMP-3** and shall place and maintain traffic on same.

The time of availability for this intermediate contract time is the **Friday at 6:00 PM** that the Contractor elects to begin the work.

The completion time for this intermediate contract time is the following **Monday at 6:00 AM** after the time of availability.

The liquidated damages are **Two Hundred and Fifty Dollars (\$ 250.00)** per fifteen (15) minute time period.

**INTERMEDIATE CONTRACT TIME NUMBER 5 AND LIQUIDATED DAMAGES:**

(2-20-07) (Rev. 6-18-13)

108

SP1 G14 F

The Contractor shall complete the work required of **Phase III, Step #1B** as shown on Sheet **TMP-3** and shall place and maintain traffic on same.

The time of availability for this intermediate contract time is the **Friday at 6:00 PM** that the Contractor elects to begin the work.

The completion time for this intermediate contract time is the following **Monday at 6:00 AM** after the time of availability.

The liquidated damages are **Two Hundred and Fifty Dollars (\$ 250.00)** per fifteen (15) minute time period.

**PERMANENT VEGETATION ESTABLISHMENT:**

(2-16-12) (Rev. 10-15-13)

104

SP1 G16

Establish a permanent stand of the vegetation mixture shown in the contract. During the period between initial vegetation planting and final project acceptance, perform all work necessary to establish permanent vegetation on all erodible areas within the project limits, as well as, in borrow and waste pits. This work shall include erosion control device maintenance and installation, repair seeding and mulching, supplemental seeding and mulching, mowing, and fertilizer topdressing, as directed. All work shall be performed in accordance with the applicable section of the *2012 Standard Specifications*. All work required for initial vegetation planting shall be performed as a part of the work necessary for the completion and acceptance of the Intermediate Contract Time (ICT). Between the time of ICT and Final Project acceptance, or otherwise referred to as the vegetation establishment period, the Department will be responsible for preparing the required National Pollutant Discharge Elimination System (NPDES) inspection records.

Once the Engineer has determined that the permanent vegetation establishment requirement has been achieved at an 80% vegetation density (the amount of established vegetation per given area to stabilize the soil) and no erodible areas exist within the project limits, the Contractor will be notified to remove the remaining erosion control devices that are no longer needed. The Contractor will be responsible for, and shall correct any areas disturbed by operations performed in permanent vegetation establishment and the removal of temporary erosion control measures, whether occurring prior to or after placing traffic on the project.

Payment for *Response for Erosion Control, Seeding and Mulching, Repair Seeding, Supplemental Seeding, Mowing, Fertilizer Topdressing, Silt Excavation, and Stone for Erosion Control* will be made at contract unit prices for the affected items. Work required that is not represented by contract line items will be paid in accordance with Articles 104-7 or 104-3 of the *2012 Standard Specifications*. No additional compensation will be made for maintenance and removal of temporary erosion control items.

**DELAY IN RIGHT OF ENTRY:**

(7-1-95) (Rev. 7-15-14)

108

SP1 G22

The Contractor will not be allowed right of entry to the following parcel(s) prior to the listed date(s) unless otherwise permitted by the Engineer.

<b><u>Parcel No.</u></b>	<b><u>Property Owner</u></b>	<b><u>Date</u></b>
1	Oak Grove Moravian Ch. Trustees	Unknown
2	MDC Investments	Unknown
5	Oak Grove Moravian Church	Unknown
9	Margaret H. Hoerner and Helen Hammock, et. Al	Unknown
10	The Chapman Family Trust	Unknown
11	Robert B. Stimpson, et. Al	Unknown
33	Melvin R. Caldwell Jr. & Sherie F. Caldwell	Unknown
38	Carl Miller Revocable Family Trust	Unknown
49	Dale C. & Cathy S. Vanhoy	Unknown
55	Sherrell D. & L. Whicker	9/11/2017
79	Ferrell Construction Co.	Unknown
81	Christopher R. Rothrock	Unknown
89	Micah W Wolfington	10/02/17
94	Linda R. Shaw	10/16/17
95	Mt. Pleasant Holiness Church	1/8/2018
96	Lutheran Home W S Prop.	10/16/17
97	Maryann B. Sweat	10/16/17
98	Shannon S. Maloney	10/16/17
99	Walter & Marilyn Sawyers	10/16/17

**DELAY IN RIGHT OF WAY:**

The Contractor shall take no action that will result in unnecessary inconvenience, disproportionate injury or any action coercive in nature to occupants of residences, businesses, farms, or non-profit organizations who have not yet moved from the right of way of the parcels below:

<b><u>Parcel No.</u></b>	<b><u>Property Owner</u></b>	<b><u>Estimated Vacating Date</u></b>
1	Oak Grove Moravian Ch. Trustees	Unknown
2	MDC Investments	Unknown
9	Margaret H. Hoerner and Helen Hammock, et. Al	Unknown
10	The Chapman Family Trust	Unknown
11	Robert B. Stimpson, et. Al	Unknown
33	Melvin R. Caldwell Jr. & Sherie F. Caldwell	Unknown
49	Dale C. & Cathy S. Vanhoy	Unknown
55	Sherrell D. & L. Whicker	08/11/17
79	Ferrell Construction Co.	Unknown
81	Christopher R. Rothrock	Unknown
95	Mt. Pleasant Holiness Church	12/08/17

**MAJOR CONTRACT ITEMS:**

(2-19-02)

104

SP1 G28

The following listed items are the major contract items for this contract (see Article 104-5 of the 2012 *Standard Specifications*):

<b>Line #</b>	<b>Description</b>
6	Unclassified Excavation
12	Borrow Excavation
295	Aggregate Base Course
or	
6	Unclassified Excavation
12	Borrow Excavation
299	Asphalt Concrete Base Course, Type B25.0C

**SPECIALTY ITEMS:**

(7-1-95)(Rev. 1-17-12)

108-6

SP1 G37

Items listed below will be the specialty items for this contract (see Article 108-6 of the 2012 *Standard Specifications*).

<b>Line #</b>	<b>Description</b>
105-114	Guardrail
115-117	Fencing
124-146, 179, 184	Signing
158-162, 168-170	Long-Life Pavement Markings
177-178	Permanent Pavement Markers
185-203	Utility Construction
204-238, 240	Erosion Control
239	Reforestation
241-294	Signals/ITS System
308-310, 312-314	Drilled Piers

**FUEL PRICE ADJUSTMENT:**

(11-15-05) (Rev. 2-18-14)

109-8

SP1 G43

Revise the 2012 *Standard Specifications* as follows:

**Page 1-83, Article 109-8, Fuel Price Adjustments**, add the following:

The base index price for DIESEL #2 FUEL is \$ **1.6761** per gallon. Where any of the following are included as pay items in the contract, they will be eligible for fuel price adjustment.

The pay items and the fuel factor used in calculating adjustments to be made will be as follows:

<b>Description</b>	<b>Units</b>	<b>Fuel Usage Factor Diesel</b>
Unclassified Excavation	Gal/CY	0.29

Borrow Excavation	Gal/CY	0.29
Class IV Subgrade Stabilization	Gal/Ton	0.55
Aggregate Base Course	Gal/Ton	0.55
Sub-Ballast	Gal/Ton	0.55
Asphalt Concrete Base Course, Type ____	Gal/Ton	2.90
Asphalt Concrete Intermediate Course, Type ____	Gal/Ton	2.90
Asphalt Concrete Surface Course, Type ____	Gal/Ton	2.90
Open-Graded Asphalt Friction Course	Gal/Ton	2.90
Permeable Asphalt Drainage Course, Type ____	Gal/Ton	2.90
Sand Asphalt Surface Course, Type ____	Gal/Ton	2.90
Aggregate for Cement Treated Base Course	Gal/Ton	0.55
Portland Cement for Cement Treated Base Course	Gal/Ton	0.55
__ " Portland Cement Concrete Pavement	Gal/SY	0.245
Concrete Shoulders Adjacent to __ " Pavement	Gal/SY	0.245

**PAYOUT SCHEDULE:**

(1-19-10) (Rev. 1-17-12)

108

SP1 G57

Submit an Anticipated Monthly Payout Schedule prior to beginning construction. The Anticipated Monthly Payout Schedule will be used by the Department to monitor funding levels for this project. Include a monthly percentage breakdown (in terms of the total contract amount) of the work anticipated to be completed. The schedule should begin with the date the Contractor plans to begin construction and end with the anticipated completion date. Submit updates of the Anticipated Monthly Payout Schedule on March 15, June 15, September 15, and December 15 of each calendar year until project acceptance. Submit the original Anticipated Monthly Payout Schedule and all subsequent updates to the Resident Engineer with a copy to the State Construction Engineer at 1 South Wilmington Street, 1543 Mail Service Center, Raleigh, NC 27699-1543.

**SCHEDULE OF ESTIMATED COMPLETION PROGRESS:**

(7-15-08) (Rev. 5-16-17)

108-2

SP1 G58

The Contractor's attention is directed to the Standard Special Provision entitled *Availability of Funds Termination of Contracts* included elsewhere in this proposal. The Department of Transportation's schedule of estimated completion progress for this project as required by that Standard Special Provision is as follows:

	<b><u>Fiscal Year</u></b>	<b><u>Progress (% of Dollar Value)</u></b>
2018	(7/01/17 - 6/30/18)	<b>25%</b> of Total Amount Bid
2019	(7/01/18 - 6/30/19)	<b>34%</b> of Total Amount Bid
2020	(7/01/19 - 6/30/20)	<b>26%</b> of Total Amount Bid
2021	(7/01/20 - 6/30/21)	<b>15%</b> of Total Amount Bid

The Contractor shall also furnish his own progress schedule in accordance with Article 108-2 of the *2012 Standard Specifications*. Any acceleration of the progress as shown by the Contractor's progress schedule over the progress as shown above shall be subject to the approval of the Engineer.

**DISADVANTAGED BUSINESS ENTERPRISE:**

(10-16-07)(Rev. 1-17-17)

102-15(J)

SP1 G61

**Description**

The purpose of this Special Provision is to carry out the U.S. Department of Transportation's policy of ensuring nondiscrimination in the award and administration of contracts financed in whole or in part with Federal funds. This provision is guided by 49 CFR Part 26.

**Definitions**

*Additional DBE Subcontractors* - Any DBE submitted at the time of bid that will not be used to meet the DBE goal. No submittal of a Letter of Intent is required.

*Committed DBE Subcontractor* - Any DBE submitted at the time of bid that is being used to meet the DBE goal by submission of a Letter of Intent. Or any DBE used as a replacement for a previously committed DBE firm.

*Contract Goal Requirement* - The approved DBE participation at time of award, but not greater than the advertised contract goal.

*DBE Goal* - A portion of the total contract, expressed as a percentage, that is to be performed by committed DBE subcontractor(s).

*Disadvantaged Business Enterprise (DBE)* - A firm certified as a Disadvantaged Business Enterprise through the North Carolina Unified Certification Program.

*Goal Confirmation Letter* - Written documentation from the Department to the bidder confirming the Contractor's approved, committed DBE participation along with a listing of the committed DBE firms.

*Manufacturer* - A firm that operates or maintains a factory or establishment that produces on the premises, the materials or supplies obtained by the Contractor.

*Regular Dealer* - A firm that owns, operates, or maintains a store, warehouse, or other establishment in which the materials or supplies required for the performance of the contract are bought, kept in stock, and regularly sold to the public in the usual course of business. A regular dealer engages in, as its principal business and in its own name, the purchase and sale or lease of the products in question. A regular dealer in such bulk items as steel, cement, gravel, stone, and petroleum products need not keep such products in stock, if it owns and operates distribution equipment for the products. Brokers and packagers are not regarded as manufacturers or regular dealers within the meaning of this section.

*North Carolina Unified Certification Program (NCUCP)* - A program that provides comprehensive services and information to applicants for DBE certification, such that an applicant is required to apply only once for a DBE certification that will be honored by all recipients of USDOT funds in the state and not limited to the Department of Transportation only. The Certification Program is in accordance with 49 CFR Part 26.



*United States Department of Transportation (USDOT)* - Federal agency responsible for issuing regulations (49 CFR Part 26) and official guidance for the DBE program.

### **Forms and Websites Referenced in this Provision**

*DBE Payment Tracking System* - On-line system in which the Contractor enters the payments made to DBE subcontractors who have performed work on the project.  
<https://apps.dot.state.nc.us/Vendor/PaymentTracking/>

*DBE-IS Subcontractor Payment Information* - Form for reporting the payments made to all DBE firms working on the project. This form is for paper bid projects only.  
<https://connect.ncdot.gov/business/Turnpike/Documents/Form%20DBE-IS%20Subcontractor%20Payment%20Information.pdf>

*RF-1 DBE Replacement Request Form* - Form for replacing a committed DBE.  
<http://connect.ncdot.gov/projects/construction/Construction%20Forms/DBE%20MBE%20WBE%20Replacement%20Request%20Form.pdf>

*SAF Subcontract Approval Form* - Form required for approval to sublet the contract.  
<http://connect.ncdot.gov/projects/construction/Construction%20Forms/Subcontract%20Approval%20Form%20Rev.%202012.zip>

*JC-1 Joint Check Notification Form* - Form and procedures for joint check notification. The form acts as a written joint check agreement among the parties providing full and prompt disclosure of the expected use of joint checks.  
<http://connect.ncdot.gov/projects/construction/Construction%20Forms/Joint%20Check%20Notification%20Form.pdf>

*Letter of Intent* - Form signed by the Contractor and the DBE subcontractor, manufacturer or regular dealer that affirms that a portion of said contract is going to be performed by the signed DBE for the amount listed at the time of bid.  
<http://connect.ncdot.gov/letting/LetCentral/Letter%20of%20Intent%20to%20Perform%20as%20a%20Subcontractor.pdf>

*Listing of DBE Subcontractors Form* - Form for entering DBE subcontractors on a project that will meet this DBE goal. This form is for paper bids only.  
[http://connect.ncdot.gov/municipalities/Bid%20Proposals%20for%20LGA%20Content/08%20DBE%20Subcontractors%20\(Federal\).docx](http://connect.ncdot.gov/municipalities/Bid%20Proposals%20for%20LGA%20Content/08%20DBE%20Subcontractors%20(Federal).docx)

*Subcontractor Quote Comparison Sheet* - Spreadsheet for showing all subcontractor quotes in the work areas where DBEs quoted on the project. This sheet is submitted with good faith effort packages.  
<http://connect.ncdot.gov/business/SmallBusiness/Documents/DBE%20Subcontractor%20Quote%20Comparison%20Example.xls>

**DBE Goal**

The following DBE goal for participation by Disadvantaged Business Enterprises is established for this contract:

Disadvantaged Business Enterprises **12.0%**

- (A) *If the DBE goal is more than zero*, the Contractor shall exercise all necessary and reasonable steps to ensure that DBEs participate in at least the percent of the contract as set forth above as the DBE goal.
- (B) *If the DBE goal is zero*, the Contractor shall make an effort to recruit and use DBEs during the performance of the contract. Any DBE participation obtained shall be reported to the Department.

**Directory of Transportation Firms (Directory)**

Real-time information is available about firms doing business with the Department and firms that are certified through NCUCP in the Directory of Transportation Firms. Only firms identified in the Directory as DBE certified shall be used to meet the DBE goal. The Directory can be found at the following link. [https:// www.ebs.nc.gov/VendorDirectory/default.html](https://www.ebs.nc.gov/VendorDirectory/default.html)

The listing of an individual firm in the directory shall not be construed as an endorsement of the firm's capability to perform certain work.

**Listing of DBE Subcontractors**

At the time of bid, bidders shall submit all DBE participation that they anticipate to use during the life of the contract. Only those identified to meet the DBE goal will be considered committed, even though the listing shall include both committed DBE subcontractors and additional DBE subcontractors. Additional DBE subcontractor participation submitted at the time of bid will be used toward the Department's overall race-neutral goal. Only those firms with current DBE certification at the time of bid opening will be acceptable for listing in the bidder's submittal of DBE participation. The Contractor shall indicate the following required information:

- (A) Electronic Bids

Bidders shall submit a listing of DBE participation in the appropriate section of Expedite, the bidding software of Bid Express<sup>®</sup>.

- (1) Submit the names and addresses of DBE firms identified to participate in the contract. If the bidder uses the updated listing of DBE firms shown in Expedite, the bidder may use the dropdown menu to access the name and address of the DBE firm.

- (2) Submit the contract line numbers of work to be performed by each DBE firm. When no figures or firms are entered, the bidder will be considered to have no DBE participation.
- (3) The bidder shall be responsible for ensuring that the DBE is certified at the time of bid by checking the Directory of Transportation Firms. If the firm is not certified at the time of the bid-letting, that DBE's participation will not count towards achieving the DBE goal.

(B) Paper Bids

- (1) *If the DBE goal is more than zero,*
  - (a) Bidders, at the time the bid proposal is submitted, shall submit a listing of DBE participation, including the names and addresses on *Listing of DBE Subcontractors* contained elsewhere in the contract documents in order for the bid to be considered responsive. Bidders shall indicate the total dollar value of the DBE participation for the contract.
  - (b) If bidders have no DBE participation, they shall indicate this on the *Listing of DBE Subcontractors* by entering the word "None" or the number "0." This form shall be completed in its entirety. **Blank forms will not be deemed to represent zero participation.** Bids submitted that do not have DBE participation indicated on the appropriate form will not be read publicly during the opening of bids. The Department will not consider these bids for award and the proposal will be rejected.
  - (c) The bidder shall be responsible for ensuring that the DBE is certified at the time of bid by checking the Directory of Transportation Firms. If the firm is not certified at the time of the bid-letting, that DBE's participation will not count towards achieving the corresponding goal.
- (2) *If the DBE goal is zero,* entries on the *Listing of DBE Subcontractors* are not required for the zero goal, however any DBE participation that is achieved during the project shall be reported in accordance with requirements contained elsewhere in the special provision.

**DBE Prime Contractor**

When a certified DBE firm bids on a contract that contains a DBE goal, the DBE firm is responsible for meeting the goal or making good faith efforts to meet the goal, just like any other bidder. In most cases, a DBE bidder on a contract will meet the DBE goal by virtue of the work it performs on the contract with its own forces. However, all the work that is performed by the DBE bidder and any other DBE subcontractors will count toward the DBE goal. The DBE bidder shall list itself along with any DBE subcontractors, if any, in order to receive credit toward the DBE goal.

For example, if the DBE goal is 45% and the DBE bidder will only perform 40% of the contract work, the prime will list itself at 40%, and the additional 5% shall be obtained through additional DBE participation with DBE subcontractors or documented through a good faith effort.

DBE prime contractors shall also follow Sections A and B listed under *Listing of DBE Subcontractor* just as a non-DBE bidder would.

### **Written Documentation – Letter of Intent**

The bidder shall submit written documentation for each DBE that will be used to meet the DBE goal of the contract, indicating the bidder's commitment to use the DBE in the contract. This documentation shall be submitted on the Department's form titled *Letter of Intent*.

The documentation shall be received in the office of the State Contractor Utilization Engineer or at DBE@ncdot.gov no later than 10:00 a.m. of the sixth calendar day following opening of bids, unless the sixth day falls on an official state holiday. In that situation, it is due in the office of the State Contractor Utilization Engineer no later than 10:00 a.m. on the next official state business day.

If the bidder fails to submit the Letter of Intent from each committed DBE to be used toward the DBE goal, or if the form is incomplete (i.e. both signatures are not present), the DBE participation will not count toward meeting the DBE goal. If the lack of this participation drops the commitment below the DBE goal, the Contractor shall submit evidence of good faith efforts, completed in its entirety, to the State Contractor Utilization Engineer or DBE@ncdot.gov no later than 10:00 a.m. on the eighth calendar day following opening of bids, unless the eighth day falls on an official state holiday. In that situation, it is due in the office of the State Contractor Utilization Engineer no later than 10:00 a.m. on the next official state business day.

### **Submission of Good Faith Effort**

If the bidder fails to meet or exceed the DBE goal, the apparent lowest responsive bidder shall submit to the Department documentation of adequate good faith efforts made to reach the DBE goal.

A hard copy and an electronic copy of this information shall be received in the office of the State Contractor Utilization Engineer or at DBE@ncdot.gov no later than 10:00 a.m. on the sixth calendar day following opening of bids unless the sixth day falls on an official state holiday. In that situation, it is due in the office of the State Contractor Utilization Engineer no later than 10:00 a.m. on the next official state business day. If the contractor cannot send the information electronically, then one complete set and 9 copies of this information shall be received under the same time constraints above.

Note: Where the information submitted includes repetitious solicitation letters, it will be acceptable to submit a representative letter along with a distribution list of the firms that were solicited. Documentation of DBE quotations shall be a part of the good faith effort submittal. This documentation may include written subcontractor quotations, telephone log notations of verbal quotations, or other types of quotation documentation.

**Consideration of Good Faith Effort for Projects with DBE Goals More Than Zero**

Adequate good faith efforts mean that the bidder took all necessary and reasonable steps to achieve the goal which, by their scope, intensity, and appropriateness, could reasonably be expected to obtain sufficient DBE participation. Adequate good faith efforts also mean that the bidder actively and aggressively sought DBE participation. Mere *pro forma* efforts are not considered good faith efforts.

The Department will consider the quality, quantity, and intensity of the different kinds of efforts a bidder has made. Listed below are examples of the types of actions a bidder will take in making a good faith effort to meet the goal and are not intended to be exclusive or exhaustive, nor is it intended to be a mandatory checklist.

- (A) Soliciting through all reasonable and available means (e.g. attendance at pre-bid meetings, advertising, written notices, use of verifiable electronic means through the use of the NCDOT Directory of Transportation Firms) the interest of all certified DBEs who have the capability to perform the work of the contract. The bidder must solicit this interest within at least 10 days prior to bid opening to allow the DBEs to respond to the solicitation. Solicitation shall provide the opportunity to DBEs within the Division and surrounding Divisions where the project is located. The bidder must determine with certainty if the DBEs are interested by taking appropriate steps to follow up initial solicitations.
- (B) Selecting portions of the work to be performed by DBEs in order to increase the likelihood that the DBE goals will be achieved.
  - (1) Where appropriate, break out contract work items into economically feasible units to facilitate DBE participation, even when the prime contractor might otherwise prefer to perform these work items with its own forces.
  - (2) Negotiate with subcontractors to assume part of the responsibility to meet the contract DBE goal when the work to be sublet includes potential for DBE participation (2<sup>nd</sup> and 3<sup>rd</sup> tier subcontractors).
- (C) Providing interested DBEs with adequate information about the plans, specifications, and requirements of the contract in a timely manner to assist them in responding to a solicitation.
- (D)
  - (1) Negotiating in good faith with interested DBEs. It is the bidder's responsibility to make a portion of the work available to DBE subcontractors and suppliers and to select those portions of the work or material needs consistent with the available DBE subcontractors and suppliers, so as to facilitate DBE participation. Evidence of such negotiation includes the names, addresses, and telephone numbers of DBEs that were considered; a description of the information provided regarding the plans and specifications for the work selected for subcontracting; and evidence as to why additional agreements could not be reached for DBEs to perform the work.
  - (2) A bidder using good business judgment would consider a number of factors in negotiating with subcontractors, including DBE subcontractors, and would take

a firm's price and capabilities as well as contract goals into consideration. However, the fact that there may be some additional costs involved in finding and using DBEs is not in itself sufficient reason for a bidder's failure to meet the contract DBE goal, as long as such costs are reasonable. Also, the ability or desire of a prime contractor to perform the work of a contract with its own organization does not relieve the bidder of the responsibility to make good faith efforts. Bidding contractors are not, however, required to accept higher quotes from DBEs if the price difference is excessive or unreasonable.

- (E) Not rejecting DBEs as being unqualified without sound reasons based on a thorough investigation of their capabilities. The bidder's standing within its industry, membership in specific groups, organizations, or associates and political or social affiliations (for example, union vs. non-union employee status) are not legitimate causes for the rejection or non-solicitation of bids in the bidder's efforts to meet the project goal.
- (F) Making efforts to assist interested DBEs in obtaining bonding, lines of credit, or insurance as required by the recipient or bidder.
- (G) Making efforts to assist interested DBEs in obtaining necessary equipment, supplies, materials, or related assistance or services.
- (H) Effectively using the services of available minority/women community organizations; minority/women contractors' groups; Federal, State, and local minority/women business assistance offices; and other organizations as allowed on a case-by-case basis to provide assistance in the recruitment and placement of DBEs. Contact within 7 days from the bid opening the Business Opportunity and Work Force Development Unit at DBE@ncdot.gov to give notification of the bidder's inability to get DBE quotes.
- (I) Any other evidence that the bidder submits which shows that the bidder has made reasonable good faith efforts to meet the DBE goal.

In addition, the Department may take into account the following:

- (1) Whether the bidder's documentation reflects a clear and realistic plan for achieving the DBE goal.
- (2) The bidders' past performance in meeting the DBE goals.
- (3) The performance of other bidders in meeting the DBE goal. For example, when the apparent successful bidder fails to meet the DBE goal, but others meet it, you may reasonably raise the question of whether, with additional reasonable efforts the apparent successful bidder could have met the goal. If the apparent successful bidder fails to meet the DBE goal, but meets or exceeds the average DBE participation obtained by other bidders, the Department may view this, in conjunction with other factors, as evidence of the apparent successful bidder having made a good faith effort.

If the Department does not award the contract to the apparent lowest responsive bidder, the Department reserves the right to award the contract to the next lowest responsive bidder that can satisfy to the Department that the DBE goal can be met or that an adequate good faith effort has been made to meet the DBE goal.

### **Non-Good Faith Appeal**

The State Contractual Services Engineer will notify the contractor verbally and in writing of non-good faith. A contractor may appeal a determination of non-good faith made by the Goal Compliance Committee. If a contractor wishes to appeal the determination made by the Committee, they shall provide written notification to the State Contractual Services Engineer or at DBE@ncdot.gov. The appeal shall be made within 2 business days of notification of the determination of non-good faith.

### **Counting DBE Participation Toward Meeting DBE Goal**

#### (A) Participation

The total dollar value of the participation by a committed DBE will be counted toward the contract goal requirement. The total dollar value of participation by a committed DBE will be based upon the value of work actually performed by the DBE and the actual payments to DBE firms by the Contractor.

#### (B) Joint Checks

Prior notification of joint check use shall be required when counting DBE participation for services or purchases that involves the use of a joint check. Notification shall be through submission of Form JC-1 (*Joint Check Notification Form*) and the use of joint checks shall be in accordance with the Department's Joint Check Procedures.

#### (C) Subcontracts (Non-Trucking)

A DBE may enter into subcontracts. Work that a DBE subcontracts to another DBE firm may be counted toward the contract goal requirement. Work that a DBE subcontracts to a non-DBE firm does not count toward the contract goal requirement. If a DBE contractor or subcontractor subcontracts a significantly greater portion of the work of the contract than would be expected on the basis of standard industry practices, it shall be presumed that the DBE is not performing a commercially useful function. The DBE may present evidence to rebut this presumption to the Department. The Department's decision on the rebuttal of this presumption is subject to review by the Federal Highway Administration but is not administratively appealable to USDOT.

#### (D) Joint Venture

When a DBE performs as a participant in a joint venture, the Contractor may count toward its contract goal requirement a portion of the total value of participation with the DBE in the joint venture, that portion of the total dollar value being a distinct clearly defined portion of work that the DBE performs with its forces.

## (E) Suppliers

A contractor may count toward its DBE requirement 60 percent of its expenditures for materials and supplies required to complete the contract and obtained from a DBE regular dealer and 100 percent of such expenditures from a DBE manufacturer.

## (F) Manufacturers and Regular Dealers

A contractor may count toward its DBE requirement the following expenditures to DBE firms that are not manufacturers or regular dealers:

- (1) The fees or commissions charged by a DBE firm for providing a *bona fide* service, such as professional, technical, consultant, or managerial services, or for providing bonds or insurance specifically required for the performance of a DOT-assisted contract, provided the fees or commissions are determined to be reasonable and not excessive as compared with fees and commissions customarily allowed for similar services.
- (2) With respect to materials or supplies purchased from a DBE, which is neither a manufacturer nor a regular dealer, count the entire amount of fees or commissions charged for assistance in the procurement of the materials and supplies, or fees or transportation charges for the delivery of materials or supplies required on a job site (but not the cost of the materials and supplies themselves), provided the fees are determined to be reasonable and not excessive as compared with fees customarily allowed for similar services.

**Commercially Useful Function**

## (A) DBE Utilization

The Contractor may count toward its contract goal requirement only expenditures to DBEs that perform a commercially useful function in the work of a contract. A DBE performs a commercially useful function when it is responsible for execution of the work of the contract and is carrying out its responsibilities by actually performing, managing, and supervising the work involved. To perform a commercially useful function, the DBE shall also be responsible with respect to materials and supplies used on the contract, for negotiating price, determining quality and quantity, ordering the material and installing (where applicable) and paying for the material itself. To determine whether a DBE is performing a commercially useful function, the Department will evaluate the amount of work subcontracted, industry practices, whether the amount the firm is to be paid under the contract is commensurate with the work it is actually performing and the DBE credit claimed for its performance of the work, and any other relevant factors.



**(B) DBE Utilization in Trucking**

The following factors will be used to determine if a DBE trucking firm is performing a commercially useful function:

- (1) The DBE shall be responsible for the management and supervision of the entire trucking operation for which it is responsible on a particular contract, and there shall not be a contrived arrangement for the purpose of meeting DBE goals.
- (2) The DBE shall itself own and operate at least one fully licensed, insured, and operational truck used on the contract.
- (3) The DBE receives credit for the total value of the transportation services it provides on the contract using trucks it owns, insures, and operates using drivers it employs.
- (4) The DBE may subcontract the work to another DBE firm, including an owner-operator who is certified as a DBE. The DBE who subcontracts work to another DBE receives credit for the total value of the transportation services the subcontracted DBE provides on the contract.
- (5) The DBE may also subcontract the work to a non-DBE firm, including from an owner-operator. The DBE who subcontracts the work to a non-DBE is entitled to credit for the total value of transportation services provided by the non-DBE subcontractor not to exceed the value of transportation services provided by DBE-owned trucks on the contract. Additional participation by non-DBE subcontractors receives credit only for the fee or commission it receives as a result of the subcontract arrangement. The value of services performed under subcontract agreements between the DBE and the Contractor will not count towards the DBE contract requirement.
- (6) A DBE may lease truck(s) from an established equipment leasing business open to the general public. The lease must indicate that the DBE has exclusive use of and control over the truck. This requirement does not preclude the leased truck from working for others during the term of the lease with the consent of the DBE, so long as the lease gives the DBE absolute priority for use of the leased truck. This type of lease may count toward the DBE's credit as long as the driver is under the DBE's payroll.
- (7) Subcontracted/leased trucks shall display clearly on the dashboard the name of the DBE that they are subcontracted/leased to and their own company name if it is not identified on the truck itself. Magnetic door signs are not permitted.

**DBE Replacement**

When a Contractor has relied on a commitment to a DBE firm (or an approved substitute DBE firm) to meet all or part of a contract goal requirement, the contractor shall not terminate the DBE for convenience. This includes, but is not limited to, instances in which the Contractor seeks to perform the work of the terminated subcontractor with another DBE subcontractor, a non-DBE

subcontractor, or with the Contractor's own forces or those of an affiliate. A DBE may only be terminated after receiving the Engineer's written approval based upon a finding of good cause for the termination. The prime contractor must give the DBE firm five (5) calendar days to respond to the prime contractor's notice of termination and advise the prime contractor and the Department of the reasons, if any, why the firm objects to the proposed termination of its subcontract and why the Department should not approve the action.

All requests for replacement of a committed DBE firm shall be submitted to the Engineer for approval on Form RF-1 (*DBE Replacement Request*). If the Contractor fails to follow this procedure, the Contractor may be disqualified from further bidding for a period of up to 6 months.

The Contractor shall comply with the following for replacement of a committed DBE:

(A) Performance Related Replacement

When a committed DBE is terminated for good cause as stated above, an additional DBE that was submitted at the time of bid may be used to fulfill the DBE commitment. A good faith effort will only be required for removing a committed DBE if there were no additional DBEs submitted at the time of bid to cover the same amount of work as the DBE that was terminated.

If a replacement DBE is not found that can perform at least the same amount of work as the terminated DBE, the Contractor shall submit a good faith effort documenting the steps taken. Such documentation shall include, but not be limited to, the following:

- (1) Copies of written notification to DBEs that their interest is solicited in contracting the work defaulted by the previous DBE or in subcontracting other items of work in the contract.
- (2) Efforts to negotiate with DBEs for specific subbids including, at a minimum:
  - (a) The names, addresses, and telephone numbers of DBEs who were contacted.
  - (b) A description of the information provided to DBEs regarding the plans and specifications for portions of the work to be performed.
- (3) A list of reasons why DBE quotes were not accepted.
- (4) Efforts made to assist the DBEs contacted, if needed, in obtaining bonding or insurance required by the Contractor.

(B) Decertification Replacement

- (1) When a committed DBE is decertified by the Department after the SAF (*Subcontract Approval Form*) has been received by the Department, the Department will not require the Contractor to solicit replacement DBE participation equal to the remaining work to be performed by the decertified firm. The

participation equal to the remaining work performed by the decertified firm will count toward the contract goal requirement.

- (2) When a committed DBE is decertified prior to the Department receiving the SAF (*Subcontract Approval Form*) for the named DBE firm, the Contractor shall take all necessary and reasonable steps to replace the DBE subcontractor with another DBE subcontractor to perform at least the same amount of work to meet the DBE goal requirement. If a DBE firm is not found to do the same amount of work, a good faith effort must be submitted to NCDOT (see A herein for required documentation).

### **Changes in the Work**

When the Engineer makes changes that result in the reduction or elimination of work to be performed by a committed DBE, the Contractor will not be required to seek additional participation. When the Engineer makes changes that result in additional work to be performed by a DBE based upon the Contractor's commitment, the DBE shall participate in additional work to the same extent as the DBE participated in the original contract work.

When the Engineer makes changes that result in extra work, which has more than a minimal impact on the contract amount, the Contractor shall seek additional participation by DBEs unless otherwise approved by the Engineer.

When the Engineer makes changes that result in an alteration of plans or details of construction, and a portion or all of the work had been expected to be performed by a committed DBE, the Contractor shall seek participation by DBEs unless otherwise approved by the Engineer.

When the Contractor requests changes in the work that result in the reduction or elimination of work that the Contractor committed to be performed by a DBE, the Contractor shall seek additional participation by DBEs equal to the reduced DBE participation caused by the changes.

### **Reports and Documentation**

A SAF (*Subcontract Approval Form*) shall be submitted for all work which is to be performed by a DBE subcontractor. The Department reserves the right to require copies of actual subcontract agreements involving DBE subcontractors.

When using transportation services to meet the contract commitment, the Contractor shall submit a proposed trucking plan in addition to the SAF. The plan shall be submitted prior to beginning construction on the project. The plan shall include the names of all trucking firms proposed for use, their certification type(s), the number of trucks owned by the firm, as well as the individual truck identification numbers, and the line item(s) being performed.

Within 30 calendar days of entering into an agreement with a DBE for materials, supplies or services, not otherwise documented by the SAF as specified above, the Contractor shall furnish the Engineer a copy of the agreement. The documentation shall also indicate the percentage (60% or 100%) of expenditures claimed for DBE credit.

**Reporting Disadvantaged Business Enterprise Participation**

The Contractor shall provide the Engineer with an accounting of payments made to all DBE firms, including material suppliers and contractors at all levels (prime, subcontractor, or second tier subcontractor). This accounting shall be furnished to the Engineer for any given month by the end of the following month. Failure to submit this information accordingly may result in the following action:

- (A) Withholding of money due in the next partial pay estimate; or
- (B) Removal of an approved contractor from the prequalified bidders' list or the removal of other entities from the approved subcontractors list.

While each contractor (prime, subcontractor, 2nd tier subcontractor) is responsible for accurate accounting of payments to DBEs, it shall be the prime contractor's responsibility to report all monthly and final payment information in the correct reporting manner.

Failure on the part of the Contractor to submit the required information in the time frame specified may result in the disqualification of that contractor and any affiliate companies from further bidding until the required information is submitted.

Failure on the part of any subcontractor to submit the required information in the time frame specified may result in the disqualification of that contractor and any affiliate companies from being approved for work on future DOT projects until the required information is submitted.

Contractors reporting transportation services provided by non-DBE lessees shall evaluate the value of services provided during the month of the reporting period only.

At any time, the Engineer can request written verification of subcontractor payments.

The Contractor shall report the accounting of payments through the Department's DBE Payment Tracking System.

**Failure to Meet Contract Requirements**

Failure to meet contract requirements in accordance with Subarticle 102-15(J) of the *2012 Standard Specifications* may be cause to disqualify the Contractor.

**CERTIFICATION FOR FEDERAL-AID CONTRACTS:**

(3-21-90)

SP1 G85

The prospective participant certifies, by signing and submitting this bid or proposal, to the best of his or her knowledge and belief, that:

- (A) No Federal appropriated funds have been paid or will be paid, by or on behalf of the undersigned, to any person for influencing or attempting to influence an officer or employee of any Federal agency, a Member of Congress, an officer or employee of Congress, or an employee of a Member of Congress in connection with the awarding of any Federal contract, the making of any Federal grant, the making of any Federal loan, the

entering into of any cooperative agreement, and the extension, continuation, renewal, amendment, or modification of any Federal contract, grant, loan, or cooperative agreement.

- (B) If any funds other than Federal appropriated funds have been paid or will be paid to any person for influencing or attempting to influence an officer or employee of any Federal agency, a Member of Congress, an officer or employee of Congress, or an employee of a Member of Congress in connection with this Federal contract, grant, loan, or cooperative agreement, the undersigned shall complete and submit Standard Form-LLL, *Disclosure Form to Report Lobbying*, in accordance with its instructions.

This certification is a material representation of fact upon which reliance was placed when this transaction was made or entered into. Submission of this certification is a prerequisite for making or entering into this transaction imposed by *Section 1352, Title 31, U.S. Code*. Any person who fails to file the required certification shall be subject to a civil penalty of not less than \$10,000 and not more than \$100,000 for each such failure.

The prospective participant also agrees by submitting his or her bid or proposal that he or she shall require that the language of this certification be included in all lower tier subcontracts, which exceed \$100,000 and that all such subrecipients shall certify and disclose accordingly.

**CONTRACTOR'S LICENSE REQUIREMENTS:**

(7-1-95)

102-14

SP1 G88

If the successful bidder does not hold the proper license to perform any plumbing, heating, air conditioning, or electrical work in this contract, he will be required to sublet such work to a contractor properly licensed in accordance with *Article 2 of Chapter 87 of the General Statutes* (licensing of heating, plumbing, and air conditioning contractors) and *Article 4 of Chapter 87 of the General Statutes* (licensing of electrical contractors).

**U.S. DEPARTMENT OF TRANSPORTATION HOTLINE:**

(11-22-94)

108-5

SP1 G100

To report bid rigging activities call: **1-800-424-9071**

The U.S. Department of Transportation (DOT) operates the above toll-free hotline Monday through Friday, 8:00 a.m. to 5:00 p.m. eastern time. Anyone with knowledge of possible bid rigging, bidder collusion, or other fraudulent activities should use the hotline to report such activities.

The hotline is part of the DOT's continuing effort to identify and investigate highway construction contract fraud and abuse is operated under the direction of the DOT Inspector General. All information will be treated confidentially and caller anonymity will be respected.

**CARGO PREFERENCE ACT:**

(2-16-16)

Privately owned United States-flag commercial vessels transporting cargoes are subject to the Cargo Preference Act (CPA) of 1954 requirements and regulations found in 46 CFR 381.7. Contractors are directed to clause (b) of 46 CFR 381.7 as follows:

- (b) Contractor and Subcontractor Clauses. "Use of United States-flag vessels: The contractor agrees-
- “(1) To utilize privately owned United States-flag commercial vessels to ship at least 50 percent of the gross tonnage (computed separately for dry bulk carriers, dry cargo liners, and tankers) involved, whenever shipping any equipment, material, or commodities pursuant to this contract, to the extent such vessels are available at fair and reasonable rates for United States-flag commercial vessels.
- (2) To furnish within 20 days following the date of loading for shipments originating within the United States or within 30 working days following the date of loading for shipments originating outside the United States a legible copy of a rated, 'on-board' commercial ocean bill-of-lading in English for each shipment of cargo described in paragraph (b) (1) of this section to both the Contracting Officer (through the prime contractor in the case of subcontractor bills-of-lading) and to the Division of National Cargo, Office of Market Development, Maritime Administration, Washington, DC 20590.
- (3) To insert the substance of the provisions of this clause in all subcontracts issued pursuant to this contract."

**SUBSURFACE INFORMATION:**

(7-1-95)

450

SP1 G112 D

Subsurface information is available on the roadway and structure portions of this project.

**LOCATING EXISTING UNDERGROUND UTILITIES:**

(3-20-12)

105

SP1 G115

Revise the *2012 Standard Specifications* as follows:

**Page 1-43, Article 105-8, line 28, after the first sentence, add the following:**

Identify excavation locations by means of pre-marking with white paint, flags, or stakes or provide a specific written description of the location in the locate request.

**VALUE ENGINEERING PROPOSAL:**

(05-19-15)

104

SP01 G116

Revise the *2012 Standard Specifications* as follows:

**Page 1-36, Subarticle 104-12(B) Evaluation of Proposals, lines 42-44, replace the fourth sentence of the second paragraph with the following:**

Pending execution of a formal supplemental agreement implementing an approved VEP and transferal of final plans (hard copy and electronic) sealed by an engineer licensed in the State of North Carolina incorporating an approved VEP to the Resident Engineer and the State Value Management Engineer, the Contractor shall remain obligated to perform the work in accordance with the terms of the existing contract.

**Page 1-37, Subarticle 104-12(D) Preliminary Review, lines 9-12,** replace the first sentence of the first paragraph with the following:

Should the Contractor desire a preliminary review of a possible VEP, before expending considerable time and expense in full development, a copy of the Preliminary VEP shall be submitted to the Resident Engineer and the State Value Management Engineer at ValueManagementUnit@ncdot.gov.

**Page 1-37, Subarticle 104-12(E) Final Proposal, lines 22-23,** replace the first sentence of the first paragraph with the following:

A copy of the Final VEP shall be submitted by the Contractor to the Resident Engineer and the State Value Management Engineer at ValueManagementUnit@ncdot.gov.

**Page 1-38, Subarticle 104-12(F) Modifications, lines 2-8,** replace the first paragraph with the following:

To facilitate the preparation of revisions to contract drawings, the Contractor may purchase reproducible copies of drawings for his use through the Department's Value Management Unit. The preparation of new design drawings by or for the Contractor shall be coordinated with the appropriate Design Branch through the State Value Management Engineer. The Contractor shall provide, at no charge to the Department, one set of reproducible drawings of the approved design needed to implement the VEP. Drawings (hard copy and electronic) which are sealed by an engineer licensed in the State of North Carolina shall be submitted to the State Value Management Engineer no later than ten (10) business days after acceptance of a VEP unless otherwise permitted.

**Page 1-38, Subarticle 104-12(F) Modifications, line 17,** add the following at the end of the third paragraph:

Supplemental agreements executed for design-bid-build contracts shall reflect any realized savings in the corresponding line items. Supplemental agreements executed for design-build contracts shall add one line item deducting the full savings from the total contract price and one line item crediting the Contractor with 50% of the total VEP savings.

**Page 1-38, Subarticle 104-12(F) Modifications, lines 45-47,** replace the eighth paragraph with the following:

Unless and until a supplemental agreement is executed and issued by the Department and final plans (hard copy and electronic) sealed by an engineer licensed in the State of North Carolina incorporating an approved VEP have been provided to the Resident Engineer and the State Value Management Engineer, the Contractor shall remain obligated to perform the work in accordance with the terms of the existing contract.

**RESOURCE CONSERVATION AND ENV. SUSTAINABLE PRACTICES:**

(5-21-13) (Rev. 5-19-15)

104-13

SP1 G118

In accordance with North Carolina Executive Order 156, NCGS 130A-309.14(3), and NCGS 136-28.8, it is the objective of the Department to aid in the reduction of materials that become a part of

our solid waste stream, to divert materials from landfills, to find ways to recycle and reuse materials, to consider and minimize, where economically feasible, the environmental impacts associated with agency land use and acquisition, construction, maintenance and facility management for the benefit of the Citizens of North Carolina.

To achieve the mission of reducing environmental impacts across the state, the Department is committed to supporting the efforts to initiate, develop and use products and construction methods that incorporate the use of recycled, solid waste products and environmentally sustainable practices in accordance with Article 104-13 of the *Standard Specifications*.

Report the quantities of reused or recycled materials either incorporated in the project or diverted from landfills and any practice that minimizes the environmental impact on the project annually on the Project Construction Reuse and Recycling Reporting Form. The Project Construction Reuse and Recycling Reporting Form and a location tool for local recycling facilities are available at:

<http://connect.ncdot.gov/resources/Environmental/Pages/North-Carolina-Recycling-Locations.aspx>.

Submit the Project Construction Reuse and Recycling Reporting Form by August 1 annually to [valuemanagementunit@ncdot.gov](mailto:valuemanagementunit@ncdot.gov). For questions regarding the form or reporting, please contact the State Value Management Engineer at 919-707-4810.

#### **DOMESTIC STEEL:**

(4-16-13)

106

SP1 G120

Revise the *2012 Standard Specifications* as follows:

**Page 1-49, Subarticle 106-1(B) Domestic Steel, lines 2-7**, replace the first paragraph with the following:

All steel and iron products that are permanently incorporated into this project shall be produced in the United States except minimal amounts of foreign steel and iron products may be used provided the combined material cost of the items involved does not exceed 0.1% of the total amount bid for the entire project or \$2,500, whichever is greater. If invoices showing the cost of the material are not provided, the amount of the bid item involving the foreign material will be used for calculations. This minimal amount of foreign produced steel and iron products permitted for use is not applicable to high strength fasteners. Domestically produced high strength fasteners are required.

#### **MAINTENANCE OF THE PROJECT:**

(11-20-07) (Rev. 1-17-12)

104-10

SP1 G125

Revise the *2012 Standard Specifications* as follows:

**Page 1-35, Article 104-10 Maintenance of the Project, line 25**, add the following after the first sentence of the first paragraph:

All guardrail/guiderail within the project limits shall be included in this maintenance.



**Page 1-35, Article 104-10 Maintenance of the Project, line 30**, add the following as the last sentence of the first paragraph:

The Contractor shall perform weekly inspections of guardrail and guiderail and shall report damages to the Engineer on the same day of the weekly inspection. *Where damaged guardrail or guiderail is repaired or replaced as a result of maintaining the project in accordance with this article, such repair or replacement shall be performed within 7 consecutive calendar days of such inspection report.*

**Page 1-35, Article 104-10 Maintenance of the Project, lines 42-44**, replace the last sentence of the last paragraph with the following:

The Contractor will not be directly compensated for any maintenance operations necessary, except for maintenance of guardrail/guiderail, as this work will be considered incidental to the work covered by the various contract items. The provisions of Article 104-7, Extra Work, and Article 104-8, Compensation and Record Keeping will apply to authorized maintenance of guardrail/guiderail. Performance of weekly inspections of guardrail/guiderail, and the damage reports required as described above, will be considered to be an incidental part of the work being paid for by the various contract items.

**COOPERATION BETWEEN CONTRACTORS:**

(7-1-95)

105-7

SP1 G133

The Contractor's attention is directed to Article 105-7 of the *2012 Standard Specifications*.

R-2577A in Forsyth County, scheduled for the October 2021 Letting, is located adjacent to this project.

U-2579B (C203484) in Forsyth County is currently under construction and is located adjacent to this project; U-2579B will not be completed prior this project's letting.

U-2579D / U-2579E / U-2579F in Forsyth County, scheduled for the February 2018 Letting, is located adjacent to this project.

The Contractor on this project shall cooperate with the Contractor working within or adjacent to the limits of this project to the extent that the work can be carried out to the best advantage of all concerned.

**BID DOCUMENTATION:**

(1-1-02) (Rev.8-18-15)

103

SP1 G142

**General**

The successful Bidder (Contractor) shall submit the original, unaltered bid documentation or a certified copy of the original, unaltered bid documentation used to prepare the bid for this contract to the Department within 10 days after receipt of notice of award of contract. Such documentation shall be placed in escrow with a banking institution or other bonded document storage facility selected by the Department.

The Department will not execute the contract until the original, unaltered bid documentation or a certified copy of the original, unaltered bid documentation has been received by the Department.

### **Terms**

*Bid Documentation* - Bid Documentation shall mean all written information, working papers, computer printouts, electronic media, charts, and all other data compilations which contain or reflect information, data, and calculations used by the Bidder in the preparation of the bid. The term *bid documentation* includes, but is not limited to, contractor equipment rates, contractor overhead rates, labor rates, efficiency or productivity factors, arithmetical calculations, and quotations from subcontractors and material suppliers to the extent that such rates and quotations were used by the Bidder in formulating and determining the bid. The term *bid documentation* also includes any manuals, which are standard to the industry used by the Bidder in determining the bid. Such manuals may be included in the bid documentation by reference. Such reference shall include the name and date of the publication and the publisher. *Bid Documentation* does not include bid documents provided by the Department for use by the Bidder in bidding on this project. The Bid Documentation can be in the form of electronic submittal (i.e. thumb drive) or paper. If the Bidder elects to submit the Bid Documentation in electronic format, the Department requires a backup submittal (i.e. a second thumb drive) in case one is corrupted.

*Contractor's Representative* - Officer of the Contractor's company; if not an officer, the Contractor shall supply a letter signed and notarized by an officer of the Contractor's company, granting permission for the representative to sign the escrow agreement on behalf of the Contractor.

*Escrow Agent* - Officer of the select banking institution or other bonded document storage facility authorized to receive and release bid documentation.

### **Escrow Agreement Information**

A draft copy of the Escrow Agreement will be mailed to the Bidder after the notice of award for informational purposes. The Bidder and Department will sign the actual Escrow Agreement at the time the bid documentation is delivered to the Escrow Agent.

### **Failure to Provide Bid Documentation**

The Bidder's failure to provide the original, unaltered bid documentation or a certified copy of the original, unaltered bid documentation within 10 days after the notice of award is received may be just cause for rescinding the award of the contract and may result in the removal of the Bidder from the Department's list of qualified bidders for a period of up to 180 days. Award may then be made to the next lowest responsible bidder or the work may be readvertised and constructed under the contract or otherwise, as the Department may decide.

### **Submittal of Bid Documentation**

- (A) Appointment – Email [specs@ncdot.gov](mailto:specs@ncdot.gov) or call 919.707.6900 to schedule an appointment.
- (B) Delivery - A representative of the Bidder shall deliver the original, unaltered bid documentation or a certified copy of the original, unaltered bid documentation to the

Department, in a container suitable for sealing, within 10 days after the notice of award is received.

- (C) Packaging – The container shall be no larger than 15.5 inches in length by 12 inches wide by 11 inches high and shall be water resistant. The container shall be clearly marked on the face and the back of the container with the following information: Bid Documentation, Bidder's Name, Bidder's Address, Date of Escrow Submittal, Contract Number, TIP Number if applicable, and County.

### **Affidavit**

Bid documentation will be considered a certified copy if the Bidder includes an affidavit stating that the enclosed documentation is an EXACT copy of the original documentation used by the Bidder to determine the bid for this project. The affidavit shall also list each bid document with sufficient specificity so a comparison may be made between the list and the bid documentation to ensure that all of the bid documentation listed in the affidavit has been enclosed for escrow. The affidavit shall attest that the affiant has personally examined the bid documentation, that the affidavit lists all of the documents used by the Bidder to determine the bid for this project, and that all bid documentation has been included. The affidavit shall be signed by a chief officer of the company, have the person's name and title typed below the signature, and the signature shall be notarized at the bottom of the affidavit.

### **Verification**

Upon delivery of the bid documentation, the Department's Contract Officer and the Bidder's representative will verify the accuracy and completeness of the bid documentation compared to the affidavit. Should a discrepancy exist, the Bidder's representative shall immediately furnish the Department's Contract Officer with any other needed bid documentation. The Department's Contract Officer upon determining that the bid documentation is complete will, in the presence of the Bidder's representative, immediately place the complete bid documentation and affidavit in the container and seal it. Both parties will deliver the sealed container to the Escrow Agent for placement in a safety deposit box, vault, or other secure accommodation.

### **Confidentiality of Bid Documentation**

The bid documentation and affidavit in escrow are, and will remain, the property of the Bidder. The Department has no interest in, or right to, the bid documentation and affidavit other than to verify the contents and legibility of the bid documentation unless the Contractor gives written notice of intent to file a claim, files a written claim, files a written and verified claim, or initiates litigation against the Department. In the event of such written notice of intent to file a claim, filing of a written claim, filing a written and verified claim, or initiation of litigation against the Department, or receipt of a letter from the Contractor authorizing release, the bid documentation and affidavit may become the property of the Department for use in considering any claim or in litigation as the Department may deem appropriate.

Any portion or portions of the bid documentation designated by the Bidder as a *trade secret* at the time the bid documentation is delivered to the Department's Contract Officer shall be protected from disclosure as provided by *G.S. 132-1.2*.

**Duration and Use**

The bid documentation and affidavit shall remain in escrow until 60 calendar days from the time the Contractor receives the final estimate; or until such time as the Contractor:

- (A) Gives written notice of intent to file a claim,
- (B) Files a written claim,
- (C) Files a written and verified claim,
- (D) Initiates litigation against the Department related to the contract; or
- (E) Authorizes in writing its release.

Upon the giving of written notice of intent to file a claim, filing a written claim, filing a written and verified claim, or the initiation of litigation by the Contractor against the Department, or receipt of a letter from the Contractor authorizing release, the Department may obtain the release and custody of the bid documentation.

The Bidder certifies and agrees that the sealed container placed in escrow contains all of the bid documentation used to determine the bid and that no other bid documentation shall be relevant or material in litigation over claims brought by the Contractor arising out of this contract.

**Release of Bid Documentation to the Contractor**

If the bid documentation remains in escrow 60 calendar days after the time the Contractor receives the final estimate and the Contractor has not filed a written claim, filed a written and verified claim, or has not initiated litigation against the Department related to the contract, the Department will instruct the Escrow Agent to release the sealed container to the Contractor.

The Contractor will be notified by certified letter from the Escrow Agent that the bid documentation will be released to the Contractor. The Contractor or his representative shall retrieve the bid documentation from the Escrow Agent within 30 days of the receipt of the certified letter. If the Contractor does not receive the documents within 30 days of the receipt of the certified letter, the Department will contact the Contractor to determine final dispersion of the bid documentation.

**Payment**

The cost of the escrow will be borne by the Department. There will be no separate payment for all costs of compilation of the data, container, or verification of the bid documentation. Payment at the various contract unit or lump sum prices in the contract will be full compensation for all such costs.

**TWELVE MONTH GUARANTEE:**

(7-15-03)

108

SP1 G145

- (A) The Contractor shall guarantee materials and workmanship against latent and patent defects arising from faulty materials, faulty workmanship or negligence for a period of twelve months following the date of final acceptance of the work for maintenance and shall replace such defective materials and workmanship without cost to the Department. The Contractor will not be responsible for damage due to faulty design, normal wear and tear, for negligence on the part of the Department, and/or for use in excess of the design.
- (B) Where items of equipment or material carry a manufacturer's guarantee for any period in excess of twelve months, then the manufacturer's guarantee shall apply for that particular piece of equipment or material. The Department's first remedy shall be through the manufacturer although the Contractor is responsible for invoking the warranted repair work with the manufacturer. The Contractor's responsibility shall be limited to the term of the manufacturer's guarantee. NCDOT would be afforded the same warranty as provided by the Manufacturer.

This guarantee provision shall be invoked only for major components of work in which the Contractor would be wholly responsible for under the terms of the contract. Examples would include pavement structures, bridge components, and sign structures. This provision will not be used as a mechanism to force the Contractor to return to the project to make repairs or perform additional work that the Department would normally compensate the Contractor for. In addition, routine maintenance activities (i.e. mowing grass, debris removal, ruts in earth shoulders,) are not parts of this guarantee.

Appropriate provisions of the payment and/or performance bonds shall cover this guarantee for the project.

To ensure uniform application statewide the Division Engineer will forward details regarding the circumstances surrounding any proposed guarantee repairs to the Chief Engineer for review and approval prior to the work being performed.

**IRAN DIVESTMENT ACT:**

(5-17-16)

SP01 G151

As a result of the Iran Divestment Act of 2015 (Act), Article 6E, N.C. General Statute § 147-86.55, the State Treasurer published the Final Divestment List (List) which includes the Final Divestment List-Iran, and the Parent and Subsidiary Guidance-Iran. These lists identify companies and persons engaged in investment activities in Iran and will be updated every 180 days. The List can be found at <https://www.nctreasurer.com/inside-the-department/OpenGovernment/Pages/Iran-Divestment-Act-Resources.aspx>

By submitting the Offer, the Contractor certifies that, as of the date of this bid, it is not on the then-current List created by the State Treasurer. The Contractor must notify the Department immediately if, at any time before the award of the contract, it is added to the List.

As an ongoing obligation, the Contractor must notify the Department immediately if, at any time during the contract term, it is added to the List. Consistent with § 147-86.59, the Contractor shall

not contract with any person to perform a part of the work if, at the time the subcontract is signed, that person is on the then-current List.

During the term of the Contract, should the Department receive information that a person is in violation of the Act as stated above, the Department will offer the person an opportunity to respond and the Department will take action as appropriate and provided for by law, rule, or contract.

**GIFTS FROM VENDORS AND CONTRACTORS:**

(12-15-09)

107-1

SP1 G152

By Executive Order 24, issued by Governor Perdue, and *N.C.G.S. § 133-32*, it is unlawful for any vendor or contractor (i.e. architect, bidder, contractor, construction manager, design professional, engineer, landlord, offeror, seller, subcontractor, supplier, or vendor), to make gifts or to give favors to any State employee of the Governor's Cabinet Agencies (i.e. Administration, Commerce, Correction, Crime Control and Public Safety, Cultural Resources, Environment and Natural Resources, Health and Human Services, Juvenile Justice and Delinquency Prevention, Revenue, Transportation, and the Office of the Governor). This prohibition covers those vendors and contractors who:

- (A) Have a contract with a governmental agency; or
- (B) Have performed under such a contract within the past year; or
- (C) Anticipate bidding on such a contract in the future.

For additional information regarding the specific requirements and exemptions, vendors and contractors are encouraged to review Executive Order 24 and *N.C.G.S. § 133-32*.

Executive Order 24 also encouraged and invited other State Agencies to implement the requirements and prohibitions of the Executive Order to their agencies. Vendors and contractors should contact other State Agencies to determine if those agencies have adopted Executive Order 24.

**LIABILITY INSURANCE:**

(5-20-14)

SP1 G160

Revise the *2012 Standard Specifications* as follows:

**Page 1-60, Article 107-15 LIABILITY INSURANCE, line 16**, add the following as the second sentence of the third paragraph:

Prior to beginning services, all contractors shall provide proof of coverage issued by a workers' compensation insurance carrier, or a certificate of compliance issued by the Department of Insurance for self-insured subcontractors, irrespective of whether having regularly in service fewer than three employees.

**EROSION AND SEDIMENT CONTROL/STORMWATER CERTIFICATION:**

(1-16-07) (Rev 11-22-16)

105-16, 225-2, 16

SP1 G180

**General**

Schedule and conduct construction activities in a manner that will minimize soil erosion and the resulting sedimentation and turbidity of surface waters. Comply with the requirements herein regardless of whether or not a National Pollution discharge Elimination System (NPDES) permit for the work is required.

Establish a chain of responsibility for operations and subcontractors' operations to ensure that the *Erosion and Sediment Control/Stormwater Pollution Prevention Plan* is implemented and maintained over the life of the contract.

- (A) *Certified Supervisor* - Provide a certified Erosion and Sediment Control/Stormwater Supervisor to manage the Contractor and subcontractor operations, insure compliance with Federal, State and Local ordinances and regulations, and manage the Quality Control Program.
- (B) *Certified Foreman* - Provide a certified, trained foreman for each construction operation that increases the potential for soil erosion or the possible sedimentation and turbidity of surface waters.
- (C) *Certified Installer* - Provide a certified installer to install or direct the installation for erosion or sediment/stormwater control practices.
- (D) *Certified Designer* - Provide a certified designer for the design of the erosion and sediment control/stormwater component of reclamation plans and, if applicable, for the design of the project erosion and sediment control/stormwater plan.

**Roles and Responsibilities**

- (A) *Certified Erosion and Sediment Control/Stormwater Supervisor* - The Certified Supervisor shall be Level II and responsible for ensuring the erosion and sediment control/stormwater plan is adequately implemented and maintained on the project and for conducting the quality control program. The Certified Supervisor shall be on the project within 24 hours notice from initial exposure of an erodible surface to the project's final acceptance. Perform the following duties:
  - (1) *Manage Operations* - Coordinate and schedule the work of subcontractors so that erosion and sediment control/stormwater measures are fully executed for each operation and in a timely manner over the duration of the contract.
    - (a) Oversee the work of subcontractors so that appropriate erosion and sediment control/stormwater preventive measures are conformed to at each stage of the work.
    - (b) Prepare the required National Pollutant Discharge Elimination System (NPDES) Inspection Record and submit to the Engineer.

- (c) Attend all weekly or monthly construction meetings to discuss the findings of the NPDES inspection and other related issues.
  - (d) Implement the erosion and sediment control/stormwater site plans requested.
  - (e) Provide any needed erosion and sediment control/stormwater practices for the Contractor's temporary work not shown on the plans, such as, but not limited to work platforms, temporary construction, pumping operations, plant and storage yards, and cofferdams.
  - (f) Acquire applicable permits and comply with requirements for borrow pits, dewatering, and any temporary work conducted by the Contractor in jurisdictional areas.
  - (g) Conduct all erosion and sediment control/stormwater work in a timely and workmanlike manner.
  - (h) Fully perform and install erosion and sediment control/stormwater work prior to any suspension of the work.
  - (i) Coordinate with Department, Federal, State and Local Regulatory agencies on resolution of erosion and sediment control/stormwater issues due to the Contractor's operations.
  - (j) Ensure that proper cleanup occurs from vehicle tracking on paved surfaces or any location where sediment leaves the Right-of-Way.
  - (k) Have available a set of erosion and sediment control/stormwater plans that are initialed and include the installation date of Best Management Practices. These practices shall include temporary and permanent groundcover and be properly updated to reflect necessary plan and field changes for use and review by Department personnel as well as regulatory agencies.
- (2) Requirements set forth under the NPDES Permit - The Department's NPDES Stormwater permit (NCS000250) outlines certain objectives and management measures pertaining to construction activities. The permit references *NCG010000, General Permit to Discharge Stormwater* under the NPDES, and states that the Department shall incorporate the applicable requirements into its delegated Erosion and Sediment Control Program for construction activities disturbing one or more acres of land. The Department further incorporates these requirements on all contracted bridge and culvert work at jurisdictional waters, regardless of size. Some of the requirements are, but are not limited to:
- (a) Control project site waste to prevent contamination of surface or ground waters of the state, i.e. from equipment operation/maintenance, construction materials, concrete washout, chemicals, litter, fuels, lubricants, coolants, hydraulic fluids, any other petroleum products, and sanitary waste.
  - (b) Inspect erosion and sediment control/stormwater devices and stormwater discharge outfalls at least once every 7 calendar days and within 24 hours after a rainfall event of 0.5 inch that occurs within a 24 hour period. Additional monitoring may be required at the discretion of Division of Water Resources personnel if the receiving stream is 303(d) listed for turbidity and the project has had documented problems managing turbidity.



- (c) Maintain an onsite rain gauge or use the Department's Multi-Sensor Precipitation Estimate website to maintain a daily record of rainfall amounts and dates.
  - (d) Maintain erosion and sediment control/stormwater inspection records for review by Department and Regulatory personnel upon request.
  - (e) Implement approved reclamation plans on all borrow pits, waste sites and staging areas.
  - (f) Maintain a log of turbidity test results as outlined in the Department's Procedure for Monitoring Borrow Pit Discharge.
  - (g) Provide secondary containment for bulk storage of liquid materials.
  - (h) Provide training for employees concerning general erosion and sediment control/stormwater awareness, the Department's NPDES Stormwater Permit NCS000250 requirements, and the applicable requirements of the *General Permit, NCG010000*.
  - (i) Report violations of the NPDES permit to the Engineer immediately who will notify the Division of Water Quality Regional Office within 24 hours of becoming aware of the violation.
- (3) Quality Control Program - Maintain a quality control program to control erosion, prevent sedimentation and follow provisions/conditions of permits. The quality control program shall:
- (a) Follow permit requirements related to the Contractor and subcontractors' construction activities.
  - (b) Ensure that all operators and subcontractors on site have the proper erosion and sediment control/stormwater certification.
  - (c) Notify the Engineer when the required certified erosion and sediment control/stormwater personnel are not available on the job site when needed.
  - (d) Conduct the inspections required by the NPDES permit.
  - (e) Take corrective actions in the proper timeframe as required by the NPDES permit for problem areas identified during the NPDES inspections.
  - (f) Incorporate erosion control into the work in a timely manner and stabilize disturbed areas with mulch/seed or vegetative cover on a section-by-section basis.
  - (g) Use flocculants approved by state regulatory authorities where appropriate and where required for turbidity and sedimentation reduction.
  - (h) Ensure proper installation and maintenance of temporary erosion and sediment control devices.
  - (i) Remove temporary erosion or sediment control devices when they are no longer necessary as agreed upon by the Engineer.
  - (j) The Contractor's quality control and inspection procedures shall be subject to review by the Engineer. Maintain NPDES inspection records and make records available at all times for verification by the Engineer.
- (B) *Certified Foreman* - At least one Certified Foreman shall be onsite for each type of work listed herein during the respective construction activities to control erosion, prevent sedimentation and follow permit provisions:

- (1) Foreman in charge of grading activities
- (2) Foreman in charge of bridge or culvert construction over jurisdictional areas
- (3) Foreman in charge of utility activities

The Contractor may request to use the same person as the Level II Supervisor and Level II Foreman. This person shall be onsite whenever construction activities as described above are taking place. This request shall be approved by the Engineer prior to work beginning.

The Contractor may request to name a single Level II Foreman to oversee multiple construction activities on small bridge or culvert replacement projects. This request shall be approved by the Engineer prior to work beginning.

- (C) *Certified Installers* - Provide at least one onsite, Level I Certified Installer for each of the following erosion and sediment control/stormwater crew:

- (1) Seeding and Mulching
- (2) Temporary Seeding
- (3) Temporary Mulching
- (4) Sodding
- (5) Silt fence or other perimeter erosion/sediment control device installations
- (6) Erosion control blanket installation
- (7) Hydraulic tackifier installation
- (8) Turbidity curtain installation
- (9) Rock ditch check/sediment dam installation
- (10) Ditch liner/matting installation
- (11) Inlet protection
- (12) Riprap placement
- (13) Stormwater BMP installations (such as but not limited to level spreaders, retention/detention devices)
- (14) Pipe installations within jurisdictional areas

If a Level I *Certified Installer* is not onsite, the Contractor may substitute a Level II Foreman for a Level I Installer, provided the Level II Foreman is not tasked to another crew requiring Level II Foreman oversight.

- (D) *Certified Designer* - Include the certification number of the Level III-B Certified Designer on the erosion and sediment control/stormwater component of all reclamation plans and if applicable, the certification number of the Level III-A Certified Designer on the design of the project erosion and sediment control/stormwater plan.

### **Preconstruction Meeting**

Furnish the names of the *Certified Erosion and Sediment Control/Stormwater Supervisor*, *Certified Foremen*, *Certified Installers* and *Certified Designer* and notify the Engineer of changes in certified personnel over the life of the contract within 2 days of change.

**Ethical Responsibility**

Any company performing work for the North Carolina Department of Transportation has the ethical responsibility to fully disclose any reprimand or dismissal of an employee resulting from improper testing or falsification of records.

**Revocation or Suspension of Certification**

Upon recommendation of the Chief Engineer to the certification entity, certification for *Supervisor, Certified Foremen, Certified Installers* and *Certified Designer* may be revoked or suspended with the issuance of an *Immediate Corrective Action (ICA), Notice of Violation (NOV)*, or *Cease and Desist Order* for erosion and sediment control/stormwater related issues.

The Chief Engineer may recommend suspension or permanent revocation of certification due to the following:

- (A) Failure to adequately perform the duties as defined within this certification provision.
- (B) Issuance of an ICA, NOV, or Cease and Desist Order.
- (C) Failure to fully perform environmental commitments as detailed within the permit conditions and specifications.
- (D) Demonstration of erroneous documentation or reporting techniques.
- (E) Cheating or copying another candidate's work on an examination.
- (F) Intentional falsification of records.
- (G) Directing a subordinate under direct or indirect supervision to perform any of the above actions.
- (H) Dismissal from a company for any of the above reasons.
- (I) Suspension or revocation of one's certification by another entity.

Suspension or revocation of a certification will be sent by certified mail to the certificant and the Corporate Head of the company that employs the certificant.

A certificant has the right to appeal any adverse action which results in suspension or permanent revocation of certification by responding, in writing, to the Chief Engineer within 10 calendar days after receiving notice of the proposed adverse action.

Chief Engineer  
1536 Mail Service Center  
Raleigh, NC 27699-1536

Failure to appeal within 10 calendar days will result in the proposed adverse action becoming effective on the date specified on the certified notice. Failure to appeal within the time specified will result in a waiver of all future appeal rights regarding the adverse action taken. The certificant will not be allowed to perform duties associated with the certification during the appeal process.

The Chief Engineer will hear the appeal and make a decision within 7 days of hearing the appeal. Decision of the Chief Engineer will be final and will be made in writing to the certificant.

If a certification is temporarily suspended, the certificant shall pass any applicable written examination and any proficiency examination, at the conclusion of the specified suspension period, prior to having the certification reinstated.

### **Measurement and Payment**

*Certified Erosion and Sediment Control/Stormwater Supervisor, Certified Foremen, Certified Installers and Certified Designer* will be incidental to the project for which no direct compensation will be made.

### **PROCEDURE FOR MONITORING BORROW PIT DISCHARGE:**

(2-20-07) (Rev. 3-19-13)

105-16, 230, 801

SP1 G181

Water discharge from borrow pit sites shall not cause surface waters to exceed 50 NTUs (nephelometric turbidity unit) in streams not designated as trout waters and 10 NTUs in streams, lakes or reservoirs designated as trout waters. For lakes and reservoirs not designated as trout waters, the turbidity shall not exceed 25 NTUs. If the turbidity exceeds these levels due to natural background conditions, the existing turbidity level shall not be increased.

If during any operating day, the downstream water quality exceeds the standard, the Contractor shall do all of the following:

- (A) Either cease discharge or modify the discharge volume or turbidity levels to bring the downstream turbidity levels into compliance, or
- (B) Evaluate the upstream conditions to determine if the exceedance of the standard is due to natural background conditions. If the background turbidity measurements exceed the standard, operation of the pit and discharge can continue as long as the stream turbidity levels are not increased due to the discharge.
- (C) Measure and record the turbidity test results (time, date and sampler) at all defined sampling locations 30 minutes after startup and at a minimum, one additional sampling of all sampling locations during that 24-hour period in which the borrow pit is discharging.
- (D) Notify DWQ within 24 hours of any stream turbidity standard exceedances that are not brought into compliance.

During the Environmental Assessment required by Article 230-4 of the *2012 Standard Specifications*, the Contractor shall define the point at which the discharge enters into the State's surface waters and the appropriate sampling locations. Sampling locations shall include points upstream and downstream from the point at which the discharge enters these waters. Upstream sampling location shall be located so that it is not influenced by backwater conditions and represents natural background conditions. Downstream sampling location shall be located at the point where complete mixing of the discharge and receiving water has occurred.

The discharge shall be closely monitored when water from the dewatering activities is introduced into jurisdictional wetlands. Any time visible sedimentation (deposition of sediment) on the wetland surface is observed, the dewatering activity will be suspended until turbidity levels in the stilling basin can be reduced to a level where sediment deposition does not occur. Staining of

wetland surfaces from suspended clay particles, occurring after evaporation or infiltration, does not constitute sedimentation. No activities shall occur in wetlands that adversely affect the functioning of a wetland. Visible sedimentation will be considered an indication of possible adverse impacts on wetland use.

The Engineer will perform independent turbidity tests on a random basis. These results will be maintained in a log within the project records. Records will include, at a minimum, turbidity test results, time, date and name of sampler. Should the Department's test results exceed those of the Contractor's test results, an immediate test shall be performed jointly with the results superseding the previous test results of both the Department and the Contractor.

The Contractor shall use the *NCDOT Turbidity Reduction Options for Borrow Pits Matrix*, available at [http://www.ncdot.gov/doh/operations/dp\\_chief\\_eng/roadside/fieldops/downloads/Files/TurbidityReductionOptionSheet.pdf](http://www.ncdot.gov/doh/operations/dp_chief_eng/roadside/fieldops/downloads/Files/TurbidityReductionOptionSheet.pdf) to plan, design, construct, and maintain BMPs to address water quality standards. Tier I Methods include stilling basins which are standard compensatory BMPs. Other Tier I methods are noncompensatory and shall be used when needed to meet the stream turbidity standards. Tier II Methods are also noncompensatory and are options that may be needed for protection of rare or unique resources or where special environmental conditions exist at the site which have led to additional requirements being placed in the DWQ's 401 Certifications and approval letters, Isolated Wetland Permits, Riparian Buffer Authorization or a DOT Reclamation Plan's Environmental Assessment for the specific site. Should the Contractor exhaust all Tier I Methods on a site exclusive of rare or unique resources or special environmental conditions, Tier II Methods may be required by regulators on a case by case basis per supplemental agreement.

The Contractor may use cation exchange capacity (CEC) values from proposed site borings to plan and develop the bid for the project. CEC values exceeding 15 milliequivalents per 100 grams of soil may indicate a high potential for turbidity and should be avoided when dewatering into surface water is proposed.

No additional compensation for monitoring borrow pit discharge will be paid.

**EMPLOYMENT:**

(11-15-11) (Rev. 1-17-12)

108, 102

SP1 G184

Revise the *2012 Standard Specifications* as follows:

**Page 1-20, Subarticle 102-15(O)**, delete and replace with the following:

(O) Failure to restrict a former Department employee as prohibited by Article 108-5.

**Page 1-65, Article 108-5 Character of Workmen, Methods, and Equipment, line 32**, delete all of line 32, the first sentence of the second paragraph and the first word of the second sentence of the second paragraph.

**STATE HIGHWAY ADMINISTRATOR TITLE CHANGE:**

(9-18-12)

SP1 G185

Revise the *2012 Standard Specifications* as follows:

Replace all references to “State Highway Administrator” with “Chief Engineer”.

**SUBLETTING OF CONTRACT:**

(11-18-2014)

108-6

SP1 G186

Revise the *2012 Standard Specifications* as follows:

**Page 1-66, Article 108-6 Subletting of Contract, line 37**, add the following as the second sentence of the first paragraph:

All requests to sublet work shall be submitted within 30 days of the date of availability or prior to expiration of 20% of the contract time, whichever date is later, unless otherwise approved by the Engineer.

**Page 1-67, Article 108-6 Subletting of Contract, line 7**, add the following as the second sentence of the fourth paragraph:

Purchasing materials for subcontractors is not included in the percentage of work required to be performed by the Contractor. If the Contractor sublets items of work but elects to purchase material for the subcontractor, the value of the material purchased will be included in the total dollar amount considered to have been sublet.

**PROJECT SPECIAL PROVISIONS****ROADWAY****CLEARING AND GRUBBING - METHOD III:**

(4-6-06) (Rev.8-18-15)

200

SP2 R02B

Perform clearing on this project to the limits established by Method "III" shown on Standard Drawing No. 200.03 of the *2012 Roadway Standard Drawings*. Conventional clearing methods may be used except where permit drawings or conditions have been included in the proposal which require certain areas to be cleared by hand methods.

**BURNING RESTRICTIONS:**

(7-1-95)

200, 210, 215

SP2 R05

Open burning is not permitted on any portion of the right-of-way limits established for this project. Do not burn the clearing, grubbing or demolition debris designated for disposal and generated from the project at locations within the project limits, off the project limits or at any waste or borrow sites in this county. Dispose of the clearing, grubbing and demolition debris by means other than burning, according to state or local rules and regulations.

**TEMPORARY DETOURS:**

(7-1-95) (Rev. 11-19-13)

1101

SP2 R30B

Construct temporary detours required on this project in accordance with the typical sections in the plans or as directed.

After the detours have served their purpose, remove the portions deemed unsuitable for use as a permanent part of the project as directed by the Engineer. Salvage and stockpile the aggregate base course removed from the detours at locations within the right of way, as directed by the Engineer, for removal by State Forces. Place pavement and earth material removed from the detour in embankments or dispose of in waste areas furnished by the Contractor.

Aggregate base course and earth material that is removed will be measured and will be paid at the contract unit price per cubic yard for *Unclassified Excavation*. Pavement that is removed will be measured and will be paid at the contract unit price per square yard for *Removal of Existing \_\_\_\_\_ Pavement*. Pipe culverts removed from the detours remain the property of the Contractor. Pipe culverts that are removed will be measured and will be paid at the contract unit price per linear foot for *Pipe Removal*. Payment for the construction of the detours will be made at the contract unit prices for the various items involved.

Such prices and payments will be full compensation for constructing the detours and for the work of removing, salvaging, and stockpiling aggregate base course; removing pipe culverts; and for placing earth material and pavement in embankments or disposing of earth material and pavement in waste areas.

**SHOULDER AND FILL SLOPE MATERIAL:**

(5-21-02)

235, 560

SP2 R45 B

**Description**

Perform the required shoulder and slope construction for this project in accordance with the applicable requirements of Section 560 and Section 235 of the *2012 Standard Specifications*.

**Measurement and Payment**

When the Contractor elects to obtain material from an area located beneath a proposed fill sections which does not require excavation for any reason other than to generate acceptable shoulder and fill slope material, the work of performing the excavation will be considered incidental to the item of *Borrow Excavation* or *Shoulder Borrow*. If there is no pay item for *Borrow* or *Shoulder Borrow* in the contract, this work will be considered incidental to *Unclassified Excavation*. Stockpile the excavated material in a manner to facilitate measurement by the Engineer. Fill the void created by the excavation of the shoulder and fill slope material with suitable material. Payment for material used from the stockpile will be made at the contract unit price for *Borrow Excavation* or *Shoulder Borrow*. If there is no pay item for *Borrow Excavation* or *Shoulder Borrow*, then the material will be paid for at the contract unit price for *Unclassified Excavation*. The material used to fill the void created by the excavation of the shoulder and fill slope material will be made at the contract unit price for *Unclassified Excavation*, *Borrow Excavation*, or *Shoulder Borrow*, depending on the source of the material.

Material generated from undercut excavation, unclassified excavation or clearing and grubbing operations that is placed directly on shoulders or slope areas, will not be measured separately for payment, as payment for the work requiring the excavation will be considered adequate compensation for depositing and grading the material on the shoulders or slopes.

When undercut excavation is performed at the direction of the Engineer and the material excavated is found to be suitable for use as shoulder and fill slope material, and there is no area on the project currently prepared to receive the material generated by the undercut operation, the Contractor may construct a stockpile for use as borrow at a later date. Payment for the material used from the stockpile will be made at the contract unit price for *Borrow Excavation* or *Shoulder Borrow*.

When shoulder material is obtained from borrow sources or from stockpiled material, payment for the work of shoulder construction will be made at the contract unit price per cubic yard for *Borrow Excavation* or *Shoulder Borrow* in accordance with the applicable provisions of Section 230 or Section 560 of the *2012 Standard Specifications*.

**COAL COMBUSTION PRODUCTS IN EMBANKMENTS:**

(4-16-02) (Rev. 5-19-15)

235

SP02 R70

**Description**

This specification allows the Contractor an option, with the approval of the Engineer, to use coal combustion products (CCPs) in embankments as a substitute for conventional borrow material. The amount of CCPs allowed to be used for this project will be less than 80,000 tons total and less than 8,000 tons per acre.



**Materials**

Supply coal combustion products from the Department list of potential suppliers maintained by the Value Management Unit. Site specific approval of CCP material will be required prior to beginning construction.

The following CCPs are unacceptable:

- (A) Frozen material,
- (B) Ash from boilers fired with both coal and petroleum coke, and
- (C) Material with a maximum dry unit weight of less than 65 pounds per cubic foot when tested in accordance with AASHTO T-99 Method A or C.

Collect and transport CCPs in a manner that will prevent nuisances and hazards to public health and safety. Moisture condition the CCPs as needed and transport in covered trucks to prevent dusting.

**Preconstruction Requirements**

When CCPs are to be used as a substitute for earth borrow material, request written approval from the Engineer at least ninety (90) days in advance of the intent to use CCPs and include the following details using the NCDOT Form #CCP-2015-V1 in accordance with NCGS § 130A-309.215(b)(1):

- (A) Description, purpose and location of project.
- (B) Estimated start and completion dates of project.
- (C) Estimated volume of CCPs to be used on project with specific locations and construction details of the placement.
- (D) Toxicity Characteristic Leaching Procedure analysis from a representative sample of each different CCP source to be used in the project for, at minimum, all of the following constituents: arsenic, barium, cadmium, lead, chromium, mercury, selenium, and silver.
- (E) The names, address, and contact information for the generator of the CCPs.
- (F) Physical location of the project at which the CCPs were generated.

Submit the form to the Engineer and the State Value Management Engineer at [valuemanagementunit@ncdot.gov](mailto:valuemanagementunit@ncdot.gov) for review. The Engineer and the State Value Management Engineer will coordinate the requirements of NCGS § 130A-309.215(a)(1) and notify the Contractor that all the necessary requirements have been met before the placement of structural fill using coal combustion products is allowed.

**Construction Methods**

In accordance with the detail in the plans, place CCPs in the core of the embankment section with at least 4 feet of earth cover to the outside limits of the embankments or subgrade and at least 5 feet above the seasonal high ground-water table. CCPs used in embankments shall not be placed as follows:

- (A) Within 50 feet of any property boundary.
- (B) Within 300 horizontal feet of a private dwelling or well.

- (C) Within 50 horizontal feet of the top of the bank of a perennial stream or other surface water body.
- (D) Within a 100-year floodplain except as authorized under NCGS § 143-215.54A(b). A site located in a floodplain shall not restrict the flow of the 100-year floodplain or result in washout of solid waste so as to pose a hazard to human life, wildlife or land and water resources.
- (E) Within 50 horizontal feet of a wetland, unless, after consideration of the chemical and physical impact on the wetland, the United States Army Corps of Engineers issues a permit or waiver for the fill.

Construct embankments by placing CCPs in level uniform lifts with no more than a lift of 10 inches and compacted to at least a density of 95 percent as determined by test methods in AASHTO T-99, Determination of Maximum Dry Density and Optimum Moisture Content, Method A or C depending upon particle size of the product. Provide a moisture content at the time of compaction of within 4 percent of optimum but not greater than one percent above optimum as determined by AASHTO T-99, Method A or C.

Divert surface waters resulting from precipitation from the CCPs placement area during filling and construction activities. Construct embankments such that rainfall will not run directly off of the CCPs. Provide dust control to minimize airborne emissions. Construct fill in a manner that prevents water from accumulating and ponding and do not pump nor discharge waters from CCP's filling and construction areas.

### Measurement and Payment

*Borrow Excavation* will be measured by truck volume and paid in cubic yards in accordance with Article 230-5 of the *2012 Standard Specifications*.

### **MANUFACTURED QUARRY FINES IN EMBANKMENTS:**

(01-17-17)

235

SP02 R72

#### **Description**

This specification addresses the use of manufactured quarry fines that are not classified as select materials. The specification allows the Contractor an option, with the approval of the Engineer, to use manufactured quarry fines (MQFs) in embankments as a substitute for conventional borrow material. Furnish and place geotextile for pavement stabilization in accordance with the Geotextile for Pavement Stabilization special provision and detail. Geotextile for pavement stabilization is required to prevent pavement cracking and provide separation between the subgrade and pavement section at embankment locations where manufactured quarry fines are utilized and as directed by the Engineer.

#### **Materials**

Manufactured Quarry Fines.

Site specific approval of MQFs material will be required prior to beginning construction as detailed in the preconstruction requirements of this provision.

The following MQFs are unacceptable:

- (A) Frozen material,
- (B) Material with a maximum dry unit weight of less than 90 pounds per cubic foot when tested in accordance with AASHTO T-99 Method A or C.

- (C) Material with greater than 80% by weight Passing the #200 sieve

Collect and transport MQFs in a manner that will prevent nuisances and hazards to public health and safety. Moisture condition the MQFs as needed and transport in covered trucks to prevent dusting. If MQFs are blended with natural earth material, follow Borrow Criteria in Section 1018 of the *Standard Specifications*.

Geotextiles.

Areas of embankment where MQFs are incorporated, Geotextile for Pavement Stabilization shall be used. If the Geotextile for Pavement Stabilization special provision is not included elsewhere in this contract, then it along with a detail will be incorporated as part of the contractors request to use. Notification of subgrade elevation, sampling and waiting period as required in the Construction Methods section of the Geotextile for Pavement Stabilization special provision are not required.

### **Preconstruction Requirements**

When MQFs are to be used as a substitute for earth borrow material, request written approval from the Engineer at least ninety (90) days in advance of the intent to use MQFs and include the following details:

- (A) Description, purpose and location of project.
- (B) Estimated start and completion dates of project.
- (C) Estimated volume of MQFs to be used on project with specific locations and construction details of the placement.
- (D) The names, address, and contact information for the generator of the MQFs.
- (E) Physical location of the site at which the MQFs were generated.

The Engineer will forward this information to the State Materials Engineer for review and material approval.

### **Construction Methods**

Place MQFs in the core of the embankment section with at least 4 feet of earth cover to the outside limits of the embankments or subgrade.

Construct embankments by placing MQFs in level uniform lifts with no more than a lift of 10 inches and compacted to at least a density of 95 percent as determined by test methods in AASHTO T-99, Determination of Maximum Dry Density and Optimum Moisture Content, Method A or C depending upon particle size of the product. Provide a moisture content at the time of compaction of within 4 percent of optimum but not greater than one percent above optimum as determined by AASHTO T-99, Method A or C.

Areas of embankment where MQFs are incorporated, Geotextile for Pavement Stabilization shall be used. See Geotextile for Pavement Stabilization special provision for geotextile type and construction method.

**Measurement and Payment**

*Borrow Excavation* will be measured by truck volume and paid in cubic yards in accordance with Article 230-5 of the *2012 Standard Specifications*. As an alternate weigh tickets can be provided and payment made by converting weight to cubic yards based on the verifiable unit weight.

Where the pay item of *Geotextile for Pavement Stabilization* is included in the original contract the material will be measured and paid in square yards (see *Geotextile for Pavement Stabilization* special provision). Where the pay item of *Geotextile for Pavement Stabilization* is not included in the original contract then no payment will be made for this item and will be considered incidental to the use of MQFs in embankment.

**EMBANKMENT SETTLEMENT GAUGES:**

(7-1-95) (Rev. 8-18-15)

235

SP2 R75

Revise the *2012 Standard Specifications* as follows:

**Page 2-22, Article 235-1 DESCRIPTION**, add the following:

Surcharges and waiting periods may be required for embankments and retaining walls to minimize and control the effects of settlement on structures, approach slabs, pavements, pipes, utilities, etc. Settlement gauges may be required to monitor settlement at approximate locations shown in the plans and as directed.

**Page 2-22, Article 235-2 MATERIALS**, add the following:

Provide Schedule 40 black steel pipes and couplers with steel or wood bases for settlement gauges. Use steel plates with yield strength of at least 36 ksi and pressure treated wood boards for bases of settlement gauges.

**Page 2-24, Article 235-3 CONSTRUCTION METHODS**, add the following:

**(E) Surcharges and Waiting Periods**

Place surcharges at locations shown in the plans. Unless required otherwise in the contract, surcharge embankments after embankments are constructed to the grade and cross section shown in the plans. Construct surcharges with side slopes as directed, 2:1 (H:V) end slopes outside of surcharge limits and surcharge heights shown in the plans. Place and compact surcharge material in accordance with Subarticles 235-3(B) and 235-3(C). Construct and maintain adequate drainage of surface runoff to prevent erosion of surcharge material.

Waiting period durations are in accordance with the contract and as directed. Surcharge waiting periods apply to surcharge locations shown in the plans and begin after surcharges are constructed to the height shown in the plans.

Unless required otherwise in the contract, bridge waiting periods are required in accordance with the following:

- (1) Apply to bridge embankments and retaining walls within 100 ft of end bent and bent locations shown in the plans and

- (2) Begin after bridge embankments and retaining walls are constructed to the elevations noted in the plans.

Unless required otherwise in the contract, embankment waiting periods are required in accordance with the following:

- (1) Apply to embankment locations shown in the plans and retaining walls for embankments with waiting periods and
- (2) Begin after embankments and retaining walls are constructed to the elevations, grade and cross section shown in the plans.

Except for maintaining embankments, do not perform any work on embankments or structures with waiting periods until waiting periods end unless otherwise approved. Place and compact additional material in accordance with Subarticles 235-3(B) and 235-3(C) to maintain embankment grade elevations during waiting periods. Remove surcharges to the grade and cross section shown in the plans after surcharge waiting periods end.

**(F) Embankment Monitoring**

Fabricate and install settlement gauges in accordance with the contract. Make settlement gauges highly visible so gauges are not disturbed while monitoring settlement. Use only hand operated compaction equipment to compact fill material around gauges.

Do not damage settlement gauges. Damaged settlement gauges may require replacement or additional gauges and waiting period extensions as determined by the Engineer.

**Page 2-24, Article 235-5 MEASUREMENT AND PAYMENT**, add the following:

*Borrow Excavation* for surcharge material and additional material for maintaining embankment grade elevations will be measured and paid in accordance with Article 230-5. *Unclassified Excavation* for surcharge material, additional material for maintaining embankment grade elevations and removing surcharges will be measured and paid in accordance with Article 225-7. When there is no pay item for *Borrow Excavation* or *Unclassified Excavation* in the contract, surcharge material and removing surcharges will be included in the lump sum payment for *Grading*. Additional material for maintaining embankment grade elevations will be paid as extra work in accordance with Article 104-7.

*Embankment Settlement Gauges* will be measured and paid in units of each. Settlement gauges will be measured as one per gauge location. The contract unit price for *Embankment Settlement Gauges* will be full compensation for fabricating and installing settlement gauges including placing and compacting fill material around gauges, adding pipes and couplers until embankment monitoring ends and any incidentals necessary to monitor settlement. No payment will be made for interfering with the Contractor's operations due to embankment monitoring or damaged settlement gauges as determined by the Engineer.

Payment will be made under:

<b>Pay Item</b>	<b>Pay Unit</b>
Embankment Settlement Gauges	Each

**ROCK AND BROKEN PAVEMENT FILLS:**

(2-16-16)

235

SP2 R85

Revise the *2012 Standard Specifications* as follows:

**Page 2-22, Article 235-2 MATERIALS**, add the following after line 19:

<b>Item</b>	<b>Section</b>
Geotextile for Rock and Broken Pavement Fills, Type 2	1056

Provide Type 2 geotextile for filtration geotextiles. Use rip rap and No. 57 stone from either a quarry or onsite material to fill voids in rock and broken pavement fills. Provide small and large size rip rap with stone sizes that meet Class A and B in accordance with Table 1042-1 and No. 57 stone with a gradation that meets Table 1005-1 or use similar size onsite material approved by the Engineer.

**Page 2-23, Subarticle 235-3(B) Embankment Formation**, lines 18-19, delete the third sentence in the seventh paragraph.

**Page 2-23, Subarticle 235-3(B) Embankment Formation**, lines 21-23, replace the eighth paragraph with the following:

Before placing embankment fill material or filtration geotextiles over rock and broken pavement, fill voids in the top of rock and broken pavement fill with rip rap and No. 57 stone. Place and compact larger rip rap first followed by smaller rip rap. Then, fill any remaining voids with No. 57 stone so geotextiles are not torn, ripped or otherwise damaged when installed and covered. Compact rip rap and No. 57 stone with tracked equipment or other approved methods. Install filtration geotextiles on top of rock, broken pavement, rip rap and No. 57 stone in accordance with Article 270-3 before placing remaining embankment fill material.

Remove any rocks, debris or pavement pieces from the roadbed larger than 2" within 12" of the subgrade or finished grade, whichever is lower.

**Page 2-24, Article 235-5 MEASUREMENT AND PAYMENT**, line 13, add the following to the end of the first paragraph:

Payment for rip rap, No. 57 stone and geotextiles to construct embankments with rock and broken pavement fills will be considered incidental to the work in Sections 225, 226, 230 and 240.

**BLASTING:**

(2-16-16)

220

SP2 R88B

Revise the *2012 Standard Specifications* as follows:

**Page 2-8, Article 220-1 DESCRIPTION**, line 22, delete “cushion, ”.

**Page 2-8, Article 220-1 DESCRIPTION**, line 23, add the following after the third sentence:

Unless required otherwise in the contract, design blasts for the vibration and air overpressure limits in this section.

**Page 2-9, Subarticle 220-3(A) Vibration and Air Overpressure Limits**, line 18, add the following to the end of Subarticle 220-3(A):

Unless required otherwise in the contract or directed, design production and trench blasts in accordance with the following:

- (1) Production Blasting
  - (a) For rock cut slopes steeper than 1.5:1 (H:V) without pre-splitting, do not use production blast holes more than 4" in diameter within 10 ft of finished slope faces or neat lines
  - (b) Do not drill production holes below bottom of adjacent pre-split blast holes
  - (c) Use delay blasting to detonate production blast holes towards a free face
- (2) Trench Blasting
  - (a) Do not use trench blast holes more than 3" in diameter
  - (b) Do not use ANFO or other bulk loaded products
  - (c) Use cartridge explosives or other explosive types designed for trench blasting
  - (d) Use charges with a diameter of 1/2" to 3/4" less than the trench blast hole diameter

**PIPE INSTALLATION:**

(11-20-12) (Rev. 8-18-15)

300

SP3 R01

Revise the *2012 Standard Specifications* as follows:

**Page 3-1, Article 300-2, Materials**, line 15, in the materials table, replace “Flowable Fill” and “Geotextiles” with the following:

<b>Item</b>	<b>Section</b>
Flowable Fill, Excavatable	1000-6
Grout, Type 2	1003
Geotextiles, Type 4	1056

**Page 3-1, Article 300-2, Materials**, lines 23-24, replace sentence with the following:

Provide foundation conditioning geotextile and geotextile to wrap pipe joints in accordance with Section 1056 for Type 4 geotextile.

**Page 3-3, Subarticle 300-6(A), Rigid Pipe**, line 2, in the first paragraph, replace “an approved non-shrink grout.” with “grout.” and line 4, in the second paragraph, replace “filtration geotextile” with “geotextile”.

**Page 3-3, Article 300-7, Backfilling**, lines 37-38, in the first and second sentences of the fifth paragraph, replace “Excavatable flowable fill” with “Flowable fill”.

**FLOWABLE FILL:**

(9-17-02) (Rev 1-17-12)

300, 340, 1000, 1530, 1540, 1550

SP3 R30

**Description**

This work consists of all work necessary to place flowable fill in accordance with these provisions, the plans, and as directed.

**Materials**

Refer to Division 10 of the *2012 Standard Specifications*.

**Item**

Flowable Fill

**Section**

1000-6

**Construction Methods**

Discharge flowable fill material directly from the truck into the space to be filled, or by other approved methods. The mix may be placed full depth or in lifts as site conditions dictate. The Contractor shall provide a method to plug the ends of the existing pipe in order to contain the flowable fill.

**Measurement and Payment**

At locations where flowable fill is called for on the plans and a pay item for flowable fill is included in the contract, *Flowable Fill* will be measured in cubic yards and paid as the actual number of cubic yards that have been satisfactorily placed and accepted. Such price and payment will be full compensation for all work covered by this provision including, but not limited to, the mix design, furnishing, hauling, placing and containing the flowable fill.

Payment will be made under:

**Pay Item**

Flowable Fill

**Pay Unit**

Cubic Yard

**BRIDGE APPROACH FILLS:**

(10-19-10) (Rev. 1-17-12)

422

SP4 R02

**Description**

Bridge approach fills include bridge approach fills for sub regional tier bridges and reinforced bridge approach fills. Construct bridge approach fills in accordance with the contract and Standard Drawing No. 422.10 or 422.11 of the *2012 Roadway Standard Drawings*. Define “geosynthetics”



as geotextiles or geomembranes.

## **Materials**

Refer to Division 10 of the *2012 Standard Specifications*.

<b>Item</b>	<b>Section</b>
Anchor Pins	1056-2
Geotextiles	1056
Portland Cement Concrete	1000
Select Material	1016
Subsurface Drainage Materials	1044
Wire Staples	1060-8(D)

For bridge approach fills for sub regional tier bridges, provide Type 1 geotextile for filtration geotextiles. For reinforced bridge approach fills, provide Type 5 geotextile for geotextile reinforcement and Type 1 geotextile and No. 78M stone for drains. Use Class B concrete for concrete pads.

Use Class III or V select material for reinforced bridge approach fills and only Class V select material (standard size No. 78M stone) for bridge approach fills for sub regional tier bridges. Provide PVC pipes, fittings and outlet pipes for subsurface drainage materials. For drains and PVC pipes behind end bents, use pipes with perforations that meet AASHTO M 278.

Use PVC, HDPE or linear low density polyethylene (LLDPE) geomembranes for reinforced bridge approach fills. For PVC geomembranes, provide grade PVC30 geomembranes that meet ASTM D7176. For HDPE and LLDPE geomembranes, use geomembranes with a nominal thickness of at least 30 mils that meet Geosynthetic Research Institute Standard Specifications GM13 or GM17, respectively. Handle and store geomembranes in accordance with Article 1056-2 of the *2012 Standard Specifications*. Provide material certifications for geomembranes in accordance with Article 1056-3 of the *2012 Standard Specifications*.

## **Construction Methods**

Excavate as necessary for bridge approach fills in accordance with the contract. Notify the Engineer when foundation excavation is complete. Do not place geomembranes or filtration geotextiles until excavation dimensions and foundation material are approved. Attach geomembranes and filtration geotextiles to end bent cap back and wing walls with adhesives, tapes or other approved methods. Glue or weld geomembrane seams to prevent leakage.

For reinforced bridge approach fills, place geotextile reinforcement within 3" of locations shown in Standard Drawing No. 422.10 of the *2012 Roadway Standard Drawings* and in slight tension free of kinks, folds, wrinkles or creases. Install geotextile reinforcement with the orientation, dimensions and number of layers shown in Standard Drawing No. 422.10 of the *2012 Roadway Standard Drawings*. Place first layer of geotextile reinforcement directly on geomembranes with no void or material in between. Install geotextile reinforcement with the machine direction (MD) parallel to the roadway centerline. The MD is the direction of the length or long dimension of the geotextile roll. Do not splice or overlap geotextile reinforcement in the MD so seams are

perpendicular to the roadway centerline. Wrap geotextile reinforcement at end bent cap back and wing walls as shown in Standard Drawing No. 422.10 of the *2012 Roadway Standard Drawings* and directed by the Engineer. Extend geotextile reinforcement at least 4 ft back behind end bent cap back and wing walls into select material.

Overlap adjacent geotextiles at least 18" with seams oriented parallel to the roadway centerline. Hold geotextiles in place with wire staples or anchor pins as needed. Contact the Engineer when existing or future obstructions such as foundations, pavements, pipes, inlets or utilities will interfere with geosynthetics.

For reinforced bridge approach fills, construct one foot square drains consisting of 4" diameter continuous perforated PVC pipes surrounded by No. 78M stone wrapped in Type 1 geotextiles. Install drains in accordance with Standard Drawing No. 422.10 of the *2012 Roadway Standard Drawings*. For bridge approach fills for sub regional tier bridges, install 4" diameter continuous perforated PVC drain pipes in accordance with Standard Drawing No. 422.11 of the *2012 Roadway Standard Drawings*.

Use solvent cement to connect PVC pipes so joints do not leak. Connect perforated pipes to outlet pipes just behind wing walls. Provide drain pipes and drains with positive drainage towards outlets. Place pipe sleeves in or under wing walls for outlet pipes so positive drainage is maintained. Use sleeves that can withstand wing wall loads.

Place select material in 8" to 10" thick lifts. Use only hand operated compaction equipment to compact select material for bridge approach fills. Compact Class III select material in accordance with Subarticle 235-3(C) of the *2012 Standard Specifications*. Compact No. 78M stone with a vibratory compactor to the satisfaction of the Engineer. Do not displace or damage geosynthetics, drain pipes or drains when placing and compacting select material. End dumping directly on geosynthetics is not permitted. Do not operate heavy equipment on geosynthetics, drain pipes or drains until they are covered with at least 8" of select material. Replace any damaged geosynthetics, drain pipes or drains to the satisfaction of the Engineer.

Cover open ends of outlet pipes with rodent screens as shown in Standard Drawing No. 815.03 of the *2012 Roadway Standard Drawings*. Connect ends of outlet pipes to concrete pads or existing drainage structures as directed by the Engineer. Construct concrete pads with an Ordinary surface finish that meets Subarticle 825-6(B) of the *2012 Standard Specifications*.

### **Measurement and Payment**

*Reinforced Bridge Approach Fill, Station \_\_\_\_* will be paid at the contract lump sum price. The contract lump sum price for *Reinforced Bridge Approach Fill, Station \_\_\_\_* will be full compensation for labor, tools, equipment and reinforced bridge approach fill materials, excavating, backfilling, hauling and removing excavated materials, compacting select material, connecting outlet pipes to existing drainage structures and supplying select materials, geosynthetics, drains, pipe sleeves and outlet components and any incidentals necessary to construct all reinforced bridge approach fills at each bridge.

*Bridge Approach Fill - Sub Regional Tier, Station \_\_\_\_* will be paid at the contract lump sum price. The contract lump sum price for *Bridge Approach Fill - Sub Regional Tier, Station \_\_\_\_*

will be full compensation for labor, tools, equipment and bridge approach fill materials, excavating, backfilling, hauling and removing excavated materials, compacting No. 78M stone, connecting outlet pipes to existing drainage structures and supplying No. 78M stone, filtration geotextiles, drain pipes, pipe sleeves and outlet components and any incidentals necessary to construct all bridge approach fills at each sub regional tier bridge.

Payment will be made under:

**Pay Item**

Reinforced Bridge Approach Fill, Station \_\_\_\_  
 Bridge Approach Fill - Sub Regional Tier, Station \_\_\_\_

**Pay Unit**

Lump Sum  
 Lump Sum

**PREPARATION OF SUBGRADE AND BASE:**

(1-16-96)

610

SP5 R05

On mainline portions and ramps of this project, prepare the subgrade and base beneath the pavement structure in accordance with the applicable sections of the *2012 Standard Specifications* except use an automatically controlled fine grading machine using string lines, laser controls or other approved methods to produce final subgrade and base surfaces meeting the lines, grades and cross sections required by the plans or established by the Engineer.

No direct payment will be made for the work required by this provision as it will be considered incidental to other work being paid for by the various items in the contract.

**AUTOMATED MACHINE GUIDANCE**

(1-2-11)

SPI 5-05

**General**

This Special Provision contains requirements to be followed if the Contractor elects to use Global Positioning System (GPS) machine control grading and shall be used in conjunction with Section 801 of the *Standard Specifications*. The use of this technology is referenced as Automated Machine Guidance (AMG).

All equipment using AMG shall be able to generate end results that meet the *Standard Specifications*. Perform test sections for each type of work to be completed with AMG to demonstrate that the system has the capability to achieve acceptable results. If acceptable results cannot be achieved, conform to the requirements for conventional stakeout.

The Contractor shall be responsible for all errors resulting from the use of AMG and shall correct deficiencies to the satisfaction of the Engineer at no cost to the Department.

**Submittals**

If the Contractor elects to use AMG, a Digital Terrain Model (DTM) of the design surface and all intermediate surfaces shall be developed and submitted to the Engineer for review.

At least 90 days prior to beginning grading operations, the Contractor shall submit to the Engineer an AMG work plan to include, but not limited to, proposed equipment, control software

manufacturer and version, types of work to be completed using AMG, project site calibration report, repetitive calibration methods for construction equipment and rover units to be used for the duration of the project, and local GPS base station to be used for broadcasting differential correction data to rover units (this may include the NC Network RTK). All surveys must be tied to existing project control as established by NCDOT.

**Inspection**

The Engineer will perform quality assurance checks of all work associated with AMG. If it is determined that work is not being performed in a manner that will assure accurate results, the Engineer may require corrective action at no cost to the Department.

The Contractor shall provide the Engineer with one GPS rover unit for use during the duration of the contract. The rover will be loaded with the same model that is used with the AMG and have the same capability as rover units used by the Contractor. The rover will be kept in the possession of the Engineer and will be returned to the Contractor upon completion of the contract. Any maintenance or repairs required for the rover will be the responsibility of the Contractor. Formal training of at least 8 hours shall be provided to the Engineer by the Contractor on the use of the proposed AMG system.

**Subgrade and Base Controls**

If the Contractor elects to use AMG for fine grading and placement of base or other roadway materials, the GPS shall be supplemented with a laser or robotic total station. Include details of the proposed system in the AMG work plan. In addition, the following requirements apply for the use of AMG for subgrade and base construction.

Provide control points at intervals along the project not to exceed 1,000 feet. The horizontal position of these points shall be determined by static GPS sessions or by traverse connection from the original base line control points. The elevation of these control points shall be established using differential leveling from project benchmarks, forming closed loops where practical. A copy of all new control point information shall be provided to the Engineer prior to construction activities.

Provide control points and conventional survey grade stakes at 500 foot intervals and at critical points such as, but not limited to, PCs, PTs, superelevation transition points, and other critical points as requested by the Engineer.

Provide hubs at the top of the finished subgrade at all hinge points on the cross section at 500 foot intervals. These hubs shall be established using conventional survey methods for use by the Engineer to check the accuracy of construction.

**Measurement and Payment**

No direct payment will be made for work required to utilize this provision. All work will be considered incidental to various grading operations.

**CLASS IV SUBGRADE STABILIZATION IN LIEU OF CHEMICAL STABILIZATION:**

(6-16-15)

501, 542

SP05 R017

**Description**

In lieu of chemical stabilization, provide Class IV Subgrade Stabilization by replacing 8" of subgrade soils with geotextile and Class IV select material. This substitution is allowed in full typical section width and cannot result in chemically stabilized sections less than 1,000 feet in length, unless otherwise approved by the Engineer. Notify the Engineer at least 30 days in advance of starting Class IV Subgrade Stabilization in lieu of Chemical Stabilization.

**Materials**

Refer to the *2012 Standard Specifications*.

<b>Item</b>	<b>Section</b>
Geotextile for Soil Stabilization, Type 4	1056
Select Material, Class IV	1016

Use Class IV Select Material for Class IV Subgrade Stabilization.

**Construction Methods**

Install geotextile for soil stabilization in accordance with Article 270-3 in the *2012 Standard Specifications*. Place Class IV subgrade stabilization (standard size no. ABC) by end dumping ABC on geotextiles. Do not operate heavy equipment on geotextiles until geotextiles are covered with Class IV subgrade stabilization. Compact ABC to 97% of AASHTO T 180 as modified by the Department.

Maintain Class IV subgrade stabilization in an acceptable condition and minimize the use of heavy equipment on ABC in order to avoid damaging aggregate subgrades. Provide and maintain drainage ditches and drains as required to prevent entrapping water in aggregate subgrades.

**Measurement and Payment**

*Class IV Subgrade Stabilization in Lieu of Chemical Stabilization* will be paid at the prices established in the contract that relate to the chemical stabilization type that is being replaced (Lime or Cement). No direct payment will be made for additional excavation required to accommodate this alternate.

The total amount paid for this subgrade stabilization alternative will be limited to the contract amounts per square yard for replacement for Portland cement or lime, theoretical tons of Portland cement or lime replaced, mixing of cement or lime, and theoretical gallons of asphalt curing seal replaced at the rate of 0.15 gallons per square yard.

A Supplement Agreement will be executed prior to starting the work to create a square yard price for the *Class IV Subgrade Stabilization in Lieu of Chemical Stabilization* and deleting the quantities associated with the work being replaced.

**ASPHALT PAVEMENTS - SUPERPAVE:**

(6-19-12) (Rev. 8-16-16)

605, 609, 610, 650

SP6 R01

Revise the 2012 *Standard Specifications* as follows:

**Page 6-3, Article 605-7, APPLICATION RATES AND TEMPERATURES**, replace this article, including Table 605-1, with the following:

Apply tack coat uniformly across the existing surface at target application rates shown in Table 605-1.

<b>TABLE 605-1 APPLICATION RATES FOR TACK COAT</b>	
<b>Existing Surface</b>	<b>Target Rate (gal/sy)</b>
	<b>Emulsified Asphalt</b>
New Asphalt	0.04 ± 0.01
Oxidized or Milled Asphalt	0.06 ± 0.01
Concrete	0.08 ± 0.01

Apply tack coat at a temperature within the ranges shown in Table 605-2. Tack coat shall not be overheated during storage, transport or at application.

<b>TABLE 605-2 APPLICATION TEMPERATURE FOR TACK COAT</b>	
<b>Asphalt Material</b>	<b>Temperature Range</b>
Asphalt Binder, Grade PG 64-22	350 - 400°F
Emulsified Asphalt, Grade RS-1H	130 - 160°F
Emulsified Asphalt, Grade CRS-1	130 - 160°F
Emulsified Asphalt, Grade CRS-1H	130 - 160°F
Emulsified Asphalt, Grade HFMS-1	130 - 160°F
Emulsified Asphalt, Grade CRS-2	130 - 160°F

**Page 6-6, Subarticle 607-5(A), Milled Asphalt Pavement**, line 25, add the following to the end of the paragraph:

Areas to be paid under these items include mainline, turn lanes, shoulders, and other areas milled in conjunction with the mainline and any additional equipment necessary to remove pavement in the area of manholes, water valves, curb, gutter and other obstructions.

**Page 6-6, Subarticle 607-5(C), Incidental Milling**, lines 42-48, replace the paragraph with the following:

*Incidental Milling* to be paid will be the actual number of square yards of surface milled where the Contractor is required to mill butt joints, irregular areas and intersections milled as a separate operation from mainline milling and re-mill areas that are not due to the Contractor's negligence whose length is less than 100 feet. Measurement will be made as provided in Subarticle 607-5(A) for each cut the Contractor is directed to perform. Where the Contractor elects to make multiple cuts to achieve the final depth, no additional measurement will be made. Compensation will be made at the contract unit price per square yard for *Incidental Milling*.

**Page 6-7, Article 609-3, FIELD VERIFICATION OF MIXTURE AND JOB MIX FORMULA ADJUSTMENTS**, lines 35-37, delete the second sentence of the second paragraph.

**Page 6-18, Article 610-1 DESCRIPTION**, lines 40-41, delete the last sentence of the last paragraph.

**Page 6-19, Subarticle 610-3(A), Mix Design-General**, line 5, add the following as the first paragraph:

Warm mix asphalt (WMA) is allowed for use at the Contractor's option in accordance with the NCDOT Approved Products List for WMA Technologies available at:

**<https://connect.ncdot.gov/resources/Materials/MaterialsResources/Warm%20Mix%20Asphalt%20Approved%20List.pdf>**

**Page 6-20, Subarticle 610-3(C), Job Mix Formula (JMF)**, lines 47-48, replace the last sentence of the third paragraph with the following:

The JMF mix temperature shall be within the ranges shown in Table 610-1 unless otherwise approved.

**Page 6-21, Subarticle 610-3(C) Job Mix Formula (JMF)**, replace Table 610-1 with the following:

<b>TABLE 610-1 MIXING TEMPERATURE AT THE ASPHALT PLANT</b>	
<b>Binder Grade</b>	<b>JMF Mix Temperature</b>
PG 58-28; PG 64-22	250 - 290°F
PG 70-22	275- 305°F
PG 76-22	300- 325°F

**Page 6-21, Subarticle 610-3(C) Job Mix Formula (JMF)**, lines 1-2, in the first sentence of the first paragraph, delete "and compaction". Lines 4-7, delete the second paragraph and replace with the following:

When RAS is used, the JMF mix temperature shall be established at 275°F or higher.

**Page 6-22, Article 610-4, WEATHER, TEMPERATURE AND SEASONAL LIMITATIONS FOR PRODUCING AND PLACING ASPHALT MIXTURES**, lines 15-17, replace the second sentence of the first paragraph with the following:

Do not place asphalt material when the air or surface temperatures, measured at the location of the paving operation away from artificial heat, do not meet Table 610-5.

**Page 6-23, Article 610-4, WEATHER, TEMPERATURE AND SEASONAL LIMITATIONS FOR PRODUCING AND PLACING ASPHALT MIXTURES**, replace Table 610-5 with the following:

<b>Asphalt Concrete Mix Type</b>	<b>Minimum Surface and Air Temperature</b>
B25.0B, C	35°F
I19.0B, C, D	35°F
SF9.5A, S9.5B	40°F <sup>A</sup>
S9.5C, S12.5C	45°F <sup>A</sup>
S9.5D, S12.5D	50°F

- A. For the final layer of surface mixes containing recycled asphalt shingles (RAS), the minimum surface and air temperature shall be 50°F.

**Page 6-23, Subarticle 610-5(A), General, lines 33-34,** replace the last sentence of the third paragraph with the following:

Produce the mixture at the asphalt plant within  $\pm 25$  °F of the JMF mix temperature. The temperature of the mixture, when discharged from the mixer, shall not exceed 350°F.

**Page 6-26, Article 610-7, HAULING OF ASPHALT MIXTURE, lines 22-23,** in the fourth sentence of the first paragraph replace “so as to overlap the top of the truck bed and” with “to”. Line 28, in the last paragraph, replace “+15 °F to -25 °F of the specified JMF temperature.” with “ $\pm 25$  °F of the specified JMF mix temperature.”

**Page 6-26, Article 610-8, SPREADING AND FINISHING, line 34,** add the following new paragraph:

As referenced in Section 9.6.3 of the *HMA/QMS Manual*, use the automatic screed controls on the paver to control the longitudinal profile. Where approved by the Engineer, the Contractor has the option to use either a fixed or mobile string line.

**Page 6-29, Article 610-13, FINAL SURFACE TESTING AND ACCEPTANCE, line 39,** add the following after the first sentence in the first paragraph:

Smoothness acceptance testing using the inertial profiler is not required on ramps, loops and turn lanes.

**Page 6-30, Subarticle 610-13(A), Option 1 – Inertial Profiler, lines 15-16,** replace the fourth sentence of the fourth paragraph with the following:

The interval at which relative profile elevations are reported shall be 2”.



**Page 6-30, Subarticle 610-13(A), Option 1 – Inertial Profiler, lines 25-28,** replace the ninth paragraph with the following:

Operate the profiler at any speed as per the manufacturer’s recommendations to collect valid data.

**Page 6-30, Subarticle 610-13(A), Option 1 – Inertial Profiler, lines 30-31,** delete the third sentence of the tenth paragraph.

**Page 6-31, Subarticle 610-13(A), Option 1 – Inertial Profiler, lines 11-13,** replace the first sentence of the third paragraph with the following:

After testing, transfer the profile data from the profiler portable computer’s hard drive to a write once storage media (Flash drive, USB, DVD-R or CD-R) or electronic media approved by the Engineer.

**Page 6-31, Subarticle 610-13(A), Option 1 – Inertial Profiler, lines 17-18,** replace the first sentence of the fourth paragraph with the following:

Submit a report with the documentation and electronic data of the evaluation for each section to the Engineer within 10 days after completion of the smoothness testing. The report shall be in the tabular format for each 0.10 segment or a portion thereof with a summary of the MRI values and the localized roughness areas including corresponding project station numbers or acceptable reference points. Calculate the pay adjustments for all segments in accordance with the formulas in Sections (1) and (2) shown below. The Engineer shall review and approval all pay adjustments unless corrective action is required.

**Page 6-31, Subarticle 610-13(A)(1), Acceptance for New Construction, lines 36-37,** replace the third paragraph with the following:

The price adjustment will apply to each 0.10-mile section or prorated for a portion thereof, based on the Mean Roughness Index (MRI), the average IRI values from both wheel paths.

**Page 6-32, Subarticle 610-13(A)(2), Localized Roughness, lines 12-16,** replace the first paragraph with the following:

Areas of localized roughness shall be identified through the “Smoothness Assurance Module (SAM)” provided in the ProVAL software. Use the SAM report to optimize repair strategies by analyzing the measurements from profiles collected using inertial profilers. The ride quality threshold for localized roughness shall be 165 in/mile for any sections that are 15 ft. to 100 ft. in length at the continuous short interval of 25 ft. Submit a continuous roughness report to identify each section with project station numbers or reference points outside the threshold and identify all localized roughness, with the signature of the Operator included with the submitted IRI trace and electronic files.

**Page 6-32, Subarticle 610-13(A)(2), Localized Roughness, line 21,** add the following new paragraph:

If the Engineer does not require corrective action, the pay adjustment for each area of localized roughness shall be based on the following formula:

$$PA = (165 - LR\#) 5$$

Where:

$$PA = \text{Pay Adjustment (dollars)}$$

$$LR\# = \text{The Localized Roughness number determined from SAM report for the ride quality threshold}$$

**Page 6-41, Subarticle 650-3(B), Mix Design Criteria**, replace Table 650-1 with the following:

<b>TABLE 650-1 OGAFC GRADATION CRITERIA</b>			
<i>Sieve Size (mm)</i>	<i>Type FC-1</i>	<i>Type FC-1 Modified</i>	<i>Type FC-2 Modified</i>
19.0	-	-	100
12.5	100	100	80 - 100
9.50	75 - 100	75 - 100	55 - 80
4.75	25 - 45	25 - 45	15 - 30
2.36	5 - 15	5 - 15	5 - 15
0.075	1.0 - 3.0	1.0 - 3.0	2.0 - 4.0

**ASPHALT BINDER CONTENT OF ASPHALT PLANT MIXES:**

(11-21-00) (Rev. 7-17-12)

609

SP6 R15

The approximate asphalt binder content of the asphalt concrete plant mixtures used on this project will be as follows:

Asphalt Concrete Base Course	Type B 25.0__	4.4%
Asphalt Concrete Intermediate Course	Type I 19.0__	4.8%
Asphalt Concrete Surface Course	Type S 4.75A	6.8%
Asphalt Concrete Surface Course	Type SA-1	6.8%
Asphalt Concrete Surface Course	Type SF 9.5A	6.7%
Asphalt Concrete Surface Course	Type S 9.5__	6.0%
Asphalt Concrete Surface Course	Type S 12.5__	5.6%

The actual asphalt binder content will be established during construction by the Engineer within the limits established in the *2012 Standard Specifications*.

**ASPHALT PLANT MIXTURES:**

(7-1-95)

609

SP6 R20

Place asphalt concrete base course material in trench sections with asphalt pavement spreaders made for the purpose or with other equipment approved by the Engineer.

**PRICE ADJUSTMENT - ASPHALT BINDER FOR PLANT MIX:**

(11-21-00)

620

SP6 R25

Price adjustments for asphalt binder for plant mix will be made in accordance with Section 620 of the *2012 Standard Specifications*.

The base price index for asphalt binder for plant mix is \$ **366.00** per ton.

This base price index represents an average of F.O.B. selling prices of asphalt binder at supplier's terminals on **August 1, 2017**.

**SLUICE GATE:**

(7-1-95) (Rev. 3-17-09)

838

SP8 R20

**Description**

This work consists of the construction of a sluice gate on an endwall in accordance with the details in the plans, the applicable requirements of Section 838 of the *2012 Standard Specifications*, in accordance with the manufacturer's recommendations and as directed by the Engineer.

**Materials**

Sluice gates shall meet the manufacturer's recommendations for the corresponding pipe size. Due to variations in individual manufacturer's products, a slight variation from the size specified may be allowed. Submit the proposed catalog cut to the Engineer for approval prior to use.

**Construction Methods**

Provide a gate that forms a watertight seal when closed.

**Measurement and Payment**

\_\_\_\_ " *Sluice Gate* will be measured and paid as each for the actual number of sluice gates incorporated into the completed and accepted work. Such prices and payment will be full compensation for all materials, labor, tools, equipment and incidentals necessary to complete the work.

The endwall will be measured and paid in accordance with Article 838-4 of the *2012 Standard Specifications*.

Payment will be made under:

**Pay Item**

\_\_\_\_ " Sluice Gate

**Pay Unit**

Each

**GUARDRAIL END UNITS, TYPE - TL-2:**

(10-21-08) (Rev. 7-1-17)

862

SP8 R64

**Description**

Furnish and install guardrail end units in accordance with the details in the plans, the applicable requirements of Section 862 of the *2012 Standard Specifications*, and at locations shown in the plans.

**Materials**

Furnish guardrail end units listed on the NCDOT Approved Products List at <https://apps.dot.state.nc.us/vendor/approvedproducts/> or approved equal.

Prior to installation the Contractor shall submit to the Engineer:

- (A) FHWA acceptance letter for each guardrail end unit certifying it meets the requirements of the AASHTO Manual for Assessing Safety Hardware, Test Level 2 in accordance with Article 106-2 of the *2012 Standard Specifications*.
- (B) Certified working drawings and assembling instructions from the manufacturer for each guardrail end unit in accordance with Article 105-2 of the *2012 Standard Specifications*.

No modifications shall be made to the guardrail end unit without the express written permission from the manufacturer. Perform installation in accordance with the details in the plans, and details and assembling instructions furnished by the manufacturer.

**Construction Methods**

Guardrail end delineation is required on all approach and trailing end sections for both temporary and permanent installations. Guardrail end delineation consists of yellow reflective sheeting applied to the entire end section of the guardrail in accordance with Article 1088-3 of the *2012 Standard Specifications* and is incidental to the cost of the guardrail end unit.

**Measurement and Payment**

Measurement and payment will be made in accordance with Article 862-6 of the *2012 Standard Specifications*.

Payment will be made under:

**Pay Item**

Guardrail End Units, Type TL-2

**Pay Unit**

Each

**GUARDRAIL END UNITS, TYPE - TL-3:**

(4-20-04) (Rev. 7-1-17)

862

SP8 R65

**Description**

Furnish and install guardrail end units in accordance with the details in the plans, the applicable requirements of Section 862 of the *2012 Standard Specifications*, and at locations shown in the plans.

**Materials**

Furnish guardrail end units listed on the NCDOT Approved Products List at <https://apps.dot.state.nc.us/vendor/approvedproducts/> or approved equal.

Prior to installation the Contractor shall submit to the Engineer:

- (A) FHWA acceptance letter for each guardrail end unit certifying it meets the requirements of the AASHTO Manual for Assessing Safety Hardware, Test Level 3, in accordance with Article 106-2 of the *2012 Standard Specifications*.
- (B) Certified working drawings and assembling instructions from the manufacturer for each guardrail end unit in accordance with Article 105-2 of the *2012 Standard Specifications*.

No modifications shall be made to the guardrail end unit without the express written permission from the manufacturer. Perform installation in accordance with the details in the plans, and details and assembling instructions furnished by the manufacturer.

### **Construction Methods**

Guardrail end delineation is required on all approach and trailing end sections for both temporary and permanent installations. Guardrail end delineation consists of yellow reflective sheeting applied to the entire end section of the guardrail in accordance with Article 1088-3 of the *2012 Standard Specifications* and is incidental to the cost of the guardrail end unit.

### **Measurement and Payment**

Measurement and payment will be made in accordance with Article 862-6 of the *2012 Standard Specifications*.

Payment will be made under:

<b>Pay Item</b>	<b>Pay Unit</b>
Guardrail End Units, Type TL-3	Each

### **FOUNDATIONS AND ANCHOR ROD ASSEMBLIES FOR METAL POLES:**

(1-17-12) (Rev. 5-19-15)

9, 14, 17

SP9 R05

### **Description**

Foundations for metal poles include foundations for signals, cameras, overhead and dynamic message signs (DMS) and high mount and low level light standards supported by metal poles or upright trusses. Foundations consist of footings with pedestals and drilled piers with or without grade beams or wings. Anchor rod assemblies consist of anchor rods (also called anchor bolts) with nuts and washers on the exposed ends of rods and nuts and a plate or washers on the other ends of rods embedded in the foundation.

Construct concrete foundations with the required resistances and dimensions and install anchor rod assemblies in accordance with the contract and accepted submittals. Construct drilled piers consisting of cast-in-place reinforced concrete cylindrical sections in excavated holes. Provide temporary casings or polymer slurry as needed to stabilize drilled pier excavations. Use a prequalified Drilled Pier Contractor to construct drilled piers for metal poles. Define "excavation" and "hole" as a drilled pier excavation and "pier" as a drilled pier.

This provision does not apply to materials and anchor rod assemblies for standard foundations for low level light standards. See Section 1405 of the *2012 Standard Specifications* and Standard Drawing No. 1405.01 of the *2012 Roadway Standard Drawings* for materials and anchor rod assemblies for standard foundations. For construction of standard foundations for low level light standards, standard foundations are considered footings in this provision.

This provision does not apply to foundations for signal pedestals; see Section 1743 of the *2012 Standard Specifications* and Standard Drawing No. 1743.01 of the *2012 Roadway Standard Drawings*.

### **Materials**

Refer to the *2012 Standard Specifications*.

<b>Item</b>	<b>Section</b>
Conduit	1091-3
Grout, Type 2	1003
Polymer Slurry	411-2(B)
Portland Cement Concrete	1000
Reinforcing Steel	1070
Rollers and Chairs	411-2(C)
Temporary Casings	411-2(A)

Provide Type 3 material certifications in accordance with Article 106-3 of the *2012 Standard Specifications* for conduit, rollers, chairs and anchor rod assemblies. Store steel materials on blocking at least 12" above the ground and protect it at all times from damage; and when placing in the work make sure it is free from dirt, dust, loose mill scale, loose rust, paint, oil or other foreign materials. Load, transport, unload and store foundation and anchor rod assembly materials so materials are kept clean and free of damage. Bent, damaged or defective materials will be rejected.

Use conduit type in accordance with the contract. Use Class A concrete for footings and pedestals, Class Drilled Pier concrete for drilled piers and Class AA concrete for grade beams and wings including portions of drilled piers above bottom of wings elevations. Corrugated temporary casings may be accepted at the discretion of the Engineer. A list of approved polymer slurry products is available from:

[connect.ncdot.gov/resources/Geological/Pages/Products.aspx](http://connect.ncdot.gov/resources/Geological/Pages/Products.aspx)

Provide anchor rod assemblies in accordance with the contract consisting of the following:

- (A) Straight anchor rods,
- (B) Heavy hex top and leveling nuts and flat washers on exposed ends of rods, and
- (C) Nuts and either flat plates or washers on the other ends of anchor rods embedded in foundations.

Do not use lock washers. Use steel anchor rods, nuts and washers that meet ASTM F1554 for Grade 55 rods and Grade A nuts. Use steel plates and washers embedded in concrete with a thickness of at least 1/4". Galvanize anchor rods and exposed nuts and washers in accordance with Article 1076-4 of the *2012 Standard Specifications*. It is not necessary to galvanize nuts, plates and washers embedded in concrete.

### **Construction Methods**

Install the required size and number of conduits in foundations in accordance with the plans and accepted submittals. Construct top of piers, footings, pedestals, grade beams and wings flat, level and within 1" of elevations shown in the plans or approved by the Engineer. Provide an Ordinary Surface finish in accordance with Subarticle 825-6(B) of the *2012 Standard Specifications* for portions of foundations exposed above finished grade. Do not remove anchor bolt templates or pedestal or grade beam forms or erect metal poles or upright trusses onto foundations until concrete attains a compressive strength of at least 3,000 psi.

#### **(A) Drilled Piers**

Before starting drilled pier construction, hold a predrill meeting to discuss the installation, monitoring and inspection of the drilled piers. Schedule this meeting after the Drilled Pier Contractor has mobilized to the site. The Resident or Division Traffic Engineer, Contractor and Drilled Pier Contractor Superintendent will attend this predrill meeting.

Do not excavate holes, install piles or allow equipment wheel loads or vibrations within 20 ft of completed piers until 16 hours after Drilled Pier concrete reaches initial set.

Check for correct drilled pier alignment and location before beginning drilling. Check plumbness of holes frequently during drilling.

Construct drilled piers with the minimum required diameters shown in the plans. Install piers with tip elevations no higher than shown in the plans or approved by the Engineer.

Excavate holes with equipment of the sizes required to construct drilled piers. Depending on the subsurface conditions encountered, drilling through rock and boulders may be required. Do not use blasting for drilled pier excavations.

Contain and dispose of drilling spoils and waste concrete as directed and in accordance with Section 802 of the *2012 Standard Specifications*. Drilling spoils consist of all materials and fluids removed from excavations.

If unstable, caving or sloughing materials are anticipated or encountered, stabilize holes with temporary casings and/or polymer slurry. Do not use telescoping temporary casings. If it becomes necessary to replace a temporary casing during drilling, backfill the excavation, insert a larger casing around the casing to be replaced or stabilize the excavation with polymer slurry before removing the temporary casing.

If temporary casings become stuck or the Contractor proposes leaving casings in place, temporary casings should be installed against undisturbed material. Unless otherwise approved, do not leave temporary casings in place for mast arm poles and cantilever signs. The Engineer will determine if casings may remain in place. If the Contractor proposes leaving temporary casings in place, do not begin drilling until a casing installation method is approved.

Use polymer slurry and additives to stabilize holes in accordance with the slurry manufacturer's recommendations. Provide mixing water and equipment suitable for polymer slurry. Maintain polymer slurry at all times so slurry meets Table 411-3 of the *2012 Standard Specifications* except for sand content.

Define a "sample set" as slurry samples collected from mid-height and within 2 ft of the bottom of holes. Take sample sets from excavations to test polymer slurry immediately after filling holes with slurry, at least every 4 hours thereafter and immediately before placing concrete. Do not place Drilled Pier concrete until both slurry samples from an excavation meet the required polymer slurry properties. If any slurry test results do not meet the requirements, the Engineer may suspend drilling until both samples from a sample set meet the required slurry properties.

Remove soft and loose material from bottom of holes using augers to the satisfaction of the Engineer. Assemble rebar cages and place cages and Drilled Pier concrete in accordance with Subarticle 411-4(E) of the *2012 Standard Specifications* except for the following:

- (1) Inspections for tip resistance and bottom cleanliness are not required,
- (2) Temporary casings may remain in place if approved, and
- (3) Concrete placement may be paused near the top of pier elevations for anchor rod assembly installation and conduit placement or
- (4) If applicable, concrete placement may be stopped at bottom of grade beam or wings elevations for grade beam or wing construction.

If wet placement of concrete is anticipated or encountered, do not place Drilled Pier concrete until a concrete placement procedure is approved. If applicable, temporary casings and fluids may be removed when concrete placement is paused or stopped in accordance with the exceptions above provided holes are stable. Remove contaminated concrete from exposed Drilled Pier concrete after removing casings and fluids. If holes are unstable, do not remove temporary casings until a procedure for placing anchor rod assemblies and conduit or constructing grade beams or wings is approved.

Use collars to extend drilled piers above finished grade. Remove collars after Drilled Pier concrete sets and round top edges of piers.



If drilled piers are questionable, pile integrity testing (PIT) and further investigation may be required in accordance with Article 411-5 of the *2012 Standard Specifications*. A drilled pier will be considered defective in accordance with Subarticle 411-5(D) of the *2012 Standard Specifications* and drilled pier acceptance is based in part on the criteria in Article 411-6 of the *2012 Standard Specifications* except for the top of pier tolerances in Subarticle 411-6(C) of the *2012 Standard Specifications*.

If a drilled pier is under further investigation, do not grout core holes, backfill around the pier or perform any work on the drilled pier until the Engineer accepts the pier. If the drilled pier is accepted, dewater and grout core holes and backfill around the pier with approved material to finished grade. If the Engineer determines a pier is unacceptable, remediation is required in accordance with Article 411-6 of the *2012 Standard Specifications*. No extension of completion date or time will be allowed for remediation of unacceptable drilled piers or post repair testing.

Permanently embed a plate in or mark top of piers with the pier diameter and depth, size and number of vertical reinforcing bars and the minimum compressive strength of the concrete mix at 28 days.

(B) Footings, Pedestals, Grade Beams and Wings

Excavate as necessary for footings, grade beams and wings in accordance with the plans, accepted submittals and Section 410 of the *2012 Standard Specifications*. If unstable, caving or sloughing materials are anticipated or encountered, shore foundation excavations as needed with an approved method. Notify the Engineer when foundation excavation is complete. Do not place concrete or reinforcing steel until excavation dimensions and foundation material are approved.

Construct cast-in-place reinforced concrete footings, pedestals, grade beams and wings with the dimensions shown in the plans and in accordance with Section 825 of the *2012 Standard Specifications*. Use forms to construct portions of pedestals and grade beams protruding above finished grade. Provide a chamfer with a 3/4" horizontal width for pedestal and grade beam edges exposed above finished grade. Backfill and fill in accordance with Article 410-8 of the *2012 Standard Specifications*. Proper compaction around footings and wings is critical for foundations to resist uplift and torsion forces. Place concrete against undisturbed soil and do not use forms for standard foundations for low level light standards.

(C) Anchor Rod Assemblies

Size anchor rods for design and the required projection above top of foundations. Determine required anchor rod projections from nut, washer and base plate thicknesses, the protrusion of 3 to 5 anchor rod threads above top nuts after tightening and the distance of one nut thickness between top of foundations and bottom of leveling nuts.

Protect anchor rod threads from damage during storage and installation of anchor rod assemblies. Before placing anchor rods in foundations, turn nuts onto and off rods past leveling nut locations. Turn nuts with the effort of one workman using an ordinary wrench without a cheater bar. Report any thread damage to the Engineer that requires extra effort to turn nuts.

Arrange anchor rods symmetrically about center of base plate locations as shown in the plans. Set anchor rod elevations based on required projections above top of foundations. Securely brace and hold rods in the correct position, orientation and alignment with a steel template. Do not weld to reinforcing steel, temporary casings or anchor rods.

Install top and leveling (bottom) nuts, washers and the base plate for each anchor rod assembly in accordance with the following procedure:

- (1) Turn leveling nuts onto anchor rods to a distance of one nut thickness between the top of foundation and bottom of leveling nuts. Place washers over anchor rods on top of leveling nuts.
- (2) Determine if nuts are level using a flat rigid template on top of washers. If necessary, lower leveling nuts to level the template in all directions or if applicable, lower nuts to tilt the template so the metal pole or upright truss will lean as shown in the plans. If leveling nuts and washers are not in full contact with the template, replace washers with galvanized beveled washers.
- (3) Verify the distance between the foundation and leveling nuts is no more than one nut thickness.
- (4) Place base plate with metal pole or upright truss over anchor rods on top of washers. High mount luminaires may be attached before erecting metal poles but do not attach cables, mast arms or trusses to metal poles or upright trusses at this time.
- (5) Place washers over anchor rods on top of base plate. Lubricate top nut bearing surfaces and exposed anchor rod threads above washers with beeswax, paraffin or other approved lubricant.
- (6) Turn top nuts onto anchor rods. If nuts are not in full contact with washers or washers are not in full contact with the base plate, replace washers with galvanized beveled washers.
- (7) Tighten top nuts to snug-tight with the full effort of one workman using a 12" wrench. Do not tighten any nut all at once. Turn top nuts in increments. Follow a star pattern cycling through each nut at least twice.
- (8) Repeat (7) for leveling nuts.
- (9) Replace washers above and below the base plate with galvanized beveled washers if the slope of any base plate face exceeds 1:20 (5%), any washer is not in firm contact with the base plate or any nut is not in firm contact with a washer. If any washers are replaced, repeat (7) and (8).
- (10) With top and leveling nuts snug-tight, mark each top nut on a corner at the intersection of 2 flats and a corresponding reference mark on the base plate. Mark top nuts and base plate with ink or paint that is not water-soluble. Use the turn-of-nut method for pretensioning. Do not pretension any nut all at once. Turn top nuts in increments for a total turn that meets the following nut rotation requirements:

<b>NUT ROTATION REQUIREMENTS (Turn-of-Nut Pretensioning Method)</b>	
<b>Anchor Rod Diameter, inch</b>	<b>Requirement</b>
$\leq 1 \frac{1}{2}$	1/3 turn (2 flats)
$> 1 \frac{1}{2}$	1/6 turn (1 flat)

Follow a star pattern cycling through each top nut at least twice.

- (11) Ensure nuts, washers and base plate are in firm contact with each other for each anchor rod. Cables, mast arms and trusses may now be attached to metal poles and upright trusses.
- (12) Between 4 and 14 days after pretensioning top nuts, use a torque wrench calibrated within the last 12 months to check nuts in the presence of the Engineer. Completely erect mast arm poles and cantilever signs and attach any hardware before checking top nuts for these structures. Check that top nuts meet the following torque requirements:

<b>TORQUE REQUIREMENTS</b>	
<b>Anchor Rod Diameter, inch</b>	<b>Requirement, ft-lb</b>
7/8	180
1	270
1 1/8	380
1 1/4	420
$\geq 1 \frac{1}{2}$	600

If necessary, retighten top nuts in the presence of the Engineer with a calibrated torque wrench to within  $\pm 10$  ft-lb of the required torque. Do not overtighten top nuts.

- (13) Do not grout under base plate.

### **Measurement and Payment**

Foundations and anchor rod assemblies for metal poles and upright trusses will be measured and paid for elsewhere in the contract.

No payment will be made for temporary casings that remain in drilled pier excavations. No payment will be made for PIT. No payment will be made for further investigation of defective piers. Further investigation of piers that are not defective will be paid as extra work in accordance with Article 104-7 of the *2012 Standard Specifications*. No payment will be made for remediation of unacceptable drilled piers or post repair testing.

### **MATERIALS:**

(2-21-12) (Rev. 11-22-16)

1000, 1002, 1005, 1016, 1018, 1024, 1050, 1074, 1078, 1080, 1081, 1086, 1084, 1087, 1092

SP10 R01

Revise the *2012 Standard Specifications* as follows:

**Page 10-1, Article 1000-1, DESCRIPTION, lines 9-10**, replace the last sentence of the first paragraph with the following:

Type IL, IP, IS or IT blended cement may be used instead of Portland cement.

**Page 10-1, Article 1000-1, DESCRIPTION, line 14**, add the following:

If any change is made to the mix design, submit a new mix design (with the exception of an approved pozzolan source change).

If any major change is made to the mix design, also submit new test results showing the mix design conforms to the criteria. Define a major change to the mix design as:

- (1) A source change in coarse aggregate, fine aggregate or cement.
- (2) A pozzolan class or type change (e.g. Class F fly ash to Class C fly ash).
- (3) A quantitative change in coarse aggregate (applies to an increase or decrease greater than 5%), fine aggregate (applies to an increase or decrease greater than 5%), water (applies to an increase only), cement (applies to a decrease only), or pozzolan (applies to an increase or decrease greater than 5%).

Use materials which do not produce a mottled appearance through rusting or other staining of the finished concrete surface.

**Page 10-1, Article 1000-2, MATERIALS, line 16; Page 10-8, Subarticle 1000-7(A), Materials, line 8; and Page 10-18, Article 1002-2, MATERIALS, line 9,** add the following to the table of item references:

<b>Item</b>	<b>Section</b>
Type II Blended Cement	1024-1

**Page 10-1, Subarticle 1000-3(A), Composition and Design, lines 25-27,** replace the second paragraph with the following:

Fly ash may be substituted for cement in the mix design up to 30% at a rate of 1.0 lb of fly ash to each pound of cement replaced.

**Page 10-2, Subarticle 1000-3(A), Composition and Design, lines 12-21,** delete the third paragraph through the sixth paragraph beginning with “If any change is made to the mix design, submit...” through “...(applies to a decrease only).”

**Page 10-5, Table 1000-1, REQUIREMENTS FOR CONCRETE,** replace with the following:

TABLE 1000-1 REQUIREMENTS FOR CONCRETE											
Class of Concrete	Min. Comp. Strength at 28 days	Maximum Water-Cement Ratio				Consistency Max. Slump		Cement Content			
		Air-Entrained Concrete		Non Air-Entrained Concrete		Vibrated	Non-Vibrated	Vibrated		Non-Vibrated	
		Rounded Aggregate	Angular Aggregate	Rounded Aggregate	Angular Aggregate			Min.	Max.	Min.	Max.
Units	psi					inch	inch	lb/cy	lb/cy	lb/cy	lb/cy
AA	4,500	0.381	0.426	-	-	3.5	-	639	715	-	-
AA Slip Form	4,500	0.381	0.426	-	-	1.5	-	639	715	-	-
Drilled Pier	4,500	-	-	0.450	0.450	-	5-7 dry 7-9 wet	-	-	640	800
A	3,000	0.488	0.532	0.550	0.594	3.5	4	564	-	602	-
B	2,500	0.488	0.567	0.559	0.630	1.5 machine-placed 2.5 hand-placed	4	508	-	545	-
Sand Light-weight	4,500	-	0.420	-	-	4	-	715	-	-	-
Latex Modified	3,000 7 day	0.400	0.400	-	-	6	-	658	-	-	-
Flowable Fill excavatable	150 max. at 56 days	as needed	as needed	as needed	as needed	-	Flowable	-	-	40	100
Flowable Fill non-excavatable	125	as needed	as needed	as needed	as needed	-	Flowable	-	-	100	as needed
Pavement	4,500 design, field 650 flexural, design only	0.559	0.559	-	-	1.5 slip form 3.0 hand place	-	526	-	-	-
Precast	See Table 1077-1	as needed	as needed	-	-	6	as needed	as needed	as needed	as needed	as needed
Prestress	per contract	See Table 1078-1	See Table 1078-1	-	-	8	-	564	as needed	-	-

**Page 10-6, Subarticle 1000-4(I), Use of Fly Ash, lines 36-2,** replace the first paragraph with the following:

Fly ash may be substituted for cement in the mix design up to 30% at a rate of 1.0 lb of fly ash to each pound of cement replaced. Use Table 1000-1 to determine the maximum allowable water-cementitious material (cement + fly ash) ratio for the classes of concrete listed.

**Page 10-7, Table 1000-3, MAXIMUM WATER-CEMENTITIOUS MATERIAL RATIO,** delete the table.

**Page 10-7, Article 1000-5, HIGH EARLY STRENGTH PORTLAND CEMENT CONCRETE, lines 30-31,** delete the second sentence of the third paragraph.

**Page 10-19, Article 1002-3, SHOTCRETE FOR TEMPORARY SUPPORT OF EXCAVATIONS, line 30,** add the following at the end of Section 1002:

**(H) Handling and Storing Test Panels**

Notify the Area Materials Engineer when preconstruction or production test panels are made within 24 hours of shooting the panels. Field cure and protect test panels from damage in accordance with ASTM C1140 until the Department transports panels to the Materials and Tests Regional Laboratory for coring.

**Page 10-23, Table 1005-1, AGGREGATE GRADATION-COARSE AGGREGATE,** replace with the following:

**TABLE 1005-1  
AGGREGATE GRADATION - COARSE AGGREGATE**

Std. Size #	Percentage of Total by Weight Passing														Remarks
	2"	1 1/2"	1"	3/4"	1/2"	3/8"	#4	#8	#10	#16	#40	#200			
4	100	90-100	20-55	0-15	-	0-5	-	-	-	-	-	A	Asphalt Plant Mix		
467M	100	95-100	-	35-70	-	0-30	0-5	-	-	-	-	A	Asphalt Plant Mix		
5	-	100	90-100	20-55	0-10	0-5	-	-	-	-	-	A	AST, Sediment Control Stone		
57	-	100	95-100	-	25-60	-	0-10	0-5	-	-	-	A	AST, Structural Concrete, Shoulder Drain Stone, Sediment Control Stone		
57M	-	100	95-100	-	25-45	-	0-10	0-5	-	-	-	A	AST, Concrete Pavement		
6M	-	-	100	90-100	20-55	0-20	0-8	-	-	-	-	A	AST		
67	-	-	100	90-100	-	20-55	0-10	0-5	-	-	-	A	Asphalt Plant Mix, AST, Structural Concrete		
78M	-	-	-	100	98-100	75-100	20-45	0-15	-	-	-	A	Asphalt Plant Mix, AST, Structural Concrete, Weep Hole Drains		
14M	-	-	-	-	100	98-100	35-70	5-20	-	0-8	-	A	Asphalt Plant Mix, AST, Structural Concrete, Weep Hole Drains		
9M	-	-	-	-	100	98-100	85-100	10-40	-	0-10	-	A	AST		
ABC	-	100	75-97	-	55-80	-	35-55	-	25-45	-	14-30	4-12 <sup>B</sup>	Aggregate Base Course, Aggregate Stabilization		
ABC(M)	-	100	75-100	-	45-79	-	20-40	-	0-25	-	-	0-12 <sup>B</sup>	Maintenance Stabilization		
Light-weight <sup>C</sup>	-	-	-	-	100	80-100	5-40	0-20	-	0-10	-	0-2.5	AST		

- A. See Subarticle 1005-4(A).
- B. See Subarticle 1005-4(B).
- C. For Lightweight Aggregate used in Structural Concrete, see Subarticle 1014-2(E)(6).

Select material is clean, unweathered durable, blasted rock material obtained from an approved source. While no specific gradation is required, the below criteria will be used to evaluate the materials for visual acceptance by the Engineer:

- (A) At least 50% of the rock has a diameter of from 1.5 ft to 3 ft,
- (B) 30% of the rock ranges in size from 2" to 1.5 ft in diameter, and
- (C) Not more than 20% of the rock is less than 2" in diameter. No rippable rock will be permitted.

**Page 10-40, Tables 1018-1 and 1018-2, PIEDMONT, WESTERN AND COASTAL AREA CRITERIA FOR ACCEPTANCE OF BORROW MATERIAL**, under second column in both tables, replace second row with the following:

Acceptable, but not to be used in the top 3 ft of embankment or backfill

**Page 10-46, Article 1024-1, PORTLAND CEMENT, line 33**, add the following as the ninth paragraph:

Use Type IL blended cement that meets AASHTO M 240, except that the limestone content is limited to between 5 and 12% by weight and the constituents shall be interground. Class F fly ash can replace a portion of Type IL blended cement and shall be replaced as outlined in Subarticle 1000-4(I) for Portland cement. For mixes that contain cement with alkali content between 0.6% and 1.0% and for mixes that contain a reactive aggregate documented by the Department, use a pozzolan in the amount shown in Table 1024-1.

**Page 10-46, Table 1024-1, POZZOLANS FOR USE IN PORTLAND CEMENT CONCRETE**, replace with the following:

<b>TABLE 1024-1 POZZOLANS FOR USE IN PORTLAND CEMENT CONCRETE</b>	
<b>Pozzolan</b>	<b>Rate</b>
Class F Fly Ash	20% - 30% by weight of required cement content with 1.0 lb Class F fly ash per lb of cement replaced
Ground Granulated Blast Furnace Slag	35%-50% by weight of required cement content with 1.0 lb slag per lb of cement replaced
Microsilica	4%-8% by weight of required cement content with 1.0 lb microsilica per lb of cement replaced

**Page 10-47, Subarticle 1024-3(B), Approved Sources, lines 16-18**, replace the second sentence of the second paragraph with the following:

Tests shall be performed by AASHTO's designated National Transportation Product Evaluation Program (NTPEP) laboratory for concrete admixture testing.

**Page 10-65, Article 1050-1, GENERAL, line 41**, replace the first sentence with the following:



All fencing material and accessories shall meet Section 106.

**Page 10-115, Subarticle 1074-7(B), Gray Iron Castings, lines 10-11**, replace the first two sentences with the following:

Supply gray iron castings meeting all facets of AASHTO M 306 excluding proof load. Proof load testing will only be required for new casting designs during the design process, and conformance to M306 loading (40,000 lb.) will be required only when noted on the design documents.

**Page 10-126, Table 1078-1, REQUIREMENTS FOR CONCRETE**, replace with the following:

Property	28 Day Design Compressive Strength 6,000 psi or less	28 Day Design Compressive Strength greater than 6,000 psi
Maximum Water/Cementitious Material Ratio	0.45	0.40
Maximum Slump without HRWR	3.5"	3.5"
Maximum Slump with HRWR	8"	8"
Air Content (upon discharge into forms)	5 + 2%	5 + 2%

**Page 10-151, Article 1080-4, INSPECTION AND SAMPLING, lines 18-22**, replace (B), (C) and (D) with the following:

- (B) At least 3 panels prepared as specified in 5.5.10 of AASHTO M 300, Bullet Hole Immersion Test.
- (C) At least 3 panels of 4"x6"x1/4" for the Elcometer Adhesion Pull Off Test, ASTM D4541.
- (D) A certified test report from an approved independent testing laboratory for the Salt Fog Resistance Test, Cyclic Weathering Resistance Test, and Bullet Hole Immersion Test as specified in AASHTO M 300.
- (E) A certified test report from an approved independent testing laboratory that the product has been tested for slip coefficient and meets AASHTO M253, Class B.

**Page 10-161, Subarticle 1081-1(A), Classifications, lines 29-33**, delete first 3 sentences of the description for Type 2 and replace with the following:

**Type 2** - A low-modulus, general-purpose adhesive used in epoxy mortar repairs. It may be used to patch spalled, cracked or broken concrete where vibration, shock or expansion and contraction are expected.

**Page 10-162, Subarticle 1081-1(A), Classifications, lines 4-7**, delete the second and third sentences of the description for Type 3A. **Lines 16-22**, delete Types 6A, 6B and 6C.

**Page 10-162, Subarticle 1081-1(B), Requirements, lines 26-30**, replace the second paragraph with the following:

For epoxy resin systems used for embedding dowel bars, threaded rods, rebar, anchor bolts and other fixtures in hardened concrete, the manufacturer shall submit test results showing that the bonding system will obtain 125% of the specified required yield strength of the fixture. Furnish certification that, for the particular bolt grade, diameter and embedment depth required, the anchor system will not fail by adhesive failure and that there is no movement of the anchor bolt. For certification and anchorage, use 3,000 psi as the minimum Portland cement concrete compressive strength used in this test. Use adhesives that meet Section 1081.

List the properties of the adhesive on the container and include density, minimum and maximum temperature application, setting time, shelf life, pot life, shear strength and compressive strength.

**Page 10-163, Table 1081-1, PROPERTIES OF MIXED EPOXY RESIN SYSTEMS**, replace with the following:

Property	Type 1	Type 2	Type 3	Type 3A	Type 4A	Type 4B	Type 5
Viscosity-Poises at 77°F ± 2°F	Gel	10-30	25-75	Gel	40-150	40-150	1-6
Spindle No.	-	3	4	--	4	4	2
Speed (RPM)	-	20	20	--	10	10	50
Pot Life (Minutes)	20-50	30-60	20-50	5-50	40-80	40-80	20-60
Minimum Tensile Strength at 7 days (psi)	1,500	2,000	4,000	4,000	1,500	1,500	4,000
Tensile Elongation at 7 days (%)	30 min.	30 min.	2-5	2-5	5-15	5-15	2-5
Min. Compressive Strength of 2" mortar cubes at 24 hours	3,000 (Neat)	4,000-	6,000-	6,000 (Neat)	3,000	3,000	6,000
Min. Compressive Strength of 2" mortar cubes at 7 days	5,000 (Neat)	-	-	-	-	5,000	-
Maximum Water Absorption (%)	1.5	1.0	1.0	1.5	1.0	1.0	1.0
Min. Bond Strength Slant Shear Test at 14 days (psi)	1,500	1,500	2,000	2,000	1,500	1,500	1,500

**Page 10-164, Subarticle 1081-1(E), Prequalification, lines 31-33,** replace the second sentence of the first paragraph with the following:

Manufacturers choosing to supply material for Department jobs must submit an application through the Value Management Unit with the following information for each type and brand name:

**Page 10-164, Subarticle 1081-1(E)(3), line 37,** replace with the following:

(3) Type of the material in accordance with Articles 1081-1 and 1081-4,

**Page 10-165, Subarticle 1081-1(E)(6), line 1,** in the first sentence of the first paragraph replace "AASHTO M 237" with "the specifications".

**Page 10-165, Subarticle 1081-1(E), Prequalification, line 9-10,** delete the second sentence of the last paragraph.

**Page 10-165, Subarticle 1081-1(F), Acceptance, line 14,** in the first sentence of the first paragraph replace “Type 1” with “Type 3”.

**Page 10-169, Subarticle 1081-3(G), Anchor Bolt Adhesives,** delete this subarticle.

**Page 10-170, Article 1081-3, HOT BITUMEN, line 9,** add the following at the end of Section 1081:

#### **1081-4 EPOXY RESIN ADHESIVE FOR BONDING TRAFFIC MARKINGS**

##### **(A) General**

This section covers epoxy resin adhesive for bonding traffic markers to pavement surfaces.

##### **(B) Classification**

The types of epoxies and their uses are as shown below:

**Type I** – Rapid Setting, High Viscosity, Epoxy Adhesive. This type of adhesive provides rapid adherence to traffic markers to the surface of pavement.

**Type II** – Standard Setting, High Viscosity, Epoxy Adhesive. This type of adhesive is recommended for adherence of traffic markers to pavement surfaces when rapid set is not required.

**Type III** – Rapid Setting, Low Viscosity, Water Resistant, Epoxy Adhesive. This type of rapid setting adhesive, due to its low viscosity, is appropriate only for use with embedded traffic markers.

**Type IV** – Standard Set Epoxy for Blade Deflecting-Type Plowable Markers.

##### **(C) Requirements**

Epoxies shall conform to the requirements set forth in AASHTO M 237.

##### **(D) Prequalification**

Refer to Subarticle 1081-1(E).

##### **(E) Acceptance**

Refer to Subarticle 1081-1(F).

**Page 10-173, Article 1084-2, STEEL SHEET PILES, lines 37-38,** replace first paragraph with the following:

Steel sheet piles detailed for permanent applications shall be hot rolled and meet ASTM A572 or ASTM A690 unless otherwise required by the plans. Steel sheet piles shall be coated as required by the plans. Galvanized sheet piles shall be coated in accordance with Section 1076.

Metallized sheet piles shall be metallized in accordance to the Project Special Provision “Thermal Sprayed Coatings (Metallization)” with an 8 mil, 99.9% aluminum alloy coating and a 0.5 mil seal coating. Any portion of the metallized sheet piling encased in concrete shall receive a barrier coat. The barrier coat shall be an approved waterborne coating with a low-viscosity which readily absorbs into the pores of the aluminum thermal sprayed coating. The waterborne coating shall be applied at a spreading rate that results in a theoretical 1.5 mil dry film thickness. The manufacturer shall issue a letter of certification that the resin chemistry of the waterborne coating is compatible with the 99.9% aluminum thermal sprayed alloy and suitable for tidal water applications.

**Page 10-174, Subarticle 1086-1(B)(1), Epoxy, lines 18-24,** replace with the following:

The epoxy shall meet Article 1081-4.

The 2 types of epoxy adhesive which may be used are Type I, Rapid Setting, and Type II, Standard Setting. Use Type II when the pavement temperature is above 60°F or per the manufacturer’s recommendations whichever is more stringent. Use Type I when the pavement temperature is between 50°F and 60°F or per the manufacturer’s recommendations whichever is more stringent. Epoxy adhesive Type I, Cold Set, may be used to attach temporary pavement markers to the pavement surface when the pavement temperature is between 32°F and 50°F or per the manufacturer’s recommendations whichever is more stringent.

**Page 10-175, Subarticle 1086-2(E), Epoxy Adhesives, line 27,** replace “Section 1081” with “Article 1081-4”.

**Page 10-177, Subarticle 1086-3(E), Epoxy Adhesives, line 22,** replace “Section 1081” with “Article 1081-4”.

**Page 10-179, Subarticle 1087-4(A), Composition, lines 39-41,** replace the third paragraph with the following:

All intermixed and drop-on glass beads shall not contain more than 75 ppm arsenic or 200 ppm lead.

**Page 10-180, Subarticle 1087-4(B), Physical Characteristics, line 8,** replace the second paragraph with the following:

All intermixed and drop-on glass beads shall comply with NCGS § 136-30.2 and 23 USC § 109(r).

**Page 10-181, Subarticle 1087-7(A), Intermixed and Drop-on Glass Beads, line 24,** add the following after the first paragraph:

Use X-ray Fluorescence for the normal sampling procedure for intermixed and drop-on beads, without crushing, to check for any levels of arsenic and lead. If any arsenic or lead is detected, the sample shall be crushed and repeat the test using X-ray Fluorescence. If the X-ray Fluorescence test shows more than a LOD of 5 ppm, test the beads using United States Environmental Protection Agency Method 6010B, 6010C or 3052 for no more than 75 ppm arsenic or 200 ppm lead.

**HIGH STRENGTH CONCRETE FOR DRIVEWAYS:**

(11-21-00) (Rev. 1-17-12)

848

SP10 R02

Use high early strength concrete for all driveways shown in the plans and as directed by the Engineer. Provide high early strength concrete that meets the requirements of Article 1000-5 of the *2012 Standard Specifications*.

Measurement and payment will be in accordance with Section 848 of the *2012 Standard Specifications*.

**SELECT MATERIAL, CLASS III, TYPE 3:**

(1-17-12)

1016, 1044

SP10 R05

Revise the *2012 Standard Specifications* as follows:

**Page 10-39, Article 1016-3, CLASS III**, add the following after line 14:

**Type 3 Select Material**

Type 3 select material is a natural or manufactured fine aggregate material meeting the following gradation requirements and as described in Sections 1005 and 1006:

Percentage of Total by Weight Passing							
3/8"	#4	#8	#16	#30	#50	#100	#200
100	95-100	65-100	35-95	15-75	5-35	0-25	0-8

**Page 10-39, Article 1016-3, CLASS III, line 15**, replace “either type” with “Type 1, Type 2 or Type 3”.

**Page 10-62, Article 1044-1, line 36**, delete the sentence and replace with the following:

Subdrain fine aggregate shall meet Class III select material, Type 1 or Type 3.

**Page 10-63, Article 1044-2, line 2**, delete the sentence and replace with the following:

Subdrain coarse aggregate shall meet Class V select material.

**SHOULDER AND SLOPE BORROW:**

(3-19-13)

1019

SP10 R10

Use soil in accordance with Section 1019 of the *2012 Standard Specifications*. Use soil consisting of loose, friable, sandy material with a PI greater than 6 and less than 25 and a pH ranging from 5.5 to 7.0.

Soil with a pH ranging from 4.0 to 5.5 will be accepted without further testing if additional limestone is provided in accordance with the application rates shown in Table 1019-1A. Soil type is identified during the soil analysis. Soils with a pH above 7.0 require acidic amendments to be added. Submit proposed acidic amendments to the Engineer for review and approval. Soils with a pH below 4.0 or that do not meet the PI requirements shall not be used.

<b>pH TEST RESULT</b>	<b>Sandy Soils Additional Rate (lbs. / Acre)</b>	<b>Silt Loam Soils Additional Rate (lbs. / Acre)</b>	<b>Clay Loam Soils Additional Rate (lbs. / Acre)</b>
4.0 - 4.4	1,000	4,000	6,000
4.5 - 4.9	500	3,000	5,000
5.0 - 5.4	NA	2,000	4,000

Note: Limestone application rates shown in this table are in addition to the standard rate of 4000 lbs. / acre required for seeding and mulching.

No direct payment will be made for providing additional lime or acidic amendments for Ph adjustment.

### **GROUT PRODUCTION AND DELIVERY:**

(3-17-15)

1003

SP10 R20

Revise the *2012 Standard Specifications* as follows:

Replace Section 1003 with the following:

### **SECTION 1003 GROUT PRODUCTION AND DELIVERY**

#### **1003-1 DESCRIPTION**

This section addresses cement grout to be used for structures, foundations, retaining walls, concrete barriers, embankments, pavements and other applications in accordance with the contract. Produce non-metallic grout composed of Portland cement and water and at the Contractor's option or as required, aggregate and pozzolans. Include chemical admixtures as required or needed. Provide sand cement or neat cement grout as required. Define "sand cement grout" as grout with only fine aggregate and "neat cement grout" as grout without aggregate.

The types of grout with their typical uses are as shown below:

**Type 1** – A cement grout with only a 3-day strength requirement and a fluid consistency that is typically used for filling subsurface voids.

**Type 2** – A nonshrink grout with strength, height change and flow conforming to ASTM C1107 that is typically used for foundations, ground anchors and soil nails.

**Type 3** – A nonshrink grout with high early strength and freeze-thaw durability requirements that is typically used in pile blockouts, grout pockets, shear keys, dowel holes and recesses for concrete barriers and structures.

**Type 4** – A neat cement grout with low strength, a fluid consistency and high fly ash content that is typically used for slab jacking.

**Type 5** – A low slump, low mobility sand cement grout with minimal strength that is typically used for compaction grouting.

### 1003-2 MATERIALS

Refer to Division 10.

<b>Item</b>	<b>Section</b>
Chemical Admixtures	1024-3
Fine Aggregate	1014-1
Fly Ash	1024-5
Ground Granulated Blast Furnace Slag	1024-6
Portland Cement	1024-1
Silica Fume	1024-7
Water	1024-4

Do not use grout that contains soluble chlorides or more than 1% soluble sulfate. At the Contractor's option, use an approved packaged grout instead of the materials above except for water. Use packaged grouts that are on the NCDOT Approved Products List.

Use admixtures for grout that are on the NCDOT Approved Products List or other admixtures in accordance with Subarticle 1024-3(E) except do not use concrete additives or unclassified or other admixtures in Type 4 or 5 grout. Use Class F fly ash for Type 4 grout and Type II Portland cement for Type 5 grout.

Use well graded rounded aggregate with a gradation, liquid limit (LL) and plasticity index (PI) that meet Table 1003-1 for Type 5 grout. Fly ash may be substituted for a portion of the fines in the aggregate. Do not use any other pozzolans in Type 5 grout.

<b>Gradation</b>		<b>Maximum Liquid Limit</b>	<b>Maximum Plasticity Index</b>
<b>Sieve Designation per AASHTO M 92</b>	<b>Percentage Passing (% by weight)</b>		
3/8"	100	N/A	N/A
No. 4	70 – 95		
No. 8	50 – 90		
No. 16	30 – 80		
No. 30	25 – 70		
No. 50	20 – 50		
No. 100	15 – 40		
No. 200	10 – 30	25	10



**1003-3 COMPOSITION AND DESIGN**

When using an approved packaged grout, a grout mix design submittal is not required. Otherwise, submit proposed grout mix designs for each grout mix to be used in the work. Mixes for all grout shall be designed by a Certified Concrete Mix Design Technician or an Engineer licensed by the State of North Carolina. Mix proportions shall be determined by a testing laboratory approved by the Department. Base grout mix designs on laboratory trial batches that meet Table 1003-2 and this section. With permission, the Contractor may use a quantity of chemical admixture within the range shown on the current list of approved admixtures maintained by the Materials and Tests Unit.

Submit grout mix designs in terms of saturated surface dry weights on Materials and Tests Form 312U at least 35 days before proposed use. Adjust batch proportions to compensate for surface moisture contained in the aggregates at the time of batching. Changes in the saturated surface dry mix proportions will not be permitted unless revised grout mix designs have been submitted to the Engineer and approved.

Accompany Materials and Tests Form 312U with a listing of laboratory test results of compressive strength, density and flow or slump and if applicable, aggregate gradation, durability and height change. List the compressive strength of at least three 2" cubes at the age of 3 and 28 days.

The Engineer will review the grout mix design for compliance with the contract and notify the Contractor as to its acceptability. Do not use a grout mix until written notice has been received. Acceptance of the grout mix design or use of approved packaged grouts does not relieve the Contractor of his responsibility to furnish a product that meets the contract. Upon written request from the Contractor, a grout mix design accepted and used satisfactorily on any Department project may be accepted for use on other projects.

Perform laboratory tests in accordance with the following test procedures:

<b>Property</b>	<b>Test Method</b>
Aggregate Gradation <sup>A</sup>	AASHTO T 27
Compressive Strength	AASHTO T 106
Density (Unit Weight)	AASHTO T 121, AASHTO T 133 <sup>B</sup> , ANSI/API RPC <sup>C</sup> 13B-1 <sup>B</sup> (Section 4, Mud Balance)
Durability	AASHTO T 161 <sup>D</sup>
Flow	ASTM C939 (Flow Cone)
Height Change	ASTM C1090 <sup>E</sup>
Slump	AASHTO T 119

- A.** Applicable to grout with aggregate.
- B.** Applicable to Neat Cement Grout.
- C.** American National Standards Institute/American Petroleum Institute Recommended Practice.
- D.** Procedure A (Rapid Freezing and Thawing in Water) required.
- E.** Moist room storage required.

### 1003-4 GROUT REQUIREMENTS

Provide grout types in accordance with the contract. Use grouts with properties that meet Table 1003-2. The compressive strength of the grout will be considered the average compressive strength test results of three 2" cubes at each age. Make cubes that meet AASHTO T 106 from the grout delivered for the work or mixed on-site. Make cubes at such frequencies as the Engineer may determine and cure them in accordance with AASHTO T 106.

Type of Grout	Minimum Compressive Strength at		Height Change at 28 days	Flow <sup>A</sup> /Slump <sup>B</sup>	Minimum Durability Factor
	3 days	28 days			
1	3,000 psi	–	–	10 – 30 sec	–
2	Table 1 <sup>C</sup>			Fluid Consistency <sup>C</sup>	–
3	5,000 psi	–	0 – 0.2%	Per Accepted Grout Mix Design/ Approved Packaged Grout	80
4 <sup>D</sup>	600 psi	1,500 psi	–	10 – 26 sec	–
5	–	500 psi	–	1 – 3"	–

A. Applicable to Type 1 through 4 grouts.

B. Applicable to Type 5 grout.

C. ASTM C1107.

D. Use Type 4 grout with proportions by volume of 1 part cement and 3 parts fly ash.

### 1003-5 TEMPERATURE REQUIREMENTS

When using an approved packaged grout, follow the manufacturer's instructions for grout and air temperature at the time of placement. Otherwise, the grout temperature at the time of placement shall be not less than 50°F nor more than 90°F. Do not place grout when the air temperature measured at the location of the grouting operation in the shade away from artificial heat is below 40°F.

### 1003-6 ELAPSED TIME FOR PLACING GROUT

Agitate grout continuously before placement. Regulate the delivery so the maximum interval between the placing of batches at the work site does not exceed 20 minutes. Place grout before exceeding the times in Table 1003-3. Measure the elapsed time as the time between adding the mixing water to the grout mix and placing the grout.

<b>TABLE 1003-3 ELAPSED TIME FOR PLACING GROUT (with continuous agitation)</b>		
<b>Air or Grout Temperature, Whichever is Higher</b>	<b>Maximum Elapsed Time</b>	
	<b>No Retarding Admixture Used</b>	<b>Retarding Admixture Used</b>
90°F or above	30 minutes	1 hr. 15 minutes
80°F through 89°F	45 minutes	1 hr. 30 minutes
79°F or below	60 minutes	1 hr. 45 minutes

**1003-7 MIXING AND DELIVERY**

Use grout free of any lumps and undispersed cement. When using an approved packaged grout, mix grout in accordance with the manufacturer's instructions. Otherwise, comply with Articles 1000-8 through 1000-12 to the extent applicable for grout instead of concrete.

**GEOSYNTHETICS:**

(2-16-16)

1056

SP10 R25

Revise the *2012 Standard Specifications* as follows:

Replace Section 1056 with the following:

**SECTION 1056  
GEOSYNTHETICS**

**1056-1 DESCRIPTION**

Provide geosynthetics for subsurface drainage, separation, stabilization, reinforcement, erosion control, filtration and other applications in accordance with the contract. Use geotextiles, geocomposite drains and geocells that are on the NCDOT Approved Products List. Prefabricated geocomposite drains include sheet, strip and vertical drains (PVDs), i.e., "wick drains" consisting of a geotextile attached to and/or encapsulating a plastic drainage core. Geocells are comprised of ultrasonically welded polymer strips that when expanded form a 3D honeycomb grid that is typically filled with material to support vegetation.

If necessary or required, hold geotextiles and sheet drains in place with new wire staples, i.e., "sod staples" that meet Subarticle 1060-8(D) or new anchor pins. Use steel anchor pins with a diameter of at least 3/16" and a length of at least 18" and with a point at one end and a head at the other end that will retain a steel washer with an outside diameter of at least 1.5".

**1056-2 HANDLING AND STORING**

Load, transport, unload and store geosynthetics so geosynthetics are kept clean and free of damage. Label, ship and store geosynthetics in accordance with Section 7 of AASHTO M 288. Geosynthetics with defects, flaws, deterioration or damage will be rejected. Do not unwrap geosynthetics until just before installation. Do not leave geosynthetics exposed for more than 7 days before covering except for geosynthetics for temporary wall faces and erosion control.

**1056-3 CERTIFICATIONS**

Provide Type 1, Type 2 or Type 4 material certifications in accordance with Article 106-3 for geosynthetics. Define “minimum average roll value” (MARV) in accordance with ASTM D4439. Provide certifications with MARV for geosynthetic properties as required. Test geosynthetics using laboratories accredited by the Geosynthetic Accreditation Institute (GAI) to perform the required test methods. Sample geosynthetics in accordance with ASTM D4354.

**1056-4 GEOTEXTILES**

When required, sew geotextiles together in accordance with Article X1.1.4 of AASHTO M 288. Provide sewn seams with seam strengths meeting the required strengths for the geotextile type and class specified.

Provide geotextile types and classes in accordance with the contract. Geotextiles will be identified by the product name printed directly on the geotextile. When geotextiles are not marked with a product name or marked with only a manufacturing plant identification code, geotextiles will be identified by product labels attached to the geotextile wrapping. When identification is based on labels instead of markings, unwrap geotextiles just before use in the presence of the Engineer to confirm that the product labels on both ends of the outside of the geotextile outer wrapping match the labels affixed to both ends of the inside of the geotextile roll core. Partial geotextile rolls without the product name printed on the geotextile or product labels affixed to the geotextile roll core may not be used.

Use woven or nonwoven geotextiles with properties that meet Table 1056-1. Define “machine direction” (MD) and “cross-machine direction” (CD) in accordance with ASTM D4439.

<b>TABLE 1056-1 GEOTEXTILE REQUIREMENTS</b>						
<b>Property</b>	<b>Requirement</b>					<b>Test Method</b>
	<b>Type 1</b>	<b>Type 2</b>	<b>Type 3<sup>A</sup></b>	<b>Type 4</b>	<b>Type 5<sup>B</sup></b>	
<i>Typical Application</i>	<i>Shoulder Drains</i>	<i>Under Rip Rap</i>	<i>Silt Fence Fabric</i>	<i>Soil Stabilization</i>	<i>Temporary Walls</i>	
Elongation (MD & CD)	≥ 50%	≥ 50%	≤ 25%	< 50%	< 50%	ASTM D4632
Grab Strength (MD & CD)	Table 1 <sup>D</sup> , Class 3	Table 1 <sup>D</sup> , Class 1	100 lb <sup>C</sup>	Table 1 <sup>D</sup> , Class 3	–	ASTM D4632
Tear Strength (MD & CD)			–			ASTM D4533
Puncture Strength			–			ASTM D6241
Ultimate Tensile Strength (MD & CD)	–	–	–	–	2,400 lb/ft <sup>C</sup> (unless required otherwise in the contract)	ASTM D4595
Permittivity	Table 2 <sup>D</sup> , 15% to 50% <i>in Situ</i> Soil Passing 0.075 mm	Table 6 <sup>D</sup> , 15% to 50% <i>in Situ</i> Soil Passing 0.075mm	Table 7 <sup>D</sup>	Table 5 <sup>D</sup>	0.20 sec <sup>-1.C</sup>	ASTM D4491
Apparent Opening Size					0.60 mm <sup>E</sup>	ASTM D4751
UV Stability (Retained Strength)					70% <sup>C</sup> (after 500 hr of exposure)	ASTM D4355

- A. Minimum roll width of 36" required.  
 B. Minimum roll width of 13 ft required.  
 C. MARV per Article 1056-3.  
 D. AASHTO M 288.  
 E. Maximum average roll value.

**1056-5 GEOCOMPOSITE DRAINS**

Provide geocomposite drain types in accordance with the contract and with properties that meet Table 1056-2.

<b>TABLE 1056-2 GEOCOMPOSITE DRAIN REQUIREMENTS</b>				
<b>Property</b>	<b>Requirement</b>			<b>Test Method</b>
	<b>Sheet Drain</b>	<b>Strip Drain</b>	<b>Wick Drain</b>	
Width	≥ 12" (unless required otherwise in the contract)	12" ±1/4"	4" ±1/4"	N/A
In-Plane Flow Rate <sup>A</sup> (with gradient of 1.0 and 24-hour seating period)	6 gpm/ft @ applied normal compressive stress of 10 psi	15 gpm/ft @ applied normal compressive stress of 7.26 psi	1.5 gpm <sup>B</sup> @ applied normal compressive stress of 40 psi	ASTM D4716

A. MARV per Article 1056-3.

B. Per 4" drain width.

For sheet and strip drains, use accessories (e.g., pipe outlets, connectors, fittings, etc.) recommended by the Drain Manufacturer. Provide sheet and strip drains with Type 1 geotextiles heat bonded or glued to HDPE, polypropylene or high impact polystyrene drainage cores that meet Table 1056-3.

<b>TABLE 1056-3 DRAINAGE CORE REQUIREMENTS</b>			
<b>Property</b>	<b>Requirement (MARV)</b>		<b>Test Method</b>
	<b>Sheet Drain</b>	<b>Strip Drain</b>	
Thickness	1/4"	1"	ASTM D1777 or D5199
Compressive Strength	40 psi	30 psi	ASTM D6364

For wick drains with a geotextile wrapped around a corrugated drainage core and seamed to itself, use drainage cores with an ultimate tensile strength of at least 225 lb per 4" width in accordance with ASTM D4595 and geotextiles with properties that meet Table 1056-4.

<b>TABLE 1056-4 WICK DRAIN GEOTEXTILE REQUIREMENTS</b>		
<b>Property</b>	<b>Requirement</b>	<b>Test Method</b>
Elongation	≥ 50%	ASTM D4632
Grab Strength	Table 1 <sup>A</sup> , Class 3	ASTM D4632
Tear Strength		ASTM D4533
Puncture Strength		ASTM D6241
Permittivity	0.7 sec <sup>-1</sup> . <sup>B</sup>	ASTM D4491
Apparent Opening Size (AOS)	Table 2 <sup>A</sup> ,	ASTM D4751
UV Stability (Retained Strength)	> 50% <i>in Situ</i> Soil Passing 0.075 mm	ASTM D4355

- A. AASHTO M 288.
- B. MARV per Article 1056-3.

For wick drains with a geotextile fused to both faces of a corrugated drainage core along the peaks of the corrugations, use wick drains with an ultimate tensile strength of at least 1,650 lb/ft in accordance with ASTM D4595 and geotextiles with a permittivity, AOS and UV stability that meet Table 1056-4.

### 1056-6 GEOCELLS

Geocells will be identified by product labels attached to the geocell wrapping. Unwrap geocells just before use in the presence of the Engineer. Previously opened geocell products will be rejected.

Manufacture geocells from virgin polyethylene resin with no more than 10% rework, also called "regrind", materials. Use geocells made from textured and perforated HDPE strips with an open area of 10% to 20% and properties that meet Table 1056-5.

<b>TABLE 1056-5 GEOCELL REQUIREMENTS</b>		
<b>Property</b>	<b>Minimum Requirement</b>	<b>Test Method</b>
Cell Depth	4"	N/A
Sheet Thickness	50 mil -5%, +10%	ASTM D5199
Density	58.4 lb/cf	ASTM D1505
Carbon Black Content	1.5%	ASTM D1603 or D4218
ESCR <sup>A</sup>	5000 hr	ASTM D1693
Coefficient of Direct Sliding (with material that meets AASHTO M 145 for soil classification A-2)	0.85	ASTM D5321
Short-Term Seam (Peel) Strength (for 4" seam)	320 lb	USACE <sup>C</sup> Technical Report GL-86-19, Appendix A
Long-Term Seam (Hang) Strength <sup>B</sup> (for 4" seam)	160 lb	

- A. Environmental Stress Crack Resistance.
- B. Minimum test period of 168 hr with a temperature change from 74°F to 130°F in 1-hour cycles.
- C. US Army Corps of Engineers.

Provide geocell accessories (e.g., stakes, pins, clips, staples, rings, tendons, anchors, deadmen, etc.) recommended by the Geocell Manufacturer.

### **TRUCK MOUNTED CHANGEABLE MESSAGE SIGNS:**

(8-21-12)

1101.02

SP11 R10

Revise the 2012 Roadway Standard Drawings as follows:

**Drawing No. 1101.02, Sheet 12, TEMPORARY LANE CLOSURES**, replace General Note #11 with the following:

11- TRUCK MOUNTED CHANGEABLE MESSAGE SIGNS (TMCMS) USED ON SHADOW VEHICLES FOR "IN LANE" ACTIVITIES SHALL BE A MINIMUM OF 43" X 73". THE DISPLAY PANEL SHALL HAVE FULL MATRIX CAPABILITY WITH THE CAPABILITY TO PROVIDE 2 MESSAGE LINES WITH 7 CHARACTERS PER LINE WITH A MINIMUM CHARACTER HEIGHT OF 18". FOR ADDITIONAL MESSAGING, CONTACT THE WORK ZONE TRAFFIC CONTROL SECTION.

12- TMCMS USED FOR ADVANCED WARNING ON VEHICLES LOCATED ON THE SHOULDER MAY BE SMALLER THAN 43" X 73". THE DISPLAY PANEL SHALL HAVE THE CAPABILITY TO PROVIDE 2 MESSAGE LINES WITH 7 CHARACTERS PER LINE WITH A MINIMUM CHARACTER HEIGHT OF 18". FOR ADDITIONAL MESSAGING, CONTACT THE WORK ZONE TRAFFIC CONTROL SECTION.

**Drawing No. 1101.02, Sheet 13, TEMPORARY LANE CLOSURES**, replace General Note #12 with the following:

12- TRUCK MOUNTED CHANGEABLE MESSAGE SIGNS (TMCMS) USED ON SHADOW VEHICLES FOR "IN LANE" ACTIVITIES SHALL BE A MINIMUM OF 43" X 73". THE DISPLAY PANEL SHALL HAVE FULL MATRIX CAPABILITY WITH THE CAPABILITY TO PROVIDE 2 MESSAGE LINES WITH 7 CHARACTERS PER LINE WITH A MINIMUM CHARACTER HEIGHT OF 18". FOR ADDITIONAL MESSAGING, CONTACT THE WORK ZONE TRAFFIC CONTROL SECTION.

13- TMCMS USED FOR ADVANCED WARNING ON VEHICLES LOCATED ON THE SHOULDER MAY BE SMALLER THAN 43" X 73". THE DISPLAY PANEL SHALL HAVE THE CAPABILITY TO PROVIDE 2 MESSAGE LINES WITH 7 CHARACTERS PER LINE WITH A MINIMUM CHARACTER HEIGHT OF 18". FOR ADDITIONAL MESSAGING, CONTACT THE WORK ZONE TRAFFIC CONTROL SECTION.

**PERMANENT SEEDING AND MULCHING:**

(7-1-95)

1660

SP16 R02

The Department desires that permanent seeding and mulching be established on this project as soon as practical after slopes or portions of slopes have been graded. As an incentive to obtain an early stand of vegetation on this project, the Contractor's attention is called to the following:

For all permanent seeding and mulching that is satisfactorily completed in accordance with the requirements of Section 1660 in the *2012 Standard Specifications* and within the following percentages of elapsed contract times, an additional payment will be made to the Contractor as an incentive additive. The incentive additive will be determined by multiplying the number of acres of seeding and mulching satisfactorily completed times the contract unit bid price per acre for Seeding and Mulching times the appropriate percentage additive.

Percentage of Elapsed Contract Time	Percentage Additive
0% - 30%	30%
30.01% - 50%	15%

Percentage of elapsed contract time is defined as the number of calendar days from the date of availability of the contract to the date the permanent seeding and mulching is acceptably completed divided by the total original contract time.



**STANDARD SPECIAL PROVISION**  
**AVAILABILITY OF FUNDS – TERMINATION OF CONTRACTS**

(5-20-08)

Z-2

*General Statute 143C-6-11. (h) Highway Appropriation* is hereby incorporated verbatim in this contract as follows:

(h) Amounts Encumbered. – Transportation project appropriations may be encumbered in the amount of allotments made to the Department of Transportation by the Director for the estimated payments for transportation project contract work to be performed in the appropriation fiscal year. The allotments shall be multiyear allotments and shall be based on estimated revenues and shall be subject to the maximum contract authority contained in *General Statute 143C-6-11(c)*. Payment for transportation project work performed pursuant to contract in any fiscal year other than the current fiscal year is subject to appropriations by the General Assembly. Transportation project contracts shall contain a schedule of estimated completion progress, and any acceleration of this progress shall be subject to the approval of the Department of Transportation provided funds are available. The State reserves the right to terminate or suspend any transportation project contract, and any transportation project contract shall be so terminated or suspended if funds will not be available for payment of the work to be performed during that fiscal year pursuant to the contract. In the event of termination of any contract, the contractor shall be given a written notice of termination at least 60 days before completion of scheduled work for which funds are available. In the event of termination, the contractor shall be paid for the work already performed in accordance with the contract specifications.

Payment will be made on any contract terminated pursuant to the special provision in accordance with Subarticle 108-13(E) of the *2012 Standard Specifications*.

**STANDARD SPECIAL PROVISION**  
**NCDOT GENERAL SEED SPECIFICATION FOR SEED QUALITY**

(5-17-11)

Z-3

Seed shall be sampled and tested by the North Carolina Department of Agriculture and Consumer Services, Seed Testing Laboratory. When said samples are collected, the vendor shall supply an independent laboratory report for each lot to be tested. Results from seed so sampled shall be final. Seed not meeting the specifications shall be rejected by the Department of Transportation and shall not be delivered to North Carolina Department of Transportation warehouses. If seed has been delivered it shall be available for pickup and replacement at the supplier's expense.

Any re-labeling required by the North Carolina Department of Agriculture and Consumer Services, Seed Testing Laboratory, that would cause the label to reflect as otherwise specified herein shall be rejected by the North Carolina Department of Transportation.

Seed shall be free from seeds of the noxious weeds Johnsongrass, Balloonvine, Jimsonweed, Witchweed, Itchgrass, Serrated Tussock, Showy Crotalaria, Smooth Crotalaria, Sicklepod, Sandbur, Wild Onion, and Wild Garlic. Seed shall not be labeled with the above weed species on the seed analysis label. Tolerances as applied by the Association of Official Seed Analysts will NOT be allowed for the above noxious weeds except for Wild Onion and Wild Garlic.

Tolerances established by the Association of Official Seed Analysts will generally be recognized. However, for the purpose of figuring pure live seed, the found pure seed and found germination percentages as reported by the North Carolina Department of Agriculture and Consumer Services, Seed Testing Laboratory will be used. Allowances, as established by the NCDOT, will be recognized for minimum pure live seed as listed on the following pages.

The specifications for restricted noxious weed seed refers to the number per pound as follows:

<u>Restricted Noxious Weed</u>	<u>Limitations per Lb. Of Seed</u>	<u>Restricted Noxious Weed</u>	<u>Limitations per Lb. of Seed</u>
Blessed Thistle	4 seeds	Cornflower (Ragged Robin)	27 seeds
Cocklebur	4 seeds	Texas Panicum	27 seeds
Spurred Anoda	4 seeds	Bracted Plantain	54 seeds
Velvetleaf	4 seeds	Buckhorn Plantain	54 seeds
Morning-glory	8 seeds	Broadleaf Dock	54 seeds
Corn Cockle	10 seeds	Curly Dock	54 seeds
Wild Radish	12 seeds	Dodder	54 seeds
Purple Nutsedge	27 seeds	Giant Foxtail	54 seeds
Yellow Nutsedge	27 seeds	Horsenettle	54 seeds
Canada Thistle	27 seeds	Quackgrass	54 seeds
Field Bindweed	27 seeds	Wild Mustard	54 seeds
Hedge Bindweed	27 seeds		

Seed of Pensacola Bahiagrass shall not contain more than 7% inert matter, Kentucky Bluegrass, Centipede and Fine or Hard Fescue shall not contain more than 5% inert matter whereas a maximum of 2% inert matter will be allowed on all other kinds of seed. In addition, all seed shall

not contain more than 2% other crop seed nor more than 1% total weed seed. The germination rate as tested by the North Carolina Department of Agriculture shall not fall below 70%, which includes both dormant and hard seed. Seed shall be labeled with not more than 7%, 5% or 2% inert matter (according to above specifications), 2% other crop seed and 1% total weed seed.

Exceptions may be made for minimum pure live seed allowances when cases of seed variety shortages are verified. Pure live seed percentages will be applied in a verified shortage situation. Those purchase orders of deficient seed lots will be credited with the percentage that the seed is deficient.

**FURTHER SPECIFICATIONS FOR EACH SEED GROUP ARE GIVEN BELOW:**

Minimum 85% pure live seed; maximum 1% total weed seed; maximum 2% total other crop seed; maximum 144 restricted noxious weed seed per pound. Seed less than 83% pure live seed will not be approved.

Sericea Lespedeza  
Oats (seeds)

Minimum 80% pure live seed; maximum 1% total weed seed; maximum 2% total other crop; maximum 144 restricted noxious weed seed per pound. Seed less than 78% pure live seed will not be approved.

Tall Fescue (all approved varieties)	Bermudagrass
Kobe Lespedeza	Browntop Millet
Korean Lespedeza	German Millet – Strain R
Weeping Lovegrass	Clover – Red/White/Crimson
Carpetgrass	

Minimum 78% pure live seed; maximum 1% total weed seed; maximum 2% total other crop seed; maximum 144 restricted noxious weed seed per pound. Seed less than 76% pure live seed will not be approved.

Common or Sweet Sundangrass

Minimum 76% pure live seed; maximum 1% total weed seed; maximum 2% total other crop seed; maximum 144 restricted noxious weed seed per pound. Seed less than 74% pure live seed will not be approved.

Rye (grain; all varieties)  
Kentucky Bluegrass (all approved varieties)  
Hard Fescue (all approved varieties)  
Shrub (bicolor) Lespedeza

Minimum 70% pure live seed; maximum 1% total weed seed; maximum 2% total other crop seed; maximum 144 noxious weed seed per pound. Seed less than 70% pure live seed will not be approved.

Centipedegrass	Japanese Millet
Crownvetch	Reed Canary Grass
Pensacola Bahiagrass	Zoysia
Creeping Red Fescue	

Minimum 70% pure live seed; maximum 1% total weed seed; maximum 2% total other crop seed; maximum 5% inert matter; maximum 144 restricted noxious weed seed per pound.

Barnyard Grass  
Big Bluestem  
Little Bluestem  
Bristly Locust  
Birdsfoot Trefoil  
Indiangrass  
Orchardgrass  
Switchgrass  
Yellow Blossom Sweet Clover

**STANDARD SPECIAL PROVISION****ERRATA**

(1-17-12) (Rev. 04-21-15)

Z-4

Revise the *2012 Standard Specifications* as follows:

**Division 2**

**Page 2-7, line 31, Article 215-2 Construction Methods**, replace “Article 107-26” with “Article 107-25”.

**Page 2-17, Article 226-3, Measurement and Payment, line 2**, delete “pipe culverts,”.

**Page 2-20, Subarticle 230-4(B), Contractor Furnished Sources, change references as follows:**  
**Line 1**, replace “(4) Buffer Zone” with “(c) Buffer Zone”; **Line 12**, replace “(5) Evaluation for Potential Wetlands and Endangered Species” with “(d) Evaluation for Potential Wetlands and Endangered Species”; and **Line 33**, replace “(6) Approval” with “(4) Approval”.

**Division 3**

**Page 3-1, after line 15, Article 300-2 Materials**, replace “1032-9(F)” with “1032-6(F)”.

**Division 4**

**Page 4-77, line 27, Subarticle 452-3(C) Concrete Coping**, replace “sheet pile” with “reinforcement”.

**Division 6**

**Page 6-7, line 31, Article 609-3 Field Verification of Mixture and Job Mix Formula Adjustments**, replace “30” with “45”.

**Page 6-10, line 42, Subarticle 609-6(C)(2)**, replace “Subarticle 609-6(E)” with “Subarticle 609-6(D)”.

**Page 6-11, Table 609-1 Control Limits**, replace “Max. Spec. Limit” for the Target Source of  $P_{0.075}/P_{be}$  Ratio with “1.0”.

**Page 6-40, Article 650-2 Materials**, replace “Subarticle 1012-1(F)” with “Subarticle 1012-1(E)”

**Division 7**

**Page 7-1, Article 700-3, CONCRETE HAULING EQUIPMENT**, line 33, replace “competition” with “completion”.

**Division 8**

**Page 8-23, line 10, Article 838-2 Materials**, replace “Portland Cement Concrete, Class B” with “Portland Cement Concrete, Class A”.

**Division 10**

**Page 10-166, Article 1081-3 Hot Bitumen**, replace “Table 1081-16” with “Table 1081-2”, replace “Table 1081-17” with “Table 1081-3”, and replace “Table 1081-18” with “Table 1081-4”.

**Division 12**

**Page 12-7, Table 1205-3**, add “FOR THERMOPLASTIC” to the end of the title.

**Page 12-8, Subarticle 1205-5(B), line 13**, replace “Table 1205-2” with “Table 1205-4”.

**Page 12-8, Table 1205-4 and 1205-5**, replace “THERMOPLASTIC” in the title of these tables with “POLYUREA”.

**Page 12-9, Subarticle 1205-6(B), line 21**, replace “Table 1205-4” with “Table 1205-6”.

**Page 12-11, Subarticle 1205-8(C), line 25**, replace “Table 1205-5” with “Table 1205-7”.

**Division 15**

**Page 15-4, Subarticle 1505-3(F) Backfilling, line 26**, replace “Subarticle 235-4(C)” with “Subarticle 235-3(C)”.

**Page 15-6, Subarticle 1510-3(B), after line 21**, replace the allowable leakage formula with the following:  $W=LD\sqrt{P} \div 148,000$

**Page 15-6, Subarticle 1510-3(B), line 32**, delete “may be performed concurrently or” and replace with “shall be performed”.

**Page 15-17, Subarticle 1540-3(E), line 27**, delete “Type 1”.

**Division 17**

**Page 17-26, line 42, Subarticle 1731-3(D) Termination and Splicing within Interconnect Center**, delete this subarticle.

Revise the *2012 Roadway Standard Drawings* as follows:

**1633.01 Sheet 1 of 1, English Standard Drawing for Matting Installation**, replace “1633.01” with “1631.01”.

**STANDARD SPECIAL PROVISION****PLANT AND PEST QUARANTINES****(Imported Fire Ant, Gypsy Moth, Witchweed, Emerald Ash Borer, And Other Noxious Weeds)**

(3-18-03) (Rev. 12-20-16)

Z-04a

**Within Quarantined Area**

This project may be within a county regulated for plant and/or pests. If the project or any part of the Contractor's operations is located within a quarantined area, thoroughly clean all equipment prior to moving out of the quarantined area. Comply with federal/state regulations by obtaining a certificate or limited permit for any regulated article moving from the quarantined area.

**Originating in a Quarantined County**

Obtain a certificate or limited permit issued by the N.C. Department of Agriculture/United States Department of Agriculture. Have the certificate or limited permit accompany the article when it arrives at the project site.

**Contact**

Contact the N.C. Department of Agriculture/United States Department of Agriculture at 1-800-206-9333, 919-707-3730, or <http://www.ncagr.gov/plantindustry/> to determine those specific project sites located in the quarantined area or for any regulated article used on this project originating in a quarantined county.

**Regulated Articles Include**

1. Soil, sand, gravel, compost, peat, humus, muck, and decomposed manure, separately or with other articles. This includes movement of articles listed above that may be associated with cut/waste, ditch pulling, and shoulder cutting.
2. Plants with roots including grass sod.
3. Plant crowns and roots.
4. Bulbs, corms, rhizomes, and tubers of ornamental plants.
5. Hay, straw, fodder, and plant litter of any kind.
6. Clearing and grubbing debris.
7. Used agricultural cultivating and harvesting equipment.
8. Used earth-moving equipment.
9. Any other products, articles, or means of conveyance, of any character, if determined by an inspector to present a hazard of spreading imported fire ant, gypsy moth, witchweed, emerald ash borer, or other noxious weeds.

**STANDARD SPECIAL PROVISION****AWARD OF CONTRACT**

(6-28-77)(Rev 2/16/2016)

Z-6

“The North Carolina Department of Transportation, in accordance with the provisions of *Title VI of the Civil Rights Act of 1964* (78 Stat. 252) and the Regulations of the Department of Transportation (*49 C.F.R., Part 21*), issued pursuant to such act, hereby notifies all bidders that it will affirmatively insure that the contract entered into pursuant to this advertisement will be awarded to the lowest responsible bidder without discrimination on the ground of race, color, or national origin”.

**TITLE VI AND NONDISCRIMINATION****I. Title VI Assurance**

During the performance of this contract, the contractor, for itself, its assignees and successors in interest (hereinafter referred to as the "contractor") agrees as follows:

**(1) Compliance with Regulations:** The contractor shall comply with the Regulation relative to nondiscrimination in Federally-assisted programs of the Department of Transportation (hereinafter, "DOT") Title 49, Code of Federal Regulations, Part 21, as they may be amended from time to time, (hereinafter referred to as the Regulations), which are herein incorporated by reference and made a part of this contract.

**(2) Nondiscrimination:** The Contractor, with regard to the work performed by it during the contract, shall not discriminate on the grounds of race, color, or national origin in the selection and retention of subcontractors, including procurements of materials and leases of equipment. The contractor shall not participate either directly or indirectly in the discrimination prohibited by section 21.5 of the Regulations, including employment practices when the contract covers a program set forth in Appendix B of the Regulations.

**(3) Solicitations for Subcontractors, Including Procurements of Materials and Equipment:** In all solicitations either by competitive bidding or negotiation made by the contractor for work to be performed under a subcontract, including procurements of materials or leases of equipment, each potential subcontractor or supplier shall be notified by the contractor of the contractor's obligations under this contract and the Regulations relative to nondiscrimination on the grounds of race, color, or national origin.

**(4) Information and Reports:** The contractor shall provide all information and reports required by the Regulations or directives issued pursuant thereto, and shall permit access to its books, records, accounts, other sources of information, and its facilities as may be determined by the North Carolina Department of Transportation (NCDOT) or the Federal Highway Administration (FHWA) to be pertinent to ascertain compliance with such Regulations, orders and instructions. Where any information required of a contractor is in the exclusive possession of another who fails or refuses to furnish this information the contractor shall so certify to the NCDOT, or the FHWA as appropriate, and shall set forth what efforts it has made to obtain the information.



**(5) Sanctions for Noncompliance:** In the event of the contractor's noncompliance with the nondiscrimination provisions of this contract, the NCDOT shall impose such contract sanctions as it or the FHWA may determine to be appropriate, including, but not limited to:

(a) Withholding of payments to the contractor under the contract until the contractor complies, and/or

(b) Cancellation, termination or suspension of the contract, in whole or in part.

**(6) Incorporation of Provisions:** The contractor shall include the provisions of paragraphs (1) through (6) in every subcontract, including procurements of materials and leases of equipment, unless exempt by the Regulations, or directives issued pursuant thereto.

The contractor shall take such action with respect to any subcontractor procurement as the NCDOT or the FHWA may direct as a means of enforcing such provisions including sanctions for noncompliance: provided, however, that, in the event a contractor becomes involved in, or is threatened with, litigation with a subcontractor or supplier as a result of such direction, the contractor may request the NCDOT to enter into such litigation to protect the interests of the NCDOT, and, in addition, the contractor may request the United States to enter into such litigation to protect the interests of the United States.

## **II. Title VI Nondiscrimination Program**

Title VI of the 1964 Civil Rights Act, 42 U.S.C. 2000d, provides that: "No person in the United States shall, on the grounds of race, color, or national origin, be excluded from participation in, be denied the benefits of, or be subjected to discrimination under any program or activity receiving Federal financial assistance." The broader application of nondiscrimination law is found in other statutes, executive orders, and regulations (see Section III, Pertinent Nondiscrimination Authorities), which provide additional protections based on age, sex, disability and religion. In addition, the 1987 Civil Rights Restoration Act extends nondiscrimination coverage to all programs and activities of federal-aid recipients and contractors, including those that are not federally-funded.

### *Nondiscrimination Assurance*

The North Carolina Department of Transportation (NCDOT) hereby gives assurance that no person shall on the ground of race, color, national origin, sex, age, and disability, be excluded from participation in, be denied the benefits of, or be otherwise subjected to discrimination under any program or activity conducted by the recipient, as provided by Title VI of the Civil Rights Act of 1964, the Civil Rights Restoration Act of 1987, and any other related Civil Rights authorities, whether those programs and activities are federally funded or not.

### *Obligation*

During the performance of this contract, the Contractor and its subcontractors are responsible for complying with NCDOT's Title VI Program. The Contractor must ensure that NCDOT's Notice of Nondiscrimination is posted in conspicuous locations accessible to all employees and subcontractors on the jobsite, along with the Contractor's own Equal Employment Opportunity (EEO) Policy Statement. The Contractor shall physically incorporate this "**TITLE VI AND NONDISCRIMINATION**" language, in its entirety, into all its subcontracts on federally-assisted and state-funded NCDOT-owned projects, and ensure its inclusion by subcontractors into all subsequent lower tier subcontracts. The Contractor and its subcontractors shall also physically incorporate the **FHWA-1273**, in its entirety, into all subcontracts and subsequent lower tier subcontracts on Federal-aid highway construction contracts only. The Contractor is also responsible for making its subcontractors aware of NCDOT's Discrimination Complaints Process, as follows:

**FILING OF COMPLAINTS**

1. **Applicability** – These complaint procedures apply to the beneficiaries of the NCDOT's programs, activities, and services, including, but not limited to, members of the public, contractors, subcontractors, consultants, and other sub-recipients of federal and state funds.
2. **Eligibility** – Any person or class of persons who believes he/she has been subjected to discrimination or retaliation prohibited by any of the Civil Rights authorities, based upon race, color, sex, age, national origin, or disability, may file a written complaint with NCDOT's Civil Rights office. The law prohibits intimidation or retaliation of any sort. The complaint may be filed by the affected individual or a representative, and must be in writing.
3. **Time Limits and Filing Options** – A complaint must be filed no later than 180 calendar days after the following:
  - The date of the alleged act of discrimination; or
  - The date when the person(s) became aware of the alleged discrimination; or
  - Where there has been a continuing course of conduct, the date on which that conduct was discontinued or the latest instance of the conduct.

Title VI and other discrimination complaints may be submitted to the following entities:

- **North Carolina Department of Transportation**, Office of Equal Opportunity & Workforce Services (EOWS), External Civil Rights Section, 1511 Mail Service Center, Raleigh, NC 27699-1511; 919-508-1808 or toll free 800-522-0453
- **US Department of Transportation**, Departmental Office of Civil Rights, External Civil Rights Programs Division, 1200 New Jersey Avenue, SE, Washington, DC 20590; 202-366-4070
  - Federal Highway Administration**, North Carolina Division Office, 310 New Bern Avenue, Suite 410, Raleigh, NC 27601, 919-747-7010
  - Federal Highway Administration**, Office of Civil Rights, 1200 New Jersey Avenue, SE, 8<sup>th</sup> Floor, E81-314, Washington, DC 20590, 202-366-0693 / 366-0752
  - Federal Transit Administration**, Office of Civil Rights, ATTN: Title VI Program Coordinator, East Bldg. 5<sup>th</sup> Floor – TCR, 1200 New Jersey Avenue, SE, Washington, DC 20590
  - Federal Aviation Administration**, Office of Civil Rights, 800 Independence Avenue, SW, Washington, DC 20591, 202-267-3258
- **US Department of Justice**, Special Litigation Section, Civil Rights Division, 950 Pennsylvania Avenue, NW, Washington, DC 20530, 202-514-6255 or toll free 877-218-5228

4. **Format for Complaints** – Complaints must be in **writing** and **signed** by the complainant(s) or a representative and include the complainant's name, address, and telephone number. Complaints received by fax or e-mail will be acknowledged and processed. Allegations received by telephone will be reduced to writing and provided to the complainant for confirmation or revision before processing. Complaints will be accepted in other languages including Braille.
5. **Discrimination Complaint Form** – Contact NCDOT EOWS at the phone number above to receive a full copy of the Discrimination Complaint Form and procedures.
6. **Complaint Basis** – Allegations must be based on issues involving race, color, national origin, sex, age, or disability. The term “basis” refers to the complainant's membership in a protected group category. Contact this office to receive a Discrimination Complaint Form.

Protected Categories	Definition	Examples	Applicable Statutes and Regulations	
			FHWA	FTA
Race	An individual belonging to one of the accepted racial groups; or the perception, based usually on physical characteristics that a person is a member of a racial group	Black/African American, Hispanic/Latino, Asian, American Indian/Alaska Native, Native Hawaiian/Pacific Islander, White	Title VI of the Civil Rights Act of 1964; 49 CFR Part 21; 23 CFR 200	Title VI of the Civil Rights Act of 1964; 49 CFR Part 21; Circular 4702.1B
Color	Color of skin, including shade of skin within a racial group	Black, White, brown, yellow, etc.		
National Origin	Place of birth. Citizenship is not a factor. Discrimination based on language or a person's accent is also covered.	Mexican, Cuban, Japanese, Vietnamese, Chinese		
Sex	Gender	Women and Men	1973 Federal-Aid Highway Act	Title IX of the Education Amendments of 1972
Age	Persons of any age	21 year old person	Age Discrimination Act of 1975	
Disability	Physical or mental impairment, permanent or temporary, or perceived.	Blind, alcoholic, paraplegic, epileptic, diabetic, arthritic	Section 504 of the Rehabilitation Act of 1973; Americans with Disabilities Act of 1990	

### III. Pertinent Nondiscrimination Authorities

During the performance of this contract, the contractor, for itself, its assignees, and successors in interest agrees to comply with the following non-discrimination statutes and authorities, including, but not limited to:

- Title VI of the Civil Rights Act of 1964 (42 U.S.C. § 2000d *et seq.*, 78 stat. 252), (prohibits discrimination on the basis of race, color, national origin); and 49 CFR Part 21.
- The Uniform Relocation Assistance and Real Property Acquisition Policies Act of 1970, (42 U.S.C. § 4601), (prohibits unfair treatment of persons displaced or whose property has been acquired because of Federal or Federal-aid programs and projects);
- Federal-Aid Highway Act of 1973, (23 U.S.C. § 324 *et seq.*), (prohibits discrimination on the basis of sex);
- Section 504 of the Rehabilitation Act of 1973, (29 U.S.C. § 794 *et seq.*), as amended, (prohibits discrimination on the basis of disability); and 49 CFR Part 27;
- The Age Discrimination Act of 1975, as amended, (42 U.S.C. § 6101 *et seq.*), (prohibits discrimination on the basis of age);
- Airport and Airway Improvement Act of 1982, (49 USC § 471, Section 47123), as amended, (prohibits discrimination based on race, creed, color, national origin, or sex);
- The Civil Rights Restoration Act of 1987, (PL 100-209), (Broadened the scope, coverage and applicability of Title VI of the Civil Rights Act of 1964, The Age Discrimination Act of 1975 and Section 504 of the Rehabilitation Act of 1973, by expanding the definition of the terms

“programs or activities” to include all of the programs or activities of the Federal-aid recipients, sub-recipients and contractors, whether such programs or activities are Federally funded or not);

- Titles II and III of the Americans with Disabilities Act, which prohibit discrimination on the basis of disability in the operation of public entities, public and private transportation systems, places of public accommodation, and certain testing entities (42 U.S.C. §§ 12131 – 12189) as implemented by Department of Transportation regulations at 49 C.F.R. parts 37 and 38;
- The Federal Aviation Administration’s Non-discrimination statute (49 U.S.C. § 47123) (prohibits discrimination on the basis of race, color, national origin, and sex);
- Executive Order 12898, Federal Actions to Address Environmental Justice in Minority Populations and Low-Income Populations, which ensures discrimination against minority populations by discouraging programs, policies, and activities with disproportionately high and adverse human health or environmental effects on minority and low-income populations;
- Executive Order 13166, Improving Access to Services for Persons with Limited English Proficiency, and resulting agency guidance, national origin discrimination includes discrimination because of limited English proficiency (LEP). To ensure compliance with Title VI, you must take reasonable steps to ensure that LEP persons have meaningful access to your programs (70 Fed. Reg. at 74087 to 74100);
- Title IX of the Education Amendments of 1972, as amended, which prohibits you from discriminating because of sex in education programs or activities (20 U.S.C. 1681 et seq).
- Title VII of the Civil Rights Act of 1964 (42 U.S.C. § 2000e *et seq.*, Pub. L. 88-352), (prohibits employment discrimination on the basis of race, color, religion, sex, or national origin);
- 49 CFR Part 26, regulation to ensure nondiscrimination in the award and administration of DOT-assisted contracts in the Department's highway, transit, and airport financial assistance programs, as regards the use of Disadvantaged Business Enterprises (DBEs);
- Form FHWA-1273, “Required Contract Provisions,” a collection of contract provisions and proposal notices that are generally applicable to *all Federal-aid construction projects* and must be made a part of, and physically incorporated into, *all federally-assisted contracts*, as well as appropriate subcontracts and purchase orders, particularly Sections II (Nondiscrimination) and III (Nonsegregated Facilities).

**STANDARD SPECIAL PROVISION****MINORITY AND FEMALE EMPLOYMENT REQUIREMENTS**

Z-7

**NOTICE OF REQUIREMENTS FOR AFFIRMATIVE ACTION TO ENSURE EQUAL EMPLOYMENT OPPORTUNITY (*EXECUTIVE NUMBER 11246*)**

1. The goals and timetables for minority and female participation, expressed in percentage terms for the Contractor's aggregate workforce in each trade on all construction work in the covered area, see as shown on the attached sheet entitled "Employment Goals for Minority and Female participation".

These goals are applicable to all the Contractor's construction work (whether or not it is Federal or federally assisted) performed in the covered area. If the Contractor performs construction work in a geographical area located outside of the covered area, it shall apply the goals established for such geographical area where the work is actually performed. With regard to this second area, the Contractor also is subject to the goals for both its federally involved and nonfederally involved construction.

The Contractor's compliance with the Executive Order and the regulations in *41 CFR Part 60-4* shall be based on its implementation of the Equal Opportunity Clause, specific affirmative action obligations required by the specifications set forth in *41 CFR 60-4.3(a)*, and its effort to meet the goals. The hours of minority and female employment and training must be substantially uniform throughout the length of the contract, and in each trade and the Contractor shall make a good faith effort to employ minorities and women evenly on each of its projects. The transfer of minority or female employees or trainees from Contractor to Contractor or from project to project for the sole purpose of meeting the Contractor's goals shall be a violation of the contract, the executive Order and the regulations in *41 CFR Part 60-4*. Compliance with the goals will be measured against the total work hours performed.

2. As used in this Notice and in the contract resulting from this solicitation, the "covered area" is the county or counties shown on the cover sheet of the proposal form and contract.

**EMPLOYMENT GOALS FOR MINORITY  
AND FEMALE PARTICIPATION**

Economic Areas

**Area 023 29.7%**

Bertie County  
Camden County  
Chowan County  
Gates County  
Hertford County  
Pasquotank County  
Perquimans County

**Area 024 31.7%**

Beaufort County  
Carteret County  
Craven County  
Dare County  
Edgecombe County  
Green County  
Halifax County  
Hyde County  
Jones County  
Lenoir County  
Martin County  
Nash County  
Northampton County  
Pamlico County  
Pitt County  
Tyrrell County  
Washington County  
Wayne County  
Wilson County

**Area 025 23.5%**

Columbus County  
Duplin County  
Onslow County  
Pender County

**Area 026 33.5%**

Bladen County  
Hoke County  
Richmond County  
Robeson County  
Sampson County  
Scotland County

**Area 027 24.7%**

Chatham County  
Franklin County  
Granville County  
Harnett County  
Johnston County  
Lee County  
Person County  
Vance County  
Warren County

**Area 028 15.5%**

Alleghany County  
Ashe County  
Caswell County  
Davie County  
Montgomery County  
Moore County  
Rockingham County  
Surry County  
Watauga County  
Wilkes County

**Area 029 15.7%**

Alexander County  
Anson County  
Burke County  
Cabarrus County  
Caldwell County  
Catawba County  
Cleveland County  
Iredell County  
Lincoln County  
Polk County  
Rowan County  
Rutherford County  
Stanly County

**Area 0480 8.5%**

Buncombe County  
Madison County

**Area 030 6.3%**

Avery County  
Cherokee County  
Clay County  
Graham County  
Haywood County  
Henderson County  
Jackson County  
McDowell County  
Macon County  
Mitchell County  
Swain County  
Transylvania County  
Yancey County

**SMSA Areas**

**Area 5720 26.6%**  
Currituck County

**Area 9200 20.7%**  
Brunswick County  
New Hanover County

**Area 2560 24.2%**  
Cumberland County

**Area 6640 22.8%**  
Durham County  
Orange County  
Wake County

**Area 1300 16.2%**  
Alamance County

**Area 3120 16.4%**  
Davidson County  
Forsyth County  
Guilford County  
Randolph County  
Stokes County  
Yadkin County

**Area 1520 18.3%**  
Gaston County  
Mecklenburg County  
Union County

---

**Goals for Female**

**Participation in Each Trade**

(Statewide) 6.9%

**STANDARD SPECIAL PROVISION****REQUIRED CONTRACT PROVISIONS FEDERAL - AID CONSTRUCTION CONTRACTS**

FHWA - 1273 Electronic Version - May 1, 2012

Z-8

- I. General
- II. Nondiscrimination
- III. Nonsegregated Facilities
- IV. Davis-Bacon and Related Act Provisions
- V. Contract Work Hours and Safety Standards Act Provisions
- VI. Subletting or Assigning the Contract
- VII. Safety: Accident Prevention
- VIII. False Statements Concerning Highway Projects
- IX. Implementation of Clean Air Act and Federal Water Pollution Control Act
- X. Compliance with Governmentwide Suspension and Debarment Requirements
- XI. Certification Regarding Use of Contract Funds for Lobbying

**ATTACHMENTS**

- A. Employment and Materials Preference for Appalachian Development Highway System or Appalachian Local Access Road Contracts (included in Appalachian contracts only)

**I. GENERAL**

1. Form FHWA-1273 must be physically incorporated in each construction contract funded under Title 23 (excluding emergency contracts solely intended for debris removal). The contractor (or subcontractor) must insert this form in each subcontract and further require its inclusion in all lower tier subcontracts (excluding purchase orders, rental agreements and other agreements for supplies or services).  
The applicable requirements of Form FHWA-1273 are incorporated by reference for work done under any purchase order, rental agreement or agreement for other services. The prime contractor shall be responsible for compliance by any subcontractor, lower-tier subcontractor or service provider.  
Form FHWA-1273 must be included in all Federal-aid design-build contracts, in all subcontracts and in lower tier subcontracts (excluding subcontracts for design services, purchase orders, rental agreements and other agreements for supplies or services). The design-builder shall be responsible for compliance by any subcontractor, lower-tier subcontractor or service provider.  
Contracting agencies may reference Form FHWA-1273 in bid proposal or request for proposal documents, however, the Form FHWA-1273 must be physically incorporated (not referenced) in all contracts, subcontracts and lower-tier subcontracts (excluding purchase orders, rental agreements and other agreements for supplies or services related to a construction contract).
2. Subject to the applicability criteria noted in the following sections, these contract provisions shall apply to all work performed on the contract by the contractor's own organization and with the assistance of workers under the contractor's immediate superintendence and to all work performed on the contract by piecework, station work, or by subcontract.
3. A breach of any of the stipulations contained in these Required Contract Provisions may be sufficient grounds for withholding of progress payments, withholding of final payment, termination of the contract, suspension / debarment or any other action determined to be appropriate by the contracting agency and FHWA.
4. Selection of Labor: During the performance of this contract, the contractor shall not use convict labor for any purpose within the limits of a construction project on a Federal-aid highway unless it is labor performed by convicts who are on parole, supervised release, or probation. The term Federal-aid highway does not include roadways functionally classified as local roads or rural minor collectors.

**II. NONDISCRIMINATION**

The provisions of this section related to 23 CFR Part 230 are applicable to all Federal-aid construction contracts and to all related construction subcontracts of \$10,000 or more. The provisions of 23 CFR Part 230 are not applicable to material supply, engineering, or architectural service contracts.

In addition, the contractor and all subcontractors must comply with the following policies: Executive Order 11246, 41 CFR 60, 29 CFR 1625-1627, Title 23 USC Section 140, the Rehabilitation Act of 1973, as amended (29 USC 794), Title VI of the Civil Rights Act of 1964, as amended, and related regulations including 49 CFR Parts 21, 26 and 27; and 23 CFR Parts 200, 230, and 633.

The contractor and all subcontractors must comply with: the requirements of the Equal Opportunity Clause in 41 CFR 60-1.4(b) and, for all construction contracts exceeding \$10,000, the Standard Federal Equal Employment Opportunity Construction Contract Specifications in 41 CFR 60-4.3.

Note: The U.S. Department of Labor has exclusive authority to determine compliance with Executive Order 11246 and the policies of the Secretary of Labor including 41 CFR 60, and 29 CFR 1625-1627. The contracting agency and the FHWA have the authority and the responsibility to ensure compliance with Title 23 USC Section 140, the Rehabilitation Act of 1973, as amended (29 USC 794), and Title VI of the Civil Rights Act of 1964, as amended, and related regulations including 49 CFR Parts 21, 26 and 27; and 23 CFR Parts 200, 230, and 633.

The following provision is adopted from 23 CFR 230, Appendix A, with appropriate revisions to conform to the U.S. Department of Labor (US DOL) and FHWA requirements.

1. **Equal Employment Opportunity:** Equal employment opportunity (EEO) requirements not to discriminate and to take affirmative action to assure equal opportunity as set forth under laws, executive orders, rules, regulations (28 CFR 35, 29 CFR 1630, 29 CFR 1625-1627, 41 CFR 60 and 49 CFR 27) and orders of the Secretary of Labor as modified by the provisions prescribed herein, and imposed pursuant to 23 U.S.C. 140 shall constitute the EEO and specific affirmative action standards for the contractor's project activities under this contract. The provisions of the Americans with Disabilities Act of 1990 (42 U.S.C. 12101 et seq.) set forth under 28 CFR 35 and 29 CFR 1630 are incorporated by reference in this contract. In the execution of this contract, the contractor agrees to comply with the following minimum specific requirement activities of EEO:
  - a. The contractor will work with the contracting agency and the Federal Government to ensure that it has made every good faith effort to provide equal opportunity with respect to all of its terms and conditions of employment and in their review of activities under the contract.
  - b. The contractor will accept as its operating policy the following statement:



"It is the policy of this Company to assure that applicants are employed, and that employees are treated during employment, without regard to their race, religion, sex, color, national origin, age or disability. Such action shall include: employment, upgrading, demotion, or transfer; recruitment or recruitment advertising; layoff or termination; rates of pay or other forms of compensation; and selection for training, including apprenticeship, pre-apprenticeship, and/or on-the-job training."

2. **EEO Officer:** The contractor will designate and make known to the contracting officers an EEO Officer who will have the responsibility for and must be capable of effectively administering and promoting an active EEO program and who must be assigned adequate authority and responsibility to do so.
3. **Dissemination of Policy:** All members of the contractor's staff who are authorized to hire, supervise, promote, and discharge employees, or who recommend such action, or who are substantially involved in such action, will be made fully cognizant of, and will implement, the contractor's EEO policy and contractual responsibilities to provide EEO in each grade and classification of employment. To ensure that the above agreement will be met, the following actions will be taken as a minimum:
  - a. Periodic meetings of supervisory and personnel office employees will be conducted before the start of work and then not less often than once every six months, at which time the contractor's EEO policy and its implementation will be reviewed and explained. The meetings will be conducted by the EEO Officer.
  - b. All new supervisory or personnel office employees will be given a thorough indoctrination by the EEO Officer, covering all major aspects of the contractor's EEO obligations within thirty days following their reporting for duty with the contractor.
  - c. All personnel who are engaged in direct recruitment for the project will be instructed by the EEO Officer in the contractor's procedures for locating and hiring minorities and women.
  - d. Notices and posters setting forth the contractor's EEO policy will be placed in areas readily accessible to employees, applicants for employment and potential employees.
  - e. The contractor's EEO policy and the procedures to implement such policy will be brought to the attention of employees by means of meetings, employee handbooks, or other appropriate means.
4. **Recruitment:** When advertising for employees, the contractor will include in all advertisements for employees the notation: "An Equal Opportunity Employer." All such advertisements will be placed in publications having a large circulation among minorities and women in the area from which the project work force would normally be derived.
  - a. The contractor will, unless precluded by a valid bargaining agreement, conduct systematic and direct recruitment through public and private employee referral sources likely to yield qualified minorities and women. To meet this requirement, the contractor will identify sources of potential minority group employees, and establish with such identified sources procedures whereby minority and women applicants may be referred to the contractor for employment consideration.
  - b. In the event the contractor has a valid bargaining agreement providing for exclusive hiring hall referrals, the contractor is expected to observe the provisions of that agreement to the extent that the system meets the contractor's compliance with EEO contract provisions. Where implementation of such an agreement has the effect of discriminating against minorities or women, or obligates the contractor to do the same, such implementation violates Federal nondiscrimination provisions.
  - c. The contractor will encourage its present employees to refer minorities and women as applicants for employment. Information and procedures with regard to referring such applicants will be discussed with employees.
5. **Personnel Actions:** Wages, working conditions, and employee benefits shall be established and administered, and personnel actions of every type, including hiring, upgrading, promotion, transfer, demotion, layoff, and termination, shall be taken without regard to race, color, religion, sex, national origin, age or disability. The following procedures shall be followed:
  - a. The contractor will conduct periodic inspections of project sites to insure that working conditions and employee facilities do not indicate discriminatory treatment of project site personnel.
  - b. The contractor will periodically evaluate the spread of wages paid within each classification to determine any evidence of discriminatory wage practices.
  - c. The contractor will periodically review selected personnel actions in depth to determine whether there is evidence of discrimination. Where evidence is found, the contractor will promptly take corrective action. If the review indicates that the discrimination may extend beyond the actions reviewed, such corrective action shall include all affected persons.
  - d. The contractor will promptly investigate all complaints of alleged discrimination made to the contractor in connection with its obligations under this contract, will attempt to resolve such complaints, and will take appropriate corrective action within a reasonable time. If the investigation indicates that the discrimination may affect persons other than the complainant, such corrective action shall include such other persons. Upon completion of each investigation, the contractor will inform every complainant of all of their avenues of appeal.
6. **Training and Promotion:**
  - a. The contractor will assist in locating, qualifying, and increasing the skills of minorities and women who are applicants for employment or current employees. Such efforts should be aimed at developing full journey level status employees in the type of trade or job classification involved.
  - b. Consistent with the contractor's work force requirements and as permissible under Federal and State regulations, the contractor shall make full use of training programs, i.e., apprenticeship, and on-the-job training programs for the geographical area of contract performance. In the event a special provision for training is provided under this contract, this subparagraph will be superseded as indicated in the special provision. The contracting agency may reserve training positions for persons who receive welfare assistance in accordance with 23 U.S.C. 140(a).
  - c. The contractor will advise employees and applicants for employment of available training programs and entrance requirements for each.
  - d. The contractor will periodically review the training and promotion potential of employees who are minorities and women and will encourage eligible employees to apply for such training and promotion.
7. **Unions:** If the contractor relies in whole or in part upon unions as a source of employees, the contractor will use good faith efforts to obtain the cooperation of such unions to increase opportunities for minorities and women. Actions by the contractor, either directly or through a contractor's association acting as agent, will include the procedures set forth below:
  - a. The contractor will use good faith efforts to develop, in cooperation with the unions, joint training programs aimed toward qualifying more minorities and women for membership in the unions and increasing the skills of minorities and women so that they may qualify for higher paying employment.
  - b. The contractor will use good faith efforts to incorporate an EEO clause into each union agreement to the end that such union will be contractually bound to refer applicants without regard to their race, color, religion, sex, national origin, age or disability.
  - c. The contractor is to obtain information as to the referral practices and policies of the labor union except that to the extent such information is within the exclusive possession of the labor union and such labor union refuses to furnish such information to the contractor, the contractor shall so certify to the contracting agency and shall set forth what efforts have been made to obtain such information.

- d. In the event the union is unable to provide the contractor with a reasonable flow of referrals within the time limit set forth in the collective bargaining agreement, the contractor will, through independent recruitment efforts, fill the employment vacancies without regard to race, color, religion, sex, national origin, age or disability; making full efforts to obtain qualified and/or qualifiable minorities and women. The failure of a union to provide sufficient referrals (even though it is obligated to provide exclusive referrals under the terms of a collective bargaining agreement) does not relieve the contractor from the requirements of this paragraph. In the event the union referral practice prevents the contractor from meeting the obligations pursuant to Executive Order 11246, as amended, and these special provisions, such contractor shall immediately notify the contracting agency.
8. **Reasonable Accommodation for Applicants / Employees with Disabilities:** The contractor must be familiar with the requirements for and comply with the Americans with Disabilities Act and all rules and regulations established there under. Employers must provide reasonable accommodation in all employment activities unless to do so would cause an undue hardship.
9. **Selection of Subcontractors, Procurement of Materials and Leasing of Equipment:** The contractor shall not discriminate on the grounds of race, color, religion, sex, national origin, age or disability in the selection and retention of subcontractors, including procurement of materials and leases of equipment. The contractor shall take all necessary and reasonable steps to ensure nondiscrimination in the administration of this contract.
- The contractor shall notify all potential subcontractors and suppliers and lessors of their EEO obligations under this contract.
  - The contractor will use good faith efforts to ensure subcontractor compliance with their EEO obligations.
10. **Assurance Required by 49 CFR 26.13(b):**
- The requirements of 49 CFR Part 26 and the State DOT's U.S. DOT-approved DBE program are incorporated by reference.
  - The contractor or subcontractor shall not discriminate on the basis of race, color, national origin, or sex in the performance of this contract. The contractor shall carry out applicable requirements of 49 CFR Part 26 in the award and administration of DOT-assisted contracts. Failure by the contractor to carry out these requirements is a material breach of this contract, which may result in the termination of this contract or such other remedy as the contracting agency deems appropriate.
11. **Records and Reports:** The contractor shall keep such records as necessary to document compliance with the EEO requirements. Such records shall be retained for a period of three years following the date of the final payment to the contractor for all contract work and shall be available at reasonable times and places for inspection by authorized representatives of the contracting agency and the FHWA.
- The records kept by the contractor shall document the following:
    - The number and work hours of minority and non-minority group members and women employed in each work classification on the project;
    - The progress and efforts being made in cooperation with unions, when applicable, to increase employment opportunities for minorities and women; and
    - The progress and efforts being made in locating, hiring, training, qualifying, and upgrading minorities and women;
  - The contractors and subcontractors will submit an annual report to the contracting agency each July for the duration of the project, indicating the number of minority, women, and non-minority group employees currently engaged in each work classification required by the contract work. This information is to be reported on Form FHWA-1391. The staffing data should represent the project work force on board in all or any part of the last payroll period preceding the end of July. If on-the-job training is being required by special provision, the contractor will be required to collect and report training data. The employment data should reflect the work force on board during all or any part of the last payroll period preceding the end of July.

### III. NONSEGREGATED FACILITIES

This provision is applicable to all Federal-aid construction contracts and to all related construction subcontracts of \$10,000 or more.

The contractor must ensure that facilities provided for employees are provided in such a manner that segregation on the basis of race, color, religion, sex, or national origin cannot result. The contractor may neither require such segregated use by written or oral policies nor tolerate such use by employee custom. The contractor's obligation extends further to ensure that its employees are not assigned to perform their services at any location, under the contractor's control, where the facilities are segregated. The term "facilities" includes waiting rooms, work areas, restaurants and other eating areas, time clocks, restrooms, washrooms, locker rooms, and other storage or dressing areas, parking lots, drinking fountains, recreation or entertainment areas, transportation, and housing provided for employees. The contractor shall provide separate or single-user restrooms and necessary dressing or sleeping areas to assure privacy between sexes.

### IV. DAVIS-BACON AND RELATED ACT PROVISIONS

This section is applicable to all Federal-aid construction projects exceeding \$2,000 and to all related subcontracts and lower-tier subcontracts (regardless of subcontract size). The requirements apply to all projects located within the right-of-way of a roadway that is functionally classified as Federal-aid highway. This excludes roadways functionally classified as local roads or rural minor collectors, which are exempt. Contracting agencies may elect to apply these requirements to other projects.

The following provisions are from the U.S. Department of Labor regulations in 29 CFR 5.5 "Contract provisions and related matters" with minor revisions to conform to the FHWA-1273 format and FHWA program requirements.

#### 1. Minimum wages

- All laborers and mechanics employed or working upon the site of the work, will be paid unconditionally and not less often than once a week, and without subsequent deduction or rebate on any account (except such payroll deductions as are permitted by regulations issued by the Secretary of Labor under the Copeland Act (29 CFR part 3)), the full amount of wages and bona fide fringe benefits (or cash equivalents thereof) due at time of payment computed at rates not less than those contained in the wage determination of the Secretary of Labor which is attached hereto and made a part hereof, regardless of any contractual relationship which may be alleged to exist between the contractor and such laborers and mechanics.

Contributions made or costs reasonably anticipated for bona fide fringe benefits under section 1(b)(2) of the Davis-Bacon Act on behalf of laborers or mechanics are considered wages paid to such laborers or mechanics, subject to the provisions of paragraph 1.d. of this section; also, regular contributions made or costs incurred for more than a weekly period (but not less often than quarterly) under plans, funds, or programs which cover the particular weekly period, are deemed to be constructively made or incurred during such weekly period. Such laborers and mechanics shall be paid the appropriate wage rate and fringe benefits on the wage determination for the classification of work actually performed, without regard to skill, except as provided in 29 CFR 5.5(a)(4). Laborers or mechanics performing work in more than one classification may be compensated at the rate specified for each classification for the time actually worked therein: Provided, That the employer's payroll records accurately set forth the time spent in each classification in which work is performed. The wage determination (including any additional classification and wage rates conformed under paragraph 1.b. of this section) and the Davis-Bacon poster (WH-1321) shall be posted at all times by the contractor and its subcontractors at the site of the work in a prominent and accessible place where it can be easily seen by the workers.

- b. (1) The contracting officer shall require that any class of laborers or mechanics, including helpers, which is not listed in the wage determination and which is to be employed under the contract shall be classified in conformance with the wage determination. The contracting officer shall approve an additional classification and wage rate and fringe benefits therefore only when the following criteria have been met:
  - (i) The work to be performed by the classification requested is not performed by a classification in the wage determination; and
  - (ii) The classification is utilized in the area by the construction industry; and
  - (iii) The proposed wage rate, including any bona fide fringe benefits, bears a reasonable relationship to the wage rates contained in the wage determination.
- (2) If the contractor and the laborers and mechanics to be employed in the classification (if known), or their representatives, and the contracting officer agree on the classification and wage rate (including the amount designated for fringe benefits where appropriate), a report of the action taken shall be sent by the contracting officer to the Administrator of the Wage and Hour Division, Employment Standards Administration, U.S. Department of Labor, Washington, DC 20210. The Administrator, or an authorized representative, will approve, modify, or disapprove every additional classification action within 30 days of receipt and so advise the contracting officer or will notify the contracting officer within the 30-day period that additional time is necessary.
- (3) In the event the contractor, the laborers or mechanics to be employed in the classification or their representatives, and the contracting officer do not agree on the proposed classification and wage rate (including the amount designated for fringe benefits, where appropriate), the contracting officer shall refer the questions, including the views of all interested parties and the recommendation of the contracting officer, to the Wage and Hour Administrator for determination. The Wage and Hour Administrator, or an authorized representative, will issue a determination within 30 days of receipt and so advise the contracting officer or will notify the contracting officer within the 30-day period that additional time is necessary.
- (4) The wage rate (including fringe benefits where appropriate) determined pursuant to paragraphs 1.b.(2) or 1.b.(3) of this section, shall be paid to all workers performing work in the classification under this contract from the first day on which work is performed in the classification.
- c. Whenever the minimum wage rate prescribed in the contract for a class of laborers or mechanics includes a fringe benefit which is not expressed as an hourly rate, the contractor shall either pay the benefit as stated in the wage determination or shall pay another bona fide fringe benefit or an hourly cash equivalent thereof.
- d. If the contractor does not make payments to a trustee or other third person, the contractor may consider as part of the wages of any laborer or mechanic the amount of any costs reasonably anticipated in providing bona fide fringe benefits under a plan or program. Provided, That the Secretary of Labor has found, upon the written request of the contractor, that the applicable standards of the Davis-Bacon Act have been met. The Secretary of Labor may require the contractor to set aside in a separate account assets for the meeting of obligations under the plan or program.
2. **Withholding.** The contracting agency shall upon its own action or upon written request of an authorized representative of the Department of Labor, withhold or cause to be withheld from the contractor under this contract, or any other Federal contract with the same prime contractor, or any other federally-assisted contract subject to Davis-Bacon prevailing wage requirements, which is held by the same prime contractor, so much of the accrued payments or advances as may be considered necessary to pay laborers and mechanics, including apprentices, trainees, and helpers, employed by the contractor or any subcontractor the full amount of wages required by the contract. In the event of failure to pay any laborer or mechanic, including any apprentice, trainee, or helper, employed or working on the site of the work, all or part of the wages required by the contract, the contracting agency may, after written notice to the contractor, take such action as may be necessary to cause the suspension of any further payment, advance, or guarantee of funds until such violations have ceased.
3. **Payrolls and basic records**
  - a. Payrolls and basic records relating thereto shall be maintained by the contractor during the course of the work and preserved for a period of three years thereafter for all laborers and mechanics working at the site of the work. Such records shall contain the name, address, and social security number of each such worker, his or her correct classification, hourly rates of wages paid (including rates of contributions or costs anticipated for bona fide fringe benefits or cash equivalents thereof of the types described in section 1(b)(2)(B) of the Davis-Bacon Act), daily and weekly number of hours worked, deductions made and actual wages paid. Whenever the Secretary of Labor has found under 29 CFR 5.5(a)(1)(iv) that the wages of any laborer or mechanic include the amount of any costs reasonably anticipated in providing benefits under a plan or program described in section 1(b)(2)(B) of the Davis-Bacon Act, the contractor shall maintain records which show that the commitment to provide such benefits is enforceable, that the plan or program is financially responsible, and that the plan or program has been communicated in writing to the laborers or mechanics affected, and records which show the costs anticipated or the actual cost incurred in providing such benefits. Contractors employing apprentices or trainees under approved programs shall maintain written evidence of the registration of apprenticeship programs and certification of trainee programs, the registration of the apprentices and trainees, and the ratios and wage rates prescribed in the applicable programs.
  - b. (1) The contractor shall submit weekly for each week in which any contract work is performed a copy of all payrolls to the contracting agency. The payrolls submitted shall set out accurately and completely all of the information required to be maintained under 29 CFR 5.5(a)(3)(i), except that full social security numbers and home addresses shall not be included on weekly transmittals. Instead the payrolls shall only need to include an individually identifying number for each employee ( e.g. , the last four digits of the employee's social security number). The required weekly payroll information may be submitted in any form desired. Optional Form WH-347 is available for this purpose from the Wage and Hour Division Web site at <http://www.dol.gov/esa/whd/forms/wh347instr.htm> or its successor site. The prime contractor is responsible for the submission of copies of payrolls by all subcontractors. Contractors and subcontractors shall maintain the full social security number and current address of each covered worker, and shall provide them upon request to the contracting agency for transmission to the State DOT, the FHWA or the Wage and Hour Division of the Department of Labor for purposes of an investigation or audit of compliance with prevailing wage requirements. It is not a violation of this section for a prime contractor to require a subcontractor to provide addresses and social security numbers to the prime contractor for its own records, without weekly submission to the contracting agency.
  - (2) Each payroll submitted shall be accompanied by a "Statement of Compliance," signed by the contractor or subcontractor or his or her agent who pays or supervises the payment of the persons employed under the contract and shall certify the following:
    - (i) That the payroll for the payroll period contains the information required to be provided under §5.5 (a)(3)(ii) of Regulations, 29 CFR part 5, the appropriate information is being maintained under §5.5 (a)(3)(i) of Regulations, 29 CFR part 5, and that such information is correct and complete;
    - (ii) That each laborer or mechanic (including each helper, apprentice, and trainee) employed on the contract during the payroll period has been paid the full weekly wages earned, without rebate, either directly or indirectly, and that no deductions have been made either directly or indirectly from the full wages earned, other than permissible deductions as set forth in Regulations, 29 CFR part 3;
    - (iii) That each laborer or mechanic has been paid not less than the applicable wage rates and fringe benefits or cash equivalents for the classification of work performed, as specified in the applicable wage determination incorporated into the contract.

- (3) The weekly submission of a properly executed certification set forth on the reverse side of Optional Form WH-347 shall satisfy the requirement for submission of the "Statement of Compliance" required by paragraph 3.b.(2) of this section.
  - (4) The falsification of any of the above certifications may subject the contractor or subcontractor to civil or criminal prosecution under section 1001 of title 18 and section 231 of title 31 of the United States Code.
  - c. The contractor or subcontractor shall make the records required under paragraph 3.a. of this section available for inspection, copying, or transcription by authorized representatives of the contracting agency, the State DOT, the FHWA, or the Department of Labor, and shall permit such representatives to interview employees during working hours on the job. If the contractor or subcontractor fails to submit the required records or to make them available, the FHWA may, after written notice to the contractor, the contracting agency or the State DOT, take such action as may be necessary to cause the suspension of any further payment, advance, or guarantee of funds. Furthermore, failure to submit the required records upon request or to make such records available may be grounds for debarment action pursuant to 29 CFR 5.12.
4. **Apprentices and trainees**
- a. Apprentices (programs of the USDOL). Apprentices will be permitted to work at less than the predetermined rate for the work they performed when they are employed pursuant to and individually registered in a bona fide apprenticeship program registered with the U.S. Department of Labor, Employment and Training Administration, Office of Apprenticeship Training, Employer and Labor Services, or with a State Apprenticeship Agency recognized by the Office, or if a person is employed in his or her first 90 days of probationary employment as an apprentice in such an apprenticeship program, who is not individually registered in the program, but who has been certified by the Office of Apprenticeship Training, Employer and Labor Services or a State Apprenticeship Agency (where appropriate) to be eligible for probationary employment as an apprentice.

The allowable ratio of apprentices to journeymen on the job site in any craft classification shall not be greater than the ratio permitted to the contractor as to the entire work force under the registered program. Any worker listed on a payroll at an apprentice wage rate, who is not registered or otherwise employed as stated above, shall be paid not less than the applicable wage rate on the wage determination for the classification of work actually performed. In addition, any apprentice performing work on the job site in excess of the ratio permitted under the registered program shall be paid not less than the applicable wage rate on the wage determination for the work actually performed. Where a contractor is performing construction on a project in a locality other than that in which its program is registered, the ratios and wage rates (expressed in percentages of the journeyman's hourly rate) specified in the contractor's or subcontractor's registered program shall be observed.

Every apprentice must be paid at not less than the rate specified in the registered program for the apprentice's level of progress, expressed as a percentage of the journeymen hourly rate specified in the applicable wage determination. Apprentices shall be paid fringe benefits in accordance with the provisions of the apprenticeship program. If the apprenticeship program does not specify fringe benefits, apprentices must be paid the full amount of fringe benefits listed on the wage determination for the applicable classification. If the Administrator determines that a different practice prevails for the applicable apprentice classification, fringes shall be paid in accordance with that determination.

In the event the Office of Apprenticeship Training, Employer and Labor Services, or a State Apprenticeship Agency recognized by the Office, withdraws approval of an apprenticeship program, the contractor will no longer be permitted to utilize apprentices at less than the applicable predetermined rate for the work performed until an acceptable program is approved.
  - b. Trainees (programs of the USDOL). Except as provided in 29 CFR 5.16, trainees will not be permitted to work at less than the predetermined rate for the work performed unless they are employed pursuant to and individually registered in a program which has received prior approval, evidenced by formal certification by the U.S. Department of Labor, Employment and Training Administration.

The ratio of trainees to journeymen on the job site shall not be greater than permitted under the plan approved by the Employment and Training Administration.

Every trainee must be paid at not less than the rate specified in the approved program for the trainee's level of progress, expressed as a percentage of the journeyman hourly rate specified in the applicable wage determination. Trainees shall be paid fringe benefits in accordance with the provisions of the trainee program. If the trainee program does not mention fringe benefits, trainees shall be paid the full amount of fringe benefits listed on the wage determination unless the Administrator of the Wage and Hour Division determines that there is an apprenticeship program associated with the corresponding journeyman wage rate on the wage determination which provides for less than full fringe benefits for apprentices. Any employee listed on the payroll at a trainee rate who is not registered and participating in a training plan approved by the Employment and Training Administration shall be paid not less than the applicable wage rate on the wage determination for the classification of work actually performed. In addition, any trainee performing work on the job site in excess of the ratio permitted under the registered program shall be paid not less than the applicable wage rate on the wage determination for the work actually performed.

In the event the Employment and Training Administration withdraws approval of a training program, the contractor will no longer be permitted to utilize trainees at less than the applicable predetermined rate for the work performed until an acceptable program is approved.
  - c. Equal employment opportunity. The utilization of apprentices, trainees and journeymen under this part shall be in conformity with the equal employment opportunity requirements of Executive Order 11246, as amended, and 29 CFR part 30.
  - d. Apprentices and Trainees (programs of the U.S. DOT). Apprentices and trainees working under apprenticeship and skill training programs which have been certified by the Secretary of Transportation as promoting EEO in connection with Federal-aid highway construction programs are not subject to the requirements of paragraph 4 of this Section IV. The straight time hourly wage rates for apprentices and trainees under such programs will be established by the particular programs. The ratio of apprentices and trainees to journeymen shall not be greater than permitted by the terms of the particular program.
5. **Compliance with Copeland Act requirements.** The contractor shall comply with the requirements of 29 CFR part 3, which are incorporated by reference in this contract.
6. **Subcontracts.** The contractor or subcontractor shall insert Form FHWA-1273 in any subcontracts and also require the subcontractors to include Form FHWA-1273 in any lower tier subcontracts. The prime contractor shall be responsible for the compliance by any subcontractor or lower tier subcontractor with all the contract clauses in 29 CFR 5.5.
7. **Contract termination:** debarment. A breach of the contract clauses in 29 CFR 5.5 may be grounds for termination of the contract, and for debarment as a contractor and a subcontractor as provided in 29 CFR 5.12.
8. **Compliance with Davis-Bacon and Related Act requirements.** All rulings and interpretations of the Davis-Bacon and Related Acts contained in 29 CFR parts 1, 3, and 5 are herein incorporated by reference in this contract.
9. **Disputes concerning labor standards.** Disputes arising out of the labor standards provisions of this contract shall not be subject to the general disputes clause of this contract. Such disputes shall be resolved in accordance with the procedures of the Department of Labor set forth in 29 CFR parts 5, 6, and 7. Disputes within the meaning of this clause include disputes between the contractor (or any of its subcontractors) and the contracting agency, the U.S. Department of Labor, or the employees or their representatives.
10. **Certification of eligibility.**
- a. By entering into this contract, the contractor certifies that neither it (nor he or she) nor any person or firm who has an interest in the contractor's firm is a person or firm ineligible to be awarded Government contracts by virtue of section 3(a) of the Davis-Bacon Act or 29 CFR 5.12(a)(1).

- b. No part of this contract shall be subcontracted to any person or firm ineligible for award of a Government contract by virtue of section 3(a) of the Davis-Bacon Act or 29 CFR 5.12(a)(1).
- c. The penalty for making false statements is prescribed in the U.S. Criminal Code, 18 U.S.C. 1001.

#### V. CONTRACT WORK HOURS AND SAFETY STANDARDS ACT

The following clauses apply to any Federal-aid construction contract in an amount in excess of \$100,000 and subject to the overtime provisions of the Contract Work Hours and Safety Standards Act. These clauses shall be inserted in addition to the clauses required by 29 CFR 5.5(a) or 29 CFR 4.6. As used in this paragraph, the terms laborers and mechanics include watchmen and guards.

1. **Overtime requirements.** No contractor or subcontractor contracting for any part of the contract work which may require or involve the employment of laborers or mechanics shall require or permit any such laborer or mechanic in any workweek in which he or she is employed on such work to work in excess of forty hours in such workweek unless such laborer or mechanic receives compensation at a rate not less than one and one-half times the basic rate of pay for all hours worked in excess of forty hours in such workweek.
2. **Violation; liability for unpaid wages; liquidated damages.** In the event of any violation of the clause set forth in paragraph (1.) of this section, the contractor and any subcontractor responsible therefor shall be liable for the unpaid wages. In addition, such contractor and subcontractor shall be liable to the United States (in the case of work done under contract for the District of Columbia or a territory, to such District or to such territory), for liquidated damages. Such liquidated damages shall be computed with respect to each individual laborer or mechanic, including watchmen and guards, employed in violation of the clause set forth in paragraph (1.) of this section, in the sum of \$10 for each calendar day on which such individual was required or permitted to work in excess of the standard workweek of forty hours without payment of the overtime wages required by the clause set forth in paragraph (1.) of this section.
3. **Withholding for unpaid wages and liquidated damages.** The FHWA or the contacting agency shall upon its own action or upon written request of an authorized representative of the Department of Labor withhold or cause to be withheld, from any moneys payable on account of work performed by the contractor or subcontractor under any such contract or any other Federal contract with the same prime contractor, or any other federally-assisted contract subject to the Contract Work Hours and Safety Standards Act, which is held by the same prime contractor, such sums as may be determined to be necessary to satisfy any liabilities of such contractor or subcontractor for unpaid wages and liquidated damages as provided in the clause set forth in paragraph (2.) of this section.
4. **Subcontracts.** The contractor or subcontractor shall insert in any subcontracts the clauses set forth in paragraph (1.) through (4.) of this section and also a clause requiring the subcontractors to include these clauses in any lower tier subcontracts. The prime contractor shall be responsible for compliance by any subcontractor or lower tier subcontractor with the clauses set forth in paragraphs (1.) through (4.) of this section.

#### VI. SUBLETTING OR ASSIGNING THE CONTRACT

This provision is applicable to all Federal-aid construction contracts on the National Highway System.

1. The contractor shall perform with its own organization contract work amounting to not less than 30 percent (or a greater percentage if specified elsewhere in the contract) of the total original contract price, excluding any specialty items designated by the contracting agency. Specialty items may be performed by subcontract and the amount of any such specialty items performed may be deducted from the total original contract price before computing the amount of work required to be performed by the contractor's own organization (23 CFR 635.116).
  - a. The term "perform work with its own organization" refers to workers employed or leased by the prime contractor, and equipment owned or rented by the prime contractor, with or without operators. Such term does not include employees or equipment of a subcontractor or lower tier subcontractor, agents of the prime contractor, or any other assignees. The term may include payments for the costs of hiring leased employees from an employee leasing firm meeting all relevant Federal and State regulatory requirements. Leased employees may only be included in this term if the prime contractor meets all of the following conditions:
    - (1) the prime contractor maintains control over the supervision of the day-to-day activities of the leased employees;
    - (2) the prime contractor remains responsible for the quality of the work of the leased employees;
    - (3) the prime contractor retains all power to accept or exclude individual employees from work on the project; and
    - (4) the prime contractor remains ultimately responsible for the payment of predetermined minimum wages, the submission of payrolls, statements of compliance and all other Federal regulatory requirements.
  - b. "Specialty Items" shall be construed to be limited to work that requires highly specialized knowledge, abilities, or equipment not ordinarily available in the type of contracting organizations qualified and expected to bid or propose on the contract as a whole and in general are to be limited to minor components of the overall contract.
2. The contract amount upon which the requirements set forth in paragraph (1) of Section VI is computed includes the cost of material and manufactured products which are to be purchased or produced by the contractor under the contract provisions.
3. The contractor shall furnish (a) a competent superintendent or supervisor who is employed by the firm, has full authority to direct performance of the work in accordance with the contract requirements, and is in charge of all construction operations (regardless of who performs the work) and (b) such other of its own organizational resources (supervision, management, and engineering services) as the contracting officer determines is necessary to assure the performance of the contract.
4. No portion of the contract shall be sublet, assigned or otherwise disposed of except with the written consent of the contracting officer, or authorized representative, and such consent when given shall not be construed to relieve the contractor of any responsibility for the fulfillment of the contract. Written consent will be given only after the contracting agency has assured that each subcontract is evidenced in writing and that it contains all pertinent provisions and requirements of the prime contract.
5. The 30% self-performance requirement of paragraph (1) is not applicable to design-build contracts; however, contracting agencies may establish their own self-performance requirements.

#### VII. SAFETY: ACCIDENT PREVENTION

This provision is applicable to all Federal-aid construction contracts and to all related subcontracts.

1. In the performance of this contract the contractor shall comply with all applicable Federal, State, and local laws governing safety, health, and sanitation (23 CFR 635). The contractor shall provide all safeguards, safety devices and protective equipment and take any other needed actions as it determines, or as the contracting officer may determine, to be reasonably necessary to protect the life and health of employees on the job and the safety of the public and to protect property in connection with the performance of the work covered by the contract.
2. It is a condition of this contract, and shall be made a condition of each subcontract, which the contractor enters into pursuant to this contract, that the contractor and any subcontractor shall not permit any employee, in performance of the contract, to work in surroundings or under conditions

which are unsanitary, hazardous or dangerous to his/her health or safety, as determined under construction safety and health standards (29 CFR 1926) promulgated by the Secretary of Labor, in accordance with Section 107 of the Contract Work Hours and Safety Standards Act (40 U.S.C. 3704).

3. Pursuant to 29 CFR 1926.3, it is a condition of this contract that the Secretary of Labor or authorized representative thereof, shall have right of entry to any site of contract performance to inspect or investigate the matter of compliance with the construction safety and health standards and to carry out the duties of the Secretary under Section 107 of the Contract Work Hours and Safety Standards Act (40 U.S.C.3704).

### VIII. FALSE STATEMENTS CONCERNING HIGHWAY PROJECTS

This provision is applicable to all Federal-aid construction contracts and to all related subcontracts.

In order to assure high quality and durable construction in conformity with approved plans and specifications and a high degree of reliability on statements and representations made by engineers, contractors, suppliers, and workers on Federal-aid highway projects, it is essential that all persons concerned with the project perform their functions as carefully, thoroughly, and honestly as possible. Willful falsification, distortion, or misrepresentation with respect to any facts related to the project is a violation of Federal law. To prevent any misunderstanding regarding the seriousness of these and similar acts, Form FHWA-1022 shall be posted on each Federal-aid highway project (23 CFR 635) in one or more places where it is readily available to all persons concerned with the project:

18 U.S.C. 1020 reads as follows:

"Whoever, being an officer, agent, or employee of the United States, or of any State or Territory, or whoever, whether a person, association, firm, or corporation, knowingly makes any false statement, false representation, or false report as to the character, quality, quantity, or cost of the material used or to be used, or the quantity or quality of the work performed or to be performed, or the cost thereof in connection with the submission of plans, maps, specifications, contracts, or costs of construction on any highway or related project submitted for approval to the Secretary of Transportation; or

Whoever knowingly makes any false statement, false representation, false report or false claim with respect to the character, quality, quantity, or cost of any work performed or to be performed, or materials furnished or to be furnished, in connection with the construction of any highway or related project approved by the Secretary of Transportation; or

Whoever knowingly makes any false statement or false representation as to material fact in any statement, certificate, or report submitted pursuant to provisions of the Federal-aid Roads Act approved July 1, 1916, (39 Stat. 355), as amended and supplemented;

Shall be fined under this title or imprisoned not more than 5 years or both."

### IX. IMPLEMENTATION OF CLEAN AIR ACT AND FEDERAL WATER POLLUTION CONTROL ACT

This provision is applicable to all Federal-aid construction contracts and to all related subcontracts.

By submission of this bid/proposal or the execution of this contract, or subcontract, as appropriate, the bidder, proposer, Federal-aid construction contractor, or subcontractor, as appropriate, will be deemed to have stipulated as follows:

1. That any person who is or will be utilized in the performance of this contract is not prohibited from receiving an award due to a violation of Section 508 of the Clean Water Act or Section 306 of the Clean Air Act.
2. That the contractor agrees to include or cause to be included the requirements of paragraph (1) of this Section X in every subcontract, and further agrees to take such action as the contracting agency may direct as a means of enforcing such requirements.

### X. CERTIFICATION REGARDING DEBARMENT, SUSPENSION, INELIGIBILITY AND VOLUNTARY EXCLUSION

This provision is applicable to all Federal-aid construction contracts, design-build contracts, subcontracts, lower-tier subcontracts, purchase orders, lease agreements, consultant contracts or any other covered transaction requiring FHWA approval or that is estimated to cost \$25,000 or more – as defined in 2 CFR Parts 180 and 1200.

#### 1. Instructions for Certification – First Tier Participants:

- a. By signing and submitting this proposal, the prospective first tier participant is providing the certification set out below.
- b. The inability of a person to provide the certification set out below will not necessarily result in denial of participation in this covered transaction. The prospective first tier participant shall submit an explanation of why it cannot provide the certification set out below. The certification or explanation will be considered in connection with the department or agency's determination whether to enter into this transaction. However, failure of the prospective first tier participant to furnish a certification or an explanation shall disqualify such a person from participation in this transaction.
- c. The certification in this clause is a material representation of fact upon which reliance was placed when the contracting agency determined to enter into this transaction. If it is later determined that the prospective participant knowingly rendered an erroneous certification, in addition to other remedies available to the Federal Government, the contracting agency may terminate this transaction for cause of default.
- d. The prospective first tier participant shall provide immediate written notice to the contracting agency to whom this proposal is submitted if any time the prospective first tier participant learns that its certification was erroneous when submitted or has become erroneous by reason of changed circumstances.
- e. The terms "covered transaction," "debarred," "suspended," "ineligible," "participant," "person," "principal," and "voluntarily excluded," as used in this clause, are defined in 2 CFR Parts 180 and 1200. "First Tier Covered Transactions" refers to any covered transaction between a grantee or subgrantee of Federal funds and a participant (such as the prime or general contract). "Lower Tier Covered Transactions" refers to any covered transaction under a First Tier Covered Transaction (such as subcontracts). "First Tier Participant" refers to the participant who has entered into a covered transaction with a grantee or subgrantee of Federal funds (such as the prime or general contractor). "Lower Tier Participant" refers any participant who has entered into a covered transaction with a First Tier Participant or other Lower Tier Participants (such as subcontractors and suppliers).
- f. The prospective first tier participant agrees by submitting this proposal that, should the proposed covered transaction be entered into, it shall not knowingly enter into any lower tier covered transaction with a person who is debarred, suspended, declared ineligible, or voluntarily excluded from participation in this covered transaction, unless authorized by the department or agency entering into this transaction.
- g. The prospective first tier participant further agrees by submitting this proposal that it will include the clause titled "Certification Regarding Debarment, Suspension, Ineligibility and Voluntary Exclusion-Lower Tier Covered Transactions," provided by the department or contracting agency, entering into this covered transaction, without modification, in all lower tier covered transactions and in all solicitations for lower tier covered transactions exceeding the \$25,000 threshold.
- h. A participant in a covered transaction may rely upon a certification of a prospective participant in a lower tier covered transaction that is not debarred, suspended, ineligible, or voluntarily excluded from the covered transaction, unless it knows that the certification is erroneous. A participant is responsible for ensuring that its principals are not suspended, debarred, or otherwise ineligible to participate in covered

transactions. To verify the eligibility of its principals, as well as the eligibility of any lower tier prospective participants, each participant may, but is not required to, check the Excluded Parties List System website (<https://www.epls.gov/>), which is compiled by the General Services Administration.

- i. Nothing contained in the foregoing shall be construed to require the establishment of a system of records in order to render in good faith the certification required by this clause. The knowledge and information of the prospective participant is not required to exceed that which is normally possessed by a prudent person in the ordinary course of business dealings.
- j. Except for transactions authorized under paragraph (f) of these instructions, if a participant in a covered transaction knowingly enters into a lower tier covered transaction with a person who is suspended, debarred, ineligible, or voluntarily excluded from participation in this transaction, in addition to other remedies available to the Federal Government, the department or agency may terminate this transaction for cause or default.

\* \* \* \* \*

**2. Certification Regarding Debarment, Suspension, Ineligibility and Voluntary Exclusion – First Tier Participants:**

- a. The prospective first tier participant certifies to the best of its knowledge and belief, that it and its principals:
  - (1) Are not presently debarred, suspended, proposed for debarment, declared ineligible, or voluntarily excluded from participating in covered transactions by any Federal department or agency;
  - (2) Have not within a three-year period preceding this proposal been convicted of or had a civil judgment rendered against them for commission of fraud or a criminal offense in connection with obtaining, attempting to obtain, or performing a public (Federal, State or local) transaction or contract under a public transaction; violation of Federal or State antitrust statutes or commission of embezzlement, theft, forgery, bribery, falsification or destruction of records, making false statements, or receiving stolen property;
  - (3) Are not presently indicted for or otherwise criminally or civilly charged by a governmental entity (Federal, State or local) with commission of any of the offenses enumerated in paragraph (a)(2) of this certification; and
  - (4) Have not within a three-year period preceding this application/proposal had one or more public transactions (Federal, State or local) terminated for cause or default.
- b. Where the prospective participant is unable to certify to any of the statements in this certification, such prospective participant shall attach an explanation to this proposal.

**2. Instructions for Certification - Lower Tier Participants:**

(Applicable to all subcontracts, purchase orders and other lower tier transactions requiring prior FHWA approval or estimated to cost \$25,000 or more - 2 CFR Parts 180 and 1200)

- a. By signing and submitting this proposal, the prospective lower tier is providing the certification set out below.
- b. The certification in this clause is a material representation of fact upon which reliance was placed when this transaction was entered into. If it is later determined that the prospective lower tier participant knowingly rendered an erroneous certification, in addition to other remedies available to the Federal Government, the department, or agency with which this transaction originated may pursue available remedies, including suspension and/or debarment.
- c. The prospective lower tier participant shall provide immediate written notice to the person to which this proposal is submitted if at any time the prospective lower tier participant learns that its certification was erroneous by reason of changed circumstances.
- d. The terms "covered transaction," "debarred," "suspended," "ineligible," "participant," "person," "principal," and "voluntarily excluded," as used in this clause, are defined in 2 CFR Parts 180 and 1200. You may contact the person to which this proposal is submitted for assistance in obtaining a copy of those regulations. "First Tier Covered Transactions" refers to any covered transaction between a grantee or subgrantee of Federal funds and a participant (such as the prime or general contract). "Lower Tier Covered Transactions" refers to any covered transaction under a First Tier Covered Transaction (such as subcontracts). "First Tier Participant" refers to the participant who has entered into a covered transaction with a grantee or subgrantee of Federal funds (such as the prime or general contractor). "Lower Tier Participant" refers any participant who has entered into a covered transaction with a First Tier Participant or other Lower Tier Participants (such as subcontractors and suppliers).
- e. The prospective lower tier participant agrees by submitting this proposal that, should the proposed covered transaction be entered into, it shall not knowingly enter into any lower tier covered transaction with a person who is debarred, suspended, declared ineligible, or voluntarily excluded from participation in this covered transaction, unless authorized by the department or agency with which this transaction originated.
- f. The prospective lower tier participant further agrees by submitting this proposal that it will include this clause titled "Certification Regarding Debarment, Suspension, Ineligibility and Voluntary Exclusion-Lower Tier Covered Transaction," without modification, in all lower tier covered transactions and in all solicitations for lower tier covered transactions exceeding the \$25,000 threshold.
- g. A participant in a covered transaction may rely upon a certification of a prospective participant in a lower tier covered transaction that is not debarred, suspended, ineligible, or voluntarily excluded from the covered transaction, unless it knows that the certification is erroneous. A participant is responsible for ensuring that its principals are not suspended, debarred, or otherwise ineligible to participate in covered transactions. To verify the eligibility of its principals, as well as the eligibility of any lower tier prospective participants, each participant may, but is not required to, check the Excluded Parties List System website (<https://www.epls.gov/>), which is compiled by the General Services Administration.
- h. Nothing contained in the foregoing shall be construed to require establishment of a system of records in order to render in good faith the certification required by this clause. The knowledge and information of participant is not required to exceed that which is normally possessed by a prudent person in the ordinary course of business dealings.
- i. Except for transactions authorized under paragraph e of these instructions, if a participant in a covered transaction knowingly enters into a lower tier covered transaction with a person who is suspended, debarred, ineligible, or voluntarily excluded from participation in this transaction, in addition to other remedies available to the Federal Government, the department or agency with which this transaction originated may pursue available remedies, including suspension and/or debarment.

\* \* \* \* \*

**Certification Regarding Debarment, Suspension, Ineligibility and Voluntary Exclusion--Lower Tier Participants:**

1. The prospective lower tier participant certifies, by submission of this proposal, that neither it nor its principals is presently debarred, suspended, proposed for debarment, declared ineligible, or voluntarily excluded from participating in covered transactions by any Federal department or agency.
2. Where the prospective lower tier participant is unable to certify to any of the statements in this certification, such prospective participant shall attach an explanation to this proposal.

\* \* \* \* \*

**XI. CERTIFICATION REGARDING USE OF CONTRACT FUNDS FOR LOBBYING**

This provision is applicable to all Federal-aid construction contracts and to all related subcontracts which exceed \$100,000 (49 CFR 20).

1. The prospective participant certifies, by signing and submitting this bid or proposal, to the best of his or her knowledge and belief, that:
  - a. No Federal appropriated funds have been paid or will be paid, by or on behalf of the undersigned, to any person for influencing or attempting to influence an officer or employee of any Federal agency, a Member of Congress, an officer or employee of Congress, or an employee of a Member of Congress in connection with the awarding of any Federal contract, the making of any Federal grant, the making of any Federal loan, the entering into of any cooperative agreement, and the extension, continuation, renewal, amendment, or modification of any Federal contract, grant, loan, or cooperative agreement.
  - b. If any funds other than Federal appropriated funds have been paid or will be paid to any person for influencing or attempting to influence an officer or employee of any Federal agency, a Member of Congress, an officer or employee of Congress, or an employee of a Member of Congress in connection with this Federal contract, grant, loan, or cooperative agreement, the undersigned shall complete and submit Standard Form-LLL, "Disclosure Form to Report Lobbying," in accordance with its instructions.
2. This certification is a material representation of fact upon which reliance was placed when this transaction was made or entered into. Submission of this certification is a prerequisite for making or entering into this transaction imposed by 31 U.S.C. 1352. Any person who fails to file the required certification shall be subject to a civil penalty of not less than \$10,000 and not more than \$100,000 for each such failure.
3. The prospective participant also agrees by submitting its bid or proposal that the participant shall require that the language of this certification be included in all lower tier subcontracts, which exceed \$100,000 and that all such recipients shall certify and disclose accordingly.



**STANDARD SPECIAL PROVISION****ON-THE-JOB TRAINING**

(10-16-07) (Rev. 4-21-15)

Z-10

**Description**

The North Carolina Department of Transportation will administer a custom version of the Federal On-the-Job Training (OJT) Program, commonly referred to as the Alternate OJT Program. All contractors (existing and newcomers) will be automatically placed in the Alternate Program. Standard OJT requirements typically associated with individual projects will no longer be applied at the project level. Instead, these requirements will be applicable on an annual basis for each contractor administered by the OJT Program Manager.

On the Job Training shall meet the requirements of 23 CFR 230.107 (b), 23 USC – Section 140, this provision and the On-the-Job Training Program Manual.

The Alternate OJT Program will allow a contractor to train employees on Federal, State and privately funded projects located in North Carolina. However, priority shall be given to training employees on NCDOT Federal-Aid funded projects.

**Minorities and Women**

Developing, training and upgrading of minorities and women toward journeyman level status is a primary objective of this special training provision. Accordingly, the Contractor shall make every effort to enroll minority and women as trainees to the extent that such persons are available within a reasonable area of recruitment. This training commitment is not intended, and shall not be used, to discriminate against any applicant for training, whether a member of a minority group or not.

**Assigning Training Goals**

The Department, through the OJT Program Manager, will assign training goals for a calendar year based on the contractors' past three years' activity and the contractors' anticipated upcoming year's activity with the Department. At the beginning of each year, all contractors eligible will be contacted by the Department to determine the number of trainees that will be assigned for the upcoming calendar year. At that time the Contractor shall enter into an agreement with the Department to provide a self-imposed on-the-job training program for the calendar year. This agreement will include a specific number of annual training goals agreed to by both parties. The number of training assignments may range from 1 to 15 per contractor per calendar year. The Contractor shall sign an agreement to fulfill their annual goal for the year.\

**Training Classifications**

The Contractor shall provide on-the-job training aimed at developing full journeyman level workers in the construction craft/operator positions. Preference shall be given to providing training in the following skilled work classifications:

Equipment Operators	Office Engineers
Truck Drivers	Estimators
Carpenters	Iron / Reinforcing Steel Workers
Concrete Finishers	Mechanics
Pipe Layers	Welders

The Department has established common training classifications and their respective training requirements that may be used by the contractors. However, the classifications established are not all-inclusive. Where the training is oriented toward construction applications, training will be allowed in lower-level management positions such as office engineers and estimators. Contractors shall submit new classifications for specific job functions that their employees are performing. The Department will review and recommend for acceptance to FHWA the new classifications proposed by contractors, if applicable. New classifications shall meet the following requirements:

Proposed training classifications are reasonable and realistic based on the job skill classification needs, and

The number of training hours specified in the training classification is consistent with common practices and provides enough time for the trainee to obtain journeyman level status.

The Contractor may allow trainees to be trained by a subcontractor provided that the Contractor retains primary responsibility for meeting the training and this provision is made applicable to the subcontract. However, only the Contractor will receive credit towards the annual goal for the trainee.

Where feasible, 25 percent of apprentices or trainees in each occupation shall be in their first year of apprenticeship or training. The number of trainees shall be distributed among the work classifications on the basis of the contractor's needs and the availability of journeymen in the various classifications within a reasonable area of recruitment.

No employee shall be employed as a trainee in any classification in which they have successfully completed a training course leading to journeyman level status or in which they have been employed as a journeyman.

**Records and Reports**

The Contractor shall maintain enrollment, monthly and completion reports documenting company compliance under these contract documents. These documents and any other information as requested shall be submitted to the OJT Program Manager.

Upon completion and graduation of the program, the Contractor shall provide each trainee with a certification Certificate showing the type and length of training satisfactorily completed.

**Trainee Interviews**

All trainees enrolled in the program will receive an initial and Trainee/Post graduate interview conducted by the OJT program staff.

**Trainee Wages**

Contractors shall compensate trainees on a graduating pay scale based upon a percentage of the prevailing minimum journeyman wages (Davis-Bacon Act). Minimum pay shall be as follows:

60 percent	of the journeyman wage for the first half of the training period
75 percent	of the journeyman wage for the third quarter of the training period
90 percent	of the journeyman wage for the last quarter of the training period

In no instance shall a trainee be paid less than the local minimum wage. The Contractor shall adhere to the minimum hourly wage rate that will satisfy both the NC Department of Labor (NCDOL) and the Department.

**Achieving or Failing to Meet Training Goals**

The Contractor will be credited for each trainee employed by him on the contract work who is currently enrolled or becomes enrolled in an approved program and who receives training for at least 50 percent of the specific program requirement. Trainees will be allowed to be transferred between projects if required by the Contractor's scheduled workload to meet training goals.

If a contractor fails to attain their training assignments for the calendar year, they may be taken off the NCDOT's Bidders List.

**Measurement and Payment**

No compensation will be made for providing required training in accordance with these contract documents.

**STANDARD SPECIAL PROVISION**

**NAME CHANGE FOR NCDENR**

(1-19-16)

Z-11

**Description**

Wherever in the 2012 Standard Specifications, Project Special Provisions, Standard Special Provisions, Permits or Plans that reference is made to “NCDENR” or “North Carolina Department of Environment and Natural Resources”, replace with “NCDEQ” or “North Carolina Department of Environmental Quality” respectively, as the case may be.

**STANDARD SPECIAL PROVISION**  
**MINIMUM WAGES**  
**GENERAL DECISION NC170101 01/06/2017 NC101**

Z-101

Date: January 6, 2017

General Decision Number: NC170101 01/06/2017 NC101

Superseded General Decision Numbers: NC20160101

State: North Carolina

Construction Type: HIGHWAY

**COUNTIES:**

Alamance	Forsyth	Randolph
Anson	Gaston	Rockingham
Cabarrus	Guilford	Stokes
Chatham	Mecklenburg	Union
Davie	Orange	Yadkin
Durham	Person	

HIGHWAY CONSTRUCTION PROJECTS (excluding tunnels, building structures in rest area projects & railroad construction; bascule, suspension & spandrel arch bridges designed for commercial navigation, bridges involving marine construction; and other major bridges).

Note: Under Executive Order (EO) 13658, an hourly minimum wage of \$10.20 for calendar year 2017 applies to all contracts subject to the Davis-Bacon Act for which the contract is awarded (and any solicitation was issued) on or after January 1, 2015. If this contract is covered by the EO, the contractor must pay all workers in any classification listed on this wage determination at least \$10.20 per hour (or the applicable wage rate listed on this wage determination, if it is higher) for all hours spent performing on the contract for calendar year 2017. The EO minimum wage rate will be adjusted annually. Additional information on contractor requirements and worker protections under the EO is available at [www.dol.gov/whd/govcontracts](http://www.dol.gov/whd/govcontracts).

Modification Number  
0

Publication Date  
01/06/2017

SUNC2014-003 11/14/2014

	Rates	Fringes
BLASTER	18.64	
CARPENTER	13.68	.05
CEMENT MASON/CONCRETE FINISHER	13.93	
ELECTRICIAN		
Electrician	18.79	2.72
Telecommunications Technician	15.19	1.25
IRONWORKER	13.30	
LABORER		
Asphalt Raker and Spreader	12.78	
Asphalt Screed/Jackman	14.50	
Carpenter Tender	12.51	.27
Cement Mason/Concrete Finisher Tender	11.04	

	Rates	Fringes
Common or General	10.40	.01
Guardrail/Fence Installer	13.22	
Pipelayer	12.43	
Traffic Signal/Lighting Installer	15.65	.24
<b>PAINTER</b>		
Bridge	23.77	
<b>POWER EQUIPMENT OPERATORS</b>		
Asphalt Broom Tractor	10.00	
Bulldozer Fine	16.13	
Bulldozer Rough	14.36	
Concrete Grinder/Groover	17.92	
Crane Boom Trucks	18.19	
Crane Other	19.83	
Crane Rough/All-Terrain	19.10	
Drill Operator Rock	14.28	
Drill Operator Structure	20.89	
Excavator Fine	16.95	
Excavator Rough	13.63	
Grader/Blade Fine	19.84	
Grader/Blade Rough	15.47	
Loader 2 Cubic Yards or Less	13.31	
Loader Greater Than 2 Cubic Yards	16.19	
Material Transfer Vehicle (Shuttle Buggy)	15.44	
Mechanic	17.51	
Milling Machine	15.22	
Off-Road Hauler/Water Tanker	11.83	
Oiler/Greaser	14.16	
Pavement Marking Equipment	12.05	
Paver Asphalt	15.97	
Paver Concrete	18.20	
Roller Asphalt Breakdown	12.79	
Roller Asphalt Finish	13.76	
Roller Other	12.08	
Scraper Finish	12.65	
Scraper Rough	11.50	
Slip Form Machine	19.60	
Tack Truck/Distributor Operator	14.82	
<b>TRUCK DRIVER</b>		
GVWR of 26,000 Lbs or Less	11.45	
GVWR of 26,000 Lbs or Greater	13.57	.03

Welders – Receive rate prescribed for craft performing operation to which welding is incidental.

Note: Executive Order (EO) 13706, Establishing Paid Sick Leave for Federal Contractors applies to all contracts subject to the Davis-Bacon Act for which the contract is awarded (and any solicitation was issued) on or after January 1, 2017. If this contract is covered by the EO, the contractor must provide employees with 1 hour of paid sick leave for every 30 hours they work, up to 56 hours of paid sick leave each year. Employees must be permitted to use paid sick leave for their own illness, injury or other health-related needs, including preventive care; to assist a family member (or person who is like family to the employee) who is ill, injured, or has other health-related needs, including preventive care; or for reasons resulting from, or to assist a family member (or person who is like family to the employee) who is a victim of, domestic violence,

sexual assault, or stalking. Additional information on contractor requirements and worker protections under the EO is available at [www.dol.gov/whd/govcontracts](http://www.dol.gov/whd/govcontracts).

Unlisted classifications needed for work not included within the scope of the classifications listed may be added after award only as provided in the labor standards contract clauses (29 CFR 5.5(a)(1)(ii)).

The body of each wage determination lists the classification and wage rates that have been found to be prevailing for the cited type(s) of construction in the area covered by the wage determination. The classifications are listed in alphabetical order of "identifiers" that indicate whether the particular rate is a union rate (current union negotiated rate for local), a survey rate (weighted average rate) or a union average rate (weighted union average rate).

#### Union Rate Identifiers

A four letter classification abbreviation identifier enclosed in dotted lines beginning with characters other than "SU" or "UAVG" denotes that the union classification and rate were prevailing for that classification in the survey. Example: PLUM0198-005 07/01/2014. PLUM is an abbreviation identifier of the union which prevailed in the survey for this classification, which in this example would be Plumbers. 0198 indicates the local union number or district council number where applicable, i.e., Plumbers Local 0198. The next number, 005 in the example, is an internal number used in processing the wage determination. 07/01/2014 is the effective date of the most current negotiated rate, which in this example is July 1, 2014.

Union prevailing wage rates are updated to reflect all rate changes in the collective bargaining agreement (CBA) governing this classification and rate.

#### Survey Rate Identifiers

Classifications listed under the "SU" identifier indicate that no one rate prevailed for this classification in the survey and the published rate is derived by computing a weighted average rate based on all the rates reported in the survey for that classification. As this weighted average rate includes all rates reported in the survey, it may include both union and non-union rates. Example: SULA2012-007 5/13/2014. SU indicates the rates are survey rates based on a weighted average calculation of rates and are not majority rates. LA indicates the State of Louisiana. 2012 is the year of survey on which these classifications and rates are based. The next number, 007 in the example, is an internal number used in producing the wage determination. 5/13/2014 indicates the survey completion date for the classifications and rates under that identifier.

Survey wage rates are not updated and remain in effect until a new survey is conducted.

#### Union Average Rate Identifiers

Classification(s) listed under the UAVG identifier indicate that no single majority rate prevailed for those classifications; however, 100% of the data reported for the classifications was union data. EXAMPLE: UAVG-OH-0010 08/29/2014. UAVG indicates that the rate is a weighted union average rate. OH indicates the state. The next number, 0010 in the example, is an internal number

used in producing the wage determination. 08/29/2014 indicates the survey completion date for the classifications and rates under that identifier.

A UAVG rate will be updated once a year, usually in January of each year, to reflect a weighted average of the current negotiated/CBA rate of the union locals from which the rate is based.

#### WAGE DETERMINATION APPEALS PROCESS

1.) Has there been an initial decision in the matter? This can be:

- \* an existing published wage determination
- \* a survey underlying a wage determination
- \* a Wage and Hour Division letter setting forth a position on a wage determination matter
- \* a conformance (additional classification and rate) ruling

On survey related matters, initial contact, including requests for summaries of surveys, should be with the Wage and Hour Regional Office for the area in which the survey was conducted because those Regional Offices have responsibility for the Davis-Bacon survey program. If the response from this initial contact is not satisfactory, then the process described in 2.) and 3.) should be followed.

With regard to any other matter not yet ripe for the formal process described here, initial contact should be with the Branch of Construction Wage Determinations. Write to:

Branch of Construction Wage Determinations  
Wage and Hour Division  
U. S. Department of Labor  
200 Constitution Avenue, N.W.  
Washington, D.C. 20210

2.) If the answer to the question in 1.) is yes, then an interested party (those affected by the action) can request review and reconsideration from the Wage and Hour Administrator (See 29 CFR Part 1.8 and 29 CFR Part 7). Write to:

Wage and Hour Administrator  
U.S. Department of Labor  
200 Constitution Avenue, N.W.  
Washington, D.C. 20210

The request should be accompanied by a full statement of the interested party's position and by any information (wage payment data, project description, area practice material, etc.) that the requestor considers relevant to the issue.

3.) If the decision of the Administrator is not favorable, an interested party may appeal directly to the Administrative Review Board (formerly the Wage Appeals Board). Write to:

Administrative Review Board  
U.S. Department of Labor  
200 Constitution Avenue, N.W.  
Washington, D.C. 20210

4.) All decisions by the Administrative Review Board are final.



PROJECT SPECIAL PROVISIONS

GEOTECHNICAL

PILES (LRFD) - (5/16/2017)

GT-1.1 - GT-1.3

DRILLED PIERS (LRFD) - (5/16/2017)

GT-2.1 - GT-2.2

GEOTEXTILE FOR PAVEMENT STABILIZATION - (1/21/2014)

GT-3.1 - GT-3.2

DocuSigned by:

*Geotechnical Engineering Unit*

E06538624A11498...

6/7/2017

**PILES****(5-16-17)**

Revise the *2012 Standard Specifications* as follows:

**Page 4-70, Article 450-2, Materials**, line 2, in the materials table, replace “Neat Cement Grout, Nonshrink” with “Neat Cement Grout, Type 1”.

**Page 4-70, Article 450-2, Materials**, line 8, in the last sentence of the second paragraph, replace “approved by the Materials and Tests Unit.” with “that are on the NCDOT Approved Products List.”

**Page 4-71, Subarticle 450-3(D), Driven Piles**, line 10, add the following after the first sentence of the third paragraph.

Use AASHTO driving stress limits for severe corrosive environments when calcium nitrite corrosion inhibitor is required for prestressed concrete piles.

**Page 4-72, Subarticle 450-3(D)(3), Required Driving Resistance**, lines 26-30, replace first paragraph with the following:

The Engineer will determine if the proposed pile driving methods and equipment are acceptable and provide the blows/ft and equivalent set for the required driving resistance noted in the plans, i.e., “pile driving criteria” except for structures with pile driving analyzer (PDA) testing. For structures with PDA testing, provide pile driving criteria for any bents and end bents with piles in accordance with Subarticle 450-3(F)(4).

**Page 4-73, Subarticle 450-3(E)(1), Pile Excavation**, lines 19-20, in the third sentence of the second paragraph, replace “use smooth or corrugated clean watertight steel casings” with “use smooth non-corrugated clean watertight steel casings”.

**Page 4-73, Subarticle 450-3(F), Pile Driving Analyzer**, lines 45-48, replace third paragraph with the following:

The Engineer will complete the review of the proposed pile driving methods and equipment within 7 days of receiving PDA reports and pile driving criteria. Do not place concrete for caps or footings on piles until PDA reports and pile driving criteria have been accepted.

**Page 4-75, Subarticle 450-3(F), Pile Driving Analyzer**, line 21, add the following to the end of Article 450-3:

(4) Pile Driving Criteria

Analyze pile driving with the GRL Wave Equation Analysis Program (GRLWEAP) manufactured by Pile Dynamics, Inc. Use the same PDA Consultant that provides PDA reports to perform GRLWEAP analyses and develop pile driving criteria. Provide driving criteria sealed by an engineer approved as a Project Engineer (key person) for the

same PDA Consultant.

Analyze pile driving so driving stresses, energy transfer, ram stroke and blows/ft from PDA testing and resistances from CAPWAP analyses correlate to GRLWEAP models. Provide pile driving criteria for each combination of required driving resistance and pile length installed for all pile types and sizes. Submit 2 copies of pile driving criteria with PDA reports. Include the following for driving criteria:

- (a) Project information in accordance with Subarticle 450-3(F)(3)(a)
- (b) Table showing blows/ft and equivalent set vs. either stroke for multiple strokes in increments of 6" or bounce chamber pressure for multiple pressures in increments of 1 psi
- (c) Maximum stroke or blows/ft or pile cushion requirements to prevent overstressing piles as needed
- (d) GRLWEAP software version information
- (e) PDF copy of all pile driving criteria and executable GRLWEAP input and output files

**Page 4-75, Article 450-4, Measurement and Payment**, line 24, add the following after the first paragraph:

*Pile Driving Equipment Setup for \_\_\_\_ Prestressed Concrete Piles, Pile Driving Equipment Setup for \_\_\_\_ Steel Piles and Pile Driving Equipment Setup for \_\_\_\_ Galvanized Steel Piles* will be measured and paid in units of each. Setting up equipment to drive piles will be measured as one per pile. No payment will be made for pile driving equipment setup for installed piles that are not driven. The contract unit price for *Pile Driving Equipment Setup for \_\_\_\_ Prestressed Concrete Piles, Pile Driving Equipment Setup for \_\_\_\_ Steel Piles and Pile Driving Equipment Setup for \_\_\_\_ Galvanized Steel Piles* will be full compensation for mobilizing and demobilizing pile driving equipment, personnel, supplies and incidentals, setting up and breaking down pile driving equipment, e.g., pile hammer, crane, template, etc. and submitting the proposed pile driving methods and equipment.

**Page 4-75, Article 450-4, Measurement and Payment**, line 31, in the fifth sentence of the second paragraph, replace "driving piles" with "furnishing and installing piles except for the items paid for separately in this article"

**Page 4-76, Article 450-4, Measurement and Payment**, lines 27-29, replace third sentence of the sixth paragraph with the following:

The contract unit price for *PDA Testing* will be full compensation for performing PDA testing the first time a pile is tested, performing CAPWAP analysis on data collected during initial drive, restrikes and redrives, providing PDA reports, performing GRLWEAP analysis and developing and providing pile driving criteria.

**Page 4-76, Article 450-4, Measurement and Payment**, line 33, add the following after the list headings:

**Pay Item**

Pile Driving Equipment Setup for \_\_\_\_ Prestressed Concrete Piles  
Pile Driving Equipment Setup for \_\_\_\_ Steel Piles  
Pile Driving Equipment Setup for \_\_\_\_ Galvanized Steel Piles

**Pay Unit**

Each  
Each  
Each

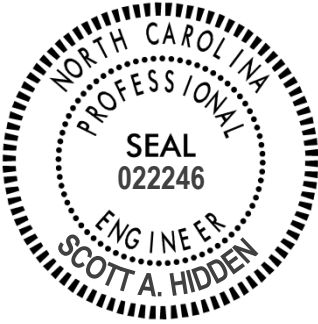

DocuSigned by:  
*Scott A. Hidden*  
F760CAEB96FC4D3...

6/7/2017

**DRILLED PIERS****(5-16-17)**

Revise the *2012 Standard Specifications* as follows:

**Page 4-9, Article 411-1, Description**, line 12, replace second sentence in the second paragraph with the following:

Define “permanent casing” as a casing that remains in the excavation and acts as a form for Drilled Pier concrete and “temporary casing” as any casing that is not permanent. Define “rock” as a continuous intact natural material with a standard penetration resistance of 0.1 ft or less per 60 blows or a rock auger penetration rate of less than 2” per 5 minutes of drilling at full crowd force or as determined by the Engineer when rock is not encountered as expected based on these criteria.

**Page 4-9, Article 411-2, Materials**, line 18, in materials table, replace “Grout, Nonshrink” with “Grout, Type 2”.

**Page 4-9, Subarticle 411-2(A), Steel Casing**, line 26, add the following after first sentence in the first paragraph:

If permanent casing is required for an excavation, the largest diameter casing in the hole is the permanent casing. This does not apply to working casings around permanent casings as approved by the Engineer.

**Page 4-10, Subarticle 411-2(B)(2), Polymer Slurry**, line 15 and **Page 4-11, Table 411-3**, replace with the following:

(2) Polymer Slurry

Use polymer slurry products qualified by the Department. Provide polymer slurry with density, viscosity, sand content and pH properties that meet the product requirements. The polymer slurry QPL with the property requirements for each qualified polymer slurry product is available from the Geotechnical Engineering Unit’s website.

**Page 4-12, Subarticle 411-3(B), Preconstruction Meeting**, line 22, replace with the following:

**(A) Preconstruction Meeting**

Before starting drilled pier construction, hold a preconstruction meeting to discuss the installation, monitoring and inspection of the drilled piers. Schedule this meeting after the Drilled Pier Contractor mobilizes to the site. If this meeting occurs before all drilled pier submittals have been accepted, additional preconstruction meetings may be required before beginning construction of drilled piers without accepted submittals. The Resident or Bridge Maintenance Engineer, Bridge Construction Engineer, Geotechnical Operations Engineer, Contractor and Drilled Pier Contractor Superintendent will attend preconstruction meetings.

**Page 4-12, Article 411-4, Construction Methods**, lines 37-39, replace with the following:

For drilled piers constructed with slurry or permanent casings, the pier diameter may be 2" less than the design pier diameter shown in the plans. For all other drilled piers, construct piers with the minimum required diameters shown in the plans except for portions of drilled piers in rock which may be 2" less than the design pier diameter.

**Page 4-13, Subarticle 411-4(A), Excavation**, line 11, add the following after second sentence in the third paragraph:

See Articles 107-11 and 107-12 for protection of public and private property and control of siltation, dust and air and water pollution from blasting, drilling and excavating with down-the-hole hammers.

**Page 4-21, Article 411-7, Measurement and Payment**, line 7-8, add “except no payment will be made for *SPT Testing* to determine if temporary casing is necessary.”



DocuSigned by:  
*Scott A. Hidden*  
F760CAEB96FC4D3...

6/7/2017

**GEOTEXTILE FOR PAVEMENT STABILIZATION:****(1-21-14)****Description**

Furnish and place geotextile for pavement stabilization in accordance with the contract. Geotextile for pavement stabilization may be required to prevent pavement cracking and provide separation between the subgrade and pavement section at locations shown in the plans and as directed.

**Materials**

Refer to Division 10 of the *Standard Specifications*.

**Item**

Geotextiles

**Section**

1056

Provide Type 5 geotextile for geotextile for pavement stabilization that meets the following requirements:

<b>GEOTEXTILE FOR PAVEMENT STABILIZATION REQUIREMENTS</b>		
<b>Property</b>	<b>Requirement (MARV<sup>A</sup>)</b>	<b>Test Method</b>
Tensile Strength @ 5% Strain (MD & CD <sup>A</sup> )	1,900 lb/ft	ASTM D4595
Ultimate Tensile Strength (MD & CD <sup>A</sup> )	4,800 lb/ft	ASTM D4595
Melting Point	300° F	ASTM D276

A. Define “minimum average roll value” (MARV), “machine direction” (MD) and “cross-machine direction” (CD) in accordance with ASTM D4439.

**Construction Methods**

Notify the Engineer when the roadbed is completed within 2" of subgrade elevation. The Engineer will sample and test subgrade soils for quality to determine if geotextile for pavement stabilization is required at locations shown in the plans and other locations as directed. For subgrades without stabilization, allow 24 days to determine if geotextile for pavement stabilization is required. For stabilized subgrades with geotextile for pavement stabilization, stabilize subgrade soils to 12" beyond the base course as shown in the plans.

Place geotextile for pavement stabilization on subgrades immediately below pavement sections as shown in the plans and in slight tension free of kinks, folds, wrinkles or creases. Install geotextiles with the MD perpendicular to the roadway centerline. The MD is the direction of the length or long dimension of the geotextile roll. Do not splice or overlap geotextiles in the MD so splices or overlaps are parallel to the roadway centerline. Extend geotextile for pavement stabilization 12" beyond the base course as shown in the plans.

Completely cover subgrades with geotextile for pavement stabilization so geotextiles are adjacent to each other in the CD, i.e., perpendicular to the MD. The CD is the direction of the width or short dimension of the geotextile roll. Overlapping geotextiles in the CD is permitted but not required. Overlap geotextiles in the direction that base course will be placed to prevent lifting the edge of the top geotextile.

For asphalt base courses, asphalt mixture temperatures in the truck may not exceed 315° F at the time of placement. Do not damage geotextile for pavement stabilization when constructing base

courses. Place and compact base courses in accordance with the *Standard Specifications*. Do not operate heavy equipment on geotextiles any more than necessary to construct pavement sections. Replace any damaged geotextiles to the satisfaction of the Engineer.

**Measurement and Payment**

*Geotextile for Pavement Stabilization* will be measured and paid in square yards. Geotextiles will be measured along subgrades as the square yards of exposed geotextiles before placing base courses. No measurement will be made for overlapping geotextiles. The contract unit price for *Geotextile for Pavement Stabilization* will be full compensation for providing, transporting and placing geotextiles.

Payment will be made under:

**Pay Item**

Geotextile for Pavement Stabilization

**Pay Unit**

Square Yard



DocuSigned by:  
*Scott A. Hidden*  
F760CAEB96FC4D3...

6/7/2017



## **OVERHEAD AND DYNAMIC MESSAGE SIGN FOUNDATIONS**

### **Description**

Sign foundations include foundations for overhead and dynamic message signs (DMS) supported by metal poles or upright trusses. Sign foundations consist of footings with pedestals or drilled piers with or without grade beams or wings, conduit and anchor rod assemblies. Construct sign foundations in accordance with the contract and accepted submittals. Define “cantilever sign” as an overhead cantilever sign support in accordance with Figure 1-1 of the *AASHTO Standard Specifications for Structural Supports for Highway Signs, Luminaires and Traffic Signals*.

### **Materials**

Use sign foundation materials that meet the *Foundations and Anchor Rod Assemblies for Metal Poles* provision.

### **Assumed Subsurface Conditions**

Assume the following soil parameters and groundwater elevation for sign foundations unless these subsurface conditions are not applicable to sign locations:

- (A) Unit weight ( $\gamma$ ) = 120 lb/cf,
- (B) Friction angle ( $\phi$ ) = 30°,
- (C) Cohesion ( $c$ ) = 0 lb/sf and
- (D) Groundwater 7 ft below finished grade.

A subsurface investigation is required if the Engineer determines these assumed subsurface conditions do not apply to a sign location and the sign cannot be moved. Subsurface conditions requiring a subsurface investigation include but are not limited to weathered or hard rock, boulders, very soft or loose soil, muck or shallow groundwater. No extension of completion date or time will be allowed for subsurface investigations.

### **Subsurface Investigations**

Use a prequalified geotechnical consultant to perform one standard penetration test (SPT) boring in accordance with ASTM D1586 at each sign location requiring a subsurface investigation. Rough grade sign locations to within 2 ft of finished grade before beginning drilling. Drill borings to 2 drilled pier diameters below anticipated pier tip elevations or refusal, whichever is higher.

Use the computer software gINT version V8i or later manufactured by Bentley Systems, Inc. with the current NCDOT gINT library and data template to produce SPT boring logs. Provide boring logs sealed by a geologist or engineer licensed in the state of North Carolina.

### **Sign Foundation Designs**

Design sign foundations for the wind zone and clearances shown in the plans and the slope of finished grade at each sign location. Use the assumed soil parameters and groundwater elevation

above for sign foundation designs unless a subsurface investigation is required. For sign locations requiring a subsurface investigation, design sign foundations for the subsurface conditions at each sign location. Design footings, pedestals, drilled piers, grade beams and wings in accordance with the 6<sup>th</sup> Edition of the *AASHTO Standard Specifications for Structural Supports for Highway Signs, Luminaires and Traffic Signals*. In some instances, conflicts with drainage structures may dictate sign foundation types.

Design footings in accordance with Section 4.4 of the *AASHTO Standard Specifications for Highway Bridges*. Do not use an allowable bearing pressure of more than 3,000 lb/sf for footings.

Design drilled piers for side resistance only in accordance with Section 4.6 of the *AASHTO Standard Specifications for Highway Bridges* except reduce ultimate side resistance by 25% for uplift. Use the computer software LPILE version 6.0 or later manufactured by Ensoft, Inc. to analyze drilled piers. Provide drilled pier designs with a horizontal deflection of less than 1" at top of piers. For cantilever signs with single drilled pier foundations supporting metal poles, use wings to resist torsion forces. Provide drilled pier designs with a factor of safety of at least 2.0 for torsion.

For drilled pier sign foundations supporting upright trusses, use dual drilled piers connected with a grade beam having a moment of inertia approximately equal to that of either pier. The Broms' method is acceptable to analyze drilled piers with grade beams instead of LPILE. Use a safety factor of at least 3.5 for the Broms' design method in accordance with C13.6.1.1 of the *AASHTO Standard Specifications for Structural Supports for Highway Signs, Luminaires and Traffic Signals*.

Submit boring logs, if any, working drawings and design calculations for acceptance in accordance with Article 105-2 of the *2012 Standard Specifications*. Submit working drawings showing plan views, required foundation dimensions and elevations and typical sections with reinforcement, conduit and anchor rod assembly details. Include all boring logs, design calculations and LPILE output for sign foundation design submittals. Have sign foundations designed, detailed and sealed by an engineer licensed in the state of North Carolina.

### **Construction Methods**

Construct footings, pedestals, drilled piers, grade beams and wings and install anchor rod assemblies for sign foundations in accordance with the *Foundations and Anchor Rod Assemblies for Metal Poles* provision.

### **Measurement and Payment**

*Overhead Footings* will be measured and paid in cubic yards. Sign foundations will be measured as the cubic yards of foundation concrete for footings, pedestals, drilled piers, grade beams and wings shown on the accepted submittals. The contract unit price for *Overhead Footings* will be full compensation for providing labor, tools, equipment and foundation materials, stabilizing or shoring excavations and supplying concrete, reinforcing steel, conduit, anchor rod assemblies and any incidentals necessary to construct sign foundations. Subsurface investigations required by the Engineer will be paid as extra work in accordance with Article 104-7 of the *2012 Standard Specifications*.

Payment will be made under:

**Pay Item**

Overhead Footings

**Pay Unit**

Cubic Yard



DocuSigned by:

*Scott A. Hidden*

F760CAEB96FC4D3...

5/31/2017



DocuSigned by:  
*Renee Roach*  
 B3C6C6F7CF4640D...  
 5/31/2017 | 2:04 PM EDT

**OVERHEAD SIGN SUPPORTS**

**DESCRIPTION**

Design, fabricate, furnish and erect various types of overhead sign assemblies. Fabricate supporting structures using tubular members of either aluminum or steel. The types of overhead sign assemblies included in this specification are span structures, cantilever structures and sign structures attached to bridges.

**Materials**

Refer to Division 10

<b>Item</b>	<b>Section</b>
Structural Steel	1072
Overhead Sign Structures	1096
Signing Materials	1092
Organic Zinc Repair Paint	1080-9
Reinforcing Steel	1070
Direct Tension Indicators	440 and 1072

**Construction Methods**

**A. General**

Fabricate overhead sign assemblies in accordance with the details shown in the approved working drawings and the requirements of these specifications.

No welding, cutting or drilling will be permitted in the field, unless approved by the Engineer.

Drill bolt holes and slots to finished size. Holes may also be punched to finish size, provided the diameter of the punched holes is at least twice the thickness of the metal being punched. Flame cutting of bolt holes and slots is not permitted.

Erect sign panels in accordance with the requirement for Type A or B signs as indicated in the plans or Roadway Standard Drawings. Field drill two holes per connection in the Z bars for attaching signs to overhead structures. Provide two U-bolts at each U-bolt connection such as each truss chord to sign hanger and each truss chord to walkway support or light support.

Provide two U-bolts at each U-bolt connection where ends of truss chords are supported. The minimum diameter of all U-bolts is ½ inch.

For all U-bolt connections of hanger beams to overhead assembly truss chords, provide all U-bolts with a flat washer and double nuts at each end of the U-bolts. All double nuts that are on any U-bolt shall be the same thickness and weight. When assembled, the double nuts shall be brought tight against each other by the use of two wrenches.

Use two coats of a zinc-rich paint to touch up minor scars on all galvanized materials

For high strength bolted connections, use direct tension indicators. Galvanize bolts, nuts and washers in accordance with the Standard Specifications.

### **B. Shop Drawings**

Design the overhead sign supports, including foundations, prior to fabrication. Submit design calculations and working drawings of the designs to the Engineer for review and acceptance.

Have a professional engineer registered in the State of North Carolina perform the computations and render a set of sealed, signed and dated drawings detailing the construction of each structure.

Submit to the Engineer for review and acceptance complete design and fabrication details for each overhead sign assembly, including foundations and brackets for supporting the signs and maintenance walkways, if applicable, electrical control boxes, and lighting luminaires. Base design upon the revised structure line drawings, wind load area and the winds speed shown in the plans, and in accordance with the AASHTO *Standard Specifications for Structural Structures for Highway Signs, Luminaires and Traffic Signals, 6<sup>th</sup> Edition, 2013 and 2015 Interim Revisions*.

Submit electronic (.pdf) copies of completely detailed working drawings and the design calculations including all design assumptions for each overhead sign assembly to the Engineer for approval prior to fabrication. Working drawings shall include complete design and fabrication details (including foundations), provisions for attaching signs, maintenance walkways (when applicable), lighting luminaires to supporting structures, applicable material specifications, and any other information necessary for procuring and replacing any part of the complete overhead sign assembly.

Allow 40 days for initial working drawing review after the Engineer receives them. If revisions to working drawings are required, an additional 40 days shall be required for review and approval of the final working drawings.

Approval of working drawings by the Engineer shall not relieve the Contractor of responsibility for the correctness of the drawings, or for the fit of all shop and field connections and anchors.

**C. Design and Fabrication**

The following criteria govern the design of overhead sign assemblies:

Design shall be in accordance with the AASHTO *Standard Specifications for Structural Structures for Highway Signs, Luminaires and Traffic Signals, 6<sup>th</sup> Edition, 2013 and 2015 Interim Revisions.*

Within this Specification, there are several design criteria that are owner specified. They include:

- Overhead cantilever sign structures shall include galloping loads (exclude four-chord horizontal trusses)
- The Yearly Mean Wind Velocity,  $V_{\text{mean}}$ , in North Carolina shall be assumed to be 11.6 mph.
- The Fatigue Importance Category used in the design, for each type of structure, shall be for:
  - Cantilevered structures with span greater than 50 feet – Fatigue Importance Category I.
  - Cantilevered structures with span less than or equal to 50 feet – Fatigue Importance Category II.
  - Non-Cantilevered structures – Fatigue Importance Category II.

The following Specification interpretations or criteria shall be used in the design of overhead sign assemblies:

- For design of supporting upright posts or columns, the effective length factor for columns “K”, as provided for in Appendix B, Section B.5, shall be taken as the following, unless otherwise approved by the Engineer:
  - Case 1 For a single upright post of cantilever or span type overhead sign structure, the effective column length factor, “K”, shall be taken as 2.0.
  - Case 2 For twin post truss-type upright post with the post connected to one chord of a horizontal truss, the effective column length factor for that column shall be taken as 2.0.
  - Case 3 For twin post truss-type upright post with the post connected to two truss chords of a horizontal tri-chord or box truss, the effective column length factor for that column shall be taken as 1.65.
- For twin post truss-type uprights, the unbraced length of the post shall be from the chord to post connection to the top of base plate.

- For twin post truss-type uprights, when the post is subject to axial compression, bending moment, shear, and torsion, the post shall satisfy the AASHTO Standard Specifications for Structural Structures for Highway Signs, Luminaires and Traffic Signals, 6<sup>th</sup> Edition, 2013 and 2015 Interim Revisions Equations 5.12.2.1-1, 5.12.2.1-2 and 5.12.2.1-5. To reduce the effects of secondary bending, in lieu of Equation 5.12.2.1-2, the following equation may be used:

$$\frac{f_a}{F_a} + \frac{f_b}{\left(1 - \frac{0.6f_a}{F_e}\right) F_b} + \left(\frac{f_v}{F_v}\right)^2 \leq 1.0$$

Where  $f_a$  = Computed axial compression stress at base of post

- The base plate thickness for all uprights and poles shall be a minimum of 2" but not less than that determined by the following criteria and design.

Case 1 Circular or rectangular solid base plates with the upright pole welded to the top surface of the base plate with full penetration butt weld, and where no stiffeners are provided. A base plate with a small center hole, which is less than 1/5 of the upright diameter, and located concentrically with the upright pole, may be considered as a solid base plate.

The magnitude of bending moment in the base plate, induced by the anchoring force of each anchor bolt shall be calculated as  $M = (P \times D_1) / 2$ .

Case 2 Circular or rectangular base plate with the upright pole socketed into and attached to the base plate with two lines of fillet weld, and where no stiffeners are provided, or any base plate with a center hole that is larger in diameter than 1/5 of the upright diameter. The magnitude of bending moment induced by the anchoring force of each anchor bolt shall be calculated as  $M = P \times D_2$ .

Where:

- M = bending moment at the critical section of the base plate induced by one anchor bolt
- P = anchoring force of each bolt
- D<sub>1</sub> = horizontal distance between the center of the anchor bolt and the outer face of the upright, or the difference between the radius of the bolt circle and the radius of the upright
- D<sub>2</sub> = horizontal distance between the face of the upright and the face of the anchor bolt nut

- The critical section shall be located at the face of the anchor bolt and perpendicular to the radius of the bolt circle. The overlapped part of two adjacent critical sections shall be considered ineffective.

- The thickness of Case 1 base plate shall not be less than the calculated based on formula for Case 2.
- Uprights, foundations, and trusses that support overhead signs shall be designed in accordance with the Overhead and Dynamic Message Sign Foundations Project Special Provision for the effects of torsion. Torsion shall be considered from dead load eccentricity of these attachments, as well as for the attachments such as supporting brackets, lights, etc., that add to the torsion in the assembly. Truss vertical and horizontal truss diagonals in particular and any other assembly members shall be appropriately sized for these loads
- Uprights, foundations, and trusses that support overhead mounted signs shall be designed for the proposed sign wind area as noted in the contract drawings. Truss vertical and horizontal truss diagonals in particular and any other assembly members shall be appropriately sized for these loads.

For non-cantilevered monotube sign support structures, the following table and figures are considered as a required addition to the AASHTO *Standard Specifications for Structural Structures for Highway Signs, Luminaires and Traffic Signals, 6<sup>th</sup> Edition, 2013 and 2015 Interim Revisions*:

Construction	Detail	Stress Category	Application	Example
Mechanically Fastened Connections	25. Bolts in tension	D	Beam column connection for monotube structures	16
Fillet-Welded Connections	26. Fillet weld with one side normal to the applied stress	E'	Beam column connection for monotube structures	16
Mechanically Fastened Connections	27. High-Strength bolts in tension	D	Monotube or truss-chord splice	17
Fillet-Welded Connections	28. Fillet weld with one side normal to the applied stress	E'	Monotube or truss-chord splice	17
Mechanically Fastened Connections	29. U-bolts tied to the transverse truss column to keep the chords in place	D	Horizontal truss connection with the vertical truss	18
Mechanically Fastened Connections	30. Net section of full-tightened, high-tension bolts in shear	B	Truss-bolted joint	18



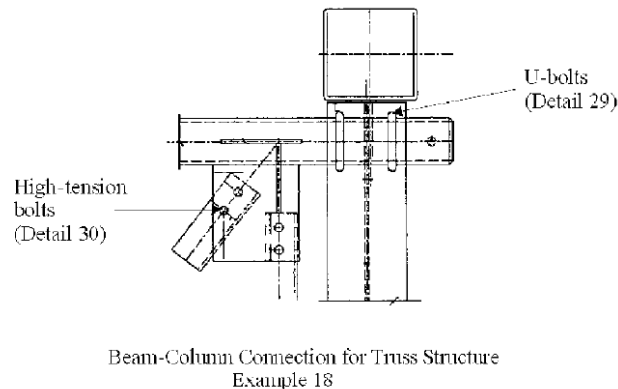
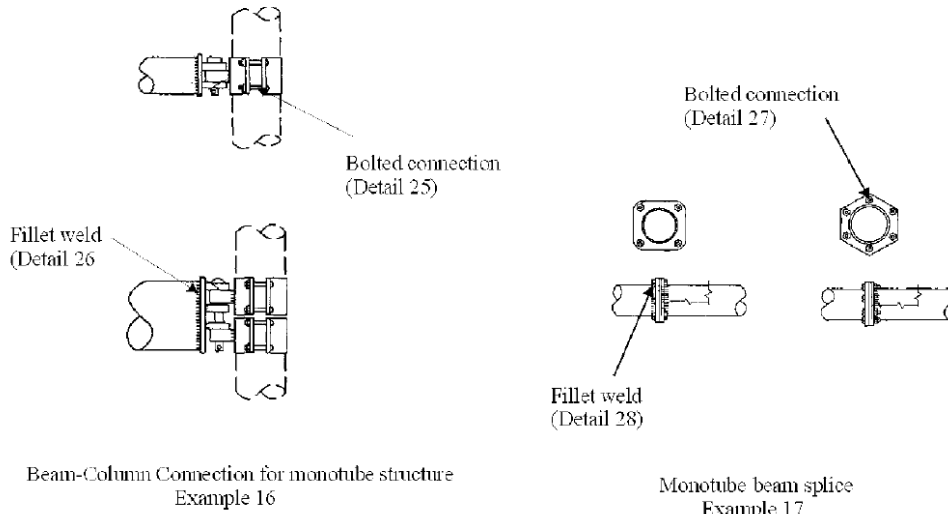

\* From NCHRP Report 494 dated 2003

Fabricate all overhead sign assemblies, including but not limited to foundations, in accordance with the details shown on the approved shop drawings and with the requirements of these Specifications.

Fabricate the span and cantilever supporting structures using tubular members of either aluminum or steel, using only one type of material throughout the project. Sign support structures that are to be attached to bridges shall be fabricated using other structural shapes.

Horizontal components of the supporting structures for overhead signs may be of a truss design or a design using singular (monotube) horizontal members to support the sign panels.

Truss or singular member centerline must coincide with the centerline of sign design area shown on the structure line drawing.

Provide permanent camber in addition to dead load camber in accordance with the AASHTO *Standard Specifications for Structural Structures for Highway Signs, Luminaires and Traffic Signals, 6<sup>th</sup> Edition, 2013 and 2015 Interim Revisions*. Indicate on the shop drawings the amount

of camber provided and the method employed in the fabrication of the support to obtain the camber.

Use cantilever sign structures that meet the following design criteria:

- a. Do not exceed an L/150 vertical dead load deflection at the end of the arm due to distortions in the arm and vertical support, where L is the length of the arm from the center of the vertical support to the outer edge of the sign.
- b. Do not exceed an L/40 horizontal deflection at the end of the arm due to distortions in the arm and vertical support, as a result of design wind load.

Fabricate attachment assemblies for mounting signs in a manner that allows easy removal of sign panels for repair.

**D. Compensation**

The work covered by this section will be paid for at the contract lump sum for each *Supports, Overhead Sign Structure @ \_\_\_\_\_*. Such price will be full compensation for all work covered by this specification includes all design, fabrication, construction, transportation, and erection of the complete overhead sign structure, supporting structure, hardware, lighting support brackets, preparing and furnishing shop drawings, and attaching the signs to the overhead assembly.

Payment will be made under:

Supports, Overhead Sign Structure @ _____	Lump Sum
-------------------------------------------	----------

# TC-1

U-2579C

Forsyth County

## **TRAFFIC CONTROL DEVICES TO REMAIN ON PROJECT:**

(02/05/2013)

### **Description**

Furnish, install, maintain during the life of the project, and leave Traffic Control Devices on the project at its completion in accordance with the plans and specifications.

### **Construction Methods**

Install and leave on the project the Traffic Control Devices necessary to accommodate the traffic pattern shown on sheet **TMP-20** of the Transportation Management Plan, unless otherwise directed by the Engineer.

Provide devices to remain on the project, which meet the requirements of their respective specifications in the 2012 Standard Specifications or their respective special provisions.

Provide devices to remain on the project that are in good condition and subject to the approval of the Engineer.

The devices required to remain on the project at its completion will become the property of the Department.

### **Basis Of Payment**

No additional payment will be made specifically for leaving devices on the project. These devices will be paid under their respective pay items in the Contract which will include full compensation for furnishing, installing, maintaining during the life of the project, and leaving the devices on the project at its completion.



DocuSigned by:

*Michael T. Rzepka*

01BC3480C26049D...

6/2/2017

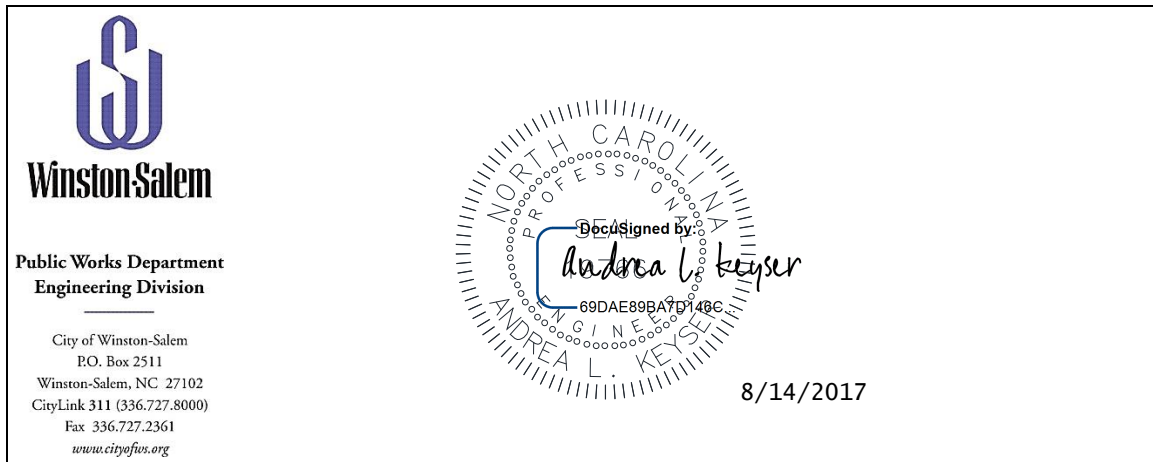

**Revise the 2012 Standard Specifications as follows:**

**Page 10-58, Article 1036-1 General**

add the following sentence:

All materials in contact with potable water shall be in conformance with Section 1417 of the Safe Drinking Water Act.

**Page 10-58, Article 1036-5 Ductile Iron Pipe and Fittings:**

replace with the following:

Ductile iron pipe shall be designed to conform to ANSI A21.50 (AWWA C150) and shall be manufactured to conform to ANSI A21.51 (AWWA C151). The interior of pipe for water will be cement lined in accordance with ANSI A21.4 (AWWA C104). The interior of pipe for sanitary sewer will be lined with 40 mils of Protecto 401 Ceramic Epoxy. All bells and spigots for sanitary sewer pipe must be lined with a minimum of 8 mils of Protecto 401 Joint Compound or approved equal. The exterior of all pipe shall be coated with a bituminous coating. Pipe joints will be single rubber gasket push-on type or mechanical joint type unless otherwise specified or otherwise shown on the Engineer's drawings. Rubber gasket joints shall conform to ANSI A21.11 (AWWA C111). Pipe design laying condition will be Type 2, flat-bottom trench with backfill lightly consolidated to centerline of pipe. Pipe for sanitary sewer shall be minimum thickness Class 50. Pipe for water shall be pressure Class 350 for 3" - 16" and pressure Class 250 for 18" and above. Any deviations in class shall be otherwise specified or otherwise shown on the Engineer's drawings. If for any reason the Engineer finds any or all ductile iron pipe unacceptable, the Contractor shall be responsible for obtaining acceptable pipe. The Engineer's acceptance or rejection of all pipe will be final.

All restrained joint pipe and fittings shall have flexible push-on joints unless otherwise approved by the Engineer. At locations where field cutting of restrained joint pipe is required for fittings, the TR Flex Gripper Ring may be used. Field welding will not be allowed. Restrained joint pipe and fittings with a gripping gasket as the only means of restraint will not be allowed. Pipe and fittings shall be Flex-Ring by American, TR Flex by U.S. Pipe, or TR Flex by McWane. If for any reason the Engineer finds any or all ductile iron flexible restrained joint pipe unacceptable, the Contractor shall be responsible for obtaining acceptable pipe. The Engineer's acceptance or rejection of all pipe will be final.

Ductile iron fittings shall meet all requirements of ANSI A21.10 (AWWA C110) and will be of the mechanical joint type unless otherwise specified. All glands shall be ductile iron, not gray iron. The interior of fittings for water will be cement lined in accordance with ANSI A21.4 (AWWA C104). The interior of fittings for sanitary sewer will be lined with 40 mils of Protecto 401 Ceramic Epoxy. All bells and spigots for sanitary sewer fittings must be lined with a minimum of 8 mils of Protecto 401 Joint Compound or approved equal. The exterior of all fittings shall be coated with a bituminous coating. Fittings coated on the interior and exterior with 8 mils of fusion bonded epoxy in accordance with ANSI/AWWA C116 and ANSI/AWWA C550 are acceptable. Fittings will have a minimum pressure rating of 250 psi unless otherwise specified by the Engineer. Rubber gasket joints shall conform to ANSI A21.11 (AWWA C111). Ductile iron compact fittings conforming to ANSI A21.53 (AWWA C153) are acceptable. "DI" or "Ductile" shall be cast on each fitting. All Fittings are subject to approval by the Engineer, and their acceptance or rejection shall be final.

**Page 10-59, Article 1036-6 Fire Hydrants:**

add the following:

Hydrants accepted by the City of Winston-Salem are as follows (or approved equal):

- (1) Super Centurion 250, manufactured by Mueller Company
- (2) MK-73-5, manufactured by American Flow Control
- (3) K-81D Guardian, manufactured by Kennedy Valve Company
- (4) Medallion, manufactured by Clow Valve Company

**Page 10-59, Sub-article 1036-7 (A) Gate Valves:**

replace with the following:

All gate valves shall be resilient-seated gate valves which meet the specifications of ANSI/AWWA C509 or ANSI/AWWA C515. The valve body, bonnet and seal plate shall be coated on all exterior and interior surfaces with a minimum of 8-10 mils of fusion bonded epoxy in accordance with ANSI/AWWA C550. The valve shall incorporate a

guide system with guide lugs on the wedge or on the body. The wedge shall be gray or ductile iron, fully encapsulated with rubber (including guide lugs and stem nut holder). Non-rising stem valves shall have two O-ring seals above the stem thrust collar that can be replaced with the valve under pressure. Non-rising stem valves shall also have a thrust washer on the stem thrust collar. Valves used for buried service will have a non-rising stem, mechanical joint end connections, and a 2" square operating nut. The word "OPEN" and an arrow to indicate the direction of opening the valve shall be cast on the flanged base of the operating nut. Above ground valves, unless otherwise specified, will have an outside screw and yoke rising stem or a non-rising stem, flanged end connections, and a handwheel to operate the valve. The word "OPEN" and an arrow to indicate the direction of opening the valve shall be cast on the rim of the handwheel. All valves will open by turning the nut or handwheel counterclockwise. Valves installed in manholes will normally be considered to be buried service valves and valves installed in vaults will normally be considered to be above ground valves.

Resilient-seated gate valves shall be designed for a minimum working pressure of 250 psi. Each valve shall be seat tested at the rated working pressure and shell tested at twice the rated working pressure in accordance with ANSI/AWWA C509 - Section 5 or ANSI/AWWA C515 - Section 5. All valves shall be warranted for 10 years from date of purchase against defective materials and workmanship. Gate valves furnished under these specifications must be manufactured by one of the following or approved equal:

- (1) Clow Valve Company
- (2) M & H Valve Company
- (3) American Flow Control
- (4) U.S. Pipe and Foundry Company
- (5) Mueller Company
- (6) Kennedy Valve Company

**Page 10-59, Sub-article 1036-7 (B) Bronze Gate Valves:**  
replace with the following:

The use of bronze gate valves shall not be permitted.

**Page 10-59, Sub-article 1036-7 (C) Tapping Valves:**  
replace with the following:

Use tapping valves conforming to Sub-article 1036-7 (A). The valve shall have an inlet flange (with centering ring) for connection to the flanged sleeve outlet.

Tapping valves furnished under these specifications must be manufactured by one of the following or approved equal:

- (1) Clow Valve Company
- (2) M & H Valve Company
- (3) American Flow Control
- (4) U.S. Pipe and Foundry Company
- (5) Mueller Company
- (6) Kennedy Valve Company

**Page 10-59, Sub-article 1036-8 (A) Tapping Sleeves:**

replace with the following:

Tapping sleeves shall be a split sleeve with mechanical joint end connections and a flanged outlet. Sleeves shall be designed for a minimum working pressure of 200 psi.

Approved tapping sleeves are as follows (or approved equal):

- (1) Mueller Company
- (2) American Flow Control
- (3) Tyler Pipe Company
- (4) U.S. Pipe and Foundry Company
- (5) Kennedy Valve Company

**Page 10-59, Article 1036-8 Sleeves, Couplings and Miscellaneous:**

add the following:

**(C) Valve Boxes**

Cast iron valve boxes will conform to ASTM A48, Class 30B. All boxes will conform to the shape and dimensions shown on the City of Winston-Salem detail drawings and will be free from holes, cracks or any other defects. All castings will be thoroughly coated with an asphaltic varnish. The name of the manufacturer shall be permanently cast on each piece. Valve boxes that do not meet specifications shall be rejected. Cast iron valve boxes furnished under these specifications shall be manufactured by one of the following or approved equal:

- (1) Sigma Corp.
- (2) SIP Industries
- (3) DSI International
- (4) Star Pipe Products

**Page 10-59, Article 1036-8 Sleeves, Couplings and Miscellaneous:**  
add the following:

**(D) Check Valves**

Check valves for use in Blow-Off Assemblies shall be Series 35 flanged check valves by Red Valve Company with stainless steel backup rings or approved equal.

**Page 10-58, Article 1036 Water Pipe and Fittings:**  
add the following:

**1036-10 Casing Spacers**

Casing spacers shall be made of Type 304 stainless steel (including risers and hardware). Each shell shall be PVC lined and shall have bolted flanges. Casing spacer runners shall be constructed of ultra high molecular weight polymer (minimum 1 ½" wide) with a friction coefficient of not more than .12. Risers shall be 10 gauge. Risers and runners for top and bottom shells shall be of equal height. With approval of the Engineer, unequal height risers and runners may be used to obtain proper grade for sanitary sewer mains. Casing spacers must be designed to ensure that only the runners of the spacer are in contact with the steel encasement pipe. The bell of the carrier pipe will not be allowed to be in contact with the encasement. Casing spacers shall be manufactured by one of the following or approved equal:

- (1) Cascade Waterworks Manufacturing Company
- (2) Advance Products and Systems, Inc.
- (3) BWM Company
- (4) Black Widow by Spider Manufacturing, Inc.

**1036-11 Retainer Glands**

All retainer glands shall be wedge action glands with torque limiting twist off nuts. Glands shall be Megalug Series 1100 by EBAA Iron, Inc., Uni- Flange Series 1400 by Ford Meter Box Company, Inc., RomaGrip by Romac Industries, Inc., One-Lok Series SLDE by Sigma Corp., Stargrip Series 3000 by Star Pipe Products, Cam-Lock Series 111 by Smith-Blair, Inc., EZ Grip by SIP Industries, Tufgrip by Tyler Union, or approved equal.

**Page 15-1, Article 1500-2 Cooperation with the Utility Owner, paragraph 2:**  
add the following sentences:

The utility owner is the Winston-Salem/Forsyth County Utilities Commission. The contact person is David Doss and he can be reached by phone at (336) 727-8063.



The materials and appurtenances installed by the contractor shall require approval by both NCDOT and the utility owner prior to installation.

**Page 15-4, Sub-article 1505-3 (E), Thrust Restraint:**

replace the fourth paragraph with the following:

Concrete thrust blocks shall be constructed as directed by the Engineer at all bends, tees, tapping sleeves, tapping saddles, reducers, plugs, etc. to provide restraint against thrust resulting from internal pressure. Any exceptions to this such as restrained joints or mechanical joints with retainer glands will be noted on the Engineer's drawings or otherwise specified. Thrust blocks will not be required for restrained joint pipe (exception - blocking will be required when connecting restrained pipe to existing pipe).

All thrust blocks will be constructed of a minimum of Class A concrete. Thrust blocks for bends, fire hydrants, tees and stub-outs shall be constructed in accordance with the City of Winston-Salem thrust block detail drawings.

Polyethylene shall be placed over all fittings before the concrete is poured. All nuts and bolts shall be clear of concrete so that the joint will be accessible. Plywood shall be used as forms for blocking. Concrete is to be poured only against stable undisturbed soil and should be allowed to set prior to any backfilling. Thrust blocks should be allowed to cure two days prior to pressure testing the water main. Higher strength concrete may be required when it is necessary to pressure test prior to the end of the two day curing time.

**Page 15-6, Sub-article 1510-3 (B), Testing and Sterilization:**

add the following:

All tapping sleeves and valves shall be water tested before the tap is made. Test pressure shall be 200 psi for 15 minutes without any drop in pressure.

change the allowable leakage formula to:

$$W = LD\sqrt{P} \div 148,000$$

**Page 15-6, Sub-article 1510-3 (B), Testing and Sterilization, sixth paragraph:**

Replace the paragraph with the following:

Sterilize water lines in accordance with Section 1003 of The Rules Governing Public Water supply and AWWA C651 Section 4.4.3, the Continuous Feed Method. Provide a chlorine solution with between 50 parts per million and 100 parts per million in the initial feed. If the chlorine level drops below 10 parts per million during a 24 hour period, then

flush, refill with fresh chlorine solution, and repeat for 24 hours. Provide certified bacteriological and contaminant test results from a state-approved or state-certified laboratory. Operate all valves and controls to assure thorough sterilization.

**Page 15-6, Sub-article 1510-3 (B), Testing and Sterilization, seventh paragraph:**

delete the words “may be performed concurrently or consecutively.” and replace with “shall be performed consecutively.”

**Page 15-7, Article 1510-4 Measurement and Payment:**

add the following paragraph after line 7:

The quantity of *Ductile Iron Water Pipe Fittings* will be measured and paid per pound based on the published weights for ductile iron fittings, exclusive of the weights of any accessories, as listed in the “DI Fittings Weight Chart” located at <https://connect.ncdot.gov/municipalities/Utilities/Pages/Estimates-Materials.aspx>. If the Contractor elects to use compact ductile iron water pipe fittings, measurement will be based on the weight of standard size ductile iron water pipe fittings. Any fitting not listed will be measured based on the published weights for ductile iron fittings listed in ANSI/AWWA C-110/A21.10. This is limited to pressure pipe 4 inches or larger.

**Page 15-7, Article 1510-4 Measurement and Payment:**

add the following pay item:

<b>Pay Item</b>	<b>Pay Unit</b>
Ductile Iron Water Pipe Fittings	Pound

**Page 15-7, Article 1515-2 Materials, line 19:**

replace the first sentence with the following:

Air release valves shall meet ANSI/AWWA C512. The air release valve shall be a Type 316 stainless steel (all parts). The pressure air valve shall have an operating pressure of 0-200 psi. The bronze ball valve curb stops shall have a minimum working pressure of 200 psi.

**Page 15-7, Article 1515-3 Construction Methods:**

add the following:

**(H) Tapping Sleeves**

Tapping sleeves and valves shall be used for "wet" taps into existing water mains as indicated on the Engineer's drawings. The Contractor shall verify the type of material, size, etc., of the existing main prior to ordering the sleeve. For taps on larger mains (24" and above), a saddle may be used in lieu of a sleeve, but only if the tap is less than or equal to half the size of the line to be tapped. All tapping sleeves and valves shall be water tested before the tap is made. Test pressure shall be 200 psi for 15 minutes without any drop in pressure. All tapping sleeves and valves shall be installed level. The Engineer must be present during the entire tapping and testing process.

**Page 15-8, Sub-article 1515-3 (B), Meters:**

add the following:

For relocated water meters the Contractor shall install a new meter box, angle valves, yoke, tee and ball valve as directed by the Engineer. The Contractor shall expose a portion of the water line from the dwelling or business to determine the material and have proper fittings for reconnection to the new meter box. At the approval of the Engineer, the Contractor shall remove the existing meter and install it in the new yoke. The Contractor shall reconnect the property side water line from the existing meter box to the new meter box. This reconnection shall be directed by the Engineer and performed in a timely manner so that the property is without water for a minimal amount of time. The Contractor shall remove and dispose of the existing meter box and yoke and backfill as shown on the plans or as directed by the Engineer.

**Page 15-8, Sub-article 1515-3 (F), Air Release Valves:**

add the following to line 43:

Air release valves will be installed as per the City of Winston-Salem detail drawings for "Air Release Valves".

**Page 15-9, Article 1515-4 Measurement and Payment, line 28:**

delete "fittings".

**Page 15-9, Article 1515-4 Measurement and Payment:**

add the following:

Air Release Valves shall be paid per each for the appropriate size and shall include furnishing and installing a corporation cock on the main, two bronze ball valve curb stops, brass pipe, brass fittings, air release valve, and manhole as indicated on City of Winston-Salem detail drawings for "Air Release Valve".

Blow-Offs will be measured and paid per each for the appropriate size and shall include installation of everything shown on the detail drawing for “Blow-Off Assembly”.

For new and relocated ¾” & 1” water connections, the Contractor shall install connection per the City of Winston-Salem detail drawing for “¾” & 1” Water Connection (Without Curb & Gutter / Single Family)”.

**Page 15-13, Article 1525-2, Materials, lines 15-19:**

replace with the following:

Manhole rings and covers will be made of cast iron and will conform to ASTM A48, Class 35B. In addition, all manhole rings and covers shall be designed to support an H-20 wheel load. All castings will conform to the shape and dimensions shown on the City of Winston-Salem detail drawing and will be free from holes, cracks or any other defects. Rings and covers will have machined seats so that the cover will not rattle. Rings will weigh a minimum of 190 pounds and covers a minimum of 120 pounds. The name of the manufacturer and the part number shall be cast permanently on the ring and the cover. Castings that do not meet specifications shall be rejected.

**Page 15-15, Article 1530-3 Construction Methods:**

add the following:

**(E) Abandoning Sewer Connections**

Sewer connections shall be abandoned by removing the cleanout stack (if one exists) and plugging the lateral at the base of the stack. If no cleanout exists, the Contractor shall plug the lateral at the right-of-way line.

**Page 15-15, Sub-article 1530-3 (A), Abandoning Pipe:**

add the following paragraph:

When abandoning water mains up to a main that is to remain in service, any valve or tee associated with the main to be abandoned shall be removed. A sleeve and any necessary piping shall be installed to reconnect the water main to remain in service. All other main line valves on abandoned water mains shall be abandoned by removing the valve box. The work covered in this paragraph shall be considered incidental to the abandonment.

**Page 15-16, Sub-article 1530-3 (C), Remove Water Meter:**

replace the first sentence with the following:

Remove water meter by closing the corporation cock at the main and removing the lateral including the angle valve, setter and meter box.

**Page 15-16, Article 1530-4 Measurement and Payment:**

add the following pay item:

<b>Pay Item</b>	<b>Pay Unit</b>
Abandon Sewer Connection	Each

**Page 15-17, Sub-article 1540-3 (D), Carrier Pipe Installation, lines 20-22:**

replace with the following:

Carrier pipe installed through encasement shall be ductile iron flexible restrained joint pipe. Casing spacers are required and shall be placed at 10 foot intervals within the encasement. One spacer shall be placed not more than 2 feet from each end of the encasement. Only the runners of the casing spacer shall be in contact with the encasement. The bell of the carrier pipe will not be allowed to be in contact with the encasement. The Engineer must be present to observe the entire installation of the carrier pipe.

**Page 15-19, Sub-article 1550-4 (A) Bore and Jack:**

add the following paragraphs after line 45:

As the boring operation progresses each new section of encasement pipe shall be butt welded to the previously installed section. Voids are to be filled with a Portland cement grout consisting of one (1) part Portland cement grout to three (3) parts sand at sufficient pressure to insure there will be no settlement of the highway or railroad. In the event that an obstruction is encountered during the dry boring operation, the auger is to be withdrawn, the excess pipe cut off and capped, and the pipe abandoned by completely filling the void with Portland cement grout as described above.

Encasement pipe installed either trenchless or by open-cut shall be installed prior to laying the carrier pipe within 50 feet of either end of the encasement. The Contractor is responsible for using the methods and equipment needed to attain the alignment, grade and elevation shown on the Engineer's drawings. Any deviations shall be corrected at the Contractor's expense.

Additional attempts may be required at alternate locations as directed by the Engineer. The option to install the encasement by open cutting shall not be permitted unless approved by the Engineer and, when applicable, the North Carolina Department of Transportation. If approved, open-cut encasement shall be installed per Section 1505 for excavation, trenching, pipe laying and backfill.



**General:**

The following utility companies have facilities that will be in conflict with the construction of this project:

- A. Duke Energy – Power (Distribution)
- B. Duke Energy – Power (Transmission)
- C. ATT Distribution
- D. Century Link
- E. Time Warner
- F. Piedmont Natural Gas

The conflicting facilities of these concerns will be adjusted prior to the date of availability, unless otherwise noted and are therefore listed in these special provisions for the benefit of the Contractor. All utility work listed herein will be done by the utility owners. All utilities are shown on the plans from the best available information.

The Contractor’s attention is directed to Article 105.8 of the Standard Specifications.

**Utilities Requiring Adjustment:**

Utility relocations are shown on the Utility by Others Plans.

A) Duke Energy – Power (Distribution)

Contact Information: Patrick Sizemore  
336-917-2522  
Patrick.sizemore@duke-energy.com

- 1) See Utilities by Others Plans.
- 2) Duke Energy will need 90 days to complete relocation work.
- 3) **Delayed completion due to DOE pending court order. Possible delays to relocation work!**

B) Duke Energy – Power (Transmission)

Contact Information: Jeremy Sabo  
526 South Church St.  
Charlotte, NC 28202  
704-382-8396  
Jeremy.sabo@duke-energy.com

1. See Utilities by Others Plans.
2. Duke Transmission owns and maintains 100kv Transmission lines within project limits.
3. Duke Transmission will install 199' poles to provide clearance requested by the Division. Duke Transmission will be responsible FAA permits.
4. Duke Transmission will complete necessary pole and tower replacements prior to LET (10-31-2017)
5. Duke Transmission will begin relocation work by April 1, 2017 and be completed by 10-31-2017.
6. Close coordination and communication will be needed with Duke Transmission that will involve several internal departments within Duke. Contractor must maintain a minimum of 15' of clearance from lowest conductor at all times. The contractor is advised of special conditions which will affect work at the site of this bridge. The contractor is responsible for meeting all OSHA (29 CFR 1926.1407-1411) requirements for working in the proximity of power lines.
7. Caution Note: Although the Transmission line may be de-energized during construction after proper notification to Duke Transmission, this line will remain in place and any caution will be needed when working in vicinity line. Minimum approach distances must be maintained at all times. The contractor shall place High Voltage Overhead Power signs inside the project limits. Do not assume the lines are grounded unless ground lines are in place and Duke Energy confirms lines are de-energized and grounded.

C) AT&T Distribution

Contact Information: Jim Brooks  
Telics  
117 Canterbury Drive  
Winston Salem, NC 27107  
336-788-0150  
ticswnst@bellsouth.net

1. See Utilities by Others Plans.
2. AT&T will be joint use onto Duke Energy Distribution poles.
3. **Delayed completion due to DOE pending court order. Possible delays to relocation work!**

D) Century Link

Contact Information: William Lee Price  
229 Hollingsworth St.  
Eden, NC 27288

336-623-6533

[lee.price@centurylink.com](mailto:lee.price@centurylink.com)

1. See Utilities by Others Plans.
2. Century Link is joint use on Duke Energy's Distribution poles as well as some underground facilities.
3. Century Link will relocate to Duke Energy's poles once Duke's poles are set and Distribution Lines are attached.
4. Century Link will need 30 days to complete relocations.
5. **Delayed completion due to DOE pending court order. Possible delays to relocation work!**

E) Time Warner Cable

Contact Information:

Eric Vivod

1410 Trade Mart Blvd.

Winston Salem, NC 27127

336-231-6109

[Eric.vivod@twcable.com](mailto:Eric.vivod@twcable.com)

1. See Utilities by Others Plans.
2. Time Warner facilities will be joint use on Duke Distribution poles.
3. Time Warner will need 30 days to complete relocation work once Duke Distribution poles are set.
4. **Delayed completion due to DOE pending court order. Possible delays to relocation work!**

F) Piedmont Natural Gas (PNG)

Contact Information:

Jason Brown

4720 Piedmont Row Drive

Charlotte, NC 28210

704-731-4681

[jason.brown@piedmontng.com](mailto:jason.brown@piedmontng.com)

1. See Utilities by Others Plans.
2. Piedmont Natural Gas will be responsible for acquiring all their necessary ROW.
3. Piedmont Natural Gas will require 6 – 8 weeks to complete relocations and installations of new Gas line.



**Project Special Provisions  
Erosion Control**

**STABILIZATION REQUIREMENTS:**

(3-11-2016)

Stabilization for this project shall comply with the time frame guidelines as specified by the NCG-010000 general construction permit effective August 1, 2016 issued by the North Carolina Department of Environment and Natural Resources Division of Water Quality. Temporary or permanent ground cover stabilization shall occur within 7 calendar days from the last land-disturbing activity, with the following exceptions in which temporary or permanent ground cover shall be provided in 14 calendar days from the last land-disturbing activity:

- Slopes between 2:1 and 3:1, with a slope length of 10 ft. or less
- Slopes 3:1 or flatter, with a slope of length of 50 ft. or less
- Slopes 4:1 or flatter

The stabilization timeframe for High Quality Water (HQW) Zones shall be 7 calendar days with no exceptions for slope grades or lengths. High Quality Water Zones (HQW) Zones are defined by North Carolina Administrative Code 15A NCAC 04A.0105 (25). Temporary and permanent ground cover stabilization shall be achieved in accordance with the provisions in this contract and as directed.

**SEEDING AND MULCHING:**

**(West)**

The kinds of seed and fertilizer, and the rates of application of seed, fertilizer, and limestone, shall be as stated below. During periods of overlapping dates, the kind of seed to be used shall be determined. All rates are in pounds per acre.

**Shoulder and Median Areas**

**August 1 - June 1**

20#	Kentucky Bluegrass
75#	Hard Fescue
25#	Rye Grain
500#	Fertilizer
4000#	Limestone

**May 1 - September 1**

20#	Kentucky Bluegrass
75#	Hard Fescue
10#	German or Browntop Millet
500#	Fertilizer
4000#	Limestone

**Areas Beyond the Mowing Pattern, Waste and Borrow Areas:**

**August 1 - June 1**

100#	Tall Fescue
15#	Kentucky Bluegrass
30#	Hard Fescue
25#	Rye Grain
500#	Fertilizer

**May 1 - September 1**

100#	Tall Fescue
15#	Kentucky Bluegrass
30#	Hard Fescue
10#	German or Browntop Millet
500#	Fertilizer

4000#          Limestone                                  4000#          Limestone

Approved Tall Fescue Cultivars

06 Dust	Escalade	Justice	Serengeti
2 <sup>nd</sup> Millennium	Essential	Kalahari	Shelby
3 <sup>rd</sup> Millennium	Evergreen 2	Kitty Hawk 2000	Sheridan
Apache III	Falcon IV	Legitimate	Signia
Avenger	Falcon NG	Lexington	Silver Hawk
Barlexas	Falcon V	LSD	Sliverstar
Barlexas II	Faith	Magellan	Shenandoah Elite
Bar Fa	Fat Cat	Matador	Sidewinder
Barrera	Festnova	Millennium SRP	Skyline
Barrington	Fidelity	Monet	Solara
Barrobusto	Finelawn Elite	Mustang 4	Southern Choice II
Barvado	Finelawn Xpress	Ninja 2	Speedway
Biltmore	Finesse II	Ol' Glory	Spyder LS
Bingo	Firebird	Olympic Gold	Sunset Gold
Bizem	Firecracker LS	Padre	Taccoa
Blackwatch	Firenza	Patagonia	Tanzania
Blade Runner II	Five Point	Pedigree	Trio
Bonsai	Focus	Picasso	Tahoe II
Braveheart	Forte	Piedmont	Talladega
Bravo	Garrison	Plantation	Tarheel
Bullseye	Gazelle II	Proseeds 5301	Terrano
Cannavaro	Gold Medallion	Prospect	Titan ltd
Catalyst	Grande 3	Pure Gold	Titanium LS
Cayenne	Greenbrooks	Quest	Tracer
Cessane Rz	Greenkeeper	Raptor II	Traverse SRP
Chipper	Gremlin	Rebel Exeda	Tulsa Time
Cochise IV	Greystone	Rebel Sentry	Turbo
Constitution	Guardian 21	Rebel IV	Turbo RZ
Corgi	Guardian 41	Regiment II	Tuxedo RZ
Corona	Hemi	Regenerate	Ultimate
Coyote	Honky Tonk	Rendition	Venture
Darlington	Hot Rod	Rhambler 2 SRP	Umbrella
Davinci	Hunter	Rembrandt	Van Gogh
Desire	Inferno	Reunion	Watchdog
Dominion	Innovator	Riverside	Wolfpack II
Dynamic	Integrity	RNP	Xtremegreen
Dynasty	Jaguar 3	Rocket	
Endeavor	Jamboree	Scorpion	

Approved Kentucky Bluegrass Cultivars:

4-Season	Blue Velvet	Gladstone	Quantum Leap
Alexa II	Blueberry	Granite	Rambo
America	Boomerang	Hampton	Rhapsody
Apollo	Brilliant	Harmonie	Rhythm
Arcadia	Cabernet	Impact	Rita
Aries	Champagne	Jefferson	Royce
Armada	Champlain	Juliet	Rubicon
Arrow	Chicago II	Jump Start	Rugby II
Arrowhead	Corsair	Keeneland	Shiraz
Aura	Courtyard	Langara	Showcase
Avid	Delight	Liberator	Skye
Award	Diva	Madison	Solar Eclipse
Awesome	Dynamo	Mercury	Sonoma
Bandera	Eagleton	Midnight	Sorbonne
Barduke	Emblem	Midnight II	Starburst
Barnique	Empire	Moon Shadow	Sudden Impact
Baroness	Envicta	Moonlight SLT	Total Eclipse
Barrister	Everest	Mystere	Touche
Barvette HGT	Everglade	Nu Destiny	Tsunami
Bedazzled	Excursion	NuChicago	Unique
Belissimo	Freedom II	NuGlade	Valor
Bewitched	Freedom III	Odyssey	Voyager II
Beyond	Front Page	Perfection	Washington
Blacksburg II	Futurity	Pinot	Zinfandel
Blackstone	Gaelic	Princeton 105	
Blue Note	Ginney II	Prosperity	

Approved Hard Fescue Cultivars:

Aurora II	Eureka II	Oxford	Scaldis II
Aurora Gold	Firefly	Reliant II	Spartan II
Berkshire	Granite	Reliant IV	Stonehenge
Bighorn GT	Heron	Rescue 911	
Chariot	Nordic	Rhino	

On cut and fill slopes 2:1 or steeper add 20# Sericea Lespedeza January 1 - December 31.

Fertilizer shall be 10-20-20 analysis. A different analysis of fertilizer may be used provided the 1-2-2 ratio is maintained and the rate of application adjusted to provide the same amount of plant food as a 10-20-20 analysis and as directed.

**Native Grass Seeding And Mulching**

**(West)**

Native Grass Seeding and Mulching shall be performed on the disturbed areas of wetlands and riparian areas, and adjacent to Stream Relocation and/or trout stream construction within a 50 foot zone on both sides of the stream or depression, measured from top of stream bank or center of

depression. The stream bank of the stream relocation shall be seeded by a method that does not alter the typical cross section of the stream bank. Native Grass Seeding and Mulching shall also be performed in the permanent soil reinforcement mat section of preformed scour holes, and in other areas as directed.

The kinds of seed and fertilizer, and the rates of application of seed, fertilizer, and limestone, shall be as stated below. During periods of overlapping dates, the kind of seed to be used shall be determined. All rates are in pounds per acre.

<b>August 1 - June 1</b>		<b>May 1 – September 1</b>	
18#	Creeping Red Fescue	18#	Creeping Red Fescue
8#	Big Bluestem	8#	Big Bluestem
6#	Indiangrass	6#	Indiangrass
4#	Switchgrass	4#	Switchgrass
35#	Rye Grain	25#	German or Browntop Millet
500#	Fertilizer	500#	Fertilizer
4000#	Limestone	4000#	Limestone

Approved Creeping Red Fescue Cultivars:

Aberdeen                      Boreal                      Epic                      Cindy Lou

Fertilizer shall be 10-20-20 analysis. A different analysis of fertilizer may be used provided the 1-2-2 ratio is maintained and the rate of application adjusted to provide the same amount of plant food as a 10-20-20 analysis and as directed.

Native Grass Seeding and Mulching shall be performed in accordance with Section 1660 of the *Standard Specifications* and vegetative cover sufficient to restrain erosion shall be installed immediately following grade establishment.

**Measurement and Payment**

Native Grass *Seeding and Mulching* will be measured and paid for in accordance with Article 1660-8 of the *Standard Specifications*.

**TEMPORARY SEEDING:**

Fertilizer shall be the same analysis as specified for *Seeding and Mulching* and applied at the rate of 400 pounds and seeded at the rate of 50 pounds per acre. German Millet, or Browntop Millet shall be used in summer months and rye grain during the remainder of the year. The Engineer will determine the exact dates for using each kind of seed.

**FERTILIZER TOPDRESSING:**

Fertilizer used for topdressing shall be 16-8-8 grade and shall be applied at the rate of 500 pounds per acre. A different analysis of fertilizer may be used provided the 2-1-1 ratio is maintained and

the rate of application adjusted to provide the same amount of plant food as 16-8-8 analysis and as directed.

**SUPPLEMENTAL SEEDING:**

The kinds of seed and proportions shall be the same as specified for *Seeding and Mulching*, and the rate of application may vary from 25# to 75# per acre. The actual rate per acre will be determined prior to the time of topdressing and the Contractor will be notified in writing of the rate per acre, total quantity needed, and areas on which to apply the supplemental seed. Minimum tillage equipment, consisting of a sod seeder shall be used for incorporating seed into the soil as to prevent disturbance of existing vegetation. A clodbuster (ball and chain) may be used where degree of slope prevents the use of a sod seeder.

**MOWING:**

The minimum mowing height on this project shall be six inches.

**LAWN TYPE APPEARANCE:**

All areas adjacent to lawns must be hand finished as directed to give a lawn type appearance. Remove all trash, debris, and stones  $\frac{3}{4}$ " and larger in diameter or other obstructions that could interfere with providing a smooth lawn type appearance. These areas shall be reseeded to match their original vegetative conditions, unless directed otherwise by the Field Operations Engineer.

**REFORESTATION:**

**Description**

*Reforestation* will be planted within interchanges and along the outside borders of the road, and in other areas as directed. *Reforestation* is not shown on the plan sheets. See the Reforestation Detail Sheet.

All non-maintained riparian buffers impacted by the placement of temporary fill or clearing activities shall be restored to the preconstruction contours and revegetated with native woody species.

The entire *Reforestation* operation shall comply with the requirements of Section 1670 of the *Standard Specifications*.

**Materials**

*Reforestation* shall be bare root seedlings 12"-18" tall.

**Construction Methods**

*Reforestation* shall be planted as soon as practical following permanent *Seeding and Mulching*. The seedlings shall be planted in a 16-foot wide swath adjacent to mowing pattern line, or as directed.

Root dip: The roots of reforestation seedlings shall be coated with a slurry of water, and either a fine clay (kaolin) or a superabsorbent that is designated as a bare root dip. The type, mixture ratio, method of application, and the time of application shall be submitted to the Engineer for approval.

With the approval of the Engineer, seedlings may be coated before delivery to the job or at the time of planting, but at no time shall the roots of the seedlings be allowed to dry out. The roots shall be moistened immediately prior to planting.

Seasonal Limitations: *Reforestation* shall be planted from November 15 through March 15.

**Measurement and Payment**

*Reforestation* will be measured and paid for in accordance with Article 1670-17 of the *Standard Specifications*.

**RESPONSE FOR EROSION CONTROL:****Description**

Furnish the labor, materials, tools and equipment necessary to move personnel, equipment, and supplies to the project necessary for the pursuit of any or all of the following work as shown herein, by an approved subcontractor.

<b>Section</b>	<b>Erosion Control Item</b>	<b>Unit</b>
1605	Temporary Silt Fence	LF
1606	Special Sediment Control Fence	LF/TON
1615	Temporary Mulching	ACR
1620	Seed - Temporary Seeding	LB
1620	Fertilizer - Temporary Seeding	TN
1631	Matting for Erosion Control	SY
SP	Coir Fiber Mat	SY
1640	Coir Fiber Baffles	LF
SP	Permanent Soil Reinforcement Mat	SY
1660	Seeding and Mulching	ACR
1661	Seed - Repair Seeding	LB

1661	Fertilizer - Repair Seeding	TON
1662	Seed - Supplemental Seeding	LB
1665	Fertilizer Topdressing	TON
SP	Safety/Highly Visible Fencing	LF
SP	Response for Erosion Control	EA

**Construction Methods**

Provide an approved subcontractor who performs an erosion control action as described in the NPDES Inspection Form SPPP30. Each erosion control action may include one or more of the above work items.

**Measurement and Payment**

*Response for Erosion Control* will be measured and paid for by counting the actual number of times the subcontractor moves onto the project, including borrow and waste sites, and satisfactorily completes an erosion control action described in Form 1675. The provisions of Article 104-5 of the *Standard Specifications* will not apply to this item of work.

Payment will be made under:

<b>Pay Item</b>	<b>Pay Unit</b>
Response for Erosion Control	Each

**MINIMIZE REMOVAL OF VEGETATION:**

The Contractor shall minimize removal of vegetation within project limits to the maximum extent practicable. Vegetation along stream banks and adjacent to other jurisdictional resources outside the construction limits shall only be removed upon approval of Engineer. No additional payment will be made for this minimization work.

**STOCKPILE AREAS:**

The Contractor shall install and maintain erosion control devices sufficient to contain sediment around any erodible material stockpile areas as directed.

**ACCESS AND HAUL ROADS:**

At the end of each working day, the Contractor shall install or re-establish temporary diversions or earth berms across access/haul roads to direct runoff into sediment devices. Silt fence sections that are temporarily removed shall be reinstalled across access/haul roads at the end of each working day.

**WASTE AND BORROW SOURCES:**

Payment for temporary erosion control measures, except those made necessary by the Contractor's own negligence or for his own convenience, will be paid for at the appropriate contract unit price for the devices or measures utilized in borrow sources and waste areas.

No additional payment will be made for erosion control devices or permanent seeding and mulching in any commercial borrow or waste pit. All erosion and sediment control practices that may be required on a commercial borrow or waste site will be done at the Contractor's expense.

All offsite Staging Areas, Borrow and Waste sites shall be in accordance with "Borrow and Waste Site Reclamation Procedures for Contracted Projects" located at:

[http://www.ncdot.gov/doh/operations/dp\\_chief\\_eng/roadside/fieldops/downloads/Files/ContractedReclamationProcedures.pdf](http://www.ncdot.gov/doh/operations/dp_chief_eng/roadside/fieldops/downloads/Files/ContractedReclamationProcedures.pdf)

All forms and documents referenced in the "Borrow and Waste Site Reclamation Procedures for Contracted Projects" shall be included with the reclamation plans for offsite staging areas, and borrow and waste sites.

**TEMPORARY DIVERSION:**

This work consists of installation, maintenance, and cleanout of *Temporary Diversions* in accordance with Section 1630 of the *Standard Specifications*. The quantity of excavation for installation and cleanout will be measured and paid for as *Silt Excavation* in accordance with Article 1630-3 of the *Standard Specifications*.

**CLEAN WATER DIVERSION:****Description**

This work consists of installing, maintaining, and removing any and all material required for the construction of clean water diversions. The clean water diversions shall be used to direct water flowing from offsite around/away from specific area(s) of construction.

**Materials**

Refer to Division 10

<b>Item</b>	<b>Section</b>
Geotextile for Soil Stabilization, Type 4	1056

**Construction Methods**

The Contractor shall install the clean water diversions in accordance with the details in the plans and at locations indicated in the plans, and as directed. Upon installation, the excavated material



shall be immediately stabilized as provided in Section 1620 of the *Standard Specifications*. Other stabilization methods may be utilized with prior approval from the Engineer.

Line clean water diversion with geotextile unrolled in the direction of flow and lay smoothly but loosely on soil surface without creases. Bury top of slope geotextile edge in a trench at least 5" deep and tamp securely. Make vertical overlaps a minimum of 18" with upstream geotextile overlapping the downstream geotextile.

Secure geotextile with eleven gauge wire staples shaped into a *u* shape with a length of not less than 6" and a throat not less than 1" in width. Place staples along outer edges and throughout the geotextile a maximum of 3 ft. horizontally and vertically.

### **Measurement and Payment**

*Silt Excavation* will be measured and paid for in accordance with Article 1630-4 of the *Standard Specifications*.

*Geotextile for Soil Stabilization* will be measured and paid for in accordance with Article 270-4 of the *Standard Specifications*.

Stabilization of the excavated material will be paid for as *Temporary Seeding* as provided in Section 1620 of the *Standard Specifications*.

Such price and payment shall be considered full compensation for all work covered by this section including all materials, construction, maintenance, and removal of the clean water diversions.

### **SAFETY FENCE AND JURISDICTIONAL FLAGGING:**

#### **Description**

*Safety Fence* shall consist of furnishing materials, installing and maintaining polyethylene or polypropylene fence along the outside riparian buffer, wetland, or water boundary, or other boundaries located within the construction corridor to mark the areas that have been approved to infringe within the buffer, wetland, endangered vegetation, culturally sensitive areas or water. The fence shall be installed prior to any land disturbing activities.

Interior boundaries for jurisdictional areas noted above shall be delineated by stakes and highly visible flagging.

Jurisdictional boundaries at staging areas, waste sites, or borrow pits, whether considered outside or interior boundaries shall be delineated by stakes and highly visible flagging.

**Materials****(A) Safety Fencing**

Polyethylene or polypropylene fence shall be a highly visible preconstructed safety fence approved by the Engineer. The fence material shall have an ultraviolet coating.

Either wood posts or steel posts may be used. Wood posts shall be hardwood with a wedge or pencil tip at one end, and shall be at least 5 ft. in length with a minimum nominal 2" x 2" cross section. Steel posts shall be at least 5 ft. in length, and have a minimum weight of 0.85 lb/ft of length.

**(B) Boundary Flagging**

Wooden stakes shall be 4 feet in length with a minimum nominal 3/4" x 1-3/4" cross section. The flagging shall be at least 1" in width. The flagging material shall be vinyl and shall be orange in color and highly visible.

**Construction Methods**

No additional clearing and grubbing is anticipated for the installation of this fence. The fence shall be erected to conform to the general contour of the ground.

**(A) Safety Fencing**

Posts shall be set at a maximum spacing of 10 ft., maintained in a vertical position and hand set or set with a post driver. Posts shall be installed a minimum of 2 ft. into the ground. If hand set, all backfill material shall be thoroughly tamped. Wood posts may be sharpened to a dull point if power driven. Posts damaged by power driving shall be removed and replaced prior to final acceptance. The tops of all wood posts shall be cut at a 30-degree angle. The wood posts may, at the option of the Contractor, be cut at this angle either before or after the posts are erected.

The fence geotextile shall be attached to the wood posts with one 2" galvanized wire staple across each cable or to the steel posts with wire or other acceptable means.

Place construction stakes to establish the location of the safety fence in accordance with Article 105-9 or Article 801-1 of the *Standard Specifications*. No direct pay will be made for the staking of the safety fence. All stakeouts for safety fence shall be considered incidental to the work being paid for as "Construction Surveying", except that where there is no pay item for construction surveying, all safety fence stakeout will be performed by state forces.

The Contractor shall be required to maintain the safety fence in a satisfactory condition for the duration of the project as determined by the Engineer.

## (B) Boundary Flagging

Boundary flagging delineation of interior boundaries shall consist of wooden stakes on 25 feet maximum intervals with highly visible orange flagging attached. Stakes shall be installed a minimum of 6" into the ground. Interior boundaries may be staked on a tangent that runs parallel to buffer but must not encroach on the buffer at any location. Interior boundaries of hand clearing shall be identified with a different colored flagging to distinguish it from mechanized clearing.

Boundary flagging delineation of interior boundaries will be placed in accordance with Article 105-9 or Article 801-1 of the *Standard Specifications*. No direct pay will be made for delineation of the interior boundaries. This delineation will be considered incidental to the work being paid for as *Construction Surveying*, except that where there is no pay item or construction surveying the cost of boundary flagging delineation shall be included in the unit prices bid for the various items in the contract. Installation for delineation of all jurisdictional boundaries at staging areas, waste sites, or borrow pits shall consist of wooden stakes on 25 feet maximum intervals with highly visible orange flagging attached. Stakes shall be installed a minimum of 6" into the ground. Additional flagging may be placed on overhanging vegetation to enhance visibility but does not substitute for installation of stakes.

Installation of boundary flagging for delineation of all jurisdictional boundaries at staging areas, waste sites, or borrow pits shall be performed in accordance with Subarticle 230-4(B)(5) or Subarticle 802-2(F) of the *Standard Specifications*. No direct pay will be made for this delineation, as the cost of same shall be included in the unit prices bid for the various items in the contract.

The Contractor shall be required to maintain alternative stakes and highly visible flagging in a satisfactory condition for the duration of the project as determined by the Engineer.

**Measurement and Payment**

*Safety Fence* will be measured and paid as the actual number of linear feet of polyethylene or polypropylene fence installed in place and accepted. Such payment will be full compensation including but not limited to furnishing and installing fence geotextile with necessary posts and post bracing, staples, tie wires, tools, equipment and incidentals necessary to complete this work.

Payment will be made under:

**Pay Item**  
Safety Fence

**Pay Unit**  
Linear Foot

**PERMANENT SOIL REINFORCEMENT MAT:****Description**

This work consists of furnishing and placing *Permanent Soil Reinforcement Mat*, of the type specified, over previously prepared areas as directed.

## Materials

The product shall be a permanent erosion control reinforcement mat and shall be constructed of synthetic or a combination of coconut and synthetic fibers evenly distributed throughout the mat between a bottom UV stabilized netting and a heavy duty UV stabilized top net. The matting shall be stitched together with UV stabilized polypropylene thread to form a permanent three-dimensional structure. The mat shall have the following minimum physical properties:

Property	Test Method	Value	Unit
Light Penetration	ASTM D6567	9	%
Thickness	ASTM D6525	0.40	in
Mass Per Unit Area	ASTM D6566	0.55	lb/sy
Tensile Strength	ASTM D6818	385	lb/ft
Elongation (Maximum)	ASTM D6818	49	%
Resiliency	ASTM D1777	>70	%
UV Stability *	ASTM D4355	≥80	%
Porosity (Permanent Net)	ECTC Guidelines	≥85	%
Maximum Permissible Shear Stress (Vegetated)	Performance Bench Test	≥8.0	lb/ft <sup>2</sup>
Maximum Allowable Velocity (Vegetated)	Performance Bench Test	≥16.0	ft/s

\*ASTM D1682 Tensile Strength and % strength retention of material after 1000 hours of exposure.

Submit a certification (Type 1, 2, or 3) from the manufacturer showing:

- (A) the chemical and physical properties of the mat used, and
- (B) conformance of the mat with this specification.

## Construction Methods

Matting shall be installed in accordance with Subarticle 1631-3(B) of the *Standard Specifications*.

All areas to be protected with the mat shall be brought to final grade and seeded in accordance with Section 1660 of the *Standard Specifications*. The surface of the soil shall be smooth, firm, stable and free of rocks, clods, roots or other obstructions that would prevent the mat from lying in direct contact with the soil surface. Areas where the mat is to be placed will not need to be mulched.

## Measurement and Payment

*Permanent Soil Reinforcement Mat* will be measured and paid for as the actual number of square yards measured along the surface of the ground over which Permanent Soil Reinforcement Mat is installed and accepted. Overlaps will not be included in the measurement, and will be considered as incidental to the work. Such payment shall be full compensation for furnishing and installing the mat, including overlaps, and for all required maintenance.

Payment will be made under:

<b>Pay Item</b>	<b>Pay Unit</b>
Permanent Soil Reinforcement Mat	Square Yard

### **SKIMMER BASIN WITH BAFFLES:**

#### **Description**

Provide a skimmer basin to remove sediment from construction site runoff at locations shown in the erosion control plans. See the Skimmer Basin with Baffles Detail sheet provided in the erosion control plans. Work includes constructing sediment basin, installation of temporary slope drain pipe and coir fiber baffles, furnishing, installation and cleanout of skimmer, providing and placing stone pad on bottom of basin underneath skimmer device, providing and placing a geotextile spillway liner, providing coir fiber mat stabilization for the skimmer outlet, disposing of excess materials, removing temporary slope drain, coir fiber baffles, geotextile liner and skimmer device, backfilling basin area with suitable material and providing proper drainage when basin area is abandoned.

#### **Materials**

<b>Item</b>	<b>Section</b>
Stone for Erosion Control, Class B	1042
Geotextile for Soil Stabilization, Type 4	1056
Fertilizer for Temporary Seeding	1060-2
Seed for Temporary Seeding	1060-4
Seeding and Mulching	1060-4
Matting for Erosion Control	1060-8
Staples	1060-8
Coir Fiber Mat	1060-14
Temporary Slope Drain	1622-2
Coir Fiber Baffle	1640

Provide appropriately sized and approved skimmer device.

Provide Schedule 40 PVC pipe with a length of 6 ft. to attach to the skimmer and the coupling connection to serve as the arm pipe. For skimmer sizes of 2.5 in. and smaller, the arm pipe diameter shall be 1.5 inches. For skimmer sizes of 3 in. and larger, refer to manufacturer recommendation.

Provide 4" diameter Schedule 40 PVC pipe to attach to coupling connection of skimmer to serve as the barrel pipe through the earthen dam.

Anchors: Staples, stakes, or reinforcement bars shall be used as anchors.

**Wooden Stakes:**

Provide hardwood stakes 12"- 24" long with a 2" x 2" nominal square cross section. One end of the stake must be sharpened or beveled to facilitate driving through the coir fiber mat and down into the underlying soil. The other end of the stake needs to have a 1"- 2" long head at the top with a 1"- 2" notch following to catch and secure the coir fiber mat.

**Steel Reinforcement Bars:**

Provide uncoated #10 steel reinforcement bars 24" nominal length. The bars shall have a 4" diameter bend at one end with a 4" straight section at the tip to catch and secure the coir fiber mat.

**Staples:**

Provide staples made of 0.125" diameter new steel wire formed into a *u* shape not less than 12" in length with a throat of 1" in width.

**Construction Methods**

Excavate basin according to the erosion control plans with basin surface free of obstructions, debris, and pockets of low-density material. Install temporary slope drain pipe and construct the primary spillway according to the Skimmer Basin with Baffles Detail sheet in the erosion control plans. Temporary slope drain pipe at inlet of basin may be replaced by geotextile as directed. Construct the coir fiber baffles according to *Roadway Standard Drawings* No. 1640.01 and Section 1640 of the *Standard Specifications*.

Install skimmer device according to manufacturer recommendations. Install 4" Schedule 40 PVC pipe into dam on the lower side of basin 1 ft. from the bottom of the basin and according to the detail, and extend the pipe so the basin will drain. Attach a 6 ft. arm pipe to the coupling connection and skimmer according to manufacturer recommendations. The coupling shall be rigid and non-buoyant and not exceed a diameter of 4" and 12" in length. Attach the rope included with the skimmer to the tee between the vent socket and the tube inlet, and the other end to a wooden stake or metal post. Clean out skimmer device when it becomes clogged with sediment and/or debris and is unable to float at the top of water in skimmer basin. Take appropriate measures to avoid ice accumulation in the skimmer device. Construct a stone pad of Class B stone directly underneath the skimmer device at bottom of basin. The pad shall be a minimum of 12" in height, and shall have a minimum cross sectional area of 4 ft. by 4 ft.

Line primary spillway with geotextile unrolled in the direction of flow and lay smoothly but loosely on soil surface without creases. Bury edges of geotextile in a trench at least 5" deep and tamp firmly. If geotextile for the primary spillway is not one continuous piece of material, make horizontal overlaps a minimum of 18" with upstream geotextile overlapping the downstream geotextile. Secure geotextile with eleven gauge wire staples shaped into a *u* shape with a length of not less than 12" and a throat not less than 1" in width. Place staples along outer edges and throughout the geotextile a maximum of 3 ft. horizontally and vertically. Geotextile shall be placed

to the bottom and across the entire width of the basin according to the Skimmer Basin with Baffles detail. Place sealant inside basin around barrel pipe on top of geotextile with a minimum width of 6 in.

At the skimmer outlet, provide a smooth soil surface free from stones, clods, or debris that will prevent contact of the coir fiber matting with the soil. Unroll the matting and apply without stretching such that it will lie smoothly but loosely on the soil surface. Wooden stakes, reinforcement bars, or staples may be used as anchors in accordance with the details in the plans and as directed. Place anchors across the matting at the ends approximately 1 ft. apart. Place anchors along the outer edges and down the center of the matting 3 ft. apart.

All bare side slope sections of the skimmer basin shall be seeded with a temporary or permanent seed mix as directed and in accordance with Articles 1620-3, 1620-4, 1620-5, 1660-4, 1660-5 and 1660-7 of the *Standard Specifications*. Straw or excelsior matting shall be installed on all bare side slope sections immediately upon the completion of seeding and in accordance with Article 1631-3 of the *Standard Specifications*.

### **Measurement and Payment**

*Silt Excavation* will be measured and paid for in accordance with Article 1630-4 of the *Standard Specifications*, as calculated from the typical section throughout the length of the basin as shown on the final approved plans.

*Geotextile for Soil Stabilization* will be measured and paid for in accordance with Article 270-4 of the *Standard Specifications*.

*Coir Fiber Baffles* will be measured and paid for in accordance with Article 1640-4 of the *Standard Specifications*.

\_\_\_" *Skimmer* will be measured in units of each. \_\_\_" *Skimmer* will be measured and paid for as the maximum number of each size skimmer acceptably installed and in use at any one time during the life of the project. Barrel and arm pipe, cleanout, relocation and reinstallation of \_\_\_" *Skimmer* is considered incidental to the measurement of the quantity of \_\_\_" *Skimmer* and no separate payment will be made. No separate payment shall be made if \_\_\_" *Skimmer*, barrel and/or arm pipe(s) are damaged by ice accumulation.

*Coir Fiber Mat* will be measured and paid for as the actual number of square yards measured along the surface of the ground over which coir fiber mat is installed and accepted.

*Temporary Slope Drain* will be measured and paid for in accordance with Article 1622-4 of the *Standard Specifications*.

*Stone for Erosion Control, Class \_\_\_* will be measured and paid for in accordance with Article 1610-4 of the *Standard Specifications*.

*Seeding and Mulching* will be measured and paid for in accordance with Article 1660-8 of the *Standard Specifications*.

*Seed for Temporary Seeding* will be measured and paid for in accordance with Article 1620-6 of the *Standard Specifications*.

*Fertilizer for Temporary Seeding* will be measured and paid for in accordance with Article 1620-6 of the *Standard Specifications*.

*Matting for Erosion Control* will be measured and paid for in accordance with Article 1631-4 of the *Standard Specifications*.

No measurement will be made for other items or for over excavation or stockpiling.

Payment will be made under:

<b>Pay Item</b>	<b>Pay Unit</b>
___" Skimmer	Each
Coir Fiber Mat	Square Yard

**TIERED SKIMMER BASIN WITH BAFFLES:**

**Description**

Provide a tiered skimmer basin to remove sediment from construction site runoff at locations shown in the erosion control plans. See the Tiered Skimmer Basin Detail sheet provided in the erosion control plans. Tiered Skimmer Basins shall be installed in areas where topography creates a large elevation difference between the inlet and outlet of a single skimmer basin. Work includes constructing sediment basins, installation of coir fiber baffles, installation of temporary slope drain pipe, furnishing, installation and cleanout of skimmer, providing and placing stone pad on bottom of basin underneath skimmer device, providing and placing geotextile spillway liners, providing coir fiber mat stabilization for the skimmer outlet, disposing of excess materials, removing temporary slope drain pipe, coir fiber baffles, geotextile liner and skimmer device, backfilling basin area with suitable material and providing proper drainage when basin area is abandoned.

**Materials**

<b>Item</b>	<b>Section</b>
Stone for Erosion Control, Class B	1042
Geotextile for Soil Stabilization, Type 4	1056
Fertilizer for Temporary Seeding	1060-2
Seed for Temporary Seeding	1060-4
Seeding and Mulching	1060-4
Matting for Erosion Control	1060-8
Staples	1060-8
Coir Fiber Mat	1060-14



Temporary Slope Drain  
Coir Fiber Baffle

1622-2  
1640

Provide appropriately sized and approved skimmer device.

Provide Schedule 40 PVC pipe with a length of 6 ft. to attach to the skimmer and the coupling connection to serve as the arm pipe. For skimmer sizes of 2.5 in. and smaller, the arm pipe diameter shall be 1.5 inches. For skimmer sizes of 3 in. and larger, refer to manufacturer recommendation.

Provide 4" diameter Schedule 40 PVC pipe to attach to coupling connection of skimmer to serve as the barrel pipe through the earthen dam.

Anchors: Staples, stakes, or reinforcement bars shall be used as anchors.

#### Wooden Stakes:

Provide hardwood stakes 12" - 24" long with a 2" x 2" nominal square cross section. One end of the stake must be sharpened or beveled to facilitate driving through the coir fiber mat and down into the underlying soil. The other end of the stake needs to have a 1" - 2" long head at the top with a 1" - 2" notch following to catch and secure the coir fiber mat.

#### Steel Reinforcement Bars:

Provide uncoated #10 steel reinforcement bars 24" nominal length. The bars shall have a 4" diameter bend at one end with a 4" straight section at the tip to catch and secure the coir fiber mat.

#### Staples:

Provide staples made of 0.125" diameter new steel wire formed into a *u* shape not less than 12" in length with a throat of 1" in width.

### Construction Methods

Excavate basins according to the erosion control plans with basin surface free of obstructions, debris, and pockets of low-density material. Install temporary slope drain pipe and construct the primary spillways according to the Tiered Skimmer Basin Detail sheet in the erosion control plans. Construct the coir fiber baffles according to *Roadway Standard Drawings* No. 1640.01 and Section 1640 of the *Standard Specifications*. Multiple upper basins, or Modified Silt Basins Type 'B' as labeled on the detail, may be required based on site conditions and as directed.

Install skimmer device according to manufacturer recommendations. Install 4" Schedule 40 PVC pipe into dam on the lower side of basin 1 ft. from the bottom of the basin and according to the detail, and extend the pipe so the basin will drain. Attach a 6 ft. arm pipe to the coupling connection and skimmer according to manufacturer recommendations. The coupling shall be rigid and non-buoyant and not exceed a diameter of 4" and 12" in length. Attach the rope included with the

skimmer to the tee between the vent socket and the tube inlet, and the other end to a wooden stake or metal post. Clean out skimmer device when it becomes clogged with sediment and/or debris and is unable to float at the top of water in skimmer basin. Take appropriate measures to avoid ice accumulation in the skimmer device. Construct a stone pad of Class B stone directly underneath the skimmer device at bottom of basin. The pad shall be a minimum of 12" in height, and shall have a minimum cross sectional area of 4 ft. by 4 ft.

Line primary spillways with geotextile unrolled in the direction of flow and lay smoothly but loosely on soil surface without creases. Bury edges of geotextile in a trench at least 5" deep and tamp firmly. If geotextile for primary spillways is not one continuous piece of material, make horizontal overlaps a minimum of 18" with upstream geotextile overlapping the downstream geotextile. Secure geotextile with eleven gauge wire staples shaped into a *u* shape with a length of not less than 12" and a throat not less than 1" in width. Place staples along outer edges and throughout the geotextile a maximum of 3 ft. horizontally and vertically. Geotextile shall be placed to the bottom and across the entire width of the basin according to the Tiered Skimmer Basin with Baffles detail.

At the skimmer outlet, provide a smooth soil surface free from stones, clods, or debris that will prevent contact of the coir fiber matting with the soil. Unroll the matting and apply without stretching such that it will lie smoothly but loosely on the soil surface. Wooden stakes, reinforcement bars, or staples may be used as anchors in accordance with the details in the plans and as directed. Place anchors across the matting at the ends approximately 1 ft. apart. Place anchors along the outer edges and down the center of the matting 3 ft. apart. Place sealant inside basin around barrel pipe on top of geotextile with a minimum width of 6 in.

All bare side slope sections of the skimmer basin shall be seeded with a temporary or permanent seed mix as directed and in accordance with Articles 1620-3, 1620-4, 1620-5, 1660-4, 1660-5 and 1660-7 of the *Standard Specifications*. Straw or excelsior matting shall be installed on all bare side slope sections immediately upon the completion of seeding and in accordance with Article 1631-3 of the *Standard Specifications*.

### **Measurement and Payment**

*Silt Excavation* will be measured and paid for in accordance with Article 1630-4 of the *Standard Specifications*, as calculated from the typical section throughout the length of the basin as shown on the final approved plans.

*Geotextile for Soil Stabilization* will be measured and paid for in accordance with Article 270-4 of the *Standard Specifications*.

*Coir Fiber Baffles* will be measured and paid for in accordance with Article 1640-4 of the *Standard Specifications*.

\_\_\_" *Skimmer* will be measured in units of each. \_\_\_" *Skimmer* will be measured and paid for as the maximum number of each size skimmer acceptably installed and in use at any one time during the life of the project. Barrel and arm pipe, cleanout, relocation and reinstallation of \_\_\_" *Skimmer* is

considered incidental to the measurement of the quantity of \_\_\_" *Skimmer* and no separate payment will be made. No separate payment shall be made if \_\_\_" *Skimmer*, barrel and/or arm pipe(s) are damaged by ice accumulation.

*Coir Fiber Mat* will be measured and paid for as the actual number of square yards measured along the surface of the ground over which coir fiber mat is installed and accepted.

*Temporary Slope Drain* will be measured and paid for in accordance with Article 1622-4 of the *Standard Specifications*.

*Stone for Erosion Control, Class \_\_\_* will be measured and paid for in accordance with Article 1610-4 of the *Standard Specifications*.

*Seeding and Mulching* will be measured and paid for in accordance with Article 1660-8 of the *Standard Specifications*.

*Seed for Temporary Seeding* will be measured and paid for in accordance with Article 1620-6 of the *Standard Specifications*.

*Fertilizer for Temporary Seeding* will be measured and paid for in accordance with Article 1620-6 of the *Standard Specifications*.

*Matting for Erosion Control* will be measured and paid for in accordance with Article 1631-4 of the *Standard Specifications*.

No measurement will be made for other items or for over excavation or stockpiling.

Payment will be made under:

<b>Pay Item</b>	<b>Pay Unit</b>
___" Skimmer	Each
Coir Fiber Mat	Square Yard

**STORMWATER BASIN EROSION CONTROL:**

**Description**

Provide a skimmer to remove sediment from construction site runoff in permanent stormwater basins at locations shown in the erosion control plans. Work includes constructing basin, installation of coir fiber baffles, furnishing, installation and cleanout of skimmer, providing and placing stone pad on bottom of basin underneath skimmer device, stabilizing side slopes of basin with matting and seed, disposing of excess materials, removing coir fiber baffles, and skimmer device.

**Materials**

<b>Item</b>	<b>Section</b>
Seeding and Mulching	1060-4
Matting for Erosion Control	1060-8
Staples	1060-8
Coir Fiber Baffle	1640

Provide appropriately sized and approved skimmer device.

Provide Schedule 40 PVC pipe with a length of 6 ft. to attach to the skimmer and the coupling connection to serve as the arm pipe. For skimmer sizes of 2.5 in. and smaller, the arm pipe diameter shall be 1.5 inches. For skimmer sizes of 3 in. and larger, refer to manufacturer recommendation.

Provide 4" diameter Schedule 40 PVC pipe to attach to coupling connection of skimmer to serve as the barrel pipe through the earthen dam.

**Construction Methods**

Construct permanent stormwater basin according to the plans with basin surface free of obstructions, debris, and pockets of low-density material. Construct the coir fiber baffles according to *Roadway Standard Drawings* No. 1640.01 and Section 1640 of the *Standard Specifications*.

Install skimmer device according to manufacturer recommendations. Install the coupling connection provided with the skimmer 1 ft. from the bottom of the basin and attach to permanent stormwater drainage structure. Attach the 6 ft. arm pipe to the coupling connection and skimmer according to manufacturer recommendations. The coupling shall be rigid and non-buoyant and not exceed a diameter of 4" and 12" in length. Attach the rope included with the skimmer to the tee between the vent socket and the tube inlet, and the other end to a wooden stake or metal post. Clean out skimmer device when it becomes clogged with sediment and/or debris and is unable to float at the top of water in basin. Take appropriate measures to avoid ice accumulation in the skimmer device. Construct a stone pad of Class B stone directly underneath the skimmer device at bottom of basin. The pad shall be a minimum of 12" in height, and shall have a minimum cross sectional area of 4 ft. by 4 ft.

All bare side slope sections of the stormwater basin shall be seeded with a permanent seed mix as directed and in accordance with Articles 1660-4, 1660-5 and 1660-7 of the *Standard Specifications*. Straw or excelsior matting shall be installed on all bare side slope sections immediately upon the completion of seeding and in accordance with Article 1631-3 of the *Standard Specifications*.

**Measurement and Payment**

*Silt Excavation* will be measured and paid for in accordance with Article 1630-4 of the *Standard Specifications*, as calculated from the typical section throughout the length of the basin as shown on the final approved plans.

*Coir Fiber Baffles* will be measured and paid for in Accordance with Article 1640-4 of the *Standard Specifications*.

\_\_" *Skimmer* will be measured in units of each. \_\_" *Skimmer* will be measured and paid for as the maximum number of each size skimmer acceptably installed and in use at any one time during the life of the project. Barrel and arm pipe, cleanout, relocation and reinstallation of \_\_" *Skimmer* is considered incidental to the measurement of the quantity of \_\_" *Skimmer* and no separate payment will be made. No separate payment shall be made if \_\_" *Skimmer*, barrel and/or arm pipe(s) are damaged by ice accumulation.

*Stone for Erosion Control, Class \_\_* will be measured and paid for in accordance with Article 1610-4 of the *Standard Specifications*.

*Seeding and Mulching* will be measured and paid for in accordance with Article 1660-8 of the *Standard Specifications*.

*Matting for Erosion Control* will be measured and paid for in accordance with Article 1631-4 of the *Standard Specifications*.

No measurement will be made for other items or for over excavation or stockpiling.

Payment will be made under:

<b>Pay Item</b>	<b>Pay Unit</b>
__" Skimmer	Each

**COIR FIBER WATTLES WITH POLYACRYLAMIDE (PAM):**

**Description**

Coir Fiber Wattles are tubular products consisting of coir fibers (coconut fibers) encased in coir fiber netting. Coir Fiber Wattles are used on slopes or channels to intercept runoff and act as a velocity break. Coir Fiber Wattles are to be placed at locations shown on the plans or as directed. Installation shall follow the detail provided in the plans and as directed. Work includes furnishing materials, installation of coir fiber wattles, matting installation, PAM application, and removing wattles.

**Materials**

Coir Fiber Wattle shall meet the following specifications:

100% Coir (Coconut) Fibers	
Minimum Diameter	12 in.
Minimum Density	3.5 lb/ft <sup>3</sup> +/- 10%
Net Material	Coir Fiber
Net Openings	2 in. x 2 in.
Net Strength	90 lbs.
Minimum Weight	2.6 lbs./ft. +/- 10%

Anchors: Stakes shall be used as anchors.

#### Wooden Stakes:

Provide hardwood stakes a minimum of 2-ft. long with a 2 in. x 2 in. nominal square cross section. One end of the stake must be sharpened or beveled to facilitate driving down into the underlying soil.

Matting shall meet the requirements of Article 1060-8 of the *Standard Specifications*, or shall meet specifications provided elsewhere in this contract.

Provide staples made of 0.125" diameter new steel wire formed into a *u* shape not less than 12" in length with a throat of 1" in width.

Polyacrylamide (PAM) shall be applied in powder form and shall be anionic or neutrally charged. Soil samples shall be obtained in areas where the wattles will be placed, and from offsite material used to construct the roadway, and analyzed for the appropriate PAM flocculant to be utilized with each wattle. The PAM product used shall be listed on the North Carolina Department of Environment and Natural Resources (NCDENR) Division of Water Quality (DWQ) web site as an approved PAM product for use in North Carolina.

#### Construction Methods

Coir Fiber Wattles shall be secured to the soil by wire staples approximately every 1 linear foot and at the end of each section of wattle. A minimum of 4 stakes shall be installed on the downstream side of the wattle with a maximum spacing of 2 linear feet along the wattle, and according to the detail. Install a minimum of 2 stakes on the upstream side of the wattle according to the detail provided in the plans. Stakes shall be driven into the ground a minimum of 10 in. with no more than 2 in. projecting from the top of the wattle. Drive stakes at an angle according to the detail provided in the plans.

Only install coir fiber wattle(s) to a height in ditch so flow will not wash around wattle and scour ditch slopes and according to the detail provided in the plans and as directed. Overlap adjoining sections of wattles a minimum of 6 in.

Installation of matting shall be in accordance with the detail provided in the plans, and in accordance with Article 1631-3 of the *Standard Specifications*, or in accordance with specifications provided elsewhere in this contract.

Apply PAM over the lower center portion of the coir fiber wattle where the water is going to flow over at a rate of 2 ounces per wattle, and 1 ounce of PAM on matting on each side of the wattle. PAM applications shall be done during construction activities after every rainfall event that is equal to or exceeds 0.50 in.

The Contractor shall maintain the coir fiber wattles until the project is accepted or until the wattles are removed, and shall remove and dispose of silt accumulations at the wattles when so directed in accordance with the requirements of Section 1630 of the *Standard Specifications*.

### **Measurement and Payment**

*Coir Fiber Wattles* will be measured and paid for by the actual number of linear feet of wattles which are installed and accepted. Such price and payment will be full compensation for all work covered by this section, including, but not limited to, furnishing all materials, labor, equipment and incidentals necessary to install the *Coir Fiber Wattles*.

Matting will be measured and paid for in accordance with Article 1631-4 of the *Standard Specifications*, or in accordance with specifications provided elsewhere in this contract.

*Polyacrylamide(PAM)* will be measured and paid for by the actual weight in pounds of PAM applied to the coir fiber wattles. Such price and payment will be full compensation for all work covered by this section, including, but not limited to, furnishing all materials, labor, equipment and incidentals necessary to apply the *Polyacrylamide(PAM)*.

Payment will be made under:

<b>Pay Item</b>	<b>Pay Unit</b>
Polyacrylamide(PAM)	Pound
Coir Fiber Wattle	Linear Foot

### **TEMPORARY ROCK SILT CHECK TYPE A WITH EXCELSIOR MATTING AND POLYACRYLAMIDE (PAM):**

#### **Description**

Temporary Rock Silt Checks Type A with Excelsior Matting and Polyacrylamide (PAM) are devices utilized in temporary and permanent ditches to reduce runoff velocity and incorporate PAM into the construction runoff to increase settling of sediment particles and reduce turbidity of runoff. Temporary Rock Silt Checks Type A with Excelsior Matting and PAM are to be placed at locations shown on the plans or as directed. Installation shall follow the detail provided in the plans and as directed. Work includes furnishing materials, installation of Temporary Rock Silt

Checks Type A, matting installation, PAM application, and removing Temporary Rock Silt Checks Type A with Excelsior Matting and PAM.

### **Materials**

Structural stone shall be class B stone that meets the requirements of Section 1042 of the *Standard Specifications* for Stone for Erosion Control, Class B.

Sediment control stone shall be #5 or #57 stone, which meets the requirements of Section 1005 of the *Standard Specifications* for these stone sizes.

Matting shall meet the requirements of Excelsior Matting in Subarticle 1060-8(B) of the *Standard Specifications*, or shall meet specifications provided elsewhere in this contract.

Polyacrylamide (PAM) shall be applied in powder form and shall be anionic or neutrally charged. Soil samples shall be obtained in areas where the Temporary Rock Silt Checks Type A with Excelsior Matting and PAM will be placed, and from offsite material used to construct the roadway, and analyzed for the appropriate PAM flocculant to be utilized with each Temporary Rock Silt Check Type A. The PAM product used shall be listed on the North Carolina Department of Environment and Natural Resources (NCDENR) Division of Water Quality (DWQ) web site as an approved PAM product for use in North Carolina.

### **Construction Methods**

Temporary Rock Silt Checks Type A shall be installed in accordance with Subarticle 1633-3(A) of the *Standard Specifications*, Roadway Standard Drawing No. 1633.01 and the detail provided in the plans.

Installation of matting shall be in accordance with the detail provided in the plans, and anchored by placing Class B stone on top of the matting at the upper and lower ends.

Apply PAM at a rate of 4 ounces over the center portion of the Temporary Rock Silt Checks Type A and matting where the water is going to flow over. PAM applications shall be done during construction activities and after every rainfall event that is equal to or exceeds 0.50 in.

The Contractor shall maintain the Temporary Rock Silt Checks Type A with Excelsior Matting and PAM until the project is accepted or until the Temporary Rock Silt Checks Type A with Excelsior Matting and PAM are removed, and shall remove and dispose of silt accumulations at the Temporary Rock Silt Checks Type A with Excelsior Matting and PAM when so directed in accordance with the requirements of Section 1630 of the *Standard Specifications*.

### **Measurement and Payment**

*Temporary Rock Silt Checks Type A* will be measured and paid for in accordance with Article 1633-5 of the *Standard Specifications*, or in accordance with specifications provided elsewhere in this contract.



Matting will be measured and paid for in accordance with Article 1631-4 of the *Standard Specifications*, or in accordance with specifications provided elsewhere in this contract.

*Polyacrylamide(PAM)* will be measured and paid for by the actual weight in pounds of PAM applied to the Temporary Rock Silt Checks Type A. Such price and payment will be full compensation for all work covered by this section, including, but not limited to, furnishing all materials, labor, equipment and incidentals necessary to apply the *Polyacrylamide(PAM)*.

Payment will be made under:

<b>Pay Item</b>	<b>Pay Unit</b>
Polyacrylamide(PAM)	Pound

**CULVERT DIVERSION CHANNEL:**

**Description**

This work consists of providing a *Culvert Diversion Channel* to detour the existing stream around the culvert construction site at locations shown on the plans. Work includes constructing the diversion channel, disposing of excess materials, providing and placing geotextile liner, maintaining the diversion area in an acceptable condition, removing geotextile liner, backfilling diversion channel area with suitable material, and providing proper drainage when diversion channel area is abandoned.

**Materials**

Refer to Division 10

<b>Item</b>	<b>Section</b>
Geotextile for Soil Stabilization, Type 4	1056

**Construction Methods**

Grade channel according to the plans with channel surface free of obstructions, debris, and pockets of low-density material. Utilize suitable material and provide disposal area for unsuitable material.

Line channel with geotextile unrolled in the direction of flow and lay smoothly but loosely on soil surface without creases. Bury top of slope geotextile edge in a trench at least 5" deep and tamp securely. Make vertical overlaps a minimum of 18" with upstream geotextile overlapping the downstream geotextile.

Secure geotextile with eleven gauge wire staples shaped into a *u* shape with a length of not less than 6" and a throat not less than 1" in width. Place staples along outer edges and throughout the geotextile a maximum of 3 ft. horizontally and vertically.

### Measurement and Payment

*Culvert Diversion Channel* will be measured and paid for as the actual number of cubic yards excavated, as calculated from the typical section throughout the length of the diversion channel as shown on the final approved plans.

*Geotextile for Soil Stabilization* will be measured and paid for in accordance with Article 270-4 of the *Standard Specifications*.

Such price and payment shall be considered full compensation for all work covered by this section including all materials, construction, maintenance, and removal of *Culvert Diversion Channel*.

Payment will be made under:

<b>Pay Item</b>	<b>Pay Unit</b>
Culvert Diversion Channel	Cubic Yard

### IMPERVIOUS DIKE:

#### Description

This work consists of furnishing, installing, maintaining, and removing an *Impervious Dike* for the purpose of diverting normal stream flow around the construction site. The Contractor shall construct an impervious dike in such a manner approved by the Engineer. The impervious dike shall not permit seepage of water into the construction site or contribute to siltation of the stream. The impervious dike shall be constructed of an acceptable material in the locations noted on the plans or as directed.

#### Materials

Acceptable materials shall include but not be limited to sheet piles, sandbags, and/or the placement of an acceptable size stone lined with polypropylene or other impervious geotextile.

Earth material shall not be used to construct an impervious dike when it is in direct contact with the stream unless vegetation can be established before contact with the stream takes place.

### Measurement and Payment

*Impervious Dike* will be measured and paid as the actual number of linear feet of impervious dike(s) constructed, measured in place from end to end of each separate installation that has been completed and accepted. Such price and payment will be full compensation for all work including but not limited to furnishing materials, construction, maintenance, and removal of the impervious dike.

Payment will be made under:

<b>Pay Item</b>	<b>Pay Unit</b>
Impervious Dike	Linear Foot

**TEMPORARY PIPE FOR CULVERT CONSTRUCTION:**

**Description**

This work consists of furnishing, installing, maintaining and removing any and all temporary pipe used on this project in conjunction with the culvert construction.

**Construction Methods**

The Contractor shall install temporary pipe in locations shown on the plans in such a manner approved by the Engineer. The temporary pipe shall provide a passageway for the stream through the work-site. The minimum size requirements will be as stated on the erosion control plans.

**Measurement and Payment**

*18" Temporary Pipe* will be measured and paid for at the contract unit price per linear foot of temporary pipe approved by the Engineer and measured in place from end to end. Such price and payment will be full compensation for all work covered by this section including but not limited to furnishing all materials required for installation, construction, maintenance, and removal of temporary pipe.

Payment will be made under:

<b>Pay Item</b>	<b>Pay Unit</b>
18" Temporary Pipe	Linear Foot

**COIR FIBER MAT:**

**Description**

Furnish material, install and maintain coir fiber mat in locations shown on the plans or in locations as directed. Work includes providing all materials, excavating and backfilling, and placing and securing coir fiber mat with stakes, steel reinforcement bars or staples as directed.

**Materials**

<b>Item</b>	<b>Section</b>
Coir Fiber Mat	1060-14

Anchors: Stakes, reinforcement bars, or staples shall be used as anchors.

**Wooden Stakes:**

Provide hardwood stakes 12"- 24" long with a 2" x 2" nominal square cross section. One end of the stake must be sharpened or beveled to facilitate driving through the coir fiber mat and down into the underlying soil. The other end of the stake needs to have a 1"- 2" long head at the top with a 1"- 2" notch following to catch and secure the coir fiber mat.

**Steel Reinforcement Bars:**

Provide uncoated #10 steel reinforcement bars 24" nominal length. The bars shall have a 4" diameter bend at one end with a 4" straight section at the tip to catch and secure the coir fiber mat.

**Staples:**

Provide staples made of 0.125" diameter new steel wire formed into a *u* shape not less than 12" in length with a throat of 1" in width.

**Construction Methods**

Place the coir fiber mat immediately upon final grading. Provide a smooth soil surface free from stones, clods, or debris that will prevent the contact of the mat with the soil. Unroll the mat and apply without stretching such that it will lie smoothly but loosely on the soil surface.

For stream relocation applications, take care to preserve the required line, grade, and cross section of the area covered. Bury the top slope end of each piece of mat in a narrow trench at least 6 in. deep and tamp firmly. Where one roll of matting ends and a second roll begins, overlap the end of the upper roll over the buried end of the second roll so there is a 6 in. overlap. Construct check trenches at least 12 in. deep every 50 ft. longitudinally along the edges of the mat or as directed. Fold over and bury mat to the full depth of the trench, close and tamp firmly. Overlap mat at least 6 in. where 2 or more widths of mat are installed side by side.

Place anchors across the mat at the ends approximately 1 ft. apart. Place anchors along the outer edges and down the center of the mat 3 ft. apart.

Adjustments in the trenching or anchoring requirements to fit individual site conditions may be required.

**Measurement and Payment**

*Coir Fiber Mat* will be measured and paid for as the actual number of square yards measured along the surface of the ground over which coir fiber mat is installed and accepted.

No measurement will be made for anchor items.

Payment will be made under:

**Pay Item**

Coir Fiber Mat

**Pay Unit**

Square Yard

**CONCRETE WASHOUT STRUCTURE:**

(12-01-15)

**Description**

Concrete washout structures are enclosures above or below grade to contain concrete waste water and associated concrete mix from washing out ready-mix trucks, drums, pumps, or other equipment. Concrete washouts must collect and retain all the concrete washout water and solids, so that this material does not migrate to surface waters or into the ground water. These enclosures are not intended for concrete waste not associated with wash out operations.

The concrete washout structure may include constructed devices above or below ground and or commercially available devices designed specifically to capture concrete waste water.

**Materials**

**Item**

Temporary Silt Fence

**Section**

1605

*Safety Fence* shall meet the specifications as provided elsewhere in this contract.

Geomembrane basin liner shall meet the following minimum physical properties for low permeability; it shall consist of a polypropylene or polyethylene 10 mil thick geomembrane. If the minimum setback dimensions can be achieved the liner is not required. (5 feet above groundwater, 50 feet from top of bank of perennial stream, other surface water body, or wetland.)

**Construction Methods**

Build an enclosed earthen berm or excavate to form an enclosure in accordance with the details and as directed.

Install temporary silt fence around the perimeter of the enclosure in accordance with the details and as directed if structure is not located in an area where existing erosion and sedimentation control devices are capable to containing any loss of sediment.

Post a sign with the words "Concrete Washout" in close proximity of the concrete washout area, so it is clearly visible to site personnel.

The construction details for the above grade and below grade concrete washout structures can be found on the following web page link:

[http://www.ncdot.gov/doh/operations/dp\\_chief\\_eng/roadside/soil\\_water/details/](http://www.ncdot.gov/doh/operations/dp_chief_eng/roadside/soil_water/details/)

Alternate details for accommodating concrete washout may be submitted for review and approval.

The alternate details shall include the method used to retain and dispose of the concrete waste water within the project limits and in accordance with the minimum setback requirements. (5 feet above groundwater, 50 feet from top of bank of perennial stream, other surface water body, or wetland.)

**Maintenance and Removal**

Maintain the concrete washout structure(s) to provide adequate holding capacity plus a minimum freeboard of 12 inches. Remove and dispose of hardened concrete and return the structure to a functional condition after reaching 75% capacity.

Inspect concrete washout structures for damage and maintain for effectiveness.

Remove the concrete washout structures and sign upon project completion. Grade the earth material to match the existing contours and permanently seed and mulch area.

**Measurement and Payment**

*Concrete Washout Structure* will be paid for per each enclosure installed in accordance with the details. If alternate details are approved then those details will also be paid for per each approved and installed device.

*Temporary Silt Fence* will be measured and paid for in accordance with Article 1605-5 of the *Standard Specifications*.

No measurement will be made for other items or for over excavation or stockpiling.

Payment will be made under:

<b>Pay Item</b>	<b>Pay Unit</b>
Concrete Washout Structure	Each

**CONSTRUCTED RIFFLE:**

**Description**

This work consists of the construction and maintenance of physical barriers placed in and along the stream at locations designated on the plans to provide grade control.

The quantity of constructed riffles to be installed will be affected by the actual conditions that occur during the construction of the project. The quantity of constructed riffles may be increased,

decreased, or eliminated entirely as directed. Such variations in quantity will not be considered as alterations in the details of construction or a change in the character of the work.

### **Materials**

<b>Item</b>	<b>Section</b>
Boulder	1042 and SP for Structure Stone
No. 57 Stone	Section 1005
Riprap, Class A and B	Section 1042-1
Geotextile for Drainage, Type 2	1056

### **Construction Methods**

Constructed riffles shall be constructed according to the Constructed Riffle Detail shown on the plans or as directed.

### **Measurement and Payment**

*Boulders* will be measured and paid for as provided elsewhere in this contract.

*No. 57 Stone* will be measured and paid for as provided elsewhere in this contract.

*Riprap, Class \_\_* will be measured and paid for in accordance with Article 876-4 of the *Standard Specifications*.

*Geotextile for Drainage* will be measured and paid for in accordance with Article 876-4 of the *Standard Specifications*.

Such price and payment will be full compensation for all work covered by this section, including, but not limited to, furnishing all materials, labor, equipment and incidentals necessary to construct the constructed riffles.

### **STRUCTURE STONE:**

#### **Description**

This work consists of furnishing, stockpiling, placing and maintaining approved stone used to construct rock cross-vanes, rock vanes, j-hook vanes, w-rock cross vanes, log vanes, root wad/log vanes, log cross vanes, root wad structures, rock cross vanes for step pools, channel blocks, double wing deflectors, single wing deflectors, stream crossings, rock energy dissipaters, constructed riffles, and for use in other locations as directed.

The quantity of stone to be installed will be affected by the actual conditions that occur during the construction of the project. The quantity of stone may be increased, decreased, or eliminated entirely as directed. Such variations in quantity will not be considered as alterations in the details of construction or a change in the character of the work.

**Materials**

Refer to Division 10

<b>Item</b>	<b>Section</b>
No. 57 Stone	1005
Riprap, Class A, B, 1, and 2	1042
Geotextile for Drainage, Type 2	1056

Boulders shall meet the requirements of Section 1042 of the *Standard Specifications*. Boulders of minimum dimension 36" x 30" x 24" shall be individually picked for use in the structures. Boulders shall be relatively flat on either side in the same dimension, preferably the long dimension.

**Construction Methods**

The Contractor shall place geotextile and stone in locations and to the thickness, widths, and lengths as shown on the plans or as directed. All stone shall be placed to form a sediment and erosion control device, an in-stream structure, or a channel lining neatly and uniformly with an even surface in accordance with the contract and shall meet the approval of the Engineer.

**Measurement and Payment**

*No. 57 Stone* will be measured and paid as the actual number of tons that have been incorporated into the work, or have been delivered to and stockpiled on the project as directed. *No. 57 stone* that has been stockpiled will not be measured a second time.

*Riprap, Class \_\_* will be measured and paid for in accordance with Article 876-4 of the *Standard Specifications*.

*Geotextile for Drainage* will be measured and paid for in accordance with Article 876-4 of the *Standard Specifications*.

*Boulders* will be measured and paid for as the actual number of tons that have been incorporated into the work, or have been delivered to and stockpiled on the project as directed. Stone that has been stockpiled will not be measured a second time.

Such price and payment will be full compensation for all work covered by this section, including but not limited to furnishing, weighing, stockpiling, re-handling, placing, and maintaining the stone and disposal of any materials not incorporated into the project.



Payment will be made under:

**Pay Item**

No. 57 Stone  
Boulder

**Pay Unit**

Ton  
Ton

U-2579C

Signals and Intelligent Transportation Systems  
Project Special Provisions  
(Version 12.5)

Prepared By: IOU  
5-Jun-17

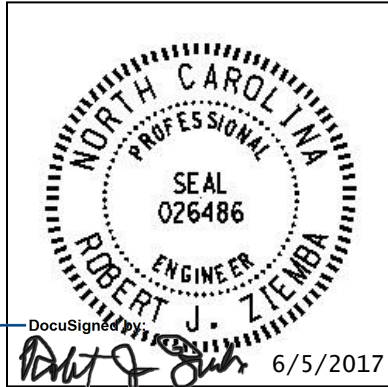

DOCUMENT NOT CONSIDERED FINAL  
UNLESS ALL SIGNATURES COMPLETED

Contents

- 1. GENERAL PROJECT INFORMATION .....2
- 2. 2012 STANDARD SPECIFICATIONS FOR ROADS & STRUCTURES.....2
  - 2.1. POLYMER CONCRETE (PC) JUNCTION BOXES (1091-5(B)).....2
  - 2.2. SUBMITTAL REQUIREMENTS (1098-1(B)) .....2
  - 2.3. JUNCTION BOXES (1098-5).....2
  - 2.4. CONTROLLERS WITH CABINETS – MATERIAL (1751-2) .....3
- 3. SIGNAL HEADS.....3
  - 3.1. MATERIALS .....3
    - A. General:.....3
    - B. Vehicle Signal Heads:.....4
    - C. Signal Cable: .....6
- 4. TRAFFIC SIGNAL SUPPORTS.....7
  - 4.1. METAL TRAFFIC SIGNAL SUPPORTS – ALL POLES .....7
    - A. General:.....7
    - B. Materials: .....9
    - C. Construction Methods: .....10
  - 4.2. METAL POLE UPRIGHTS (VERTICAL MEMBERS) .....10
    - A. Materials: .....10
    - B. Construction Methods: .....12
  - 4.3. DRILLED PIER FOUNDATIONS FOR METAL TRAFFIC SIGNAL POLES .....12
    - A. Description: .....13
    - B. Soil Test and Foundation Determination: .....13
    - C. Drilled Pier Construction: .....15
  - 4.4. CUSTOM DESIGN OF TRAFFIC SIGNAL SUPPORTS .....15
    - A. General:.....15
    - B. Metal Poles:.....16
  - 4.5. POLE NUMBERING SYSTEM .....19
  - 4.6. MEASUREMENT AND PAYMENT .....19
- 5. CONTROLLERS WITH CABINETS .....19
  - 5.1. MATERIALS – TYPE 2070L CONTROLLERS .....19
  - 5.2. MATERIALS – GENERAL CABINETS .....20
  - 5.3. MATERIALS – TYPE 170E CABINETS .....21
    - A. Type 170 E Cabinets General:.....21
    - B. Type 170 E Cabinet Electrical Requirements:.....21
    - C. Type 170 E Cabinet Physical Requirements:.....27
    - D. Model 2018 Enhanced Conflict Monitor: .....28
  - 5.4. MATERIALS – TYPE 170 DETECTOR SENSOR UNITS .....38
  - 5.5. MATERIALS – TYPE 2070E CONTROLLERS .....38

## 1. GENERAL PROJECT INFORMATION

These traffic signals were designed and intended for installation under TIP U-2579C. Per the direction of the Regional Traffic Engineer and the Division 9 Traffic Engineer, these signals shall not be installed and made operational in the field until traffic volumes increase to meet warrants. The warrants for installation shall be approved by the Regional Traffic Engineer prior to any signal construction.

All equipment for these traffic signals shall be provided by the Contactor for U-2579C unless otherwise listed in the project contract or specifications. If the installation for one or more of these traffic signals is not warranted prior to the completion of construction for U-2579C, all signal equipment for these signals will be delivered to the Division 9 Traffic Services office unless otherwise directed by the Engineer. All approved signal equipment will become property of NCDOT and be the responsibility of Division 9 Traffic Services. If the signals are not installed prior to the completion of project U-2579C, Division 9 Traffic Services will be responsible for signal installation upon approval by the Regional Traffic Engineer.

## 2. 2012 STANDARD SPECIFICATIONS FOR ROADS & STRUCTURES

*The 2012 Standard Specifications are revised as follows:*

### 2.1. Polymer Concrete (PC) Junction Boxes (1091-5(B))

Page 10-202, revise paragraph starting on line 9 to read "Provide polymer concrete (PC) boxes which have bolted covers and open bottoms. Provide vertical extensions of 6" to 12" as required by project special provisions."

Page 10-202, revise sentence beginning on line 14 to read "Other thermoplastic materials may be used for components which are not normally exposed to sunlight."

### 2.2. Submittal Requirements (1098-1(B))

Page 10-208, replace paragraph on line 34 with the following:

Submit for approval catalog cuts and/or shop drawings for materials proposed for use on the project. Allow 40 days for review of each submittal. Do not fabricate or order material until receipt of Engineer's approval.

Submit 4 copies of each catalog cut and/or drawing and show for each component the material description, brand name, stock-number, size, rating, manufacturing specification and the intended use (identified by labeling all components with the corresponding contract line item number). Present the submittals neatly arranged in the same order as the contract bid items. Electronic submittals of catalog cuts and drawings may be accepted in lieu of hard copies.

One hard copy and an electronic (PDF) copy of reviewed submittals will be returned to the Engineer from the ITS and Signals Unit.

### 2.3. Junction Boxes (1098-5)

Page 10-212, sub-Section 1098-5(C) Oversized Junction Boxes

Revise sentence to read, "Provide oversized junction boxes and covers with minimum inside dimensions of 28"(l) x 15"(w) x 22"(h)."

**2.4. Controllers with Cabinets – Material (1751-2)**

Page 17-37, Section 1751-2 Material

Add the following paragraph:

When the plans or specifications require a Type 2070L controller, contractor may provide a Type 2070E controller. Unless otherwise allowed by the Engineer, provide controllers of only one type.

**3. SIGNAL HEADS**

**3.1. MATERIALS**

**A. General:**

Fabricate vehicle signal head housings and end caps from die-cast aluminum. Provide visor mounting screws, door latches, and hinge pins fabricated from stainless steel. Provide interior screws, fasteners, and metal parts fabricated from stainless steel.

Fabricate tunnel and traditional visors from sheet aluminum.

Paint all surfaces inside and outside of signal housings and doors. Paint outside surfaces of tunnel and traditional visors, wire outlet bodies, wire entrance fitting brackets and end caps when supplied as components of messenger cable mounting assemblies, pole and pedestal mounting assemblies, and pedestrian pushbutton housings. Have electrostatically-applied, fused-polyester paint in highway yellow (Federal Standard 595C, Color Chip Number 13538) a minimum of 2.5 to 3.5 mils thick. Do not apply paint to the latching hardware, rigid vehicle signal head mounting brackets for mast-arm attachments, messenger cable hanger components or balance adjuster components.

Have the interior surfaces of tunnel and traditional visors painted an alkyd urea black synthetic baking enamel with a minimum gloss reflectance and meeting the requirements of MIL-E-10169, “Enamel Heat Resisting, Instrument Black.”

Where required, provide polycarbonate signal heads and visors that comply with the provisions pertaining to the aluminum signal heads listed on the QPL with the following exceptions:

Fabricate signal head housings, end caps, and visors from virgin polycarbonate material. Provide UV stabilized polycarbonate plastic with a minimum thickness of 0.1 ± 0.01 inches that is highway yellow (Federal Standard 595C, Color Chip 13538). Ensure the color is incorporated into the plastic material before molding the signal head housings and end caps. Ensure the plastic formulation provides the following physical properties in the assembly (tests may be performed on separately molded specimens):

Test	Required	Method
Specific Gravity	1.17 minimum	ASTM D 792
Flammability	Self-extinguishing	ASTM D 635
Tensile Strength, yield, PSI	8500 minimum	ASTM D 638
Izod impact strength, ft-lb/in [notched, 1/8 inch]	12 minimum	ASTM D 256

For light emitting diode (LED) traffic signal modules, provide the following requirements for inclusion on the Department’s Qualified Products List for traffic signal equipment.

1. Sample submittal,

2. Third-party independent laboratory testing results for each submitted module with evidence of testing and conformance with all of the Design Qualification Testing specified in section 6.4 of each of the following Institute of Transportation Engineers (ITE) specifications:
  - Vehicle Traffic Control Signal Heads – Light Emitting Diode (LED) Circular Signal Supplement
  - Vehicle Traffic Control Signal Heads – Light Emitting Diode (LED) Vehicle Arrow Traffic Signal Supplement
  - Pedestrian Traffic Control Signal Indications –Light Emitting Diode (LED) Signal Modules.

(Note: The Department currently recognizes two approved independent testing laboratories. They are Intertek ETL Semko and Light Metrics, Incorporated with Garwood Laboratories. Independent laboratory tests from other laboratories may be considered as part of the QPL submittal at the discretion of the Department,

3. Evidence of conformance with the requirements of these specifications,
4. A manufacturer’s warranty statement in accordance with the required warranty, and
5. Submittal of manufacturer’s design and production documentation for the model, including but not limited to, electrical schematics, electronic component values, proprietary part numbers, bill of materials, and production electrical and photometric test parameters.
6. Evidence of approval of the product to bear the Intertek ETL Verified product label for LED traffic signal modules.

In addition to meeting the performance requirements for the minimum period of 60 months, provide a written warranty against defects in materials and workmanship for the modules for a period of 60 months after installation of the modules. During the warranty period, the manufacturer must provide new replacement modules within 45 days of receipt of modules that have failed at no cost to the State. Repaired or refurbished modules may not be used to fulfill the manufacturer’s warranty obligations. Provide manufacturer’s warranty documentation to the Department during evaluation of product for inclusion on Qualified Products List (QPL).

#### **B. Vehicle Signal Heads:**

Comply with the ITE standard “Vehicle Traffic Control Signal Heads”. Provide housings with provisions for attaching backplates.

Provide visors that are 10 inches in length for 12-inch vehicle signal heads.

Provide a termination block with one empty terminal for field wiring for each indication plus one empty terminal for the neutral conductor. Have all signal sections wired to the termination block. Provide barriers between the terminals that have terminal screws with a minimum Number 8 thread size and that will accommodate and secure spade lugs sized for a Number 10 terminal screw.

Mount termination blocks in the yellow signal head sections on all in-line vehicle signal heads. Mount the termination block in the red section on five-section vehicle signal heads.

Furnish vehicle signal head interconnecting brackets. Provide one-piece aluminum brackets less than 4.5 inches in height and with no threaded pipe connections. Provide hand holes on the bottom

of the brackets to aid in installing wires to the signal heads. Lower brackets that carry no wires and are used only for connecting the bottom signal sections together may be flat in construction.

For messenger cable mounting, provide messenger cable hangers, wire outlet bodies, balance adjusters, bottom caps, wire entrance fitting brackets, and all other hardware necessary to make complete, watertight connections of the vehicle signal heads to the messenger cable. Fabricate messenger cable hanger components, wire outlet bodies and balance adjuster components from stainless steel or malleable iron galvanized in accordance with ASTM A153 (Class A) or ASTM A123. Provide serrated rings made of aluminum. Provide messenger cable hangers with U-bolt clamps. Fabricate washers, screws, hex-head bolts and associated nuts, clevis pins, cotter pins, U-bolt clamps and nuts from stainless steel.

Provide LED vehicular traffic signal modules (hereafter referred to as modules) that consist of an assembly that uses LEDs as the light source in lieu of an incandescent lamp for use in traffic signal sections. Use LEDs that are aluminum indium gallium phosphorus (AlInGaP) technology for red and yellow indications and indium gallium nitride (InGaN) for green indications. Install the ultra bright type LEDs that are rated for 100,000 hours of continuous operation from -40°F to +165°F. Design modules to have a minimum useful life of 60 months and to meet all parameters of this specification during this period of useful life.

For the modules, provide spade terminals crimped to the lead wires and sized for a #10 screw connection to the existing terminal block in a standard signal head. Do not provide other types of crimped terminals with a spade adapter.

Ensure the power supply is integral to the module assembly. On the back of the module, permanently mark the date of manufacture (month & year) or some other method of identifying date of manufacture.

Tint the red, yellow and green lenses to correspond with the wavelength (chromaticity) of the LED. Transparent tinting films are unacceptable. Provide a lens that is integral to the unit with a smooth outer surface.

### **1. LED Circular Signal Modules:**

Provide modules in the following configurations: 12-inch circular sections. All makes and models of LED modules purchased for use on the State Highway System shall appear on the current NCDOT Traffic Signal Qualified Products List (QPL).

Provide the manufacturer's model number and the product number (assigned by the Department) for each module that appears on the 2012 or most recent Qualified Products List. In addition, provide manufacturer's certification in accordance with Article 106-3 of the *Standard Specifications*, that each module meets or exceeds the ITE "Vehicle Traffic Control Signal Heads – Light Emitting Diode (LED) Circular Signal Supplement" dated June 27, 2005 (hereafter referred to as VTCSH Circular Supplement) and other requirements stated in this specification.

Provide modules that meet the following requirements when tested under the procedures outlined in the VTCSH Circular Supplement:

Module Type	Max. Wattage at 165° F	Nominal Wattage at 77° F
12-inch red circular	17	11
12-inch green circular	15	15

For yellow circular signal modules, provide modules tested under the procedures outlined in the VTCSH Circular Supplement to insure power required at 77° F is 22 Watts or less for the 12-inch circular module.

Note: Use a wattmeter having an accuracy of  $\pm 1\%$  to measure the nominal wattage and maximum wattage of a circular traffic signal module. Power may also be derived from voltage, current and power factor measurements.

## 2. LED Arrow Signal Modules

Provide 12-inch omnidirectional arrow signal modules. All makes and models of LED modules purchased for use on the State Highway System shall appear on the current NCDOT Traffic Signal Qualified Products List (QPL).

Provide the manufacturer's model number and the product number (assigned by the Department) for each module that appears on the 2012 or most recent Qualified Products List. In addition, provide manufacturer's certification in accordance with Article 106-3 of the *Standard Specifications*, that each module meets or exceeds the requirements for 12-inch omnidirectional modules specified in the ITE "Vehicle Traffic Control Signal Heads – Light Emitting Diode (LED) Vehicle Arrow Traffic Signal Supplement" dated July 1, 2007 (hereafter referred to as VTCSH Arrow Supplement) and other requirements stated in this specification.

Provide modules that meet the following requirements when tested under the procedures outlined in the VTCSH Arrow Supplement:

Module Type	Max. Wattage at 165° F	Nominal Wattage at 77° F
12-inch red arrow	12	9
12-inch green arrow	11	11

For yellow arrow signal modules, provide modules tested under the procedures outlined in the VTCSH Arrow Supplement to insure power required at 77° F is 12 Watts or less.

Note: Use a wattmeter having an accuracy of  $\pm 1\%$  to measure the nominal wattage and maximum wattage of an arrow traffic signal module. Power may also be derived from voltage, current and power factor measurements.

## C. Signal Cable:

Furnish 16-4 and 16-7 signal cable that complies with IMSA specification 20-1 except provide the following conductor insulation colors:

- For 16-4 cable: white, yellow, red, and green
- For 16-7 cable: white, yellow, red, green, yellow with black stripe tracer, red with black stripe tracer, and green with black stripe tracer. Apply continuous stripe tracer on conductor insulation with a longitudinal or spiral pattern.

Provide a ripcord to allow the cable jacket to be opened without using a cutter. IMSA specification 19-1 will not be acceptable. Provide a cable jacket labeled with the IMSA specification number and provide conductors constructed of stranded copper.

4. TRAFFIC SIGNAL SUPPORTS

4.1. METAL TRAFFIC SIGNAL SUPPORTS – ALL POLES

A. General:

Furnish and install metal strain poles, grounding systems, and all necessary hardware. The work covered by this special provision includes requirements for the design, fabrication, and installation of both standard and custom/site specifically designed metal traffic signal supports and associated foundations.

Provide metal traffic signal support systems that contain no guy assemblies, struts, or stay braces. Provide designs of completed assemblies with hardware that equals or exceeds AASHTO *Standard Specifications for Structural Supports for Highway Signs, Luminaires and Traffic Signals* 6<sup>th</sup> Edition, 2013 (hereafter called 6<sup>th</sup> Edition AASHTO), including the latest interim specifications. Provide assemblies with a round or near-round (18 sides or more) cross-section, or a multi sided cross section with no less than six sides. The sides may be straight, convex, or concave.

Pole heights shown on signal plans are estimated from available data for bid purposes. Prior to furnishing metal signal poles, use field measurements and adjusted cross-sections to determine whether pole heights are sufficient to obtain required clearances. If pole heights are not sufficient, the Contractor should immediately notify the Engineer of the required revised pole heights.

Ensure that metal signal poles permit cables to be installed inside poles and any required mast arms. For holes in the poles and arms used to accommodate cables, provide full-circumference grommets. Arm flange plate wire access holes should be deburred, non grommited, and oversized to fit around the 2” diameter grommited shaft flange plate wire access hole.

After fabrication, have steel poles, required mast arms, and all parts used in the assembly hot-dip galvanized per section 1076. Design structural assemblies with weep holes large enough and properly located to drain molten zinc during the galvanization process. Provide hot-dip galvanizing on structures that meets or exceeds ASTM Standard A-123. Provide galvanizing on hardware that meets or exceeds ASTM Standard A-153. Ensure that threaded material is brushed and retapped as necessary after galvanizing. Perform repair of damaged galvanizing that complies with the following:

Repair of Galvanizing .....Article 1076-7

Standard Drawings for Metal Poles are available that supplement these project special provisions. These drawings are located on the Department’s website:

<https://connect.ncdot.gov/resources/safety/pages/ITS-Design-Resources.aspx>

Comply with article 1098-1B of the *2012 STANDARD SPECIFICATIONS FOR ROADS & STRUCTURES*, hereinafter referred to as the *Standard Specifications* for submittal requirements. Furnish shop drawings for approval. Provide the copies of detailed shop drawings for each type of structure as summarized below. Ensure that shop drawings include material specifications for each component and identify welds by type and size on the detail drawing only, not in table format. **Do not release structures for fabrication until shop drawings have been approved by NCDOT.** Provide an itemized bill of materials for all structural components and associated connecting hardware on the drawings.

Comply with article 1098-1A of the *Standard Specifications* for Qualified Products List (QPL) submittals. All shop drawings must include project location description, signal inventory number(s) and a project number or work order number on the drawings.



Summary of information required for metal pole review submittal:

Item	Hardcopy Submittal	Electronic Submittal	Comments / Special Instructions
Sealed, Approved Signal Plan/Loading Diagram	1	1	All structure design information needs to reflect the latest approved signal plans
Custom Pole Shop Drawings	4 sets	1 set	Show NCDOT inventory number(s), contractor's name and relevant revision number in the title block. All drawings must have a unique <u>drawing</u> number for each project and identified for multiple pages.
Standard Pole Shop Drawings (from the QPL)	4 sets	1 set	Submit drawings on 11" x 17" format media. Show NCDOT inventory number(s), contractor's name and relevant revision number in the title block. All drawings must have a <u>unique drawing</u> number for each project and identified for multiple pages.
Structure Calculations	1 set	1 set	Not required for Standard QPL Poles
Standard Pole Foundation Drawings	1 set	1 set	Submit drawings on 11" x 17" format media. Submit a completed Standard Foundation Selection form for each pole using foundation table on Metal Pole Drawing M-8.
Custom Foundation Drawings	4 sets	1 set	Submit drawings on 11" x 17" format media. Show NCDOT inventory number(s), contractor's name and relevant revision number in the title block. All drawings must have a <u>unique drawing</u> number for each project and identified for multiple pages.  If QPL Poles are used, include the corresponding QPL pole shop drawings with this submittal.
Foundation Calculations	1	1	<b>Submit copies of LPILE input, output and pile tip deflection graph per Section 11.4 of this specification for each foundation.</b>  Not required for Standard QPL Poles
Soil Boring Logs and Report	1	1	Report should include a location plan and a soil classification report including soil capacity, water level, hammer efficiency, soil bearing pressure, soil density, etc. for each pole.

**NOTE** – All shop drawings and custom foundation design drawings must be sealed by a Professional Engineer licensed in the state of North Carolina. All geotechnical information must be sealed by either a Professional Engineer or geologist licensed in the state of North Carolina. Include a title block and revision block on the shop drawings and foundation drawings showing the NCDOT inventory number.

**Shop drawings and foundation drawings may be submitted together or separately for approval. However, shop drawings must be approved before foundations can be reviewed.** Foundation designs will be returned without review if the associated shop drawing has not been approved. Boring reports should include the following: Engineer's summary, boring location maps, soil classification per AASHTO Classification System, hammer efficiency, and Metal Pole Standard Foundation Selection Form. Incomplete submittals will be returned without review. The Reviewer has the right to request additional analysis and copies of the calculations to expedite the approval process.

#### **B. Materials:**

Fabricate metal pole shaft from coil or plate steel to meet the requirements of ASTM A 595 Grade A tubes. For structural steel shapes, plates and bars use A572 Gr 50 min or ASTM A709 Gr 50 min. Provide pole shafts that are round in cross section or multisided tubular shapes and have a uniform linear taper of 0.14 in/ft. Construct shafts from one piece of single ply plate or coil so there are no circumferential weld splices. Galvanize in accordance with AASHTO M 111 or an approved equivalent.

Use the submerged arc process or other NCDOT previously approved process suitable for pole shaft and arms to continuously weld pole shafts and arm shafts along their entire length. The longitudinal seam weld will be finished flush to the outside contour of the base metal. Ensure shafts have no circumferential welds except at the lower end joining the shaft to the pole base and arm base. Use full penetration groove welds with backing ring for all tube-to-transverse-plate connections in accordance with 6<sup>th</sup> Edition AASHTO. Provide welding that conforms to Article 1072-18 of the *Standard Specifications*, except that no field welding on any part of the pole will be permitted unless approved by a qualified engineer.

Refer to Metal Pole Standard Drawing Sheets M2 through M5 for fabrication details. Fabricate anchor bases and mast arm connecting plates from plate steel meeting, as a minimum, the requirements of ASTM A572 Gr 50, AASHTO M270 Gr 50, ASTM A709 Gr50, or an approved equivalent. Conform to the applicable bolt pattern and orientation as shown on Metal Pole Standard Drawing Sheet M2.

Ensure all hardware is galvanized steel or stainless steel. The Contractor is responsible for ensuring that the designer/fabricator specifies connecting hardware and/or materials that do not create a dissimilar metal corrosive reaction.

Provide a minimum of four (4) 1-1/2" diameter high strength bolts for connection between arm plate and pole plate. Increase number of bolts to six (6) 1-1/2" diameter high strength bolts when arm lengths are greater than 50'-0" long.

Unless otherwise required by the design, ensure each anchor rod is 2" diameter and 60" length. Provide 10" minimum thread projection at the top of the rod, and 8" minimum at the bottom of the rod. Use anchor rod assembly and drilled pier foundation materials that meet the *Foundations and Anchor Rod Assemblies for Metal Poles* provision.

For each structural bolt and other steel hardware, hot dip galvanizing shall conform to the requirements of AASHTO M 232 (ASTM A 153). Ensure end caps for poles or mast arms are constructed of cast aluminum conforming to Aluminum Alloy 356.0F.

Provide a circular anchor bolt lock plate that will be secured to the anchor bolts at the embedded end with 2 washers and 2 nuts. Provide a base plate template that matches the bolt circle diameter of

the anchor bolt lock plate. Construct plates and templates from ¼" minimum thick steel with a minimum width of 4". Galvanizing is not required for both plates.

Provide 4 heavy hex nuts and 4 flat washers for each anchor bolt. For nuts, use AASHTO M291 grade 2H, DH, or DH3 or equivalent material. For flat washers, use AASHTO M293 or equivalent material.

### **C. Construction Methods:**

Erect signal support poles only after concrete has attained a minimum allowable compressive strength of 3000 psi. Install anchor rod assemblies in accordance with the *Foundations and Anchor Rod Assemblies for Metal Poles* provision.

For further construction methods, see construction methods for Metal Strain Pole.

Connect poles to grounding electrodes and bond them to the electrical service grounding electrodes.

For holes in the poles used to accommodate cables, install grommets before wiring pole or arm. Do not cut or split grommets.

Attach the terminal compartment cover to the pole by a sturdy chain or cable. Ensure the chain or cable is long enough to permit the cover to hang clear of the compartment opening when the cover is removed, and is strong enough to prevent vandalism. Ensure the chain or cable will not interfere with service to the cables in the pole base.

Attach cap to pole with a sturdy chain or cable. Ensure the chain or cable is long enough to permit the cap to hang clear of the opening when the cap is removed.

Perform repair of damaged galvanizing that complies with the *Standard Specifications*, Article 1076-7 "Repair of Galvanizing."

Install galvanized wire mesh around the perimeter of the base plate to cover the gap between the base plate and top of foundation for debris and pest control.

Install a ¼" thick plate for concrete foundation tag to include: concrete grade, depth, diameter, and reinforcement sizes of the installed foundation.

## **4.2. METAL POLE UPRIGHTS (VERTICAL MEMBERS)**

### **A. Materials:**

- Provide tapered tubular shafts and fabricated of steel conforming to ASTM A-595 Grade A or an approved equivalent.
- Hot-dip galvanize poles in accordance with AASHTO M 111 or an approved equivalent.
- Have shafts that are continuously welded for the entire length by the submerged arc process, and with exposed welds ground or rolled smooth and flush with the base metal. Provide welding that conforms to Article 1072-18 of the *Standard Specification* except that no field welding on any part of the pole will be permitted.
- Have Shafts with no circumferential welds except at the lower end joining the shaft to the base.

- Have anchor bases for steel poles fabricated from plate steel meeting as a minimum the requirements of ASTM A572 Gr 50, AASHTO M270 Gr 50, ASTM A709 Gr 50, or an approved equivalent.

Provide a grounding lug(s) in the approximate vicinity of the messenger cable clamp for bonding and grounding messenger cable. Lugs must accept #4 or #6 AWG wire to bond messenger cables to the pole in order to provide an effective ground fault circuit path. Refer to Metal Pole Standard Drawing Sheet M6 for construction details.

Have poles permanently stamped above the hand holes with the identification tag details as shown on Metal Pole Standard Drawing Sheet M2.

Provide liquid tight flexible metal conduit (Type LFMC), liquid tight flexible nonmetallic conduit (Type LFNC), high density polyethylene conduit (Type HDPE), or approved equivalent to isolate conductors feeding luminaires.

Fabricate poles from a single piece of steel or aluminum with single line seam weld with no transverse butt welds. Fabrication of two ply pole shafts is unacceptable with the exception of fluted shafts. Provide tapers for all shafts that begin at base and that have diameters which decrease uniformly at the rate of not more than 0.14 inch per foot (11.7 millimeters per meter) of length.

Provide four anchor nuts and four washers for each anchor bolt. Ensure that anchor bolts have required diameters, lengths, and positions, and will develop strengths comparable to their respective poles.

Provide a terminal compartment with cover and screws in each pole that encompasses the hand hole and contains a 12-terminal barrier type terminal block. Provide two terminal screws with a removable shorting bar between them for each termination. Furnish terminal compartment covers attached to the pole by a sturdy chain or cable approved by the Engineer. Ensure that the chain or cable is long enough to permit the cover to hang clear of the compartment opening when the cover is removed, and is strong enough to prevent vandals from being able to disconnect the cover from the pole. Ensure that the chain or cable will not interfere with service to the cables in the pole base.

Install grounding lugs that will accept #4 or #6 AWG wire to electrically bond messenger cables to the pole. Refer to Metal Pole Standard Drawing Sheet M6 for construction details.

For each pole, provide a 1/2 inch minimum thread diameter, coarse thread stud and nut for grounding which will accommodate #6 AWG ground wire. Ensure that the lug is electrically bonded to the pole and is conveniently located inside the pole at the hand hole.

Provide a removable pole cap with stainless steel attachment screws for the top of each pole. Ensure that the cap is cast aluminum conforming to Aluminum Association Alloy 356.0F. Furnish cap attached to the pole with a sturdy chain or cable approved by the Engineer. Ensure that the chain or cable is long enough to permit the cap to hang clear of the pole-top opening when the cap is removed.

When required by the plans, furnish couplings 42 inches above the bottom of the base for mounting of pedestrian pushbuttons. Provide mounting points consisting of 1-1/2 inch internally threaded half-couplings that comply with the NEC and that are mounted within the poles. Ensure that couplings are essentially flush with the outside surfaces of the poles and are installed before any required galvanizing. Provide a threaded plug in each mounting point. Ensure that the surface of the plug is essentially flush with the outer end of the mounting point when installed and has a recessed hole to accommodate a standard wrench.

## 1. STRAIN POLE SHAFTS

Provide 2 messenger cable (span wire) clamps and associated hardware for attachment of messenger cable. Ensure that diameter of the clamp is appropriate to its location on the pole and is appropriately designed to be adjustable from 1'-6" below the top, down to 6'-6" below the top of the pole. Do not attach more than one support cable to a messenger cable clamp.

Provide a minimum of three (3) 2 inch (50 mm) holes equipped with an associated coupling and weatherhead on the messenger cable load side of the pole to accommodate passage of signal cables from inside the pole. Provide galvanized threaded plugs for all unused couplings at pole entrance points. Refer to Metal Pole Standard Drawing Sheet M3 for fabrication details.

Ensure that allowable pole deflection does not exceed that allowed per 6<sup>th</sup> Edition AASHTO. Ensure maximum deflection at the top of the pole does not exceed 2.5 percent of the pole height.

### B. Construction Methods:

Install metal poles, hardware, and fittings as shown on the manufacturer's installation drawings. Install metal poles so that when the pole is fully loaded it is within 1 degree 40 minutes (1°40') of vertical. Install poles with the manufacturer's recommended "rake." Use threaded leveling nuts to establish rake if required.

#### 4.3. DRILLED PIER FOUNDATIONS FOR METAL TRAFFIC SIGNAL POLES

Analysis procedures and formulas shall be based on AASHTO 6<sup>th</sup> Edition, latest ACI code and the *Drilled Shafts: Construction Procedures and Design Methods* FHWA-NHI-10-016 manual. Design methods based on engineering publications or research papers needs to have prior approval from NCDOT. The Department reserves the right to accept or disapprove any method used for the analysis.

Use a Factor of Safety of 1.33 for torsion and 2.0 for bending for the foundation design.

Foundation design for lateral load shall not exceed 1" lateral deflection at top of foundation.

For lateral analysis, use LPILE Plus V6.0 or later. Inputs, results and corresponding graphs are to be submitted with the design calculations.

Skin Friction is to be calculated using the  $\alpha$ -method for cohesive soils and the  $\beta$ -method for cohesion-less soils (**Broms method will not be accepted**). Detailed descriptions of the " $\alpha$ " and " $\beta$ " methods can be found in *FHWA-NHI-10-016*.

Omit first 2.5ft for cohesive soils when calculating skin friction.

When hammer efficiency is not provided, assume a value of 0.70.

Design all custom foundations to carry the maximum capacity of each metal pole. For standard case strain poles only, if a custom foundation is designed, use the actual shear, axial and moment reactions from the Standard Foundation Selection Table shown on Standard Drawing No. M8.

When poor soil conditions are encountered which could create an excessively large foundation design, consideration may be given to allowing an exemption to the maximum capacity design. The contractor must gain approval from the engineer before reducing a foundation's capacity. On projects where poor soil is known to be present, it is advisable that the contractor consider getting foundations approved before releasing poles for fabrication.

Have the contractor notify the engineer if the proposed foundation is to be installed on a slope other than 8H: 1V or flatter.

**A. Description:**

Furnish and install foundations for NCDOT metal poles with all necessary hardware in accordance with the plans and specifications.

Metal Pole Standards have been developed and implemented by NCDOT for use at signalized intersections in North Carolina. If the plans call for a standard pole, then a standard foundation may be selected from the plans. However, the Contractor is not required to use a standard foundation. If the Contractor chooses to design a non-standard site-specific foundation for a standard pole or if the plans call for a non-standard site-specific pole, design the foundation to conform to the applicable provisions in the NCDOT Metal Pole Standard Drawings and Section B7 (Non-Standard Foundation Design) below. If non-standard site specific foundations are designed for standard QPL approved strain poles, the foundation designer must use the design moment specified by load case on Metal Pole Standard Drawing Sheet M8. Failure to conform to this requirement will be grounds for rejection of the design.

If the Contractor chooses to design a non-standard foundation for a standard pole and the soil test results indicate a standard foundation is feasible for the site, the Contractor will be paid the cost of the standard foundation (drilled pier and wing wall, if applicable). Any additional costs associated with a non-standard site-specific foundation including additional materials, labor and equipment will be considered incidental to the cost of the standard foundation. All costs for the non-standard foundation design will also be considered incidental to the cost of the standard foundation.

**B. Soil Test and Foundation Determination:**

**1. General:**

Drilled piers are reinforced concrete sections, cast-in-place against in situ, undisturbed material. Drilled piers are of straight shaft type and vertical.

Some standard drilled piers for supporting poles with mast arms may require wing walls to resist torsional rotation. Based upon this provision and the results of the required soil test, a drilled pier length and wing wall requirement may be determined and constructed in accordance with the plans.

For non-standard site-specific poles, the contractor-selected pole fabricator will determine if the addition of wing walls is necessary for the supporting foundations.

**2. Soil Test:**

Perform a soil test at each proposed metal pole location. Complete all required fill placement and excavation at each signal pole location to finished grade before drilling each boring. Soil tests performed that are not in compliance with this requirement may be rejected and will not be paid. Drill one boring to a depth of 26 feet within a 25 foot radius of each proposed foundation.

Perform standard penetration tests (SPT) in accordance with ASTM D 1586 at depths of 1, 2.5, 5, 7.5, 10, 15, 20 and 26 feet. Discontinue the boring if one of the following occurs:

- A total of 100 blows have been applied in any 2 consecutive 6-in. intervals.
- A total of 50 blows have been applied with < 3-in. penetration.

Describe each intersection as the “Intersection of (*Route or SR #*), (*Street Name*) and (*Route or SR #*), (*Street Name*), \_\_\_\_\_ County, Signal Inventory No. \_\_\_\_\_”. Label borings with “B- *N, S, E, W, NE, NW, SE or SW*” corresponding to the quadrant location within the intersection. Pole numbers should be made available to the Drill Contractor. Include pole numbers in the boring label if they are available. If they are not available, ensure the boring labels can be cross-referenced to corresponding pole numbers. For each boring, submit a legible (hand written or typed) boring log signed and sealed by a licensed Geologist or Professional Engineer registered in North Carolina. Include on each boring the SPT blow counts and N-values at each depth, depth of the boring, hammer efficiency, depth of water table and a general description of the soil types encountered using the AASHTO Classification System.

**3. Standard Foundation Determination:**

Use the following method for determining the Design N-value:

$$N_{AVG} = \frac{(N@1' + N@2.5' + \dots + N@Deepest \text{ Boring Depth})}{\text{Total Number of N-values}}$$

$$Y = (N@1')^2 + (N@2.5')^2 + \dots + (N@Deepest \text{ Boring Depth})^2$$

$$Z = (N@1' + N@2.5' + \dots + N@Deepest \text{ Boring Depth})$$

$$N_{STD \text{ DEV}} = \left\{ \frac{(\text{Total Number of N-values} \times Y) - Z^2}{(\text{Total Number of N-values}) \times (\text{Total Number of N-values} - 1)} \right\}^{0.5}$$

**Design N-value** equals lesser of the following two conditions:

$$N_{AVG} - (N_{STD \text{ DEV}} \times 0.45)$$

*Or*

$$\text{Average of First Four N-Values} = \frac{(N@1' + N@2.5' + N@5' + N@7.5')}{4}$$

*Note: If less than 4 N-values are obtained because of criteria listed in Section 2 above, use average of N-values collected for second condition. Do not include the N-value at the deepest boring depth for above calculations if the boring is discontinued at or before the required boring depth because of criteria listed in Section 2 above. Use N-value of zero for weight of hammer or weight of rod. If N-value is greater than 50, reduce N-value to 50 for calculations.*

If standard NCDOT strain poles are shown on the plans and the Contractor chooses to use standard foundations, determine a drilled pier length, “L,” for each signal pole from the Standard Foundations Chart (sheet M 8) based on the Design N-value and the predominant soil type. For each standard pole location, submit a completed “Metal Pole Standard Foundation Selection Form” signed by the Contractor’s representative. Signature on form is for verification purposes only. Include the Design N-value calculation and resulting drilled pier length, “L,” on each form.

If non-standard site-specific poles are shown on the plans, submit completed boring logs collected in accordance with Section 2 (Soil Test) above along with pole loading diagrams from the plans to the contractor-selected pole fabricator to assist in the pole and foundation design.

If one of the following occurs, the Standard Foundations Chart shown on the plans may not be used and a non-standard foundation may be required. In such case, contact the Engineer.

- The Design N-value is less than 4.
- The drilled pier length, “L”, determined from the Standard Foundations Chart, is greater than the depth of the corresponding boring.

In the case where a standard foundation cannot be used, the Department will be responsible for the additional cost of the non-standard foundation.

Foundation designs are based on level ground around the traffic signal pole. If the slope around the edge of the drilled pier is steeper than 8:1 (H:V) or the proposed foundation will be less than 10 feet from the top of an embankment slope, the Contractor is responsible for providing slope information to the foundation designer and to the Engineer so it can be considered in the design.

The “Metal Pole Standard Foundation Selection Form” may be found at:

<http://www.ncdot.gov/doh/preconstruct/highway/geotech/formdet/misc/MetalPole.pdf>

If assistance is needed, contact the Engineer.

#### **4. Non-Standard Foundation Design:**

Design non-standard foundations based upon site-specific soil test information collected in accordance with Section 2 (Soil Test) above. Design drilled piers for side resistance only in accordance with Section 4.6 of the *AASHTO Standard Specifications for Highway Bridges*. Use the computer software LPILE version-6.0 or later manufactured by Ensoft, Inc. to analyze drilled piers. Use the computer software gINT V8i or later manufactured by Bentley Systems, Inc. with the current NCDOT gINT library and data template to produce SPT boring logs. Provide a drilled pier foundation for each pole with a length and diameter that result in a horizontal lateral movement of less than 1 inch at the top of the pier and a horizontal rotational movement of less than 1 inch at the edge of the pier. Contact the Engineer for pole loading diagrams for standard poles to be used for non-standard foundation designs. Submit any non-standard foundation designs including drawings, calculations, and soil boring logs to the Engineer for review and approval before construction.

#### **C. Drilled Pier Construction:**

Construct drilled pier foundations in accordance with the *Foundations and Anchor Rod Assemblies for Metal Poles* provision.

#### **4.4. CUSTOM DESIGN OF TRAFFIC SIGNAL SUPPORTS**

##### **A. General:**

Design traffic signal supports with foundations consisting of metal strain poles.

The lengths of the metal signal poles shown on the plans are estimated from available data for bid purposes. Determine the actual length of each pole from field measurements and adjusted cross-sections. Furnish the revised pole heights to the Engineer. Use all other dimensional requirements shown on the plans.



Ensure each pole includes an identification tag with information and location positions as defined on Metal Pole Standard Drawing Sheets M2, M3 and M4. All pole shaft tags must include the NCDOT Inventory number followed by the pole number shown on the traffic signal or ITS (non-signalized locations) plan.

Design all traffic signal support structures using the following 6<sup>th</sup> Edition AASHTO specifications:

- Design for a 50 year service life as recommended by Table 3.8.3-2.
- Use the wind pressure map developed from 3-second gust speeds, as provided in Article 3.8.
- Ensure signal support structures include natural wind gust loading and truck-induced gust loading in the fatigue design, as provided for in Articles 11.7.1.2 and 11.7.1.3, respectively. Designs need not consider periodic galloping forces.
- Assume the natural wind gust speed in North Carolina is 11.2 mph. For natural wind fatigue stress calculations, utilize a drag coefficient ( $C_d$ ) computed for 11.2 mph wind velocity and not the basic wind speed velocity.
- Design for Category II fatigue, as provided for in Article 11.6, unless otherwise specified.
- Calculate all stresses using applicable equations from Section 5. The Maximum allowable stress ratios for all signal support designs are 0.9.
- Conform to article 10.4.2 and 11.8 for all deflection requirements.

Ensure that the design permits cables to be installed inside poles and mast arms.

Unless otherwise specified by special loading criteria, the computed surface area for ice load on signal heads is:

- 3-section, 12-inch, Surface area: 26.0 ft<sup>2</sup> (17.0 ft<sup>2</sup> without back plate)
- 4-section, 12-inch, Surface area: 32.0 ft<sup>2</sup> (21.0 ft<sup>2</sup> without back plate)
- 5-section, 12-inch, Surface area: 42.0 ft<sup>2</sup> (29.0 ft<sup>2</sup> without back plate)

The ice loading for signal heads defined above includes the additional surface area that back plates will induce. Special loading criteria may be specified in instances where back plates will not be installed on signal heads. Refer to the Loading Schedule on each Metal Pole Loading Diagram for revised signal head surface areas. The pole designer should revise ice loads accordingly in this instance. Careful examination of the plans when this is specified is important as this may impact sizing of the metal support structure and foundation design which could affect proposed bid quotes. All maximum stress ratios of 0.9 still apply.

Assume the combined minimum weight of a messenger cable bundle (including messenger cable, signal cable and detector lead-in cables) is 1.3 lbs/ft. Assume the combined minimum diameter of this cable bundle is 1.3 inches.

Ensure that designs provide a removable pole cap with stainless steel attachment screws for each pole top and mast arm end.

## **B. Metal Poles:**

Submit design drawings for approval including pre-approved QPL pole drawings. Show all the necessary details and calculations for the metal poles including the foundation and connections. Include NCDOT inventory number on design drawings. Include as part of the design calculations the

ASTM specification numbers for the materials to be used. Provide the types and sizes of welds on the design drawings. Include a Bill of Materials on design drawings. Ensure design drawings and calculations are signed, dated, and sealed by the responsible professional engineer licensed in the state of North Carolina. Immediately bring to the attention of the Engineer any structural deficiency that becomes apparent in any assembly or member of any assembly as a result of the design requirements imposed by these specifications, the plans, or the typical drawings. Said Professional Engineer is wholly responsible for the design of all poles and arms. Review and acceptance of these designs by the Department does not relieve the said Professional Engineer of his responsibility. **Do not fabricate the assemblies until receipt of the Department's approval of the design drawings.**

For mast arm poles, provide designs with provisions for pole plates and associated gussets and fittings for mast arm attachment. As part of each mast arm attachment, provide a grommeted 2" diameter hole on the shaft side of the connection to allow passage of the signal cables from the pole to the arm.

Where ice is present, assume wind loads as shown in Figure 3.9.4.2-3 of the 6<sup>th</sup> Edition AASHTO Specification for Group III loading.

For each strain pole, provide two messenger cable clamps and associated hardware to attach the messenger support cable. Ensure that the diameter of the clamps is appropriately designed to be adjustable from 1'-6" inches below the top, down to 6'-6" below the top of the pole. Do not attach more than one messenger support cable to a messenger cable clamp.

Provide a grounding lug(s) in the approximate vicinity of the messenger cable clamp for bonding and grounding messenger cable. Lugs must accept #4 or #6 AWG wire to bond messenger cables to the pole in order to provide an effective ground fault circuit path. Refer to Metal Pole Standard Drawing Sheet M6 for construction details.

Design tapers for all pole shafts that begin at the base with diameters that decrease uniformly at the rate of 0.14 inch per foot of length.

Design a base plate on each pole. The minimum base plate thickness for all poles is determined by the following criteria:

Case 1 Circular or rectangular solid base plate with the upright pole welded to the top surface of base plate with full penetration butt weld, and where no stiffeners are provided. A base plate with a small center hole, which is less than 1/3 of the upright diameter, and located concentrically with the upright pole, may be considered as a solid base plate.

The magnitude of bending moment in the base plate, induced by the anchoring force of each anchor bolt is  $M = (P \times D_1) / 2$ , where

M = bending moment at the critical section of the base plate induced by one anchor bolt

P = anchoring force of each anchor bolt

D<sub>1</sub> = horizontal distance between the anchor bolt center and the outer face of the upright, or the difference between the bolt circle radius and the outside radius of the upright

Locate the critical section at the face of the anchor bolt and perpendicular to the bolt circle radius. The overlapped part of two adjacent critical sections is considered ineffective.

Case 2 Circular or rectangular base plate with the upright pole socketed into and attached to the base plate with two lines of fillet weld, and where no stiffeners are provided, or any base plate with a center hole that is larger in diameter than 1/3 of the upright diameter.

The magnitude of bending moment induced by the anchoring force of each anchor bolt is  $M = P \times D_2$ ,

where  $P$  = anchoring force of each anchor bolt

$D_2$  = horizontal distance between the face of the upright and the face of the anchor bolt nut

Locate the critical section at the face of the anchor bolt top nut and perpendicular to the radius of the bolt circle. The overlapped part of two adjacent critical sections is considered ineffective.

If the base plate thickness calculated for Case 2 is less than Case 1, use the thickness calculated for Case 1.

The following additional owner requirements apply concerning pole base plates.

- Ensure that whichever case governs as defined above, the anchor bolt diameter is set to match the base plate thickness. If the minimum diameter required for the anchor bolt exceeds the thickness required for the base plate, set the base plate thickness equal to the required bolt diameter.
- For dual mast arm supports, or for single mast arm supports 50' or greater, use a minimum 8 bolt orientation with 2" diameter anchor bolts, and a 2" thick base plate.
- For all metal poles with mast arms, use a full penetration groove weld with a backing ring to connect the pole upright component to the base. Refer to Metal Pole Standard Drawing Sheet M4.

Ensure that designs have anchor bolt holes with a diameter 1/4 inch larger than the anchor bolt diameters in the base plate.

Ensure that the anchor bolts have the required diameters, lengths, and positions, and will develop strengths comparable to their respective poles.

Provide designs with a 6 x 12-inch hand hole with a reinforcing frame for each pole.

Provide designs with a terminal compartment with cover and screws in each pole that encompasses the hand hole and contains provisions for a 12-terminal barrier type terminal block.

For each pole, provide designs with provisions for a 1/2 inch minimum thread diameter, coarse thread stud and nut for grounding which will accommodate a #6 AWG ground wire. Ensure the lug is electrically bonded to the pole and is conveniently located inside the pole at the hand hole.

When required, design couplings on the pole for mounting pedestrian pushbuttons at a height of 42 inches above the bottom of the base. Provide mounting points consisting of 1-1/2 inch internally threaded half-couplings that comply with the NEC that are mounted within the poles. Ensure the couplings are essentially flush with the outside surfaces of the poles and are installed before any required galvanizing. Provide a threaded plug for each half coupling. Ensure that the surface of the plug is essentially flush with the outer end of the mounting point when installed and has a recessed hole to accommodate a standard wrench.

**4.5. POLE NUMBERING SYSTEM**

Attach an identification tag to each pole shaft and mast arm section as shown on Metal Pole Standard Drawing Sheet M2 “Typical Fabrication Details Common To All Metal Poles”.

**4.6. MEASUREMENT AND PAYMENT**

Actual number of metal strain signal poles (without regard to height or load capacity) furnished, installed and accepted.

Actual number of soil tests with SPT borings drilled furnished and accepted.

Actual volume of concrete poured in cubic yards of drilled pier foundation furnished, installed and accepted.

No measurement will be made for foundation designs prepared with metal pole designs, as these will be considered incidental to designing signal support structures.

**Payment will be made under:**

Metal Strain Signal Pole .....	Each
Soil Test .....	Each
Drilled Pier Foundation.....	Cubic Yard

**5. CONTROLLERS WITH CABINETS**

**5.1. MATERIALS – TYPE 2070L CONTROLLERS**

Conform to CALTRANS *Transportation Electrical Equipment Specifications (TEES)* (dated August 16, 2002, plus Errata 1 dated October 27, 2003 and Errata 2 dated June 08, 2004) except as required herein.

Furnish Model 2070L controllers. Ensure that removal of the CPU module from the controller will place the intersection into flash.

The Department will provide software at the beginning of the burning-in period. Contractor shall give 5 working days notice before needing software. Program software provided by the Department.

Provide model 2070L controllers with the latest version of OS9 operating software and device drivers, composed of the unit chassis and at a minimum the following modules and assemblies:

- MODEL 2070 1B, CPU Module, Single Board
- MODEL 2070-2A, Field I/O Module (FI/O)
  - Note: Configure the Field I/O Module to disable both the External WDT Shunt/Toggle Switch and SP3 (SP3 active indicator is “off”)
- MODEL 2070-3B, Front Panel Module (FP), Display B (8x40)
- MODEL 2070-4A, Power Supply Module, 10 AMP
- MODEL 2070-7A, Async Serial Com Module (9-pin RS-232)

Furnish one additional MODEL 2070-7A, Async Serial Com Module (9-pin RS-232) for all master controller locations.

For each master location and central control center, furnish a U.S. Robotics V.92 or approved equivalent auto-dial/auto-answer external modem to accomplish the interface to the Department-furnished microcomputers. Include all necessary hardware to ensure telecommunications.

## 5.2. MATERIALS – GENERAL CABINETS

Provide a moisture resistant coating on all circuit boards.

Provide one 20 mm diameter radial lead UL-recognized metal oxide varistor (MOV) between each load switch field terminal and equipment ground. Electrical performance is outlined below.

<b>PROPERTIES OF MOV SURGE PROTECTOR</b>	
Maximum Continuous Applied Voltage at 185° F	150 VAC (RMS) 200 VDC
Maximum Peak 8x20µs Current at 185° F	6500 A
Maximum Energy Rating at 185° F	80 J
Voltage Range 1 mA DC Test at 77° F	212-268 V
Max. Clamping Voltage 8x20µs, 100A at 77° F	395 V
Typical Capacitance (1 MHz) at 77° F	1600 pF

Provide a power line surge protector that is a two-stage device that will allow connection of the radio frequency interference filter between the stages of the device. Ensure that a maximum continuous current is at least 10A at 120V. Ensure that the device can withstand a minimum of 20 peak surge current occurrences at 20,000A for an 8x20 microsecond waveform. Provide a maximum clamp voltage of 395V at 20,000A with a nominal series inductance of 200µh. Ensure that the voltage does not exceed 395V. Provide devices that comply with the following:

<b>Frequency (Hz)</b>	<b>Minimum Insertion Loss (dB)</b>
60	0
10,000	30
50,000	55
100,000	50
500,000	50
2,000,000	60
5,000,000	40
10,000,000	20
20,000,000	25

### 5.3. MATERIALS – TYPE 170E CABINETS

#### A. Type 170 E Cabinets General:

Conform to the city of Los Angeles' Specification No. 54-053-08, *Traffic Signal Cabinet Assembly Specification* (dated July 2008), except as required herein.

Furnish model 332 base mounted cabinets configured for 8 vehicle phases, 4 pedestrian phases, and 6 overlaps. When overlaps are required, provide auxiliary output files for the overlaps. Do not reassign load switches to accommodate overlaps unless shown on electrical details.

Provide model 200 load switches, model 222 loop detector sensors, model 252 AC isolators, and model 242 DC isolators according to the electrical details. As a minimum, provide one (1) model 2018 conflict monitor, one (1) model 206L power supply unit, two (2) model 204 flashers, one (1) DC isolator (located in slot I14), and four (4) model 430 flash transfer relays (provide seven (7) model 430 flash transfer relays if auxiliary output file is installed) with each cabinet.

#### B. Type 170 E Cabinet Electrical Requirements:

Provide a cabinet assembly designed to ensure that upon leaving any cabinet switch or conflict monitor initiated flashing operation, the controller starts up in the programmed start up phases and start up interval.

Furnish two sets of non-fading cabinet wiring diagrams and schematics in a paper envelope or container and placed in the cabinet drawer.

All AC+ power is subject to radio frequency signal suppression.

Provide surge suppression in the cabinet for each type of cabinet device. Provide surge protection for the full capacity of the cabinet input file. Provide surge suppression devices that operate properly over a temperature range of -40° F to +185° F. Ensure the surge suppression devices provide both common and differential modes of protection.

Provide a pluggable power line surge protector that is installed on the back of the PDA (power distribution assembly) chassis to filter and absorb power line noise and switching transients. Ensure the device incorporates LEDs for failure indication and provides a dry relay contact closure for the purpose of remote sensing. Ensure the device meets the following specifications:

- Peak Surge Current (Single pulse, 8x20µs).....20,000A
- Occurrences (8x20µs waveform).....10 minimum @ 20,000A
- Maximum Clamp Voltage.....395VAC
- Operating Current.....15 amps
- Response Time.....< 5 nanoseconds

Provide a loop surge suppressor for each set of loop terminals in the cabinet. Ensure the device meets the following specifications:

- Peak Surge Current (6 times, 8x20µs)
  - (Differential Mode).....400A
  - (Common Mode).....1,000A
- Occurrences (8x20µs waveform).....500 min @ 200A

- Maximum Clamp Voltage
  - (Differential Mode @400A).....35V
  - (Common Mode @1,000A).....35V
- Response Time.....< 5 nanoseconds
- Maximum Capacitance.....35 pF

Provide a data communications surge suppressor for each communications line entering or leaving the cabinet. Ensure the device meets the following specifications:

- Peak Surge Current (Single pulse, 8x20 $\mu$ s).....10,000A
- Occurrences (8x20 $\mu$ s waveform).....100 min @ 2,000A
- Maximum Clamp Voltage.....Rated for equipment protected
- Response Time.....< 1 nanosecond
- Maximum Capacitance.....1,500 pF
- Maximum Series Resistance.....15 $\Omega$

Provide a DC signal surge suppressor for each DC input channel in the cabinet. Ensure the device meets the following specifications:

- Peak Surge Current (Single pulse, 8x20 $\mu$ s).....10,000A
- Occurrences (8x20 $\mu$ s waveform).....100 @ 2,000A
- Maximum Clamp Voltage.....30V
- Response Time.....< 1 nanosecond

Provide a 120 VAC signal surge suppressor for each AC+ interconnect signal input. Ensure the device meets the following specifications:

- Peak Surge Current (Single pulse, 8x20 $\mu$ s).....20,000A
- Maximum Clamp Voltage.....350VAC
- Response Time.....< 200 nanoseconds
- Discharge Voltage.....<200 Volts @ 1,000A
- Insulation Resistance..... $\geq$ 100 M $\Omega$

Provide conductors for surge protection wiring that are of sufficient size (ampacity) to withstand maximum overcurrents which could occur before protective device thresholds are attained and current flow is interrupted.

If additional surge protected power outlets are needed to accommodate fiber transceivers, modems, etc., install a UL listed, industrial, heavy-duty type power outlet strip with a minimum rating of 15 A / 125 VAC, 60 Hz. Provide a strip that has a minimum of 3 grounded outlets. Ensure the power outlet strip plugs into one of the controller unit receptacles located on the rear of the PDA. Ensure power outlet strip is mounted securely; provide strain relief if necessary.

Provide a door switch in the front and a door switch in the rear of the cabinet that will provide the controller unit with a Door Ajar alarm when either the front or the rear door is open. Ensure the door switches apply DC ground to the Input File when either the front door or the rear door is open.

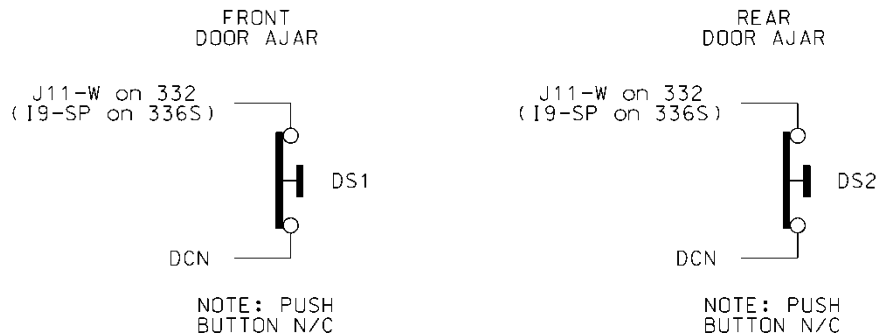

Furnish a fluorescent fixture in the rear across the top of the cabinet and another fluorescent fixture in the front across the top of the cabinet at a minimum. Ensure that the fixtures provide sufficient light to illuminate all terminals, labels, switches, and devices in the cabinet. Conveniently locate the fixtures so as not to interfere with a technician's ability to perform work on any devices or terminals in the cabinet. Provide a protective diffuser to cover exposed bulbs. Install 16 watt T-4 lamps in the fluorescent fixtures. Provide a door switch to provide power to each fixture when the respective door is open. Wire the fluorescent fixtures to the 15 amp ECB (equipment circuit breaker).

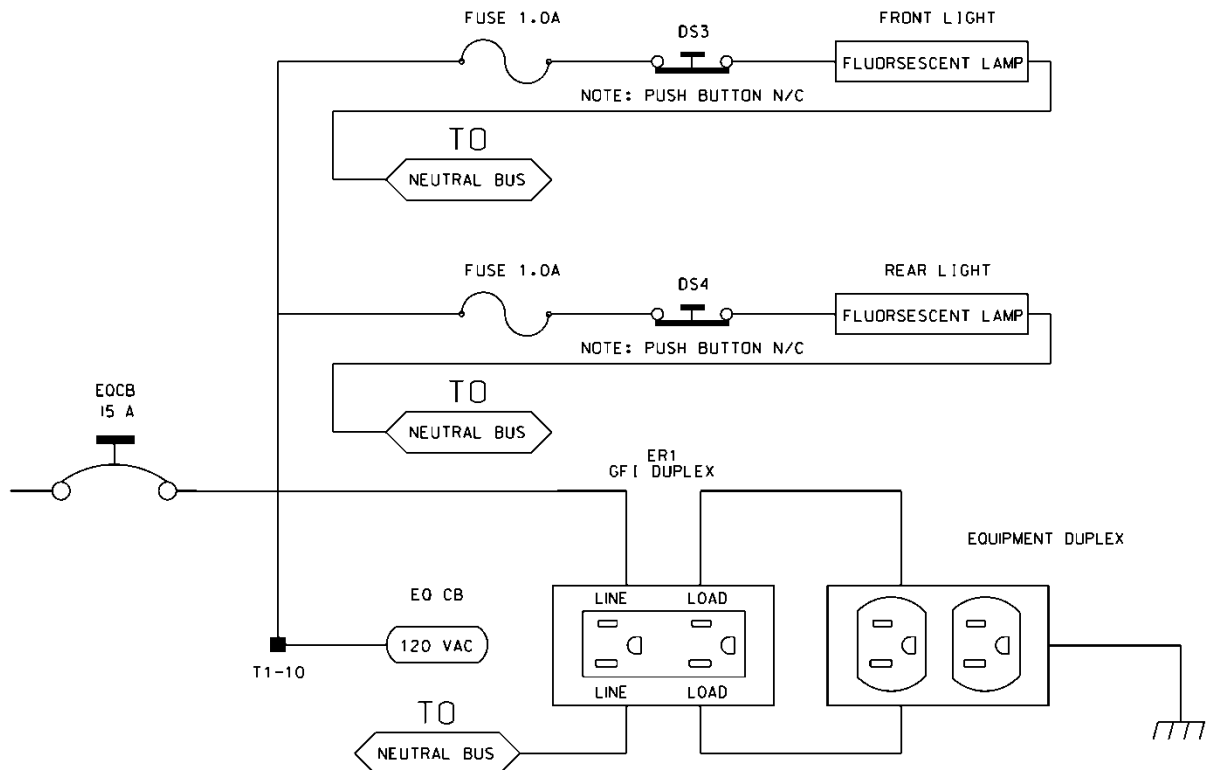



Furnish a police panel with a police panel door. Ensure that the police panel door permits access to the police panel when the main door is closed. Ensure that no rainwater can enter the cabinet even with the police panel door open. Provide a police panel door hinged on the right side as viewed from the front. Provide a police panel door lock that is keyed to a standard police/fire call box key. In addition to the requirements of LA Specification No. 54-053-08, provide the police panel with a toggle switch connected to switch the intersection operation between normal stop-and-go operation (AUTO) and manual operation (MANUAL). Ensure that manual control can be implemented using inputs and software such that the controller provides full programmed clearance times for the yellow clearance and red clearance for each phase while under manual control.

Provide a 1/4-inch locking phone jack in the police panel for a hand control to manually control the intersection. Provide sufficient room in the police panel for storage of a hand control and cord.

For model 332 base mounted cabinets, ensure terminals J14-E and J14-K are wired together on the rear of the Input File. Connect TB9-12 (J14 Common) on the Input Panel to T1-2 (AC-) on the rear of the PDA.

Provide detector test switches mounted at the top of the cabinet rack or other convenient location which may be used to place a call on each of eight phases based on the chart below. Provide three positions for each switch: On (place call), Off (normal detector operation), and Momentary On (place momentary call and return to normal detector operation after switch is released). Ensure that the switches are located such that the technician can read the controller display and observe the intersection.

Connect detector test switches for cabinets as follows:

<b>332 Cabinet</b>	
<b>Detector Call Switches</b>	<b>Terminals</b>
Phase 1	I1-W
Phase 2	I4-W
Phase 3	I5-W
Phase 4	I8-W
Phase 5	J1-W
Phase 6	J4-W
Phase 7	J5-W
Phase 8	J8-W

Provide the PCB 28/56 connector for the conflict monitor unit (CMU) with 28 independent contacts per side, dual-sided with 0.156 inch contact centers. Provide the PCB 28/56 connector contacts with solder eyelet terminations. Ensure all connections to the PCB 28/56 connector are soldered to the solder eyelet terminations.

Ensure that all cabinets have the CMU connector wired according to the 332 cabinet connector pin assignments (include all wires for auxiliary output file connection). Wire pins 13, 16, R, and U of the CMU connector to a separate 4 pin plug, P1, as shown below. Provide a second plug, P2,

which will mate with P1 and is wired to the auxiliary output file as shown below. Provide an additional plug, P3, which will mate with P1 and is wired to the pedestrian yellow circuits as shown below. When no auxiliary output file is installed in the cabinet, provide wires for the green and yellow inputs for channels 11, 12, 17, and 18, the red inputs for channels 17 and 18, and the wires for the P2 plug. Terminate the two-foot wires with ring type lugs, insulated, and bundled for optional use.

	P1		P2		P3	
PIN	FUNCTION	CONN TO	FUNCTION	CONN TO	FUNCTION	CONN TO
1	CH-9G	CMU-13	OLA-GRN	A123	2P-YEL	114
2	CH-9Y	CMU-16	OLA-YEL	A122	4P-YEL	105
3	CH-10G	CMU-R	OLB-GRN	A126	6P-YEL	120
4	CH-10Y	CMU-U	OLB-YEL	A125	8P-YEL	111

Do not provide the P20 terminal assembly (red monitor board) or red interface ribbon cable as specified in LA Specification No. 54-053-08.

Provide a P20 connector that mates with and is compatible with the red interface connector mounted on the front of the conflict monitor. Ensure that the P20 connector and the red interface connector on the conflict monitor are center polarized to ensure proper connection. Ensure that removal of the P20 connector will cause the conflict monitor to recognize a latching fault condition and place the cabinet into flashing operation.

Wire the P20 connector to the output file and auxiliary output file using 22 AWG stranded wires. Ensure the length of these wires is a minimum of 42 inches in length. Provide a durable braided sleeve around the wires to organize and protect the wires.

Wire the P20 connector to the traffic signal red displays to provide inputs to the conflict monitor as shown below. Ensure the pedestrian Don't Walk circuits are wired to channels 13 through 16 of the P20 connector. When no auxiliary output file is installed in the cabinet, provide wires for channels 9 through 12 reds. Provide a wire for special function 1. Terminate the unused wires with ring type lugs, insulated, and bundled for optional use.

P20 Connector					
PIN	FUNCTION	CONN TO	PIN	FUNCTION	CONN TO
1	Channel 15 Red	119	2	Channel 16 Red	110
3	Channel 14 Red	104	4	Chassis GND	01-9
5	Channel 13 Red	113	6	N/C	
7	Channel 12 Red	AUX 101	8	Spec Function 1	
9	Channel 10 Red	AUX 124	10	Channel 11 Red	AUX 114
11	Channel 9 Red	AUX 121	12	Channel 8 Red	107
13	Channel 7 Red	122	14	Channel 6 Red	134
15	Channel 5 Red	131	16	Channel 4 Red	101
17	Channel 3 Red	116	18	Channel 2 Red	128
19	Channel 1 Red	125	20	Red Enable	01-14

Ensure the controller unit outputs to the auxiliary output file are pre-wired to the C5 connector. When no auxiliary output file is installed in the cabinet, connect the C5 connector to a storage socket located on the Input Panel or on the rear of the PDA.

Do not wire pin 12 of the load switch sockets.

In addition to the requirements of LA Specification No. 54-053-08, ensure relay K1 on the Power Distribution Assembly (PDA) is a four pole relay and K2 on the PDA is a two pole relay.

Provide a two pole, ganged circuit breaker for the flash bus circuit. Ensure the flash bus circuit breaker is an inverse time circuit breaker rated for 10 amps at 120 VAC with a minimum of 10,000 RMS symmetrical amperes short circuit current rating. Do not provide the auxiliary switch feature on the flash bus circuit breaker. Ensure the ganged flash bus circuit breaker is certified by the circuit breaker manufacturer to provide gang tripping operation.

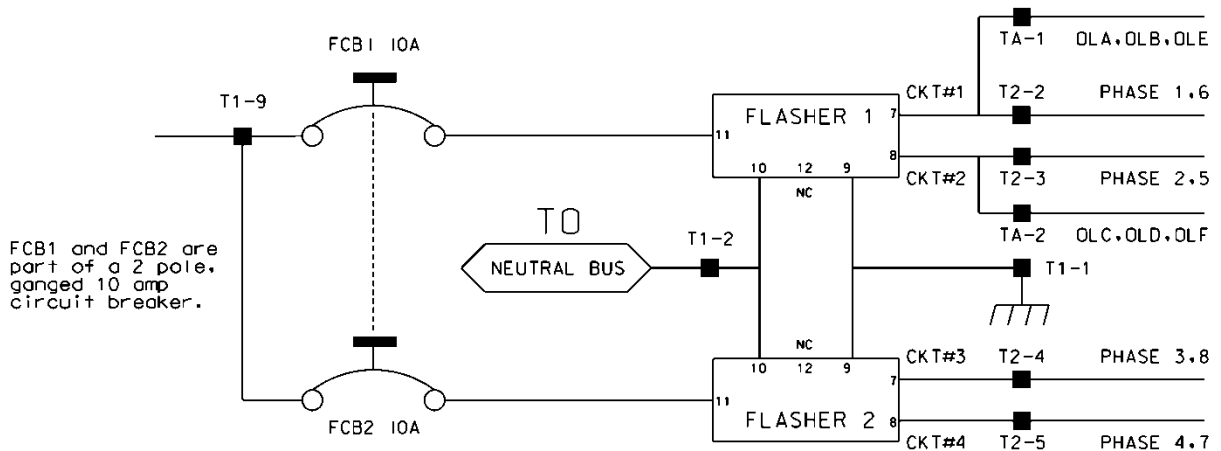

Ensure auxiliary output files are wired as follows:

<b>AUXILIARY OUTPUT FILE</b>	
<b>TERMINAL BLOCK TA ASSIGNMENTS</b>	
<b>POSITION</b>	<b>FUNCTION</b>
1	Flasher Unit #1, Circuit 1/FTR1 (OLA, OLB)/FTR3 (OLE)
2	Flasher Unit #1, Circuit 2/FTR2 (OLC, OLD)/FTR3 (OLF)
3	Flash Transfer Relay Coils
4	AC -
5	Power Circuit 5
6	Power Circuit 5
7	Equipment Ground Bus
8	NC

Provide four spare load resistors mounted in each cabinet. Ensure each load resistor is rated as shown in the table below. Wire one side of each load resistor to AC-. Connect the other side of each resistor to a separate terminal on a four (4) position terminal block. Mount the load resistors and terminal block either inside the back of Output File No. 1 or on the upper area of the Service Panel.

ACCEPTABLE LOAD RESISTOR VALUES	
VALUE (ohms)	WATTAGE
1.5K – 1.9 K	25W (min)
2.0K – 3.0K	10W (min)

Provide Model 200 load switches, Model 204 flashers, Model 242 DC isolators, Model 252 AC isolators, and Model 206L power supply units that conform to CALTRANS' *Transportation Electrical Equipment Specifications* dated March 12, 2009 with Erratum 1.

### C. Type 170 E Cabinet Physical Requirements:

Do not mold, cast, or scribe the name "City of Los Angeles" on the outside of the cabinet door as specified in LA Specification No. 54-053-08. Do not provide a Communications Terminal Panel as specified in LA Specification No. 54-053-08. Do not provide terminal block TBB on the Service Panel. Do not provide Cabinet Verification Test Program software or associated test jigs as specified in LA Specification No. 54-053-08.

Furnish unpainted, natural, aluminum cabinet shells. Ensure that all non-aluminum hardware on the cabinet is stainless steel or a Department approved non-corrosive alternate.

Ensure the lifting eyes, gasket channels, police panel, and all supports welded to the enclosure and doors are fabricated from 0.125 inch minimum thickness aluminum sheet and meet the same standards as the cabinet and doors.

Provide front and rear doors with latching handles that allow padlocking in the closed position. Furnish 0.75 inch minimum diameter stainless steel handles with a minimum 0.5 inch shank. Place the padlocking attachment at 4.0 inches from the handle shank center to clear the lock and key. Provide an additional 4.0 inches minimum gripping length.

Provide Corbin #2 locks on the front and rear doors. Provide one (1) Corbin #2 and one (1) police master key with each cabinet. Ensure main door locks allow removal of keys in the locked position only.

Provide a surge protection panel with 16 loop surge protection devices and designed to allow sufficient free space for wire connection/disconnection and surge protection device replacement. For model 332 cabinets, provide an additional 20 loop surge protection devices. Provide an additional two AC+ interconnect surge devices to protect one slot and eight DC surge protection devices to protect four slots. Provide no protection devices on slot I14.

For base mounted cabinets, mount surge protection panels on the left side of the cabinet as viewed from the rear. Attach each panel to the cabinet rack assembly using bolts and make it easily removable. Mount the surge protection devices in vertical rows on each panel and connect the devices to one side of 12 position, double row terminal blocks with #8 screws. For each surge

protection panel, terminate all grounds from the surge protection devices on a copper equipment ground bus attached to the surge protection panel. Wire the terminals to the rear of a standard input file using spade lugs for input file protection.

Provide permanent labels that indicate the slot and the pins connected to each terminal that may be viewed from the rear cabinet door. Label and orient terminals so that each pair of inputs is next to each other. Indicate on the labeling the input file (I or J), the slot number (1-14) and the terminal pins of the input slots (either D & E for upper or J & K for lower).

Provide a minimum 14 x 16 inch pull out, hinged top shelf located immediately below controller mounting section of the cabinet. Ensure the shelf is designed to fully expose the table surface outside the controller at a height approximately even with the bottom of the controller. Ensure the shelf has a storage bin interior which is a minimum of 1 inch deep and approximately the same dimensions as the shelf. Provide an access to the storage area by lifting the hinged top of the shelf. Fabricate the shelf and slide from aluminum or stainless steel and ensure the assembly can support the 2070L controller plus 15 pounds of additional weight. Ensure shelf has a locking mechanism to secure it in the fully extended position and does not inhibit the removal of the 2070L controller or removal of cards inside the controller when fully extended. Provide a locking mechanism that is easily released when the shelf is to be returned to its non-use position directly under the controller.

#### **D. Model 2018 Enhanced Conflict Monitor:**

Furnish Model 2018 Enhanced Conflict Monitors that provide monitoring of 18 channels. Ensure each channel consists of a green, yellow, and red field signal input. Ensure that the conflict monitor meets or exceeds CALTRANS' Transportation Electrical Equipment Specifications dated March 12, 2009, with Erratum 1 (hereafter referred to as CALTRANS' 2009 TEES) for a model 210 monitor unit and other requirements stated in this specification.

Ensure the conflict monitor is provided with an 18 channel conflict programming card. Pin EE and Pin T of the conflict programming card shall be connected together. Pin 16 of the conflict programming card shall be floating. Ensure that the absence of the conflict programming card will cause the conflict monitor to trigger (enter into fault mode), and remain in the triggered state until the programming card is properly inserted and the conflict monitor is reset.

Provide a conflict monitor that incorporates LED indicators into the front panel to dynamically display the status of the monitor under normal conditions and to provide a comprehensive review of field inputs with monitor status under fault conditions. Ensure that the monitor indicates the channels that were active during a conflict condition and the channels that experienced a failure for all other per channel fault conditions detected. Ensure that these indications and the status of each channel are retained until the Conflict Monitor is reset. Furnish LED indicators for the following:

- AC Power (Green LED indicator)
- VDC Failed (Red LED indicator)
- WDT Error (Red LED indicator)
- Conflict (Red LED indicator)
- Red Fail (Red LED indicator)
- Dual Indication (Red LED indicator)
- Yellow/Clearance Failure (Red LED indicator)
- PCA/PC Ajar (Red LED indicator)

- Monitor Fail/Diagnostic Failure (Red LED indicator)
- 54 Channel Status Indicators (1 Red, 1 Yellow, and 1 Green LED indicator for each of the 18 channels)

Provide a switch to set the Red Fail fault timing. Ensure that when the switch is in the ON position the Red Fail fault timing value is set to 1350 +/- 150 ms (2018 mode). Ensure that when the switch is in the OFF position the Red Fail fault timing value is set to 850 +/- 150 ms (210 mode).

Provide a switch to set the Watchdog fault timing. Ensure that when the switch is in the ON position the Watchdog fault timing value is set to 1.0 +/- 0.1 s (2018 mode). Ensure that when the switch is in the OFF position the Watchdog fault timing value is set to 1.5 +/- 0.1 s (210 mode).

Provide a jumper or switch to set the AC line brown-out levels. Ensure that when the jumper is present or the switch is in the ON position the AC line dropout voltage threshold is 98 +/- 2 Vrms, the AC line restore voltage threshold is 103 +/- 2 Vrms, and the AC line brown-out timing value is set to 400 +/- 50ms (2018 mode). Ensure that when the jumper is not present or the switch is in the OFF position the AC line dropout voltage threshold is 92 +/- 2 Vrms, the AC line restore voltage threshold is 98 +/- 2 Vrms, and the AC line brown-out timing value is set to 80 +/- 17 ms (210 mode).

Provide a jumper or switch that will enable and disable the Watchdog Latch function. Ensure that when the jumper is not present or the switch is in the OFF position the Watchdog Latch function is disabled. In this mode of operation, a Watchdog fault will be reset following a power loss, brownout, or power interruption. Ensure that when the jumper is present or the switch is in the ON position the Watchdog Latch function is enabled. In this mode of operation, a Watchdog fault will be retained until a Reset command is issued.

Provide a jumper that will reverse the active polarity for pin #EE (output relay common). Ensure that when the jumper is not present pin #EE (output relay common) will be considered 'Active' at a voltage greater than 70 Vrms and 'Not Active' at a voltage less than 50 Vrms (Caltrans mode). Ensure that when the jumper is present pin #EE (output relay common) will be considered 'Active' at a voltage less than 50 Vrms and 'Not Active' at a voltage greater than 70 Vrms (Failsafe mode).

In addition to the connectors required by CALTRANS' 2009 TEES, provide the conflict monitor with a red interface connector mounted on the front of the monitor. Ensure the connector is a 20 pin, right angle, center polarized, male connector with latching clip locks and polarizing keys. Ensure the right angle solder tails are designed for a 0.062" thick printed circuit board. Keying of the connector shall be between pins 3 and 5, and between 17 and 19. Ensure the connector has two rows of pins with the odd numbered pins on one row and the even pins on the other row. Ensure the connector pin row spacing is 0.10" and pitch is 0.10". Ensure the mating length of the connector pins is 0.24". Ensure the pins are finished with gold plating 30μ" thick.

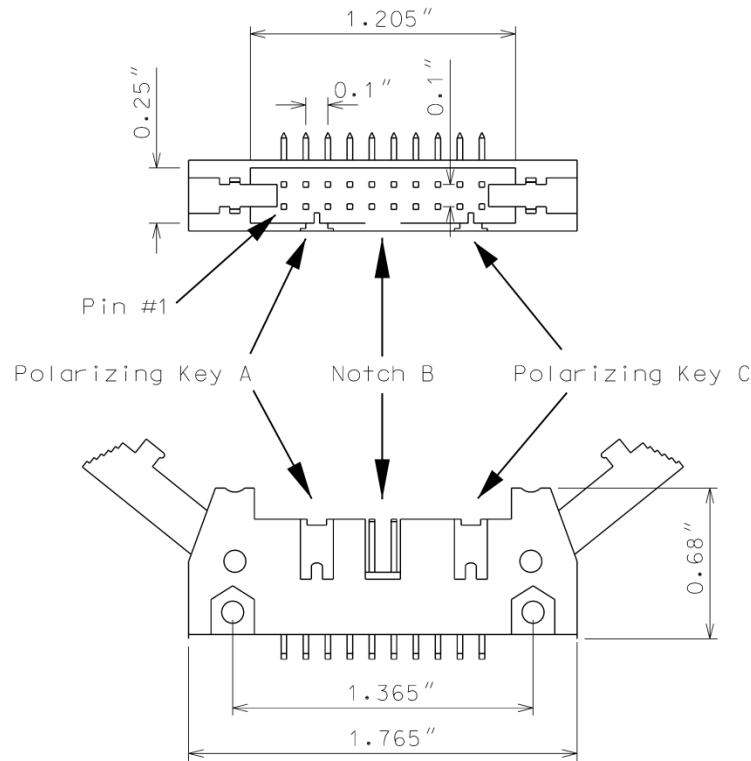

Ensure the red interface connector pins on the monitor have the following functions:

Pin #	Function	Pin #	Function
1	Channel 15 Red	2	Channel 16 Red
3	Channel 14 Red	4	Chassis Ground
5	Channel 13 Red	6	Special Function 2
7	Channel 12 Red	8	Special Function 1
9	Channel 10 Red	10	Channel 11 Red
11	Channel 9 Red	12	Channel 8 Red
13	Channel 7 Red	14	Channel 6 Red
15	Channel 5 Red	16	Channel 4 Red
17	Channel 3 Red	18	Channel 2 Red
19	Channel 1 Red	20	Red Enable

Ensure that removal of the P20 cable connector will cause the conflict monitor to recognize a latching fault condition and place the cabinet into flashing operation.

Provide Special Function 1 and Special Function 2 inputs to the unit which shall disable only Red Fail Monitoring when either input is sensed active. A Special Function input shall be sensed active when the input voltage exceeds 70 Vrms with a minimum duration of 550 ms. A Special Function

input shall be sensed not active when the input voltage is less than 50 Vrms or the duration is less than 250 ms. A Special Function input is undefined by these specifications and may or may not be sensed active when the input voltage is between 50 Vrms and 70 Vrms or the duration is between 250 ms and 550 ms.

Ensure the conflict monitor recognizes field signal inputs for each channel that meet the following requirements:

- consider a Red input greater than 70 Vrms and with a duration of at least 500 ms as an “on” condition;
- consider a Red input less than 50 Vrms or with a duration of less than 200 ms as an “off” condition (no valid signal);
- consider a Red input between 50 Vrms and 70 Vrms or with a duration between 200 ms and 500 ms to be undefined by these specifications;
- consider a Green or Yellow input greater than 25 Vrms and with a duration of at least 500 ms as an “on” condition;
- consider a Green or Yellow input less than 15 Vrms or with a duration of less than 200 ms as an “off” condition; and
- consider a Green or Yellow input between 15 Vrms and 25 Vrms or with a duration between 200 ms and 500 ms to be undefined by these specifications.

Provide a conflict monitor that recognizes the faults specified by CALTRANS’ 2009 TEES and the following additional faults. Ensure the conflict monitor will trigger upon detection of a fault and will remain in the triggered (in fault mode) state until the unit is reset at the front panel or through the external remote reset input for the following failures:

1. **Red Monitoring or Absence of Any Indication (Red Failure):** A condition in which no “on” voltage signal is detected on any of the green, yellow, or red inputs to a given monitor channel. If a signal is not detected on at least one input (R, Y, or G) of a conflict monitor channel for a period greater than 1000 ms when used with a 170 controller and 1500 ms when used with a 2070 controller, ensure monitor will trigger and put the intersection into flash. If the absence of any indication condition lasts less than 700 ms when used with a 170 controller and 1200 ms when used with a 2070 controller, ensure conflict monitor will not trigger. Red fail monitoring shall be enabled on a per channel basis by the use of switches located on the conflict monitor. Have red monitoring occur when all of the following input conditions are in effect:
  - a) Red Enable input to monitor is active (Red Enable voltages are “on” at greater than 70 Vrms, off at less than 50 Vrms, undefined between 50 and 70 Vrms), and
  - b) Neither Special Function 1 nor Special Function 2 inputs are active.
  - c) Pin #EE (output relay common) is not active
2. **Short/Missing Yellow Indication Fault (Clearance Error):** Yellow indication following a green is missing or shorter than 2.7 seconds (with  $\pm 0.1$ -second accuracy). If a channel fails to detect an “on” signal at the Yellow input for a minimum of 2.7 seconds ( $\pm 0.1$  second) following the detection of an “on” signal at a Green input for that channel, ensure that the monitor triggers and generates a clearance/short yellow error fault indication. Short/missing yellow (clearance) monitoring shall be enabled on a per channel basis by the use of switches



located on the conflict monitor. This fault shall not occur when the channel is programmed for Yellow Inhibit, when the Red Enable signal is inactive or pin #EE (output relay common) is active.

3. **Dual Indications on the Same Channel:** In this condition, more than one indication (R,Y,G) is detected as “on” at the same time on the same channel. If dual indications are detected for a period greater than 500 ms, ensure that the conflict monitor triggers and displays the proper failure indication (Dual Ind fault). If this condition is detected for less than 200 ms, ensure that the monitor does not trigger. G-Y-R dual indication monitoring shall be enabled on a per channel basis by the use of switches located on the conflict monitor. G-Y dual indication monitoring shall be enabled for all channels by use of a switch located on the conflict monitor. This fault shall not occur when the Red Enable signal is inactive or pin #EE (output relay common) is active.
4. **Configuration Settings Change:** The configuration settings are comprised of (as a minimum) the permissive diode matrix, dual indication switches, yellow disable jumpers, any option switches, any option jumpers, and the Watchdog Enable switch. Ensure the conflict monitor compares the current configuration settings with the previous stored configuration settings on power-up, on reset, and periodically during operation. If any of the configuration settings are changed, ensure that the conflict monitor triggers and causes the program card indicator to flash. Ensure that configuration change faults are only reset by depressing and holding the front panel reset button for a minimum of three seconds. Ensure the external remote reset input does not reset configuration change faults.

Ensure the conflict monitor will trigger and the AC Power indicator will flash at a rate of  $2 \text{ Hz} \pm 20\%$  with a 50% duty cycle when the AC Line voltage falls below the “drop-out” level. Ensure the conflict monitor will resume normal operation when the AC Line voltage returns above the “restore” level. Ensure the AC Power indicator will remain illuminated when the AC voltage returns above the “restore” level. Should an AC Line power interruption occur while the monitor is in the fault mode, then upon restoration of AC Line power, the monitor will remain in the fault mode and the correct fault and channel indicators will be displayed.

Provide a flash interval of at least 6 seconds and at most 10 seconds in duration following a power-up, an AC Line interruption, or a brownout restore. Ensure the conflict monitor will suspend all fault monitoring functions, close the Output relay contacts, and flash the AC indicator at a rate of  $4 \text{ Hz} \pm 20\%$  with a 50% duty cycle during this interval. Ensure the termination of the flash interval after at least 6 seconds if the Watchdog input has made 5 transitions between the True and False state and the AC Line voltage is greater than the “restore” level. If the watchdog input has not made 5 transitions between the True and False state within  $10 \pm 0.5$  seconds, the monitor shall enter a WDT error fault condition.

Ensure the conflict monitor will monitor an intersection with a minimum of four approaches using the four-section Flashing Yellow Arrow (FYA) vehicle traffic signal as outlined by the NCHRP 3-54 research project for protected-permissive left turn signal displays. Ensure the conflict monitor will operate in the FYA mode and FYAc (Compact) mode as specified below to monitor each channel pair for the following fault conditions: Conflict, Flash Rate Detection, Red Fail, Dual Indication, and Clearance. Provide a switch to select between the FYA mode and FYAc mode. Provide a switch to select each FYA phase movement for monitoring.

**FYA mode**

FYA Signal Head	Phase 1	Phase 3	Phase 5	Phase 7
Red Arrow	Channel 9 Red	Channel 10 Red	Channel 11 Red	Channel 12 Red
Yellow Arrow	Channel 9 Yellow	Channel 10 Yellow	Channel 11 Yellow	Channel 12 Yellow
Flashing Yellow Arrow	Channel 9 Green	Channel 10 Green	Channel 11 Green	Channel 12 Green
Green Arrow	Channel 1 Green	Channel 3 Green	Channel 5 Green	Channel 7 Green

**FYAc mode**

FYA Signal Head	Phase 1	Phase 3	Phase 5	Phase 7
Red Arrow	Channel 1 Red	Channel 3 Red	Channel 5 Red	Channel 7 Red
Yellow Arrow	Channel 1 Yellow	Channel 3 Yellow	Channel 5 Yellow	Channel 7 Yellow
Flashing Yellow Arrow	Channel 1 Green	Channel 3 Green	Channel 5 Green	Channel 7 Green
Green Arrow	Channel 9 Green	Channel 9 Yellow	Channel 10 Green	Channel 10 Yellow

If a FYA channel pair is enabled for FYA operation, the conflict monitor will monitor the FYA logical channel pair for the additional following conditions:

1. **Conflict:** Channel conflicts are detected based on the permissive programming jumpers on the program card. This operation remains unchanged from normal operation except for the solid Yellow arrow (FYA clearance) signal.
2. **Yellow Change Interval Conflict:** During the Yellow change interval of the Permissive Turn channel (flashing Yellow arrow) the conflict monitor shall verify that no conflicting channels to the solid Yellow arrow channel (clearance) are active. These conflicting channels shall be determined by the program card compatibility programming of the Permissive Turn channel (flashing Yellow arrow). During the Yellow change interval of the Protected Turn channel (solid Green arrow) the conflict monitor shall verify that no conflicting channels to the solid Yellow arrow channel (clearance) are active as determined by the program card compatibility programming of the Protected Turn channel (solid Green arrow).

3. **Flash Rate Detection:** The conflict monitor unit shall monitor for the absence of a valid flash rate for the Permissive turn channel (flashing Yellow arrow). If the Permissive turn channel (flashing Yellow arrow) is active for a period greater than 1600 milliseconds, ensure the conflict monitor triggers and puts the intersection into flash. If the Permissive turn channel (flashing Yellow arrow) is active for a period less than 1400 milliseconds, ensure the conflict monitor does not trigger. Ensure the conflict monitor will remain in the triggered (in fault mode) state until the unit is reset at the front panel or through the external remote reset input. Provide a jumper or switch that will enable and disable the Flash Rate Detection function. Ensure that when the jumper is not present or the switch is in the OFF position the Flash Rate Detection function is enabled. Ensure that when the jumper is present or the switch is in the ON position the Flash Rate Detection function is disabled.
4. **Red Monitoring or Absence of Any Indication (Red Failure):** The conflict monitor unit shall detect a red failure if there is an absence of voltage on all four of the inputs of a FYA channel pair (RA, YA, FYA, GA).
5. **Dual Indications on the Same Channel:** The conflict monitor unit shall detect a dual indication if two or more inputs of a FYA channel pair (RA, YA, FYA, GA) are “on” at the same time.
6. **Short/Missing Yellow Indication Fault (Clearance Error):** The conflict monitor unit shall monitor the solid Yellow arrow for a clearance fault when terminating both the Protected Turn channel (solid Green arrow) interval and the Permissive Turn channel (flashing Yellow arrow) interval.

Ensure that the conflict monitor will log at least nine of the most recent events detected by the monitor in non-volatile EEPROM memory (or equivalent). For each event, record at a minimum the time, date, type of event, status of each field signal indication with RMS voltage, and specific channels involved with the event. Ensure the conflict monitor will log the following events: monitor reset, configuration, previous fault, and AC line. Furnish the signal sequence log that shows all channel states (Greens, Yellows, and Reds) and the Red Enable State for a minimum of 2 seconds prior to the current fault trigger point. Ensure the display resolution of the inputs for the signal sequence log is not greater than 50 ms.

For conflict monitors used within an Ethernet communications system, provide a conflict monitor with an Ethernet 10/100 Mbps, RJ-45 port for data communication access to the monitor by a local notebook computer and remotely via a workstation or notebook computer device connected to the signal system local area network. The Ethernet port shall be electrically isolated from the conflict monitor’s electronics and shall provide a minimum of 1500 Vrms isolation. Integrate monitor with Ethernet network in cabinet. Provide software to retrieve the time and date from a network server in order to synchronize the on-board times between the conflict monitor and the controller. Furnish and install the following Windows based, graphic user interface software on workstations and notebook computers where the signal system client software is installed: 1) software to view and retrieve all event log information, 2) software that will search and display a list of conflict monitor IP addresses and IDs on the network, and 3) software to change the conflict monitor’s network parameters such as IP address and subnet mask.

For non-Ethernet connected monitors, provide a RS-232C/D compliant port (DB-9 female connector) on the front panel of the conflict monitor in order to provide communications from the conflict monitor to the 170/2070 controller or to a Department-furnished laptop computer.

Electrically isolate the port interface electronics from all monitor electronics, excluding Chassis Ground. Ensure that the controller can receive all event log information through a controller Asynchronous Communications Interface Adapter (Type 170E) or Async Serial Comm Module (2070). Furnish and connect a serial cable from the conflict monitor's DB-9 connector to Comm Port 1 of the 2070 controller. Ensure conflict monitor communicates with the controller. Provide a Windows based graphic user interface software to communicate directly through the same monitor RS-232C/D compliant port to retrieve and view all event log information to a Department-furnished laptop computer. The RS-232C/D compliant port on the monitor shall allow the monitor to function as a DCE device with pin connections as follows:

<b>Conflict Monitor RS-232C/D (DB-9 Female) Pinout</b>		
<b>Pin Number</b>	<b>Function</b>	<b>I/O</b>
1	DCD	O
2	TX Data	O
3	RX Data	I
4	DTR	I
5	Ground	-
6	DSR	O
7	CTS	I
8	RTS	O
9	NC	-

---

**MONITOR BOARD EDGE CONNECTOR**

---

<b>Pin #</b>	<b>Function (Back Side)</b>	<b>Pin #</b>	<b>Function (Component Side)</b>
1	Channel 2 Green	A	Channel 2 Yellow
2	Channel 13 Green	B	Channel 6 Green
3	Channel 6 Yellow	C	Channel 15 Green
4	Channel 4 Green	D	Channel 4 Yellow
5	Channel 14 Green	E	Channel 8 Green
6	Channel 8 Yellow	F	Channel 16 Green
7	Channel 5 Green	H	Channel 5 Yellow
8	Channel 13 Yellow	J	Channel 1 Green
9	Channel 1 Yellow	K	Channel 15 Yellow
10	Channel 7 Green	L	Channel 7 Yellow
11	Channel 14 Yellow	M	Channel 3 Green
12	Channel 3 Yellow	N	Channel 16 Yellow
13	Channel 9 Green	P	Channel 17 Yellow
14	Channel 17 Green	R	Channel 10 Green
15	Channel 11 Yellow	S	Channel 11 Green
16	Channel 9 Yellow	T	Channel 18 Yellow
17	Channel 18 Green	U	Channel 10 Yellow
--		--	
18	Channel 12 Yellow	V	Channel 12 Green
19	Channel 17 Red	W	Channel 18 Red
20	Chassis Ground	X	Not Assigned
21	AC-	Y	DC Common
22	Watchdog Timer	Z	External Test Reset
23	+24VDC	AA	+24VDC
24	Tied to Pin 25	BB	Stop Time (Output)
25	Tied to Pin 24	CC	Not Assigned
26	Not Assigned	DD	Not Assigned
27	Relay Output, Side #3, N.O.	EE	Relay Output, Side #2, Common
28	Relay Output, Side #1, N.C.	FF	AC+

-- Slotted for keying between Pins 17/U and 18/V

---

**CONFLICT PROGRAM CARD PIN ASSIGNMENTS**

---

<b>Pin #</b>	<b>Function (Back Side)</b>	<b>Pin #</b>	<b>Function (Component Side)</b>
1	Channel 2 Green	A	Channel 1 Green
2	Channel 3 Green	B	Channel 2 Green
3	Channel 4 Green	C	Channel 3 Green
4	Channel 5 Green	D	Channel 4 Green
5	Channel 6 Green	E	Channel 5 Green
6	Channel 7 Green	F	Channel 6 Green
7	Channel 8 Green	H	Channel 7 Green
8	Channel 9 Green	J	Channel 8 Green
9	Channel 10 Green	K	Channel 9 Green
10	Channel 11 Green	L	Channel 10 Green
11	Channel 12 Green	M	Channel 11 Green
12	Channel 13 Green	N	Channel 12 Green
13	Channel 14 Green	P	Channel 13 Green
14	Channel 15 Green	R	Channel 14 Green
15	Channel 16 Green	S	Channel 15 Green
16	N/C	T	PC AJAR
17	Channel 1 Yellow	U	Channel 9 Yellow
18	Channel 2 Yellow	V	Channel 10 Yellow
19	Channel 3 Yellow	W	Channel 11 Yellow
20	Channel 4 Yellow	X	Channel 12 Yellow
21	Channel 5 Yellow	Y	Channel 13 Yellow
22	Channel 6 Yellow	Z	Channel 14 Yellow
23	Channel 7 Yellow	AA	Channel 15 Yellow
24	Channel 8 Yellow	BB	Channel 16 Yellow
--		--	
25	Channel 17 Green	CC	Channel 17 Yellow
26	Channel 18 Green	DD	Channel 18 Yellow
27	Channel 16 Green	EE	PC AJAR (Program Card)
28	Yellow Inhibit Common	FF	Channel 17 Green

-- Slotted for keying between Pins 24/BB and 25/CC

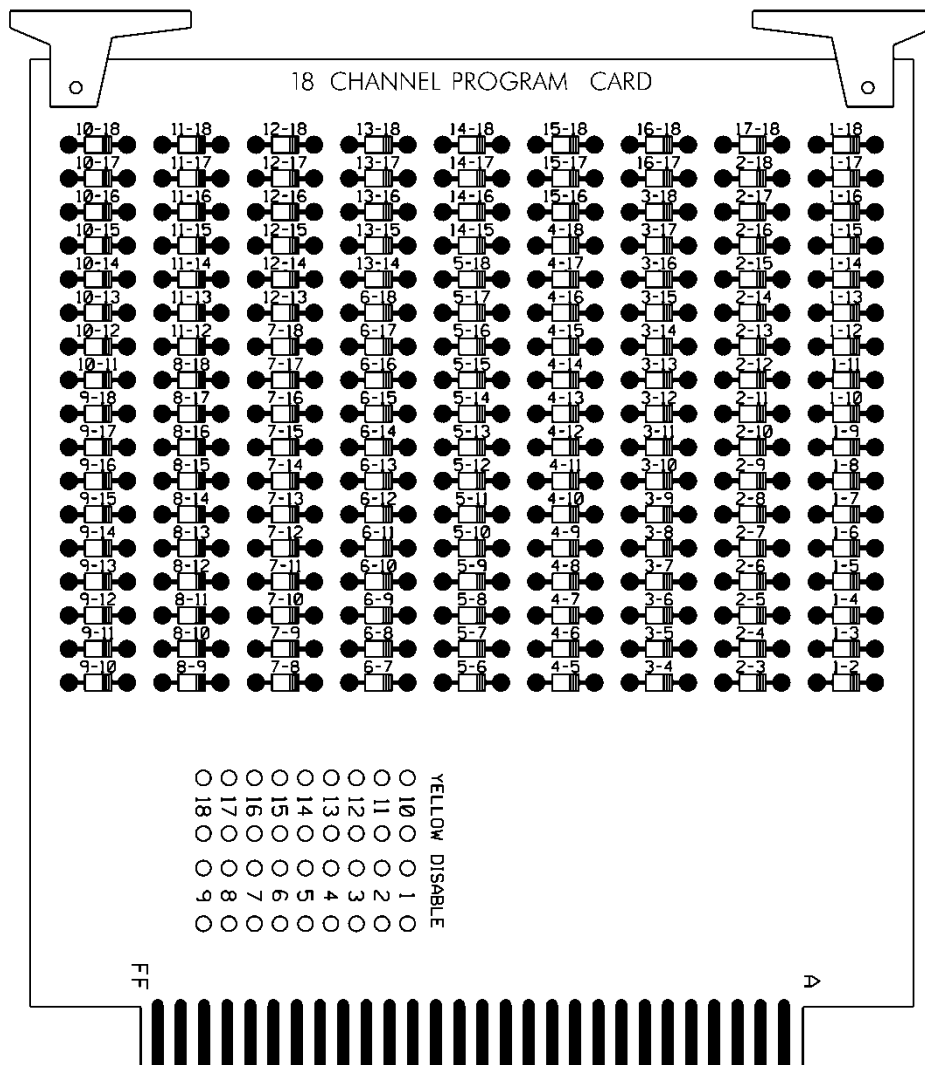

**5.4. MATERIALS – TYPE 170 DETECTOR SENSOR UNITS**

Furnish detector sensor units that comply with Chapter 5 Section 1, “General Requirements,” and Chapter 5 Section 2, “Model 222 & 224 Loop Detector Sensor Unit Requirements,” of the CALTRANS “Transportation Electrical Equipment Specifications” dated March 12, 2009 with Erratum 1.

**5.5. MATERIALS – TYPE 2070E CONTROLLERS**

Conform to CALTRANS *Transportation Electrical Equipment Specifications* (TEES) (dated March 12, 2009, plus Errata 1 dated January 21, 2010) except as required herein.

Furnish Model 2070E controllers. Ensure that removal of the CPU module from the controller will place the intersection into flash.

The Department will provide software at the beginning of the burning-in period. Contractor shall give 5 working days notice before needing software. Program software provided by the Department.

Provide Model 2070E controllers with the latest version of OS9 operating software and device drivers, composed of the unit chassis and at a minimum the following modules and assemblies:

- MODEL 2070-1E, CPU Module, Single Board, with 8Mb Datakey (blue in color)
- MODEL 2070-2A or approved MODEL 2070-2E, Field I/O Module (FI/O)
  - Note: Configure the Field I/O Module to disable both the External WDT Shunt/Toggle Switch and SP3 (SP3 active indicator is “off”)
- MODEL 2070-3B, Front Panel Module (FP), Display B (8x40)
- MODEL 2070-4, Power Supply Module, 10 AMP
- MODEL 2070-7A, Async Serial Com Module (9-pin RS-232)

Furnish one additional MODEL 2070-7A, Async Serial Com Module (9-pin RS-232) for all master controller locations.

For each master location and central control center, furnish a U.S. Robotics V.92 or approved equivalent auto-dial/auto-answer external modem to accomplish the interface to the Department-furnished microcomputers. Include all necessary hardware to ensure telecommunications.



**U-2579C**  
**INTELLIGENT TRANSPORTATION SYSTEMS**  
**CCTV AND DMS INSTALLATIONS**

**PROJECT SPECIAL PROVISIONS**

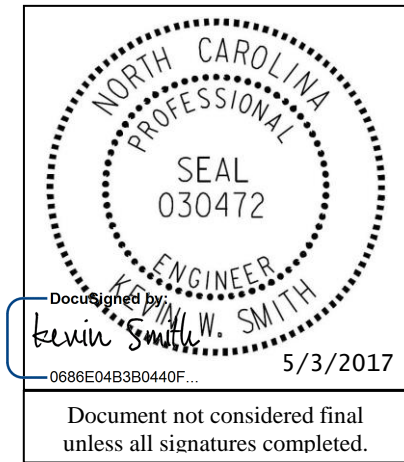

**Contents**

**1. GENERAL REQUIREMENTS..... 7**

1.1. DESCRIPTION ..... 7

    A. *General*..... 7

    B. *Scope* ..... 7

    C. *2012 Standard Specifications for Roads and Structures*..... 7

1.2. MATERIAL ..... 8

    A. *Qualified Products* ..... 8

    B. *Plan of Record Documentation* ..... 8

**2. UNDERGROUND CONDUIT..... 9**

2.1. DESCRIPTION ..... 9

2.2. MATERIAL ..... 9

2.3. CONSTRUCTION METHODS ..... 9

2.4. MEASUREMENT AND PAYMENT ..... 9

**3. JUNCTION BOXES..... 11**

3.1. DESCRIPTION ..... 11

3.2. MATERIAL ..... 11

3.3. CONSTRUCTION METHODS ..... 11

3.4. MEASUREMENT AND PAYMENT ..... 11

**4. WOOD POLES ..... 12**

4.1. DESCRIPTION ..... 12

4.2. MATERIAL ..... 12

    A. *General*..... 12

    B. *Wood Pedestal*..... 12

    C. *Wood Pole* ..... 12

4.3. CONSTRUCTION METHOD ..... 12

4.4. MEASUREMENT AND PAYMENT ..... 12

**5. RISER ASSEMBLIES..... 13**

5.1. DESCRIPTION ..... 13

5.2. MATERIAL ..... 13

5.3. CONSTRUCTION METHOD ..... 13

5.4. MEASUREMENT AND PAYMENT ..... 13

**6. GUY ASSEMBLIES ..... 14**

6.1. DESCRIPTION ..... 14

6.2. MATERIAL ..... 14

6.3. CONSTRUCTION METHOD ..... 14

6.4. MEASUREMENT AND PAYMENT ..... 14

**7. MESSENGER CABLE..... 15**

7.1. DESCRIPTION ..... 15

7.2. MATERIAL ..... 15

7.3. CONSTRUCTION METHOD ..... 15

7.4. MEASUREMENT AND PAYMENT ..... 15

**8. FIBER-OPTIC CABLE ..... 16**

8.1. DESCRIPTION ..... 16

8.2. MATERIAL ..... 16

8.3. CONSTRUCTION METHODS ..... 16

8.4. MEASUREMENT AND PAYMENT ..... 16

**9. DELINEATOR MARKERS ..... 17**

9.1. DESCRIPTION ..... 17

9.2. MATERIALS ..... 17

9.3. CONSTRUCTION METHODS ..... 17

9.4. MEASUREMENT AND PAYMENT ..... 17

**10. FIBER-OPTIC SPLICE CENTERS ..... 18**

10.1. DESCRIPTION ..... 18

10.2. MATERIALS ..... 18

10.3. CONSTRUCTION METHODS ..... 18

10.4. MEASUREMENT AND PAYMENT ..... 18

**11. SPLICE CABINET (FIBER OPTICS) ..... 19**

11.1. DESCRIPTION ..... 19

11.2. MATERIALS ..... 19

11.3. CONSTRUCTION METHODS ..... 19

11.4. MEASUREMENT AND PAYMENT ..... 19

**12. EQUIPMENT CABINET FOUNDATIONS ..... 20**

12.1. DESCRIPTION ..... 20

12.2. MATERIAL ..... 20

12.3. CONSTRUCTION METHODS ..... 20

12.4. MEASUREMENT AND PAYMENT ..... 20

**13. ELECTRICAL SERVICE ..... 21**

13.1. DESCRIPTION ..... 21

13.2. MATERIAL ..... 21

    A. *Meter Base/Disconnect Combination Panel* ..... 21

    B. *Equipment Cabinet Disconnect* ..... 22

C.	4-Wire Copper Feeder Conductors.....	22
D.	3-Wire Copper Feeder Conductors.....	22
E.	Grounding System .....	23
13.3.	CONSTRUCTION METHODS .....	23
A.	General.....	23
B.	Meter Base/Disconnect Combination Panel .....	23
C.	Electrical Service Disconnect .....	23
D.	4-Wire Copper Feeder Conductors.....	23
E.	3-Wire Copper Feeder Conductors.....	23
F.	Grounding System .....	23
13.4.	MEASUREMENT AND PAYMENT .....	23
<b>14.</b>	<b>CCTV CAMERA EQUIPMENT.....</b>	<b>25</b>
14.1.	DESCRIPTION .....	25
14.2.	MATERIAL .....	25
A.	General.....	25
B.	Camera and Lens.....	25
C.	Camera Housing.....	26
D.	Pan and Tilt Unit.....	26
E.	Video Ethernet Encoder .....	27
F.	Control Receiver/Driver.....	27
G.	Ethernet Cable.....	28
H.	CCTV Camera Attachment to Pole .....	28
I.	Surge Suppression .....	28
14.3.	CONSTRUCTION METHODS .....	28
A.	General.....	28
B.	Electrical and Mechanical Requirements .....	28
14.4.	MEASUREMENT AND PAYMENT .....	29
<b>15.</b>	<b>FIELD EQUIPMENT CABINET .....</b>	<b>30</b>
15.1.	DESCRIPTION .....	30
15.2.	MATERIAL .....	30
A.	Shelf Drawer.....	30
B.	Cabinet Light.....	30
C.	Surge Protection for System Equipment.....	30
15.3.	CONSTRUCTION METHODS.....	33
15.4.	MEASUREMENT AND PAYMENT .....	33
<b>16.</b>	<b>CCTV METAL POLES .....</b>	<b>34</b>
16.1.	DESCRIPTION .....	34
A.	CCTV Metal Poles.....	34
B.	Drilled Pier Foundations .....	34
C.	Soil Test.....	34
16.2.	MATERIALS .....	36
A.	CCTV Metal Poles.....	36
16.3.	CONSTRUCTION METHODS.....	39
A.	CCTV Metal Poles.....	39
B.	Drilled Pier Foundations .....	40

16.4. MEASUREMENT AND PAYMENT ..... 40

**17. DYNAMIC MESSAGE SIGN (DMS)..... 41**

17.1. DESCRIPTION ..... 41

    A. *General Requirements* ..... 41

    B. *DMS Requirements* ..... 41

17.2. MATERIALS ..... 41

    A. *Environmental Requirements* ..... 41

    B. *Full Matrix LED Dynamic Message Sign (DMS)* ..... 41

    C. *DMS Enclosure Structure Mounting* ..... 47

    D. *DMS / DMS Controller Interconnect* ..... 48

    E. *DMS Controller and DMS Cabinet* ..... 48

    F. *Photo-Electric Sensors* ..... 55

    G. *Equipment List* ..... 55

    H. *Physical Description* ..... 55

    I. *Parts List* ..... 55

    J. *Character Set Submittal* ..... 55

    K. *Wiring Diagrams* ..... 55

    L. *Routine of Operation* ..... 56

    M. *Maintenance Procedures* ..... 56

    N. *Repair Procedures* ..... 56

    O. *Field Trial* ..... 56

17.3. CONSTRUCTION METHODS ..... 56

    A. *Description* ..... 56

    B. *Layout* ..... 57

    C. *Construction Submittal* ..... 57

    D. *Conduit* ..... 57

    E. *Wiring Methods* ..... 58

    F. *Equipment and Cabinet Mounting* ..... 58

    G. *Work Site Clean-Up* ..... 58

17.4. MEASUREMENT AND PAYMENT ..... 58

**18. NTCIP REQUIREMENTS ..... 60**

18.1. REFERENCES ..... 60

    A. *General Requirements* ..... 61

    B. *NTCIP Acceptance Testing* ..... 68

18.2. MEASUREMENT AND PAYMENT ..... 69

**19. DMS ASSEMBLIES ..... 70**

19.1. DESCRIPTION ..... 70

19.2. MATERIAL ..... 70

19.3. CONSTRUCTION METHODS ..... 70

    A. *General* ..... 70

    B. *Shop Drawing* ..... 71

    C. *Design and Fabrication* ..... 71

19.4. MEASUREMENT AND PAYMENT ..... 73

**20. FOUNDATIONS AND ANCHOR ROD ASSEMBLIES FOR METAL POLES ..... 74**

20.1. DESCRIPTION .....	74
20.2. MATERIAL .....	74
20.3. CONSTRUCTION METHODS .....	75
A. <i>Drilled Piers</i> .....	75
B. <i>Footings, Pedestals, Grade Beams and Wings</i> .....	77
C. <i>Anchor Rod Assemblies</i> .....	77
20.4. MEASUREMENT AND PAYMENT .....	79
<b>21. DYNAMIC MESSAGE SIGN STRUCTURE FOUNDATIONS .....</b>	<b>80</b>
21.1. DESCRIPTION .....	80
21.2. MATERIAL .....	80
A. <i>Assumed Subsurface Conditions</i> .....	80
B. <i>Subsurface Investigations</i> .....	80
C. <i>Sign Foundation Designs</i> .....	80
21.3. CONSTRUCTION METHODS .....	81
21.4. MEASUREMENT AND PAYMENT .....	81
<b>22. LOCAL AREA NETWORK HARDWARE .....</b>	<b>82</b>
22.1. DESCRIPTION .....	82
22.2. MATERIAL .....	82
A. <i>General</i> .....	82
B. <i>Ethernet Edge Switch</i> .....	84
C. <i>Central Digital Hardware Video Decoders</i> .....	86
D. <i>Central Media Converter</i> .....	87
E. <i>Ethernet Cable</i> .....	87
22.3. CONSTRUCTION METHODS .....	89
A. <i>General</i> .....	89
B. <i>Requirements Definition Document</i> .....	89
C. <i>Ethernet Edge Switch</i> .....	90
D. <i>Central Digital Hardware Video Decoder</i> .....	90
E. <i>Central Media Converter</i> .....	90
F. <i>Cellular Modem and Antenna</i> .....	90
G. <i>Ethernet Cable</i> .....	91
22.4. MEASUREMENT AND PAYMENT .....	91
<b>23. INTEGRATION AND CONFIGURATION .....</b>	<b>93</b>
23.1. DESCRIPTION .....	93
23.2. CENTRAL INTEGRATION .....	93
23.3. CENTRAL CONFIGURATION .....	93
23.4. MEASUREMENT AND PAYMENT .....	94
<b>24. TESTING &amp; ACCEPTANCE .....</b>	<b>95</b>
24.1. GENERAL TEST PROCEDURE .....	95
24.2. DESIGN APPROVAL TESTS .....	95
A. <i>DMS System</i> .....	95
B. <i>CCTV System</i> .....	96
C. <i>Fiber Optic Communications</i> .....	96
D. <i>Central Hardware</i> .....	96

24.3. COMPATIBILITY TESTS ..... 96

- A. *DMS System*..... 96
- B. *CCTV System*..... 96
- C. *Fiber Optic Communications* ..... 96
- D. *Central Hardware* ..... 96

24.4. OPERATIONAL FIELD TEST (ON-SITE COMMISSIONING)..... 97

- A. *DMS System*..... 97
- B. *CCTV System*..... 98
- C. *Fiber Optic Communications* ..... 99
- D. *Central Hardware* ..... 100

24.5. SYSTEM OPERATIONAL TEST..... 100

24.6. 30-DAY OBSERVATION PERIOD ..... 100

24.7. FINAL ACCEPTANCE ..... 101

24.8. MEASUREMENT AND PAYMENT ..... 101

## 1. GENERAL REQUIREMENTS

### 1.1.DESCRPTION

#### A. General

Conform to these Project Special Provisions, Project Plans, and the *2012 Standard Specifications for Roads and Structures* (also referred to hereinafter as the “Standard Specifications”). The current edition of these specifications and publications in effect on the date of advertisement will apply.

In the event of a conflict between these Project Special Provisions and the Standard Specifications, these Project Special Provisions govern.

#### B. Scope

The scope of this project includes the installation of new fiber optic cable communications, two (2) new pedestal mount dynamic message signs (DMS) and two (2) new closed circuit television (CCTV) cameras. New fiber optic cables will be installed in new underground conduit and on new aerial messenger cable. New electrical service will be installed at each device site. The Contractor shall coordinate with the Engineer and the appropriate electric utility company in the area to establish service.

Note that the locations of each proposed device shown in the Plans are an approximation. Locate and mark proposed device locations in the field and receive approval from the Regional ITS Engineer before beginning construction.

Integrate the new fiber optic cables with existing fiber optic cables installed under project U-2579B so that the new DMS and CCTV devices are accessible and controlled by the existing computer and network hardware and software at the NCDOT Triad Regional Transportation Management Center (TRTMC) located at 201 South Chimney Rock Road in Greensboro.

Conduct device and system tests as described in these Project Special Provisions.

#### C. 2012 Standard Specifications for Roads and Structures

The 2012 Standard Specifications are revised as follows:

##### *Polymer Concrete (PC) Junction Boxes (1091-5(B))*

Page 10-202, revise paragraph starting on line 9 to read “Provide polymer concrete (PC) boxes which have bolted covers and open bottoms. Provide vertical extensions of 6" to 12" as required by project special provisions.”

Page 10-202, revise sentence beginning on line 14 to read “Other thermoplastic materials may be used for components which are not normally exposed to sunlight.”

##### *Submittal Requirements (1098-1(B))*

Page 10-208, replace paragraph on line 34 with the following:

Submit for approval catalog cuts and/or shop drawings for materials proposed for use on the project. Allow 40 days for review of each submittal. Do not fabricate or order material until receipt of Engineer’s approval.

Submit 4 copies of each catalog cut and/or drawing and show for each component the material description, brand name, stock-number, size, rating, manufacturing specification and the intended

use (identified by labeling all components with the corresponding contract line item number). Present the submittals neatly arranged in the same order as the contract bid items. Electronic submittals of catalog cuts and drawings may be accepted in lieu of hard copies.

One hard copy and an electronic (PDF) copy of reviewed submittals will be returned to the Engineer from the ITS and Signals Unit.

## **1.2.MATERIAL**

### **A. Qualified Products**

Furnish new equipment, materials, and hardware unless otherwise required. Inscribe manufacturer's name, model number, serial number, and any additional information needed for proper identification on each piece of equipment housed in a case or housing.

Furnish factory assembled cables without adapters, unless otherwise approved by the Engineer, for all cables required to interconnect any field or central equipment.

Certain equipment listed in these Project Special Provisions must be pre-approved on the Department's ITS & Signals Qualified Products List (QPL) by the date of installation. Equipment, material, and hardware not pre-approved when required will not be allowed for use on the project.

The QPL is available on the Department's website. The QPL website is:

<https://connect.ncdot.gov/resources/safety/Pages/ITS-and-Signals-Qualified-Products.aspx>

### **B. Plan of Record Documentation**

Comply with all requirements of Article 1098-1(F) of the Standard Specifications for providing plan of record documentation for all work performed under this Project. Documentation required includes, but is not limited to, the following items:

- Fieldwork plan of records
- Junction box location spreadsheet
- System connection diagrams
- OTDR test results
- Splicing workmanship photos
- Cabinet wiring diagrams
- Equipment operator manuals
- Maintenance procedures manuals



## 2. UNDERGROUND CONDUIT

### 2.1.DESCRPTION

Furnish and install conduit for underground installation with tracer wire, miscellaneous fittings, all necessary hardware, marker tape, backfill, graded stone, paving materials, and seeding and mulching in accordance with Section 1715 of the Standard Specifications.

### 2.2.MATERIAL

Material, equipment, and hardware furnished under this section shall be pre-approved on the Department's QPL.

Refer to Articles 1091-3 (Conduit), 1091-4 (Duct and Conduit Sealer), 1018-2 (Backfill), and 545-2 and 545-3 (Graded Stone) of the Standard Specifications.

Furnish underground HDPE conduits as shown in the Plans. All vertical conduits (entrance to electrical service and equipment disconnect and pole mounted cabinet) must be rigid galvanized steel.

### 2.3.CONSTRUCTION METHODS

Install underground conduit in compliance with all requirements of Section 1715-3 of the Standard Specifications and the Plans.

### 2.4.MEASUREMENT AND PAYMENT

*Tracer wire* will be measured along the horizontal linear feet of tracer wire furnished, installed, and accepted. Measurement will be along the approximate centerline of the conduit system. Payment will be made in linear feet. No payment will be made for excess tracer wire in junction boxes and/or cabinets.

*Unpaved Trenching (qty) (size)* will be measured horizontal linear feet of trenching for underground conduit installation of each type furnished, installed, and accepted. Measurement will be along the approximate centerline of the conduit system. Payment will be in linear feet.

*Directional Drill (qty) (size)* will be measured horizontal linear feet of directional drill for underground conduit installation furnished, installed, and accepted. Measurement will be along the approximate centerline of the conduit system. Payment will be in linear feet.

No measurement will be made of vertical segments, non-metallic conduit, metallic conduit, conduit sealing material, backfill, graded stone, paved materials, miscellaneous fittings, non-detectable marker tape, pull lines, seeding, and mulching as these will be considered incidental to conduit installation.

Payment will be made under:

<b>Pay Item</b>	<b>Pay Unit</b>
Tracer Wire .....	Linear Foot
Unpaved Trenching (3) (2").....	Linear Foot
Unpaved Trenching (2) (2").....	Linear Foot
Directional Drill (4) (2") .....	Linear Foot
Directional Drill (2) (2") .....	Linear Foot

**3. JUNCTION BOXES**

**3.1.DESCRPTION**

Furnish and install junction boxes (pull boxes) with covers, graded stone, grounding systems, and all necessary hardware in accordance with Section 1716 of the Standard Specifications.

**3.2.MATERIAL**

Material, equipment, and hardware furnished under this section shall be pre-approved on the Department's QPL.

Refer to Article 1098-5 (Junction Boxes) and Section 545 (Graded Stone) of the Standard Specifications.

Provide covers engraved with "NCDOT FIBER OPTIC CABLE" on the top face.

**3.3.CONSTRUCTION METHODS**

Install junction boxes in compliance with all requirements of Section 1716-3 of the Standard Specifications.

Install over-sized heavy-duty junction boxes with minimum inside dimensions of 30" x 15" (length x width) for storage of fiber optic communications cables.

Install special over-sized heavy-duty junction boxes with minimum inside dimensions of 36" x 24" (length x width) for underground splice enclosures.

**3.4.MEASUREMENT AND PAYMENT**

*Junction Box* (\_\_\_\_) will be measured and paid in actual number of junction boxes of each size and type furnished, installed, and accepted.

No measurement will be made of covers, graded stone, and grounding systems as these will be considered incidental to furnishing and installing junction boxes.

Payment will be made under:

<b>Pay Item</b>	<b>Pay Unit</b>
Junction Box (Standard Size).....	Each
Junction Box (Over-sized, Heavy Duty).....	Each
Junction Box (Special Over-sized, Heavy Duty).....	Each

**4. WOOD POLES**

**4.1.DESCRPTION**

Furnish and install wood poles with grounding systems and all necessary hardware in accordance with Section 1720 of the Standard Specifications.

**4.2.MATERIAL**

**A. General**

Material, equipment, and hardware furnished under this section shall be pre-approved on the Department's QPL.

Refer to Articles 1082-3 (Treated Timber and Lumber), 1082-4 (Preservative Treatment), 1091-2 (Wire), and 1091-6 (Grounding Electrodes) of the Standard Specifications.

**B. Wood Pedestal**

Furnish 6" x 6" x 8' wood pedestals for electrical service equipment as shown in the Plans.

**C. Wood Pole**

Furnish 40' Class 4 or better wood poles for attaching messenger cable and communications cable or for mounting electrical service equipment as shown in the Plans.

**4.3.CONSTRUCTION METHOD**

Install wood poles and wood posts in compliance with all requirements of Section 1720-3 of the Standard Specifications.

**4.4.MEASUREMENT AND PAYMENT**

*Wood Pedestal* will be measured and paid as the actual number of 8' wood pedestals furnished, installed, and accepted.

*Wood Pole* will be measured and paid as the actual number of 40' wood poles furnished, installed, and accepted.

No measurement will be made for installing grounding systems as these will be incidental to furnishing and installing poles.

Payment will be made under:

<b>Pay Item</b>	<b>Pay Unit</b>
Wood Pedestal .....	Each
Wood Pole.....	Each

**5. RISER ASSEMBLIES**

**5.1.DESCRPTION**

Furnish and install riser assemblies with clamp-on, aluminum weatherheads or heat shrink tubing, galvanized pole attachment fittings and all necessary hardware in accordance with Section 1722 of the Standard Specifications.

**5.2.MATERIAL**

Material, equipment, and hardware furnished under this section shall be pre-approved on the Department's QPL.

Refer to 1091-2 (Wire), 1091-3 (Rigid Metallic Conduit), 1091-6 (Grounding Electrodes), 1098-4 (Riser Sealing Devices), and 1098-6 (Pole Line Hardware) of the Standard Specifications.

**5.3.CONSTRUCTION METHOD**

Install riser assemblies in compliance with all requirements of Section 1722-3 of the Standard Specifications.

**5.4.MEASUREMENT AND PAYMENT**

\_\_\_" *Riser with* \_\_\_\_\_ will be measured and paid as the actual number of risers of each type and size furnished, installed and accepted. No measurement will be made of weatherheads, heat shrink tubing or pole attachment fittings as these will be incidental to furnishing and installing risers.

Payment will be made under:

<b>Pay Item</b>	<b>Pay Unit</b>
2" Riser with Heat Shrink Tubing .....	Each

**6. GUY ASSEMBLIES**

**6.1.DESCRPTION**

Furnish and install guy assemblies with all necessary hardware in accordance with Section 1721 of the Standard Specifications.

**6.2.MATERIAL**

Material, equipment, and hardware furnished under this section shall be pre-approved on the Department's QPL.

Refer to 1098-6 (Pole Line Hardware) and 1098-7 (Guy Assembly) of the Standard Specifications.

**6.3.CONSTRUCTION METHOD**

When installing messenger cable for supporting only communications cable, use approved one-bolt attachment method for attaching messenger cable and guy assembly.

Bond guy assembly to existing pole ground using parallel groove clamp or equivalent. If existing poles do not have a grounding system, install new grounding system for bonding guy assembly that complies with Article 1720-3.

Do not attach to existing guy assemblies unless specifically approved by owner.

**6.4.MEASUREMENT AND PAYMENT**

*Guy Assembly* will be measured and paid as the actual number of guy assemblies furnished, installed, and accepted.

No measurement will be made of guy cable, guy guards, anchors, clamps, grounding systems or fittings as these will be incidental to furnishing and installing guy assemblies.

Payment will be made under:

<b>Pay Item</b>	<b>Pay Unit</b>
Guy Assembly.....	Each

**7. MESSENGER CABLE**

**7.1.DESCRPTION**

Furnish and install messenger cable (spanwire) with cable clamps, machine bolts, eye bolts, 3-bolt clamps, eye nuts, split-bolt connectors, and all necessary hardware in accordance with Section 1710 of the Standard Specifications.

**7.2.MATERIAL**

Material, equipment, and hardware furnished under this section shall be pre-approved on the Department's QPL.

Refer to 1091-2 (Wire), 1091-6 (Grounding Electrode), 1098-3 (Messenger Cable), and 1098-6 (Pole Line Hardware) of the Standard Specifications.

**7.3.CONSTRUCTION METHOD**

Comply with Section 1710-3 of the Standard Specifications.

**7.4.MEASUREMENT AND PAYMENT**

*Messenger Cable* (\_\_\_\_) will be measured and paid as actual horizontal linear feet of messenger cable furnished, installed, and accepted. Measurement will be point to point with no allowance for sag.

No measurement will be made of cable clamps, machine bolts, eye bolts, 3-bolt assemblies, eye nuts, split bolt connectors and pole grounding systems as these will be incidental to furnishing and installing messenger cable.

Payment will be made under:

<b>Pay Item</b>	<b>Pay Unit</b>
Messenger Cable (1/4") .....	Linear Foot

**8. FIBER-OPTIC CABLE**

**8.1.DESCRPTION**

Furnish and install single mode fiber-optic (SMFO) communications cable and drop cable assemblies with grounding systems, fiber-optic cable storage racks (snow shoes), communications cable identification markers, lashing wire, and all necessary hardware in accordance with Section 1730 of the Standard Specifications.

**8.2.MATERIAL**

Furnish material, equipment, and hardware under this section that is pre-approved on the Department’s QPL.

Refer to Articles 1098-10(A) (SMFO Communications Cable), 1098-10(C) (Communications Cable Identification Markers), 1098-10(D) (Fiber-Optic Cable Storage Guides), and 1098-6 (Pole Line Hardware) of the Standard Specifications.

Provide communications cable identification markers with 336-315-7080 as the contact telephone number.

**8.3.CONSTRUCTION METHODS**

Install fiber-optic cable in compliance with all requirements of Section 1730-3 of the Standard Specifications.

Do not install any communications cables in the same conduit or junction box as power cables.

Store 30 feet of each fiber optic cable entering a junction box. Store 100 feet of each fiber optic cable being spliced in an underground splice enclosure located in a junction box. Coil all stored cable in the bottom of the junction box and in a manner that does not violate the maximum bending radius of the cable.

**8.4.MEASUREMENT AND PAYMENT**

*Communications cable* (\_\_\_\_-fiber) will be measured and paid as the actual linear feet of fiber-optic cable of each fiber count furnished, installed, and accepted. Measurement will be made by calculating the difference in length markings located on outer jacket from start of run to end of run for each run. Terminate all fibers before determining length of cable run.

*Drop Cable* will be measured and paid as linear feet of fiber-optic drop cable (12-fiber) assemblies furnished, installed, and accepted. Sag and vertical segments will not be paid as these distances are incidental to the installation of drop cable assemblies.

No measurement will be made for terminating, splicing, and testing fiber-optic cable, communications cable identification markers, or fiber-optic cable storage racks, as these will be considered incidental to the installation of fiber-optic cable.

Payment will be made under:

<b>Pay Item</b>	<b>Pay Unit</b>
Communications Cable (72-Fiber) .....	Linear Foot
Drop Cable .....	Linear Foot



**9. DELINEATOR MARKERS**

**9.1.DESCRPTION**

Furnish and install delineator markers with all necessary hardware in accordance with Section 1733 of the Standard Specifications.

**9.2.MATERIALS**

Material, equipment, and hardware furnished under this section shall be pre-approved on the Department's QPL. Refer to Article 1098-13 (Delineator Markers) of the Standard Specifications.

Provide delineator markers with 336-315-7080 as the contact telephone number.

**9.3.CONSTRUCTION METHODS**

Install delineator markers in compliance with all requirements of Section 1733-3 of the Standard Specifications.

**9.4.MEASUREMENT AND PAYMENT**

Delineator marker will be paid for by the actual number furnished, installed, and accepted.

Payment will be made under:

<b>Pay Item</b>	<b>Pay Unit</b>
Delineator Marker .....	Each

**10. FIBER-OPTIC SPLICE CENTERS**

**10.1. DESCRIPTION**

Furnish and install fiber-optic interconnect centers, fiber-optic splice enclosures, and all necessary hardware in accordance with Section 1731 of the Standard Specifications.

Modify existing fiber optic interconnect centers and/or splice enclosures as shown in the plans. Refer to manufacturer’s recommendations for opening, modifying and re-sealing the existing fiber optic interconnect center and/or fiber optic splice enclosures.

**10.2. MATERIALS**

Material, equipment, and hardware furnished under this section shall be pre-approved on the Department’s QPL.

Refer to Article 1098-11 (Fiber-Optic Splice Centers) of the Standard Specifications.

**10.3. CONSTRUCTION METHODS**

Install fiber-optic splice centers, perform termination and splicing, and test in compliance with all requirements of Section 1731-3 of the Standard Specifications.

Install all new fiber optic cables and drop cables and perform all splicing required at new splice enclosures prior to modifying the existing splice enclosure.

**10.4. MEASUREMENT AND PAYMENT**

*Interconnect center* will be measured and paid as the actual number of fiber-optic interconnect centers furnished, installed, and accepted.

*Splice enclosure* will be measured and paid as the actual number of fiber-optic splice enclosures furnished, installed, and accepted. No measurement will be made between aerial, underground, manhole, or junction box installation of the fiber-optic splice enclosure.

*Modify splice enclosure* will be measured and paid as the actual number of fiber-optic splice enclosures modified and accepted. No measurement will be made between aerial, underground, manhole or junction box installation of the fiber-optic splice enclosure.

No measurement will be made of splice trays, pigtails, jumpers, connector panels, testing and any corrective actions, repairs and replacements needed for exceeding maximum allowable attenuation or other defects, as these will be considered incidental to furnishing and installing fiber-optic interconnect centers and splice enclosures and modifying splice enclosures.

Payment will be made under:

<b>Pay Item</b>	<b>Pay Unit</b>
Interconnect Center .....	Each
Splice Enclosure.....	Each
Modify Splice Enclosure.....	Each

**11. SPLICE CABINET (FIBER OPTICS)**

**11.1. DESCRIPTION**

Furnish and install splice cabinets and all necessary hardware in accordance with the plans and specifications for splicing and terminating fiber-optic cable.

**11.2. MATERIALS**

Furnish NEMA Type 4 splice cabinets of sufficient size to accommodate the fiber-optic interconnect center. Provide sufficient size so that the equipment installed will not occupy more than 60 percent of the total cabinet volume.

**11.3. CONSTRUCTION METHODS**

Locate cabinets so as not to obstruct sight distance of vehicles turning on red.

Install base mounted cabinets as shown on the plans and as approved by the Engineer. Refer to Section 1750 - Signal Cabinet Foundations of the Standard Specifications for installation requirements for the foundations. The following exceptions are made:

- Install only the required number of conduits as shown on the plans plus one additional spare stub out conduit.
- Do not provide a 24-inch working area on the backside of the cabinet. Provide only a 24-inch working area measured from the front of the cabinet and 3-inch lip measured from the sides and back of the cabinet.
- All other requirements apply.

**11.4. MEASUREMENT AND PAYMENT**

*Fiber-optic splice cabinets* will be measured and paid as the actual number of base-mounted splice cabinets furnished, installed, and accepted.

No measurement will be made for the cabinet foundation as it will be covered under the Equipment Cabinet Foundations section of these Project Special Provisions.

Payment will be made under:

<b>Pay Item</b>	<b>Pay Unit</b>
Fiber-Optic Splice Cabinet .....	Each

**12. EQUIPMENT CABINET FOUNDATIONS**

**12.1. DESCRIPTION**

Furnish and install cabinet foundations for fiber optic splice cabinets and all necessary hardware in accordance with Section 1750 of the Standard Specifications.

Furnish either poured concrete foundations or preformed cabinet pad foundations and all necessary hardware. Obtain approval of foundation type.

**12.2. MATERIAL**

Furnish preformed cabinet pad foundation material, equipment and hardware under this section that is pre-approved on the ITS and Signals QPL.

Refer to Articles 100-4 (Portland Cement Concrete) and 1098-15 (Signal Cabinet Foundation) of the Standard Specifications.

**12.3. CONSTRUCTION METHODS**

Install equipment cabinet foundations for fiber optic splice cabinets in compliance with all requirements of Section 1750-3 of the Standard Specifications.

**12.4. MEASUREMENT AND PAYMENT**

*Equipment Cabinet Foundation* will be measured and paid as the actual number of foundations for fiber optic splice cabinets furnished, installed, and accepted.

Payment will be made under:

<b>Pay Item</b>	<b>Pay Unit</b>
Equipment Cabinet Foundation .....	Each

### 13. ELECTRICAL SERVICE

#### 13.1. DESCRIPTION

Install new electrical service equipment as shown in the Plans. The first item of work on this project is the installation of all electrical service poles and meter base/disconnect combination panels to expedite the power service connections. Comply with the National Electrical Code (NEC), the National Electrical Safety Code (NESC), the Standard Specifications, the Project Special Provisions, and all local ordinances. All work involving electrical service shall be coordinated with the appropriate utility company and the Engineer.

#### 13.2. MATERIAL

##### A. Meter Base/Disconnect Combination Panel

Furnish and install new meter base/disconnect combination panels as shown in the Plans. Provide meter base/disconnect combination panels that have a minimum of four (4) spaces in the disconnect. Furnish single pole 15A circuit breakers for CCTV devices and double pole 50A circuit breakers for DMS devices. Furnish each with a minimum of 10,000 RMS symmetrical amperes short circuit current rating in a lockable NEMA 3R enclosure. Ensure meter base/ disconnect combination panel is listed as meeting UL Standard UL-67 and marked as being suitable for use as service equipment. Ensure circuit breakers are listed as meeting UL-489. Fabricate enclosure from galvanized steel and electrostatically apply dry powder paint finish, light gray in color, to yield a minimum thickness of 2.4 mils. All exterior surfaces must be powder coated steel. Provide ground bus and neutral bus with a minimum of four terminals and a minimum wire capacity range of number 12 through number 3 AWG.

Furnish NEMA Type 3R meter base rated 100A minimum for overhead service and 200A minimum for underground service and that meets the requirements of the local utility. Provide meter base with sockets' ampere rating based on sockets being wired with a minimum of 167 degrees F insulated wire. Furnish 4 terminal, 600 volt, single phase, 3-wire meter bases that comply with the following:

- Line, Load, and Neutral Terminals accept 4/0 AWG and smaller Copper/Aluminum wire
- With or without horn bypass
- Made of galvanized steel
- Listed as meeting UL Standard US-414
- Overhead or underground service entrance specified.

Furnish 1.25" watertight hub for threaded rigid conduit with meter base.

At the main service disconnect, furnish, and install UL-approved lightning arrestors that meet the following requirements:

Type of design	Silicon Oxide Varistor
Voltage	120/240 Single Phase, 3 wire
Maximum current	100,000 amps
Maximum energy	3000 joules per pole
Maximum number of surges	Unlimited
Response time one milliamp test	5 nanoseconds
Response time to clamp 10,000 amps	10 nanoseconds
Response time to clamp 50,000 amps	25 nanoseconds
Leak current at double the rated voltage	None
Ground wire	Separate

### **B. Equipment Cabinet Disconnect**

Provide new equipment cabinet disconnects at the locations shown in the Plans. Furnish double pole 50A circuit breakers at DMS locations. Furnish single pole 15A circuit breaker at CCTV locations. Furnish panels that have a minimum of four (4) spaces in the disconnect. Furnish circuit breakers with a minimum of 10,000 RMS symmetrical amperes short circuit current rating in a lockable NEMA 3R enclosure. Ensure meter base/ disconnect combination panel is listed as meeting UL Standard UL-67 and marked as being suitable for use as service equipment. Ensure circuit breakers are listed as meeting UL-489. Fabricate enclosure from galvanized steel and electrostatically apply dry powder paint finish, light gray in color, to yield a minimum thickness of 2.4 mils. All exterior surfaces must be powder coated steel. Provide ground bus and neutral bus with a minimum of four terminals and a minimum wire capacity range of number 12 through number 3 AWG.

### **C. 4-Wire Copper Feeder Conductors**

Furnish 4-wire stranded copper feeder conductors with THWN rating for supplying power to DMS field equipment cabinets. Provide conductors with black, red, white, and green insulation that are intended for power circuits at 600 Volts or less and comply with the following:

- Listed as meeting UL Standard UL-83
- Meets ASTM B-3 and B-8 or B-787 standards.

See the Plans for wire sizes and quantities.

### **D. 3-Wire Copper Feeder Conductors**

Furnish 3-wire stranded copper feeder conductors with THWN rating for supplying power to CCTV field equipment cabinets. Provide conductors with black or red, white, and green insulation that are intended for power circuits at 600 Volts or less and comply with the following:

- Listed as meeting UL Standard UL-83
- Meets ASTM B-3 and B-8 or B-787 standards.

See the Plans for wire sizes and quantities.

**E. Grounding System**

Furnish 5/8"x10' copper clad steel grounding electrodes (ground rods), #4 AWG solid bare copper conductors, and exothermic welding kits for grounding system installations. Comply with the NEC, Standard Specifications, these Project Special Provisions, and the Plans.

**13.3. CONSTRUCTION METHODS****A. General**

Permanently label cables at all access points using nylon tags labeled with permanent ink. Ensure each cable has a unique identifier. Label cables immediately upon installation. Use component name and labeling scheme approved by the Engineer.

**B. Meter Base/Disconnect Combination Panel**

Install meter base/disconnect combination panels with lightning arrestors as called for in the Plans. Route the feeder conductors from the meter base/disconnect to the equipment cabinet in conduit. Provide rigid galvanized conduit for above ground and PVC for below ground installations.

**C. Electrical Service Disconnect**

Install equipment cabinet disconnects and circuit breakers as called for in the Plans. Install THWN stranded copper feeder conductors as shown in Plans between the electrical service disconnect and the equipment cabinet disconnect. Route the conductors from the equipment cabinet disconnect to the equipment cabinet in rigid galvanized steel conduit. Bond the equipment cabinet disconnect in accordance with the NEC. Ensure that the grounding system complies with the grounding requirements of these Project Special Provisions, the Standard Specifications, and the Plans.

**D. 4-Wire Copper Feeder Conductors**

At locations shown in the Plans, install 4-wire THWN stranded copper feeder conductors to supply 240/120 VAC to the DMS field equipment cabinets. Size the conductors as specified in the Plans. Comply with the Standard Specifications and Standard Drawings and all applicable electrical codes.

**E. 3-Wire Copper Feeder Conductors**

At locations shown in the Plans, install 3-wire THWN stranded copper feeder conductors to supply 120 VAC to the CCTV field equipment cabinets. Size the conductors as specified in the Plans. Comply with the Standard Specifications and Standard Drawings and all applicable electrical codes.

**F. Grounding System**

Install ground rods as indicated in the Plans. Connect the #4 AWG grounding conductor to ground rods using an exothermic welding process. Test the system to ensure a ground resistance of 20-ohms or less is achieved. Drive additional ground rods as necessary or as directed by the Engineer to achieve the proper ground resistance.

**13.4. MEASUREMENT AND PAYMENT**

*Meter base/disconnect combination panel* will be measured and paid as the actual number of complete and functional meter base/disconnect combination panel service locations furnished,

installed, and accepted. Breakers, lightning arrestors, exposed vertical conduit runs to the cabinet, and any remaining hardware, fittings, and conduit bodies to connect the electrical service to the cabinet will be considered incidental to meter base/disconnect combination panels. All other required feeder conductors will be paid for separately.

*Equipment cabinet disconnect* will be measured and paid as the actual number of complete and functional equipment cabinet disconnects furnished, installed, and accepted. Breakers, exposed vertical conduit runs to the cabinet, ground rods, ground wire and any remaining hardware and conduit to connect the equipment cabinet disconnect to the cabinet will be considered incidental to the equipment cabinet subpanel.

*4-Wire copper feeder conductors* will be measured and paid as the actual linear feet of 4-wire THWN stranded copper feeder conductors furnished, installed, and accepted. Payment is for all four conductors. Measurement will be for the actual linear footage of combined conductors after all terminations are complete. No separate payment will be made for each individual conductor. No separate payment will be made for different wire sizes. No payment will be made for excess wire in the cabinets.

*3-Wire copper feeder conductors* will be measured and paid as the actual linear feet of 3-wire THWN stranded copper feeder conductors furnished, installed, and accepted. Payment is for all three conductors. Measurement will be for the actual linear footage of combined conductors after all terminations are complete. No separate payment will be made for each individual conductor. No separate payment will be made for different wire sizes. No payment will be made for excess wire in the cabinets.

*5/8" X 10' grounding electrode* (ground rod) will be measured and paid as the actual number of 5/8" copper clad steel ground rods furnished, installed and accepted. No separate payment will be made for exothermic welding kit as they will be considered incidental to the installation of the ground rod.

*#4 solid bare grounding conductor* will be measured and paid as the actual linear feet of #4 AWG solid bare copper grounding conductor furnished, installed, and accepted. Measurement will be along the approximate centerline from the base of the electrical service disconnect to the last grounding electrode.

Payment will be made under:

<b>Pay Item</b>	<b>Pay Unit</b>
Meter Base/Disconnect Combination Panel .....	Each
Equipment Cabinet Disconnect.....	Each
4-Wire Copper Feeder Conductors .....	Linear Foot
3-Wire Copper Feeder Conductors .....	Linear Foot
5/8" X 10' Grounding Electrode.....	Each
#4 Solid Bare Grounding Conductor .....	Linear Foot



## 14. CCTV CAMERA EQUIPMENT

### 14.1. DESCRIPTION

Furnish and install High Definition (720p) CCTV field equipment described in these Project Special Provisions. Ensure equipment is fully compatible with all features of the existing *VideoPro* video management software currently in use by NCDOT in this Region.

Contact the Regional ITS Engineer to confirm all CCTV locations prior to beginning construction.

### 14.2. MATERIAL

#### A. General

Furnish and install new CCTV camera assemblies at the locations shown on the Plans that consist of the following:

- Dome CCTV camera that contains in a single enclosed unit the following:
  - CCTV color digital signal processing camera unit with zoom lens, filter, control circuit, and accessories
  - Motorized pan, tilt, and zoom
  - Pole-mount camera attachment assembly.
  - Built-in video encoder capable of H.264/MPEG-4 compression for video-over-IP transmission.
  - All necessary cable, connectors, and incidental hardware to make a complete and operable system
- Lightning arrestors installed in-line between the CCTV camera and the equipment cabinet components.
- A NEMA Type 4 enclosure constructed of aluminum with a clear acrylic dome or approved equal camera unit housing.

#### B. Camera and Lens

##### 1. Cameras

Furnish new Complementary Metal-Oxide-Semiconductor (CMOS) sensor-equipped color cameras. Furnish cameras that meet the following minimum requirements:

- Video format: NTSC compatible resolution, user selectable up to a maximum of 1280x720 (720p)
- Focus: Automatic with manual override, Electronic Image Stabilization (EIS)
- White balance: Automatic through the lens with manual override
- Shutter: Electronic shutter with manual control from 1/2 of a second to 1/30,000th of a second
- Overexposure protection: The camera must have built-in circuitry or a protection device to prevent any damage to the camera when pointed at strong light sources, including the sun

- Sensitivity: 0.6 lux at 90% scene reflectance
- Input/Output Connection: Single 10BASE-T/100BASE-T compatible outdoor-rated Cat5e cable for video, control, and Power over Ethernet; IP66-rated RJ45 connector
- Power: High Power over Ethernet (High PoE), 74W max

## **2. Zoom Lens**

Furnish each camera with a motorized zoom lens that is integrated in a high-performance dome system, or approved equivalent, with automatic iris control and manual override. Furnish lenses that meet the following optical specifications:

- Aperture: f/1.6 – f/2.9
- Focal length: 4.45 mm (wide) and 89 mm (tele.), minimum
- Horizontal viewing angle: 55.4° (wide) and 2.9° (tele), minimum
- Zoom: 30X optical, 12X digital, minimum
- Preset positioning: 64 Presets, minimum

The lens must be capable of both automatic and remote manual control iris and focus override operation. The lens must be equipped for remote control of zoom and focus, including automatic movement to any of the preset zoom and focus positions. Provide mechanical or electrical means to protect the motors from overrunning in extreme positions. The operating voltages of the lens must be compatible with the outputs of the camera control.

### **C. Camera Housing**

Furnish new dome style enclosures for the CCTV assemblies. Equip housing with mounting assemblies for attachment to the pole mount. For CCTV locations requiring a CCTV lowering system, equip each housing with a mounting assembly for attachment to the CCTV lowering system. The enclosures must be equipped with a sunshield and be fabricated from corrosion resistant aluminum and finished in a neutral color of weather resistant enamel. The enclosure must meet or exceed NEMA 4X ratings. The viewing area of the enclosure must be tempered glass.

### **D. Pan and Tilt Unit**

Equip each new dome style assembly with a pan and tilt unit. The pan and tilt unit must be integral to dome system. The pan and tilt unit must be rated for outdoor operation, provide dynamic braking for instantaneous stopping, prevent drift, and have minimum backlash. The dome must have an auto flip dome rotation to rotate and reposition camera for viewing objects passing below camera. Provide electronic image stabilization. The pan and tilt units must meet or exceed the following specifications:

- Pan: Continuous 360 degrees
- Tilt: +2 to -92 degrees minimum
- Presets: Minimum of 128 presets
- Preset accuracy: .1 degree
- Preset pan speed: .1 degrees/second to 200 degrees/second
- Preset tilt speed: .1 degrees/second to 400 degrees/second

- Privacy zones: Minimum of eight user configurable shapes
- Input voltage: 24 VDC or 24 VAC
- Motors: Two-phase induction type, continuous duty, instantaneous reversing
- Preset Positioning: 64 PTZ presets per camera

#### **E. Video Ethernet Encoder**

Furnish cameras with a built-in digital video Ethernet encoder to allow video-over-IP transmission. The encoder units must be built into the camera housing and require no additional equipment to transmit encoded video over IP networks.

Encoders must have the following minimum features:

- Network Interface: Ethernet 10/100Base-T (RJ-45 connector)
- Protocols: IPv4, IPv6, HTTP, HTTPS, SSL, QoS, FTP, SMTP, UPnP, SNMP v2c/v3, DNS, NTP, RTSP, RTP, TCP, UDP, IGMP, and DHCP
- Security: SSL, SSH, 802.1x, HTTPS encryption with password controlled browser interface
- Video Streams: 2 simultaneous streams, user configurable
- Compression: H.264 (MPEG-4 Part 10/AVC)
- Resolution: Scalable; NTSC-compatible 320x176 to 1920x1080 (HDTV 1080p, 16:9 aspect ratio)
- Frame Rate: 1-30 FPS programmable (full motion)
- Bandwidth: 30 kbps – 6 Mbps, configurable depending on resolution
- Edge Storage: SD/SDHC/SDXC slot supporting up to 64GB memory card

#### **F. Control Receiver/Driver**

Provide each new camera unit with a control receiver/driver that is integral to the CCTV dome assembly. The control receiver/driver will receive serial asynchronous data initiated from a camera control unit, decode the command data, perform error checking, and drive the pan/tilt unit, camera controls, and motorized lens. As a minimum, the control receiver/drivers must provide the following functions:

- Zoom in/out
- Automatic focus with manual override
- Tilt up/down
- Automatic iris with manual override
- Pan right/left
- Minimum 64 preset positions for pan, tilt, and zoom

In addition, each control receiver/driver must accept status information from the pan/tilt unit and motorized lens for preset positioning of those components. The control receiver/driver will relay pan, tilt, zoom, and focus positions from the field to the remote camera control unit. The control

receiver/driver must accept “goto” preset commands from the camera control unit, decode the command data, perform error checking, and drive the pan/tilt and motorized zoom lens to the correct preset position. The preset commands from the camera control unit will consist of unique values for the desired pan, tilt, zoom, and focus positions.

#### **G. Ethernet Cable**

Provide, at a minimum, Category 5 Enhanced (5e) Ethernet cable that complies with ANSI/TIA-568-B-5 standards for 4-pair shielded twisted copper for Ethernet communications. The cable shall meet all of the mechanical requirements of ANSI/ECEA S-80-576. The Ethernet cable must be rated for medium-power, network-powered broadband communications circuits and must be Type BMU network-powered broadband communications medium-power cable.

Provide 4-pair twisted copper Ethernet cable and connectors rated for an ambient operating temperature range of -30° F to 165° F. The cable shall be shielded, outdoor-rated, and have a UV-resistant jacket. The void between the insulated copper pairs and the polyethylene outer jacket shall be injected with a water-resistant flooding compound.

#### **H. CCTV Camera Attachment to Pole**

Furnish CCTV attachments that allow for the removal and replacement of the CCTV enclosure as well as providing a weatherproof, weather tight, seal that does not allow moisture to enter the enclosure.

Furnish a CCTV camera attachment assembly that can withstand wind loading at the maximum wind speed and gust factor called for in these Special Provisions and can support a minimum camera unit dead load of 45 pounds.

#### **I. Surge Suppression**

Protect all equipment with metal oxide varistors connecting each power conductor to ground.

Protect coaxial cable from each camera by a surge protector at each end of the cable.

### **14.3. CONSTRUCTION METHODS**

#### **A. General**

Furnish all tools, equipment, materials, supplies, and hardware necessary to install a fully operational CCTV camera system as depicted in the Plans.

Mount CCTV camera units at a height sufficient to adequately see traffic in all directions and as approved by the Engineer. The maximum attachment height is 45 feet above ground level.

Mount the CCTV camera units such that a minimum 5 feet of clearance is maintained between the camera and the top of the pole.

Obtain approval of the camera locations and orientation from the Engineer prior to installing the CCTV camera assemblies.

Mount CCTV cameras on the side of poles nearest intended field of view. Avoid occluding the view with the pole.

#### **B. Electrical and Mechanical Requirements**

Install Power over Ethernet (PoE) injector in CCTV equipment cabinet, and run an outdoor-rated Cat5e Ethernet cable up the interior of the steel pole to the CCTV assembly. Take all precautions necessary to ensure the Ethernet cable is not damaged during storage and installation. Do not step

on the cable nor run over the cable with vehicles or equipment. Do not pull the cable over or around obstructions or along the ground. Install the cables according to the latest version of the manufacturer’s cable installation procedures and the industry-accepted installation standards, codes, and practices, or as directed by the Engineer.

Ground all equipment as called for in the Standard Specifications, these Special Provisions, and the Plans.

Install surge protectors on all ungrounded conductors entering the CCTV enclosure. House the protectors in a small, ventilated weatherproof cabinet attached near the CCTV attachment point in a manner approved by the Engineer.

Furnish all tools, equipment, materials, supplies, and hardware necessary to install a fully operational CCTV camera system as depicted in the plans.

**14.4. MEASUREMENT AND PAYMENT**

*CCTV camera assembly* will be measured and paid as the actual number of CCTV assemblies furnished, installed, integrated, and accepted. No separate measurement will be made for cabling, connectors, CCTV camera attachment assemblies, conduit, condulets, grounding equipment, surge protectors, PoE injectors, or any other equipment or labor required to install the CCTV assembly.

No separate payment will be made for Ethernet cable. Ethernet cable, furnished and installed in the quantities required, will be incidental to the “CCTV Assembly” pay item.

Payment will be made under:

<b>Pay Item</b>	<b>Pay Unit</b>
CCTV Camera Assembly .....	Each

## 15. FIELD EQUIPMENT CABINET

### 15.1. DESCRIPTION

Furnish 336 pole mounted cabinets to house CCTV control and communications equipment. The cabinets must consist of a cabinet housing, 19-inch EIA mounting cage, and power distribution assembly (PDA #3 as described in the CALTRANS TSCES).

The cabinet housing must conform to sections 6.2.2 (Housing Construction), 6.2.3 (Door Latches and Locks), 6.2.4 (Housing Ventilation), and 6.2.5 (Hinges and Door Catches) of the CALTRANS TSCES. Do not equip the cabinet housings with a police panel.

The cabinet cage must conform to section 6.3 of the CALTRANS TSCES.

Terminal blocks on the PDA #3 Assembly have internal wiring for the Model 200 switch pack sockets. Do not use terminal blocks on PDA #3 as power terminals for cabinet devices. Do not furnish cabinet with "Input Panels" described in section 6.4.7.1 of the TSCES. Do furnish cabinet with "Service Panels" as described in section 6.4.7.1 of the TSCES and as depicted on drawing TSCES-9 in the TSCES. Use service panel #2.

Furnish terminal blocks for power for cabinet CCTV and communications devices as needed to accommodate the number of devices in the cabinet.

Do not furnish cabinets with C1, C5, or C6 harness, input file, output file, monitor units, model 208 unit, model 430 unit, or switch packs.

Furnish all conduits, shelving, mounting adapters, and other equipment as necessary to route cabling, mount equipment, and terminate conduit in equipment cabinet.

### 15.2. MATERIAL

#### A. Shelf Drawer

Provide a pull out, hinged-top drawer, having sliding tracks, with lockout and quick disconnect feature, such as a Vent-Rak Retractable Writing Shelf, #D-4090-13 or equivalent in the equipment cabinet. Furnish a pullout drawer that extends a minimum of 14 inches that is capable of being lifted to gain access to the interior of the drawer. Minimum interior dimensions of the drawer are to be 1 inch high, 13 inches deep, and 16 inches wide. Provide drawers capable of supporting a 40-pound device or component when fully extended.

#### B. Cabinet Light

Each cabinet must include two (2) fluorescent lighting fixtures (one front, one back) mounted horizontally inside the top portion of the cabinet. The fixtures must include a cool white lamp, and must be operated by normal power factor UL-listed ballast. A door-actuated switch must be installed to turn on the applicable cabinet light when the front door or back door is opened. The lights must be mounted not to interfere with the upper door stay.

#### C. Surge Protection for System Equipment

Each cabinet must be provided with devices to protect the CCTV and communications equipment from electrical surges and over voltages as described below.

### 1. Main AC Power Input

Each cabinet must be provided with a hybrid-type, power line surge protection device mounted inside the power distribution assembly. The protector must be installed between the applied line voltage and earth ground. The surge protector must be capable of reducing the effect of lighting transient voltages applied to the AC line. The protector must be mounted inside the Power Distribution Assembly housing facing the rear of the cabinet. The protector must include the following features and functions:

- Maximum AC line voltage: 140 VAC.
- Twenty pulses of peak current, each of which must rise in 8 microseconds and fall in 20 microseconds to ½ the peak: 20000 Amperes.
- The protector must be provided with the following terminals:
  - Main Line (AC Line first stage terminal).
  - Main Neutral (AC Neutral input terminal).
  - Equipment Line Out (AC line second state output terminal, 19 amps).
  - Equipment Neutral Out (Neutral terminal to protected equipment).
  - GND (Earth connection).
- The Main AC line in and the Equipment Line out terminals must be separated by a 200 Microhenry (minimum) inductor rated to handle 10 AMP AC Service.
- The first stage clamp must be between Main Line and Ground terminals.
- The second stage clamp must be between Equipment Line Out and Equipment Neutral.
- The protector for the first and second stage clamp must have an MOV or similar solid state device rated at 20 KA and must be of a completely solid state design (i.e., no gas discharge tubes allowed).
- The Main Neutral and Equipment Neutral Out must be connected together internally and must have an MOV similar solid state device or gas discharge tube rated at 20 KA between Main Neutral and Ground terminals.
- Peak Clamp Voltage: 350 volts at 20 KA. (Voltage measured between Equipment Line Out and Equipment Neutral Out terminals. Current applied between Main Line and Ground Terminals with Ground and Main Neutral terminals externally tied together).
- Voltage must never exceed 350 volts.
- The Protector must be epoxy-encapsulated in a flame-retardant material.
- Continuous service current: 10 Amps at 120 VAC RMS.
- The Equipment Line Out must provide power to cabinet CCTV and communications equipment and to the 24V power supply.

### 2. Ground Bus

Provide a neutral bus that is not connected to the earth ground or the logic ground anywhere within the cabinet. Ensure that the earth ground bus and the neutral ground bus each have ten

compression type terminals, each of which can accommodate wires ranging from number 14 through number 4 AWG.

### 3. Uninterruptible Power Supply (UPS)

Furnish and install one rack mounted UPS in each new cabinet that meet the following minimum specifications:

#### Output

Output Power Capacity	480 Watts / 750 VA
Max Configurable Power	480 Watts / 750 VA
Nominal Output Voltage	120V
Output Voltage Distortion	Less than 5% at full load
Output Frequency (sync to mains)	57 - 63 Hz for 60 Hz nominal
Crest Factor	up to 5:1
Waveform Type	Sine wave
Output Connections	(4) NEMA 5-15R

#### Input

Nominal Input Voltage	120V
Input Frequency	50/60 Hz +/- 3 Hz (auto sensing)
Input Connections	NEMA 5-15P
Cord Length	6 feet
Input voltage range for main operations	82 - 144V
Input voltage adjustable range for mains operation	75 -154 V

#### Battery Type

Maintenance-free sealed Lead-Acid battery with suspended electrolyte, leak-proof.

Typical recharge time	2 hours
-----------------------	---------

#### Communications & Management

Interface Port(s)	DB-9 RS-232, USB
Control panel	LED status display with load and battery bar-graphs

#### Surge Protection and Filtering

Surge energy rating	480 Joules
---------------------	------------



**Environmental**

Operating Environment	32 - 104 °F
Operating Relative Humidity	0 - 95%
Storage Temperature	5 - 113 °F
Storage Relative Humidity	0 - 95%

**Conformance**

Regulatory Approvals	FCC Part 15 Class A, UL 1778
----------------------	------------------------------

**15.3. CONSTRUCTION METHODS**

For each equipment cabinet installation, use stainless steel banding or other method approved by the Engineer to fasten cabinet to pole. Install equipment cabinets so that the height to the middle of the enclosure is 4 feet from ground level. No risers shall enter the top or sides of the equipment cabinet.

Install all conduits, condulets, and attachments to equipment cabinets in a manner that preserves the minimum bending radius of cables and creates water proof connections and seals.

Install a UPS in each cabinet and power all CCTV cameras from the UPS.

Install a level concrete technician pad measuring a minimum 4 inches thick, 24 inches wide and 36 inches long at the front door of the CCTV equipment cabinet.

**15.4. MEASUREMENT AND PAYMENT**

*Field equipment cabinet* will be measured and paid as the actual number of field equipment cabinets furnished, installed and accepted.

No payment will be made for the UPS, cabling, connectors, cabinet attachment assemblies, conduit, condulets, risers, grounding equipment, surge protectors, or any other equipment or labor required to install the field equipment cabinet and integrate the cabinets with the CCTV and/or communications equipment.

Payment will be made under:

<b>Pay Item</b>	<b>Pay Unit</b>
Field Equipment Cabinet .....	Each

## 16. CCTV METAL POLES

### 16.1. DESCRIPTION

#### A. CCTV Metal Poles

Furnish and install CCTV metal poles, grounding systems, and all necessary hardware. The work covered by this special provision includes requirements for the design, fabrication, and installation of custom designed CCTV metal poles and associated foundations.

Provide designs of completed assemblies with hardware that equals or exceeds *AASHTO Standard Specifications for Structural Supports for Highway Signs, Luminaires and Traffic Signals* 6th Edition, 2013, including the latest interim specifications. Provide assemblies with a round or near-round (18 sides or more) cross-section, or a multi sided cross section with no less than six sides. The sides may be straight, convex, or concave.

#### B. Drilled Pier Foundations

Design, furnish and install foundations for CCTV metal poles with all necessary hardware in accordance with the plans and specifications.

Design all CCTV pole foundations using actual soil conditions at each pole location. Perform soil test in accordance with sub-section (1) Soil Test of this special provision.

Analysis procedures and formulas shall be based on AASHTO, ACI code and per FHWA manuals. Design methods based on engineering publications or research papers needs to have prior approval from NCDOT. The Department reserves the right to accept or disapprove any method used for the analysis.

Use a Factor of Safety of 1.33 for torsion and 2.0 for bending for the foundation design.

Foundation design for lateral load shall not exceed 1" lateral deflection at top of foundation.

Design all custom foundations to carry the maximum capacity of each metal pole.

When poor soil conditions are encountered which could create an excessively large foundation design, consideration may be given to allowing an exemption to the maximum capacity design. The contractor must gain approval from the engineer before reducing a foundation's capacity. On projects where poor soil is known to be present, it is advisable that the contractor consider getting foundations approved before releasing poles for fabrication.

#### C. Soil Test

##### 1. General

Drilled piers are reinforced concrete sections, cast-in-place against in situ, undisturbed material. Drilled piers are of straight shaft type and vertical.

Some standard drilled piers for supporting poles with mast arms may require wing walls to resist torsional rotation. Based upon this provision and the results of the required soil test, a drilled pier length and wing wall requirement may be determined and constructed in accordance with the plans.

For non-standard site-specific poles, the contractor-selected pole fabricator will determine if the addition of wing walls is necessary for the supporting foundations.

## 2. Soil Test:

Perform a soil test at each proposed metal pole location. Complete all required fill placement and excavation at each signal pole location to finished grade before drilling each boring. Soil tests performed that are not in compliance with this requirement may be rejected and will not be paid. Drill one boring to a depth of 26 feet within a 25 foot radius of each proposed foundation.

Perform standard penetration tests (SPT) in accordance with ASTM D 1586 at depths of 1, 2.5, 5, 7.5, 10, 15, 20 and 26 feet. Discontinue the boring if one of the following occurs:

- A total of 100 blows have been applied in any 2 consecutive 6-in. intervals.
- A total of 50 blows have been applied with < 3-in. penetration.

Describe each CCTV pole location along the project corridor in a manner that is easily discernible to both the contractor's designer and NCDOT reviewers. If a CCTV pole is at an intersection, label the boring the "Intersection of (Route or SR #), (Street Name) and (Route or SR #), (Street Name), \_\_\_\_\_ County, Signal Inventory No. \_\_\_\_\_". Label borings with "B- N, S, E, W, NE, NW, SE or SW" corresponding to the quadrant location within the intersection.

If the CCTV pole location is located between intersections, provide a coordinate location and offset, or milepost number and offset. Pole numbers should be made available to the geotechnical drilling Contractor. Include pole numbers in the boring label if they are available. If they are not available, ensure the boring labels can be cross-referenced to corresponding pole numbers or pole locations. For each boring, submit a legible (hand written or typed) boring log signed and sealed by a licensed Geologist or Professional Engineer registered in North Carolina. Include on each boring the SPT blow counts and N-values at each depth, depth of the boring, and a general description of the soil types encountered.

Borings that can't be easily related to their specific pole location will be returned to the contractor for clarification, or if approved by the engineer, the foundation may be designed using the worst case soil condition obtained as part of r this project.

## 3. Standard Foundation Determination:

Use the following method for determining the Design N-value:

$$N_{AVG} = \frac{(N@1' + N@2.5' + \dots + N@Deepest \text{ Boring Depth})}{\text{Total Number of N-values}}$$

$$Y = (N@1')^2 + (N@2.5')^2 + \dots + (N@Deepest \text{ Boring Depth})^2$$

$$Z = (N@1' + N@2.5' + \dots + N@Deepest \text{ Boring Depth})$$

$$N_{STD \text{ DEV}} = \left[ \frac{(\text{Total Number of N-values} \times Y) - Z^2}{(\text{Total Number of N-values}) \times (\text{Total Number of N-values} - 1)} \right]^{0.5}$$

**Design N-value** equals lesser of the following two conditions:

$$N_{AVG} - (N_{STD \text{ DEV}} \times 0.45)$$

Or

$$\text{Average of First Four N-Values} = \frac{(N@1' + N@2.5' + N@5' + N@7.5')}{4}$$

*Note: If less than 4 N-values are obtained because of criteria listed in Section 2 above, use average of N-values collected for second condition. Do not include the N-value at the deepest boring depth for above calculations if the boring is discontinued at or before the required boring depth because of criteria listed in Section 2 above. Use N-value of zero for weight of hammer or weight of rod. If N-value is greater than 50, reduce N-value to 50 for calculations.*

Submit completed boring logs collected in accordance with sub-section (1) Soil Test above along with pole loading diagrams to the contractor-selected pole fabricator to assist in the pole and foundation design.

If one of the following occurs, the Standard Foundations Chart shown on the plans may not be used and a non-standard foundation may be required. In such case, contact the Engineer.

- The Design N-value is less than 4.
- The drilled pier length, “L”, determined from the Standard Foundations Chart, is greater than the depth of the corresponding boring.

In the case where a standard foundation cannot be used, the Department will be responsible for the additional cost of the non-standard foundation.

Foundation designs are based on level ground around the traffic signal pole. If the slope around the edge of the drilled pier is steeper than 8:1 (H:V) or the proposed foundation will be less than 10 feet from the top of an embankment slope, the Contractor is responsible for providing slope information to the foundation designer and to the Engineer so it can be considered in the design.

The “Metal Pole Standard Foundation Selection Form” may be found at:

[https://connect.ncdot.gov/resources/Geological/Geotech%20Forms/2012\\_METAL%20POLES%20-%20Standard%20Foundation%20Selection.pdf](https://connect.ncdot.gov/resources/Geological/Geotech%20Forms/2012_METAL%20POLES%20-%20Standard%20Foundation%20Selection.pdf)

If assistance is needed, contact the Engineer.

#### **4. Non-Standard Foundation Design:**

Design non-standard foundations based upon site-specific soil test information collected in accordance with Section 2 (Soil Test) above. Design drilled piers for side resistance only in accordance with Section 4.6 of the *AASHTO Standard Specifications for Highway Bridges*. Use the computer software LPILE version 5.0 or later manufactured by Ensoft, Inc. to analyze drilled piers. Use the computer software gINT version 8.0 or later manufactured by Bentley Systems, Inc. with the current NCDOT gINT library and data template to produce SPT boring logs. Provide a drilled pier foundation for each pole with a length and diameter that result in a horizontal lateral movement of less than 1 inch at the top of the pier and a horizontal rotational movement of less than 1 inch at the edge of the pier. Contact the Engineer for pole loading diagrams for standard poles to be used for non-standard foundation designs. Submit any non-standard foundation designs including drawings, calculations, and soil boring logs to the Engineer for review and approval before construction. Foundations installed without prior approval may be rejected.

## **16.2. MATERIALS**

### **A. CCTV Metal Poles**

Furnish CCTV poles that are a minimum of 50 feet tall.

Fabricate CCTV metal pole from coil or plate steel to meet the requirements of ASTM A 595 Grade A tubes. For structural steel shapes, plates and bars use A572 Gr 50 min or ASTM A709 Gr 50 min.. Provide poles that are round in cross section or multisided tubular shapes and have a uniform linear taper of 0.14 in/ft. Construct shafts from one piece of single ply plate or coil so there are no circumferential weld splices. Galvanize in accordance with AASHTO M 111 and/or ASTM A 123 or an approved equivalent.

Ensure that allowable pole deflection does not exceed that allowed per *AASHTO Standard Specifications for Structural Supports for Highway Signs, Luminaries and Traffic Signals*, 6th Edition, 2013, including the latest interim specifications. Ensure that maximum deflection at the top of the pole does not exceed 2.5 percent of the pole height.

Use the submerged arc process or other NCDOT previously approved process suitable for poles to continuously weld pole shafts along their entire length. The longitudinal seam weld will be finished flush to the outside contour of the base metal. Ensure shafts have no circumferential welds except at the lower end joining the shaft to the pole base. In the event that a circumferential weld is necessary, prior approval is required from the Engineer and NCDOT Materials and Test Unit. Provide welding that conforms to Article 1072-20 of the Standard Specifications, except that no field welding on any part of the pole will be permitted unless approved by a qualified engineer.

Refer to Metal Pole Standard Drawing Sheets M2 through M5 for fabrication details. Fabricate anchor bases from plate steel meeting, as a minimum, the requirements of ASTM A 36M or cast steel meeting the requirements of ASTM A 27M Grade 485-250, AASHTO M270 Gr 36 or an approved equivalent. Conform to the applicable bolt pattern and orientation as shown on Metal Pole Standard Drawing Sheet M2.

Ensure all hardware is galvanized steel or stainless steel. The Contractor is responsible for ensuring that the designer/fabricator specifies connecting hardware and/or materials that do not create a dissimilar metal corrosive reaction.

Unless otherwise required by the design, ensure each anchor rod is 2" diameter and 60" length. Provide 10" minimum thread projection at the top of the rod, and 8" minimum at the bottom of the rod. Use anchor rod assembly and drilled pier foundation materials that meet the Foundations and Anchor Rod Assemblies for Metal Poles provision.

For each structural bolt and other steel hardware, hot dip galvanizing shall conform to the requirements of AASHTO M 232 (ASTM A 153). Ensure end caps for poles are constructed of cast aluminum conforming to Aluminum Alloy 356.0F.

Provide a circular anchor bolt lock plate that will be secured to the anchor bolts at the embedded end with 2 washers and 2 nuts. Provide a base plate template that matches the bolt circle diameter of the anchor bolt lock plate. Construct plates and templates from 1/4" minimum thick steel with a minimum width of 4". Galvanizing is not required.

Provide 4 heavy hex nuts and 4 flat washers for each anchor bolt. For nuts, use AASHTO M291 grade 2H, DH, or DH3 or equivalent material. For flat washers, use AASHTO M293 or equivalent material.

Provide a 2 inch hole equipped with an associated coupling and weatherhead approximately 5 feet below the top of the pole to accommodate passage of CCTV cables from inside the pole to the CCTV camera.

Provide a 2 inch hole equipped with an associated coupling and conduit fittings/bodies approximately 18 inches above the base of the pole accommodate passage of CCTV cables from the CCTV cabinet to the inside of the pole. Refer to Metal Pole Standard Drawing Sheet M3 for fabrication details.

Have poles permanently stamped above the base hand hole with the identification tag details as shown on Metal Pole Standard Drawing Sheet M2.

For each pole, provide a 1/2 inch minimum thread diameter, coarse thread stud and nut for grounding which will accommodate #4 AWG ground wire. Ensure that the lug is electrically bonded to the pole and is conveniently located inside the pole at the hand hole.

Provide a removable pole cap with stainless steel attachment screws for the top of each pole. Ensure that the cap is cast aluminum conforming to Aluminum Association Alloy 356.0F. Furnish cap attached to the pole with a sturdy chain or cable approved by the Engineer. Ensure that the chain or cable is long enough to permit the cap to hang clear of the pole-top opening when the cap is removed.

After fabrication, have steel poles and all parts used in the assembly hot-dip galvanized per section 1076. Design structural assemblies with weep holes large enough and properly located to drain molten zinc during galvanization process. Provide hot-dip galvanizing on structures that meets or exceeds ASTM Standard A-123. Provide galvanizing on hardware that meets or exceeds ASTM Standard A-153. Ensure that threaded material is brushed and retapped as necessary after galvanizing. Perform repair of damaged galvanizing that complies with the following:

- Repair of Galvanizing Article 1076-6

Standard Drawings for Metal Poles are available that supplement these project special provisions. These drawings are located on the Department's website:

<http://www.ncdot.gov/doh/preconstruct/traffic/ITSS/ws/mpoles/poles.html>

Comply with article 1098-1B "General Requirements" of the Standard Specifications for submittal requirements. Furnish shop drawings for approval. Provide the copies of detailed shop drawings for each type of structure as summarized below. Ensure that shop drawings include material specifications for each component and identify welds by type and size on the drawing details, not in table format. Do not release structures for fabrication until shop drawings have been approved by NCDOT. Provide an itemized bill of materials for all structural components and associated connecting hardware on the drawings.

All shop drawings must include project location description, CCTV inventory number(s), and a project number or work order number on the drawings.

Summary of information required for metal pole review submittal:

Item	Hardcopy Submittal	Electronic Submittal	Comments / Special Instructions
Sealed, Approved ITS Plan/Loading Diagram	1	1	All structure design information needs to reflect the latest approved ITS plans.
Custom Pole Shop Drawings	4 sets	1 set	Submit drawings on 11" x 17" format media. Show NCDOT project number and CCTV camera number in or above the title block.
Structure Calculations	1 set	1 set	Submit calculations on 8 ½" x 11" format media. Show NCDOT project number and CCTV camera number in the upper right corner of each page.
Custom Foundation Drawings	4 sets	1 set	Submit drawings on 11" x 17" format media. Show NCDOT project number and CCTV camera number in or above the title block.
Foundation Calculations	1	1	Submit calculations on 8 ½" x 11" format media. Show NCDOT project number and CCTV camera number in the upper right corner of each page.
Soil Boring Logs and Report	1	1	Report should include a location plan and a soil classification report including soil capacity, water level, hammer efficiency, soil bearing pressure, soil density, etc. for each pole.

**NOTE** – All shop drawings and custom foundation design drawings must be sealed by a professional Engineer licensed in the state of North Carolina. All geotechnical information must be sealed by either a Professional Engineer or geologist licensed in the state of North Carolina. Include a title block and revision block on the shop drawings and foundation designs showing the NCDOT inventory number.

Shop drawings and foundation drawings may be submitted together or separately for approval. However, shop drawings must be approved before foundations can be reviewed. Foundation designs will be returned without review if the associated shop drawing has not been approved. Incomplete submittals will be returned without review.

### 16.3. CONSTRUCTION METHODS

#### A. CCTV Metal Poles

Install anchor rod assemblies in accordance with the *Foundations and Anchor Rod Assemblies for Metal Poles* provision (SP09-R005) located on the Department's 2012 Standard Specifications and Provisions website:

<https://connect.ncdot.gov/resources/Specifications/Pages/Specifications-and-Special-Provisions.aspx>

Erect CCTV metal poles only after concrete has attained a minimum allowable compressive strength of 3,000 psi. For further construction methods, see construction methods for Metal Strain Pole.

Connect poles to grounding electrodes and bond them to the electrical service grounding electrodes.

For holes in the poles used to accommodate cables, install grommets before wiring pole or arm. Do not cut or split grommets.

Attach the hand hole covers to the pole by a sturdy chain or cable. Ensure the chain or cable is long enough to permit the cover to hang clear of the opening when the cover is removed, and is strong enough to prevent vandalism. Ensure the chain or cable will not interfere with service to the cables in the pole.

Attach cap to pole with a sturdy chain or cable. Ensure the chain or cable is long enough to permit the cap to hang clear of the opening when the cap is removed.

Perform repair of damaged galvanizing that complies with the Standard Specifications, Article 1076-6 "Repair of Galvanizing."

Install galvanized wire mesh around the perimeter of the base plate to cover the gap between the base plate and top of foundation for debris and pest control.

Install a 1/4" thick plate for concrete foundation tag to include: concrete grade, depth, diameter, and reinforcement sizes of the installed foundation.

Install CCTV metal poles, hardware, and fittings as shown on the manufacturer's installation drawings. Install poles so that when the pole is fully loaded it is within 2 degrees of vertical.

**B. Drilled Pier Foundations**

Construct drilled pier foundations in accordance with the *Foundations and Anchor Rod Assemblies for Metal Poles* provision.

**16.4. MEASUREMENT AND PAYMENT**

Actual number of CCTV Metal Poles furnished, installed and accepted.

Actual number of Soil Tests with SPT borings drilled furnished and accepted.

Actual volume of concrete poured in cubic yards of Drilled Pier Foundation furnished, installed and accepted.

No measurement will be made for CCTV Metal Pole designs and foundation designs, as these will be considered incidental to CCTV Metal Poles and Drilled Pier Foundations.

**Payment will be made under:**

CCTV Metal Pole .....	Each
Soil Test .....	Each
Drilled Pier Foundation.....	Cubic Yard



## 17. DYNAMIC MESSAGE SIGN (DMS)

### 17.1. DESCRIPTION

#### A. General Requirements

DMS units used on the State Highway System shall be preapproved on the current NCDOT ITS & Signals 2012 Qualified Products List (QPL) by the date of installation. DMS units not preapproved will not be allowed for use on the project. To ensure compatibility with the existing DMS Control Software deployed in the State, furnish NTCIP compliant DMS units that are fully compatible with Daktronics, Inc. Vanguard V4 software (also referred to hereinafter as the “Control Software”).

The QPL is available on the Department’s website. The QPL website is:

<https://connect.ncdot.gov/resources/safety/Pages/ITS-and-Signals-Qualified-Products.aspx>

Contact the Regional ITS Engineer at 336-315-7080 to confirm all DMS locations prior to beginning construction.

#### B. DMS Requirements

Furnish and install DMSs compliant with UL standards 48, 50, and 879.

Add and configure the new DMSs in the system using the Control Software and computer system. Furnish, install, test, integrate and make fully operational the new DMSs at locations shown in the Plans.

Furnish operating DMS systems consisting of, but not limited to, the following:

- Full Matrix, 27 pixel high and 90 pixels wide LED DMS with 18” border
- DMS mounting hardware
- DMS controllers, Uninterruptible Power Supplies (UPS), cabinets and accessories with interconnect and power cabling and conduit
- Branch circuit conductors and related equipment
- All other equipment and incidentals required for furnishing, installing, and testing the DMS system and system components

Use only UL listed and approved electronic and electrical components in the DMS system.

### 17.2. MATERIALS

#### A. Environmental Requirements

Construct the DMS and DMS controller cabinet so the equipment within is protected against moisture, dust, corrosion, and vandalism.

Design the DMS system to comply with the requirements of Section 2.1 (Environmental and Operating Standards) of NEMA TS 4-2005.

#### B. Full Matrix LED Dynamic Message Sign (DMS)

Construct the DMS to display at least three lines of text that, when installed, are clearly visible and legible to a person with 20/20 corrected vision from a distance of 900 feet in advance of the DMS at an eye height of 3.5 feet along the axis.

When displaying three lines, each line must display at least 15 equally spaced and equally sized alphanumeric individual characters. Each character must be at least 18 inches in height and composed from a luminous dot matrix. Provide an entire LED matrix that is a minimum of 27 pixels high and 90 pixels wide.

### **1. DMS Enclosure**

The DMS enclosure construction shall comply with the requirements of Section 3 (Sign Mechanical Construction) of NEMA TS 4-2005 as it applies to Walk-in enclosures. The following requirements complement TS 4-2005:

- Construct the DMS with a metal walk-in enclosure excluding the face. Provide an aluminum walking platform inside the enclosure that is at least 28 inches wide. Ensure the width of the walking platform is free of obstructions to a height of 7 feet. Construct the enclosure of welded aluminum type 6061-T6, 5052 H38, 5052-H34, or of an Engineer approved alternate at least 1/8-inch thick. Perform all welding of aluminum and aluminum alloys in accordance with the latest edition of AWS D1.2, Structural Welding Code - Aluminum. Continuously weld the seams using Gas Metal Arc Welding (GMAW).
- Provide all exterior and interior DMS enclosure surfaces with natural, mill-finish aluminum. Remove all grind marks and discoloration from the surfaces.
- Provide corrosion resistant nuts, bolts, washers, and other mounting and bonding parts and components used on the exterior of the DMS enclosure and ensure they are sealed against water intrusion.
- Provide one key lockable, hinged, gasket-sealed inspection door for service and maintenance along each side of the enclosure. Install one appropriately sized fire extinguisher within 12 inches of each maintenance door. Equip the DMS enclosure with internal fluorescent lighting controlled by timers installed close to each inspection door. Make certain no light emitted from the fluorescent tubes or any other light source inside the enclosure not comprising the display is leaked to the outside of the enclosure. Equip the door with a door-hold-open device. Install GFCI duplex utility receptacles every 6 feet along the width of the DMS in convenient locations for powered service tools.
- Do not place a manufacturer name, logo, or other information on the front face of the DMS or shield visible to the motorist.
- Provide power supply monitoring circuitry to detect power failure in the DMS and to automatically report this fault to the Control Software. This requirement shall be in addition to reporting power failure at the controller cabinet.
- Do not paint the stainless steel bolts on the Z-bar assembly used for mounting the enclosure.

### **2. DMS Interior Environment Control**

Design the local field controller to monitor and control the interior DMS environment. Design environmental control to maintain the internal DMS temperature within +/- 10o F of the outdoor ambient temperature. Provide the DMS environmental control system with four primary subsystems as follows:

1. Internal Temperature Sensors – Provide the DMS with two internally mounted temperature sensors which are equipped with external thermocouples and which the Field Controller continuously monitors. Design the Field Controller to use this temperature information to determine when to activate and deactivate the environmental control systems described herein. Locate sensors on opposite ends of the upper 1/3 of the LED display matrix with their external thermocouples attached to and making contact with an LED pixel circuit board. Design the thermocouple and LED board to be easily detachable, in the event that one of the units requires removal and replacement. Provide sensors capable of measuring temperatures from  $-40^{\circ}$  F to  $+185^{\circ}$  F. Design the Field Controller to automatically shut down the LED display whenever one or both sensors indicates that LED board temperature has exceeded  $+140^{\circ}$  F, and to automatically restart the LED display whenever the suspect temperature falls below  $+130^{\circ}$  F. Design both shutdown and re-start temperature thresholds to be user-programmable. Design the field controller to report sensor temperatures and DMS shutdown/re-start events to the DMS Control Software.
2. Housing Cooling System – Provide the DMS housing with a cooling system that circulates outside air into the DMS housing whenever the LED board temperature exceeds a user-programmable threshold. Provide this system with enough ventilation fans to exchange the internal DMS housing air volume at a minimum rate of 2 times per minute. Provide steel ball-bearing type fans. Mount fans in a line across the upper rear wall of the DMS housing to direct air out of the cabinet. Provide one filtered air intake port for each exhaust fan. Locate intake ports in a line across the lower rear wall of the DMS housing. Provide intake ports with a removable filter that will remove airborne particles measuring 500 microns in diameter and larger. Provide a filter that is of a size and style that is commercially readily available. Program the field controller to activate the DMS housing cooling system whenever the LED board temperature exceeds  $+90^{\circ}$  F and to turn the cooling system off whenever LED board temperature falls below  $+85^{\circ}$  F. On the DMS housing rear exterior wall, cover all air intake and exhaust ports on their top, front, and sides by an aluminum shroud fabricated from 0.090-inch aluminum sheeting. Taper the shrouds at the top. Securely fasten shrouds to the DMS housing, and provide gaskets at the interface to prevent water from entering the DMS. Design all air filters and fans to be removable from inside the DMS housing. Provide the DMS housing cooling system with an adjustable timer that will turn fans off after the set time has expired. Provide a timer that is adjustable to at least 4 hours, and locate it just inside the DMS housing door, within easy reach of a maintenance technician standing outside the DMS doorway.
3. LED Display Cooling System – Provide the DMS with an LED display cooling system which directs air across the LED display modules whenever LED board temperature exceeds a user-programmable threshold. Direct fan-forced air vertically across the backside of the entire LED display matrix using multiple ball-bearing fans. Program the field controller to activate the LED cooling fan system whenever LED board temperature exceeds  $+90^{\circ}$  F and to deactivate the system whenever LED board temperature falls to  $+85^{\circ}$  F. Locate cooling fans so as not to hinder removal of LED display modules and driver boards.

4. Front Face Panel Defog / Defrost System – Provide the DMS with a defog / defrost system which circulates warm, fan-forced air across the inside of the polycarbonate front face whenever LED board temperature falls below a user-programmable threshold. Provide multiple steel ball-bearing fans that provide uniform airflow across the face panel. Program the field controller to activate the defog / defrost system whenever LED board temperature falls below +40° F and to deactivate the defog/defrost system whenever LED board temperature exceeds +106° F. Mount a 100-watt pencil-style heating element in front of each defog / defrost fan to warm the air directed across the DMS face. Design heating elements to be on only when the defog / defrost fans are on.

Install additional fans and / or heaters as needed to maintain the temperature inside the DMS enclosure within the operating temperature range of the equipment within the DMS enclosure as recommended by the equipment manufacturer(s).

### **3. Front Panel**

Protect the DMS face with contiguous, weather-tight, removable panels. These panels must be a polycarbonate material that is ultraviolet protected, have an antireflection coating, and are a minimum of 1/8- inch thick.

Furnish polycarbonate panels with the following characteristics:

- Tensile Strength, Ultimate: 10,000 PSI
- Tensile Strength, Yield: 9,300 PSI
- Tensile Strain at Break: 125%
- Tensile Modulus: 330,000 PSI
- Flexural Modulus: 330,000 PSI
- Impact Strength, Izod (1/8", notched): 17 ft-lbs/inch of notch
- Rockwell Hardness: M75, R118
- Heat Deflection Temperature Under Load: 264 PSI at 270F and 66 PSI at 288F
- Coefficient of Thermal Expansion:  $3.9 \times 10^{-5}$  in/in/F
- Specific Heat: 0.30 BTU/lb/F
- Initial Light Transmittance: 85% minimum
- Change in Light Transmittance, 3 years exposure in a Southern latitude: 3%
- Change in Yellowness Index, 3 years exposure in a Southern latitude: less than 5%

For substitutes, submit one 12" x 12" sample of the proposed material together with a description of the material attributes to the Engineer for review and approval. Install a .09" aluminum mask on the front of the panel (facing the motorists) that contains a circular opening for each LED pixel. Prime and coat the front side of the aluminum mask, which faces the viewing motorists, with automotive-grade flat black acrylic enamel paint or an approved equivalent. Guarantee all painted surfaces provide a minimum outdoor service life of 20 years.

Design the panels so they will not warp nor reduce the legibility of the characters. Differential expansion of the DMS housing and the front panel must not cause damage to any DMS component or allow openings for moisture or dust. Glare from sunlight, roadway lighting, commercial lighting, or vehicle headlights must not reduce the legibility or visibility of the DMS. Install the panels so that a maintenance person can easily remove or open them for cleaning.

#### **4. Display Modules**

Manufacture each display module with a standard number of pixels, not to exceed an array of 9 x 5, which can be easily removed. Assemble the modules onto the DMS assemblies contiguously to form a continuous matrix to display the required number of lines, characters, and character height.

Design display modules that are interchangeable and replaceable without using special tools. Provide plug-in type power and communication cables to connect to a display module.

Construct each display module as a rectangular array of 5 horizontal pixels by 7 to 9 vertical pixels. Provide the module with an equal vertical and horizontal pitch between pixels, and columns that are perpendicular to the rows (i.e., no slant). Design each module to display:

- All upper and lower case letters.
- All punctuation marks.
- All numerals 0 to 9.
- Special user-created characters.

Display upper-case letters and numerals over the complete height of the module. Optimize the LED grouping and mounting angle within a pixel for maximum readability.

**Furnish two (2) spare display modules per each DMS installed for emergency restoration.**

#### **5. Discrete LEDs**

Provide discrete LEDs with a nominal viewing cone of **30 degrees** with a half-power angle of 15 degrees measured from the longitudinal axis of the LED. Make certain, the viewing cone tolerances are as specified in the LED manufacturer's product specifications and do not exceed +/- 3 degrees half-power viewing angle of 30 degrees.

Provide LEDs that are untinted, non-diffused, high output solid state lamps utilizing indium gallium aluminum phosphide (InGaAlP) technology. No substitutions will be allowed. Provide T1 3/4, 0.2 inch size LEDs that emit a true amber color at a wavelength of  $590 \pm 5$  nm.

Provide LEDs with a MTBF (Mean Time Before Failure) of at least 100,000 hours of permanent use at an operating point of 140° F or below at a specific forward current of 20mA. Discrete LED failure is defined as the point at which the LED's luminous intensity has degraded to 50% or less of its original level.

Obtain the LEDs used in the display from a single LED manufacturer that have a single part number. Obtain them from batches sorted for luminous output, where the highest luminosity LED is not more than fifty percent more luminous than the lowest luminosity LED when the LEDs are driven at the same forward current. Do not use more than two successive and overlapping batches in the LED display. Document the procedure to be used to comply with this requirement as part of the material submittal.

Individually mount the LEDs on circuit boards that are at least 1/16" thick FR-4 fiberglass, flat black printed circuit board in a manner that promotes cooling. Protect all exposed metal on both sides of the LED pixel board (except the power connector) from water and humidity exposure by a thorough application of acrylic conformal coating. Design the boards so bench level repairs to individual pixels, including discrete LED replacement and conformal coating repair is possible.

Operate the LED display at a low internal DC voltage not to exceed 24 Volts.

Design the LED display operating range to be  $-20^{\circ}$  F to  $+140^{\circ}$  F at 95% relative humidity, non-condensing.

Supply the LED manufacturer's technical specification sheet with the material submittals.

## **6. LED Power Supplies**

Power the LED Display by means of multiple regulated switching DC power supplies that operate from 120 volts AC input power and have an output of 48 volts DC or less. Wire the supplies in a redundant parallel configuration that uses multiple power supplies per display. Provide the supplies with current sharing capability that allows equal amounts of current to their portion of the LED display. Provide power supplies rated such that if one supply fails the remaining supplies will be able to operate their portion of the display under full load conditions (i.e. all pixels on at maximum brightness) and at a temperature of  $140^{\circ}$  F.

Provide power supplies to operate within a minimum input voltage range of  $+90$  to  $+135$  volts AC and within a temperature range of  $-22^{\circ}$  F to  $140^{\circ}$  F. Power supply output at  $140^{\circ}$  F must not deteriorate to less than 65% of its specified output at  $70^{\circ}$  F. Provide power supplies that are overload protected by means of circuit breakers, that have an efficiency rating of at least 75%, a power factor rating of at least .95, and are UL listed. Provide all power supplies from the same manufacturer and with the same model number. Design the power driver circuitry to minimize power consumption.

Design the field controller to monitor the operational status (normal or failed) of each individual power supply and be able to display this information on the Client Computer screen.

## **7. LED Pixels**

A pixel is defined as the smallest programmable portion of a display module that consists of a cluster of closely spaced discrete LEDs. Design each pixel to be a maximum of 2 inches in diameter.

Construct the pixels with two strings of LEDs. It is the manufacturer's responsibility to determine the number of LEDs in each string to produce the candela requirement as stated herein.

Ensure each pixel produces a luminous intensity of 40 Cd when driven with an LED drive current of 20 mA per string.

Power the LEDs in each pixel in strings. Use a redundant design so that the failure of an LED in one string does not affect the operation of any other string within the pixel. Provide the sign controller with the ability to detect the failure of any LED string and identify which LED string has failed. Submit a complete schematic of the LED power and driver circuits with the material submittals.

## 8. Character Display

Design display modules to be easily removable without the use of tools. Position cooling fans so they do not prevent removal of an LED pixel board or driver board.

Use continuous current to drive the LEDs at the maximum brightness level. Design the light levels to be adjustable for each DMS / controller so the Engineer may set levels to match the luminance requirements at each installation site.

Design the controller to automatically detect failed LED strings or drivers and initiate a report of the event to the Control Software. Design the controller to be able to read the internal temperature of the DMS enclosure and the ambient temperature outside the DMS enclosure and report these to the Control Software.

## 9. Display Capabilities

Design the DMS with at least the following message displays:

- Static display
- Flashing display with Dynamic flash rates
- At least two alternating Static and / or Flashing sequences (multi-page messages)

## 10. DMS Mini Controller

Furnish and install a mini controller inside the DMS that is interconnected with the main controller using a fiber optic cable, CAT-5 cable, or an approved alternate. The mini controller will enable a technician to perform all functions available from the main controller. Provide the mini controller with an LCD/keypad interface. Size the LCD display screen to allow preview of an entire one-page message on one screen. Provide a 4 X 4 keypad.

Alternatively, install an EIA/TIA-232E port inside the DMS enclosure to enable a maintenance technician to communicate with the DMS main controller and obtain access to and perform all functions of the main controller using a laptop computer.

## C. DMS Enclosure Structure Mounting

Mount the DMS enclosure and interconnect system securely to the supporting structures. Design the DMS enclosure supports and structure to allow full access to the DMS enclosure inspection door.

Furnish and install U-bolt connections of hanger beams to overhead assembly truss chords with a double nut at each end of the U-bolt. Bring the double nuts tight against each other by the use of two wrenches.

Submit plans for the DMS enclosure, structure, mounting description and calculations to the Engineer for approval. Have such calculations and drawings approved by a Professional Engineer registered in the state of North Carolina, and bear his signature, seal, and date of acceptance.

Provide removable lifting eyes or the equivalent on the DMS enclosure rated for its total weight to facilitate handling and mounting the DMS enclosure.

Design the DMS structure to conform to the applicable requirements of the *Standard Specifications for Structural Supports for Highway Signs, Luminaires*, and the section titled "DMS Assemblies" of these Project Special Provisions.

**D. DMS / DMS Controller Interconnect**

Furnish and install all necessary cabling, conduit, and terminal blocks to connect the DMS and the DMS controller. Use approved manufacturer's specifications and the Plans for cable and conduit types and sizes. Use fiber optic cable to interconnect sign and controller. Install fiber optic interconnect centers in the sign enclosure and cabinet to securely install and terminate the fiber optic cable. Submit material submittal cut sheets for the interconnect center.

**E. DMS Controller and DMS Cabinet**

Furnish and install one DMS controller with accessories per DMS in a new equipment cabinet. Mount the controller cabinet on the DMS support structure. Install cabinet so that the height from the ground to the middle of the cabinet is four feet. Ensure a minimum of three-foot level working surface under each cabinet that provides maintenance technicians with a safe working environment.

Provide the DMS controller as a software-oriented microprocessor and with resident software stored in non-volatile memory. The Control Software, controller and communications must comply with the NTCIP Standards identified in these Project Special Provisions. Provide sufficient non-volatile memory to allow storage of at least 500 multi-page messages and a test pattern program.

Furnish the controller cabinet with, but not limited to, the following:

- Power supply and distribution assemblies
- Power line filtering hybrid surge protectors
- Radio Interference Suppressor
- Communications surge protection devices
- Industrial-Grade UPS system and local disconnect
- Microprocessor-based controller
- Display driver and control system (unless integral to the DMS)
- Industrial-grade telephone line surge and lightning protector
- Serial interface port for local laptop computer
- Local user interface
- Interior lighting and duplex receptacle
- Adjustable shelves as required for components
- Temperature control system
- All interconnect harnesses, connectors, and terminal blocks
- All necessary installation and mounting hardware

Furnish the DMS controller and associated equipment completely housed in a NEMA 3R cabinet made from 5052-H32 sheet aluminum at least 1/8" thick. Use natural aluminum cabinets. Perform all welding of aluminum and aluminum alloys in accordance with the latest edition of AWS D1.2, Structural Welding Code - Aluminum. Continuously weld the seams using Gas Metal Arc Welding (GMAW).



Slant the cabinet roof away from the front of the cabinet to prevent water from collecting on it.

Do not place a manufacturer name, logo, or other information on the faces of the controller cabinet visible to the motorist.

Provide cabinets capable of housing the components and sized to fit space requirement. Design the cabinet layout for ease of maintenance and operation, with all components easily accessible. Submit a cabinet layout plan for approval by the Engineer.

Locate louvered vents with filters in the cabinet to direct airflow over the controller and auxiliary equipment, and in a manner that prevents rain from entering the cabinet. Fit the inside of the cabinet, directly behind the vents, with a replaceable, standard-size, commercially available air filter of sufficient size to cover the entire vented area.

Provide a torsionally rigid door with a continuous stainless steel hinge on the side that permits complete access to the cabinet interior. Provide a gasket as a permanent and weather resistant seal at the cabinet door and at the edges of the fan / exhaust openings. Use a non-absorbent gasket material that will maintain its resiliency after long-term exposure to the outdoor environment. Construct the doors so that they fit firmly and evenly against the gasket material when closed. Provide the cabinet door with louvered vents and air filters near the bottom as described in the paragraph above.

The cabinet shall contain a full-height standard EIA 19-inch rack. The rack shall be secured within the cabinet by mounts at the top and bottom.

The rack shall contain a minimum of one (1) pullout drawer. The drawer shall be suitable for storing manuals and small tools, such as screwdrivers. The drawer shall be able to latch in the out position to function as a laptop/utility shelf.

Provide a convenient location on the inside of the door to store the cabinet wiring diagrams and other related cabinet drawings. Provide a Corbin #2 main door lock made of non-ferrous or stainless steel material. Key all locks on the project alike, and provide 10 keys to the Engineer. In addition, design the handle to permit pad-locking.

Provide the interior of the cabinet with ample space for housing the controller and all associated equipment and wiring; use no more than 75% of the useable space in the cabinet. Provide ample space in the bottom of the cabinet for the entrance and exit of all power, communications, and grounding conductors and conduit.

Arrange the equipment so as to permit easy installation of the cabling through the conduit so that they will not interfere with the operation, inspection, or maintenance of the unit. Provide adjustable metal shelves, brackets, or other support for the controller unit and auxiliary equipment. Leave a 3 inch minimum clearance from the bottom of the cabinet to all equipment, terminals, and bus bars.

Provide power supply monitoring circuitry to detect power failure and to automatically report the occurrence to the Control Software.

Install two 15-watt fluorescent light strips with shields, one in the top of the cabinet and the other under the bottom shelf. Design both lights to automatically turn on when the cabinet door is opened and turn off when the door closes.

Mount and wire a 120V ( $\pm 10\%$ ) GFCI duplex receptacle of the 3-wire grounding type in the cabinet in a location that presents no electrical hazard when used by service personnel for the operation of power tools and work lights.

No cabinet resident equipment may utilize the GFCI receptacle. Furnish one spare non-GFCI receptacle for future equipment.

Mount a bug-proof and weatherproof thermostatically controlled fan and safety shield in the top of the cabinet. Size the fan to provide at least for two air exchanges per minute. Fuse the fan at 125% of the capacity of the motor. The magnetic field of the fan motor must not affect the performance of the control equipment. Use a fan thermostat that is manually adjustable to turn on between 80°F and 160°F with a differential of not more than 10°F between automatic turn-on and turn-off. Mount it in an easily accessible location, but not within 6 inches of the fan.

Install additional fans and/or heaters as needed to maintain the temperature inside the cabinet within the operating temperature range of the equipment within the cabinet as recommended by equipment manufacturer(s).

### **1. Wiring**

The requirements stated herein apply wherever electrical wiring is needed for any DMS system assemblies and subassemblies such as controller cabinet, DMS enclosure, electrical panel boards and etc.

Neatly arrange and secure the wiring inside the cabinet. Where cable wires are clamped to the walls of the control cabinet, provide clamps made of nylon, metal, plastic with rubber or neoprene protectors, or similar. Lace and jacket all harnesses, or tie them with nylon tie wraps spaced at 6 inches maximum to prevent separation of the individual conductors.

Individually and uniquely label all conductors. Ensure all conductor labels are clearly visible without moving the conductor. Connect all terminal conductors to the terminal strip in right angles. Remove excess conductor before termination of the conductor. Mold the conductor in such a fashion as to retain its relative position to the terminal strip if removed from the strip. Do not run a conductor across a work surface with the exception of connecting to that work surface. No conductor bundles can be supported by fasteners that support work surfaces. Install all connectors, devices and conductors in accordance to manufacturer's guidelines. Comply with the latest NEC guideline in effect during installation. No conductor or conductor bundle may hang loose or create a snag hazard. Protect all conductors from damage. Ensure all solder joints are completed using industry accepted practices and will not fail due to vibration or movement. Protect lamps and control boards from damage.

No splicing will be allowed for feeder conductors and communication cables from the equipment cabinet to the DMS enclosure.

Insulate all conductors and live terminals so they are not hazardous to maintenance personnel.

Route and bundle all wiring containing line voltage AC and / or shield it from all low voltage control circuits. Install safety covers to prevent accidental contact with all live AC terminals located inside the cabinet.

Use industry standard, keyed-type connectors with a retaining feature for connections to the controller.

Label all equipment and equipment controls clearly.

Supply each cabinet with one complete set of wiring diagrams that identify the color-coding or wire tagging used in all connections. Furnish a water-resistant packet adequate for storing wiring diagrams, operating instructions, and maintenance manuals with each cabinet.

## 2. Power Supply and Circuit Protection

Design the DMS and controller for use on a system with a line voltage of  $120V \pm 10\%$  at a frequency of  $60 \text{ Hz} \pm 3 \text{ Hz}$ . Under normal operation, do not allow the voltage drop between no load and full load of the DMS and its controller to exceed 3% of the nominal voltage.

Blackout, brownout, line noise, chronic over-voltage, sag, spike, surge, and transient effects are considered typical AC voltage defects. Protect the DMS system equipment so that these defects do not damage the DMS equipment or interrupt their operation. Equip all cabinets with devices to protect the equipment in the cabinet from damage due to lightning and external circuit power and current surges.

## 3. Circuit Breakers

Protect the DMS controller, accessories, and cabinet utilities with thermal magnetic circuit breakers. Provide the controller cabinet with a main circuit breaker sized according to the NEC. Use appropriately sized branch circuit breakers to protect the controller and accessories and for servicing DMS equipment and cabinet utilities.

## 4. Surge Suppressor

Install and clearly label filtering hybrid power line surge protectors on the load side of the branch circuit breakers in a manner that permits easy servicing. Ground and electrically bond the surge protector to the cabinet within 2 inches.

Provide power line surge protector that meets the following requirements:

Peak surge current occurrences	20 minimum
Peak surge current for an 8 x 20 microsecond waveshape	50,000 amperes
Energy Absorption	> 500 Joules
Clamp voltage	240 volts
Response time	<1 nanosecond
Minimum current for filtered output	15 amperes for 120VAC*
Temperature range	-40°F to +158°F

\*Capable of handling the continuous current to the equipment

## 5. Radio Interference Suppressor

Provide each controller cabinet with sufficient electrical and electronic noise suppression to enable all equipment in it to function properly. Provide one or more radio interference suppressors (RIS) connected between the stages of the power line surge suppressor that minimize interference generated in the cabinet in both the broadcast and the aircraft frequencies. Each RIS must provide a minimum attenuation of 50 decibels over a frequency range of 200 KHz to 75 MHz. Clearly label the suppressor(s) and size them at least at the rated current of the main circuit breaker but not less than 50 amperes.

Provide RIS that are hermetically sealed in a substantial metal case which is filled with a suitable insulating compound and have nickel-plated 10/24 brass stud terminals of sufficient external length to provide space to connect #8 AWG wires. Mount them so that the studs cannot be turned in the case. Properly insulate ungrounded terminals from each other, and maintain a surface linkage distance of not less than ¼” between any exposed current conductor and any other metallic parts. The terminals must have an insulation factor of 100-200 MΩ, dependent on external circuit conditions. Use RIS designed for 120 VAC ± 10%, 60Hz, and which meet the standards of UL and the Radio Manufacturers Association.

### 6. Communications Surge Protector

Equip the cabinet with properly labeled hybrid data line surge protectors that meet the following general requirements:

Surge current occurrences at 2000 ampere, 8 x 20 microsecond waveform	> 80
Surge current occurrences at 400 ampere, 10x700 microsecond waveform	> 80
Peak surge current for 8 x 20 microsecond waveform	10,000 A (2500 A/line)
Peak surge current for 10x700 microsecond waveform	500 A/line
Response time	< 1 nanosecond
Series resistance	< 15 Ω
Average capacitance	1500 pF
Temperature range	-10°F to 150°F
Clamp Voltage	As required to match equipment in application

### 7. Lightning Arrester

Protect the system with an UL-approved lightning arrester installed at the main service disconnect that meets the following requirements:

Type of design	Silicon Oxide Varistor
Voltage	120/240 Single phase, 3 wires
Maximum current	100,000 amps
Maximum energy	3000 joules per pole
Maximum number of surges	Unlimited
Response time one milliamp test	5 nanoseconds
Response time to clamp 10,000 amps	10 nanoseconds
Response time to clamp 50,000 amps	25 nanoseconds
Leak current at double the rated voltage	None

Ground Wire	Separate
-------------	----------

### 8. Uninterruptible Power Supply (UPS)

Provide the cabinet with an industrial grade power conditioning UPS unit to supply continuous power to operate the equipment connected to it if the primary power fails. The UPS must detect a power failure and provide backup power within 20 milliseconds. Transition to the UPS source from primary power must not cause loss of data or damage to the equipment being supplied with backup power. Provide an UPS with at least three outlets for supplying conditioned AC voltage to the DMS controller. Provide a unit to meet the following requirements:

- Input Voltage Range: 120VAC +12%, -25%
- Power Rating: 1000 VA, 700 Watts
- Input Frequency: 45 to 65 Hz
- Input Current: 7.2A
- Output Voltage: 120VAC +/- 3%
- Output Frequency: 50/60 +/-1 Hz
- Output Current: 8.3A
- Output Crest Factor Ratio: @50% Load Up to 4.8:1  
@75% Load Up to 3.2:1  
@100% Load Up to 2.4:1
- Output THD: 3% Max. (Linear)  
5% Max. (Non-Linear)
- Output Overload: 110% for 10 min; 200% for 0.05 sec.
- Output Dynamic Response: +/- 4% for 100% Step Load Change  
0.5 ms Recovery Time.
- Output Efficiency @ 100% Load: 90% (Normal Mode)
- Operating Temperature: -40 °F to +165 °F
- Humidity: 0% to 95% Non-condensing
- Remote Monitoring Interface: RS-232
- Protection: Input/Output Short Circuit  
Input/Output Overload  
Excessive Battery Discharge
- Specifications: UL1778, FCC Class A, IEEE 587

Provide the UPS unit capable of supplying 30 minutes of continuous backup power to the equipment connected to it when the equipment is operating at full load.

## 9. Controller Communications Interface

Provide the controller with the following interface ports:

- An EIA/TIA-232E port for remote communication using NTCIP
- An 10/100 Ethernet port for remote communication using NTCIP
- An EIA/TIA-232E port for onsite access using a laptop
- An EIA/TIA-232E auxiliary port for communication with a field device such as a UPS
- Fiber Optic ports for communication with the sign
- RJ45 ports for communication with the sign using CAT-5 cable
- RJ45 ports for communication with mini-controller located inside the sign enclosure

## 10. Controller Local User Interface

Provide the controller with a Local User Interface (LUI) for at least the following functions:

- On / Off Switch: controls power to the controller.
- Control Mode Switch: for setting the controller operation mode to either remote or local mode.
- LCD Display and Keypad: Allow user to navigate through the controller menu for configuration (display, communications parameter, etc.) running diagnostics, viewing peripherals status, message creation, message preview, message activation, and etc. Furnish a LCD display with a minimum size of 240x64 dots with LED back light.

## 11. Controller Address

Assign each DMS controller a unique address. Preface all commands from the Control Software with a particular DMS controller address. The DMS controller compares its address with the address transmitted; if the addresses match, then the controller processes the accompanying data.

## 12. Controller Functions

Design the DMS controller to continuously control and monitor the DMS independent of the Control Software. Design the controller to display a message on the sign sent by the Control Software, a message stored in the sign controller memory, or a message created on-site by an operator using the controller keypad.

Provide the DMS controller with a watchdog timer to detect controller failures and to reset the microprocessor, and with a battery backed-up clock to maintain an accurate time and date reference. Set the clock through an external command from the Control Software or the Local User Interface.

## 13. DMS Controller Memory

Furnish each DMS controller with non-volatile memory. Use the non-volatile memory to store and reprogram at least one test pattern sequence and 500 messages containing a minimum of two pages of 45 characters per page. The Control Software can upload messages into and download messages from each controller's non-volatile memory remotely.

Messages uploaded and stored in the controller's non-volatile memory may be erased and edited using the Control Software and the controller. New messages may be uploaded to and stored in the controller's non-volatile memory using the Control Software and the controller.

#### **F. Photo-Electric Sensors**

Install three photoelectric sensors with ½ inch minimum diameter photosensitive lens inside the DMS enclosure. Use sensors that will operate normally despite continual exposure to direct sunlight. Place the sensors so they are accessible and field adjustable. Point one sensor north or bottom of the sign. Place the other two, one on the back wall and one on the front wall of the sign enclosure. Alternate designs maybe accepted, provided the sensor assemblies are accessible and serviceable from inside the sign enclosure.

Provide controls so that the Engineer can field adjust the following:

- The light level emitted by the pixels elements in each Light Level Mode.
- The ambient light level at which each Light Level Mode is activated.

#### **G. Equipment List**

Provide a general description of all equipment and all information necessary to describe the basic use or function of the major system components. Include a general "block diagram" presentation. Include tabular charts listing auxiliary equipment, if any is required. Include the nomenclature, physical and electrical characteristics, and functions of the auxiliary equipment unless such information is contained in an associated manual; in this case include a reference to the location of the information. Include an itemized list of equipment costs.

Include a table itemizing the estimated average and maximum power consumption for each major piece of equipment.

#### **H. Physical Description**

Provide a detailed physical description of size, weight, center of gravity, special mounting requirements, electrical connections, and all other pertinent information necessary for proper installation and operation of the equipment.

#### **I. Parts List**

Provide a parts list that contains all information needed to describe the characteristics of the individual parts, as required for identification. Include a list of all equipment within a group and a list of all assemblies, sub-assemblies, and replacement parts of all units. Arrange this data in a table, in alpha-numerical order of the schematic reference symbols, which gives the associated description, manufacturer's name, and part number, as well as alternate manufacturers and part numbers. Provide a table of contents or other appropriate grouping to identify major components, assemblies, etc.

#### **J. Character Set Submittal**

Submit an engineering drawing of the DMS character set including 26 upper case and lower case letters, 10 numerals, an asterisk (\*), a dash, a plus sign (+), a designated lane diamond, a slash, an ampersand, and arrows at 0, 45, 90, 135, 180, 225, 270, and 315 degrees.

#### **K. Wiring Diagrams**

Provide a wiring diagram for each DMS and each controller cabinet, as well as interconnection wiring diagrams for the system as a whole.

Provide complete and detailed schematic diagrams to component level for all DMS assemblies and subassemblies such as driver boards, control boards, DMS controller, power supplies, and etc. Ensure that each schematic enables an electronics technician to successfully identify any component on a board or assemblies and trace its incoming and outgoing signals.

#### **L. Routine of Operation**

Describe the operational routine, from necessary preparations for placing the equipment into operation to securing the equipment after operation. Show appropriate illustrations with the sequence of operations presented in tabular form wherever applicable. Include in this section a total list of the test instruments, aids and tools required to perform necessary measurements and measurement techniques for each component, as well as set-up, test, and calibration procedures.

#### **M. Maintenance Procedures**

Specify the recommended preventative maintenance procedures and checks at pre-operation, monthly, quarterly, semi-annual, annual, and "as required" periods to assure equipment operates reliably. List specifications (including tolerances) for all electrical, mechanical, and other applicable measurements and / or adjustments.

#### **N. Repair Procedures**

Include in this section all data and step-by-step procedures necessary to isolate and repair failures or malfunctions, assuming the maintenance technicians are capable of analytical reasoning using the information provided in the section titled "Wiring Diagrams and Theory of Operation."

Describe accuracy, limits, and tolerances for all electrical, physical, or other applicable measurements. Include instructions for disassemblies, overhaul, and re-assemblies, with shop specifications and performance requirements.

Give detailed instructions only where failure to follow special procedures would result in damage to equipment, improper operation, danger to operating or maintenance personnel, etc. Include such instructions and specifications only for maintenance that specialized technicians and engineers in a modern electromechanical shop would perform. Describe special test set-up, component fabrication, and the use of special tools, jigs, and test equipment.

#### **O. Field Trial**

At the request of the Engineer, supply a three character demonstration module with characters of the size and type specified for the project, an appropriate control device and power supply to allow character display within 30 working days of the request. Perform a field trial on this module at a time and location selected by the Engineer.

This trial will allow the Engineer or his selected representatives to test the readability of the DMS at the maximum distance required for specified character size. Test the module with the sun directly above the DMS, and near the horizon in front of and behind the DMS (washout and back-lit conditions).

### **17.3. CONSTRUCTION METHODS**

#### **A. Description**

This article establishes practices and procedures and gives minimum standards and requirements for the installation of Dynamic Message Sign systems, auxiliary equipment and the construction of related structures.



Provide electrical equipment described in this specification that conforms to the standards of NEMA, UL, or Electronic Industries Association (EIA), wherever applicable. Provide connections between controllers and electric utilities that conform to NEC standards. Express wire sizes according to the American Wire Gauge (AWG).

Provide stainless steel screws, nuts, and locking washers in all external locations. Do not use self-tapping screws unless specifically approved by the Engineer. Use parts made of corrosion-resistant materials, such as plastic, stainless steel, brass, or aluminum. Use construction materials that resist fungus growth and moisture deterioration. Separate dissimilar metals by an inert dielectric material.

### **B. Layout**

The Engineer will establish the actual location of each Dynamic Message Sign assemblies. It is the Contractor's responsibility to ensure proper elevation, offset, and orientation of all DMS assemblies. The location of service poles as well as conduit lengths shown in the Plans, are approximate based on available project data. Make actual field measurements to place conduit and equipment at the required location.

### **C. Construction Submittal**

When the work is complete, submit "as built" plans, inventory sheets, and any other data required by the Engineer to show the details of actual construction and installation and any modifications made during installation.

The "as built" plans will show: the DMS, controller, and service pole locations; DMS enclosure and controller cabinet wiring layouts; and wire and conduit routing. Show all underground conduits and cables dimensioned from fixed objects.

Include detailed drawings that identify the routing of all conductors in the system by cable type, color code, and function. Clearly label all equipment in the DMS system, controller cabinet, and DMS enclosure.

### **D. Conduit**

Install the conduit system in accordance with section 1715 of Standard Specification and NEC requirements for an approved watertight raceway.

Make bends in the conduit so as not to damage it or change its internal diameter. Install watertight and continuous conduit with as few couplings as standard lengths permit.

Clean conduit before, during, and after installation. Install conduit in such a manner that temperature changes will not cause elongation or contraction that might damage the system.

Attach the conduit system to and install along the structural components of the DMS structure assemblies with beam clamps or stainless steel strapping. Install strapping according to the strapping manufacturer's recommendations. Do not use welding or drilling to fasten conduit to structural components. Space the fasteners at no more than 4 feet for conduit 1.5 inches and larger or 6 feet for conduit smaller than 1.25 inches. Place fasteners no more than 3 feet from the center of bends, fittings, boxes, switches, and devices.

Locate underground conduit as shown in the Plans in a manner consistent with these Project Special Provisions.

Do not exceed the appropriate fill ratio on all cable installed in conduit as specified in the NEC.

**E. Wiring Methods**

Do not pull permanent wire through a conduit system until the system is complete and has been cleaned.

Color-code all conductors per the NEC. Use approved marking tape, paint, sleeves or continuous colored conductors for No.8 AWG and larger. Do not mark a white conductor in a cable assemblies any other color.

Bury underground circuits at the depth shown in the Plans and surround it with at least 3 inches of sand or earth back-fill free of rocks and debris. Compact backfill in 6 inch layers. Do not splice underground circuits unless specifically noted in the Plans.

**F. Equipment and Cabinet Mounting**

Mount equipment securely at the locations shown in the Plans, in conformance with the dimensions shown. Install fasteners as recommended by the manufacturer and space them evenly. Use all mounting holes and attachment points for attaching DMS enclosures and controller cabinets to the structures.

Drill holes for expansion anchors of the size recommended by the manufacturer of the anchors and thoroughly clean them of all debris.

Provide one key-operated, pin tumbler, dead bolt padlock, with brass or bronze shackle and case, conforming to Military Specification MIL-P-17802E (Grade I, Class 2, Size 2, Style A) for each electrical panel and switch on the project. Key all padlocks alike, and provide 10 keys to the Engineer.

Provide cabinets with all mounting plates, anchor bolts, and any other necessary mounting hardware in accordance with these Project Special Provisions and the Plans.

Seal all unused conduit installed in cabinets at both ends to prevent water and dirt from entering the conduit and cabinet with approved sealing material.

Install a ground bushing attached inside the cabinet on all metal conduits entering the cabinet. Connect these ground bushings to the cabinet ground bus.

**G. Work Site Clean-Up**

Clean the site of all debris, excess excavation, waste packing material, wire, etc. Clean and clear the work site at the end of each workday. Do not throw waste material in storm drains or sewers.

**17.4. MEASUREMENT AND PAYMENT**

*DMS* will be measured and paid as the actual number of *DMS* furnished, installed, and accepted. Each *DMS* consists of a LED Dynamic Message Sign, spare LED modules, communications equipment, strapping hardware, controller, UPS, controller cabinet, conduit, fittings, couplings, sweeps, conduit bodies, wire, flexible conduit, feeder conductors and communications cable between the controller cabinet and the *DMS* enclosure, connectors, circuit protection equipment, photo-electric sensors, tools, materials, all related testing, cost of labor, cost of transportation, incidentals, and all other equipment necessary to furnish and install the *DMS* system.

U-2579C

**ITS-59**

Forsyth County

Payment will be made under:

<b>Pay Item</b>	<b>Pay Unit</b>
DMS .....	Each

## 18. NTCIP REQUIREMENTS

This section defines the detailed NTCIP requirements for the DMS units covered by these Project Special Provisions and Plans.

### 18.1. REFERENCES

This specification references several standards through their NTCIP designated names. The following list provides the full reference to the current version of each of these standards.

Implement the most recent version of the standard including any and all Approved or Recommended Amendments to these standards for each NTCIP Component covered by these project specifications.

**Table 1: NTCIP Standards**

<b>Abbreviated Number</b>	<b>Full Number</b>	<b>Title</b>
NTCIP 1101	<b>NTCIP 1101:1997</b>	<i>Simple Transportation Management Framework</i>
NTCIP 1201	<b>NTCIP 1201:1997</b>	<i>Global Object Definitions</i>
NTCIP 1203	<b>NTCIP 1203:1997</b>	<i>Object Definitions for Dynamic Message Signs</i>
NTCIP 2001	<b>NTCIP 2001:1997</b>	<i>Class B Profile</i>
NTCIP 2101	<b>NTCIP 2101</b>	<i>SP-PMPP/232 Subnet Profile for PMPP over RS-232</i>
NTCIP 2102	<b>NTCIP 2102</b>	<i>SP-PMPP/FSK Subnet Profile for PMPP over FSK Modem</i>
NTCIP 2103	<b>NTCIP 2103</b>	<i>SP-PPP/232 Subnetwork Profile for PPP over RS232 (Dial Up)</i>
NTCIP 2104	<b>NTCIP 2104</b>	<i>SP-Ethernet Subnet Profile for Ethernet</i>

<b>Abbreviated Number</b>	<b>Full Number</b>	<b>Title</b>
NTCIP 2201	<b>NTCIP 2201</b>	<i>TP-Null Transport Profile</i>
NTCIP 2202	<b>NTCIP 2202</b>	<i>TP-Internet Internet Transport Profile (TCP/IP and UDP/IP)</i>
NTCIP 2301	<b>NTCIP 2301</b>	AP-STMF AP for Simple Transportation Management Framework

### **A. General Requirements**

#### **Subnet Level**

Ensure each serial port on each NTCIP Component supports NTCIP 2103 over a dial-up connection with a contractor provided external modem with data rates of 28.8 kbps, 19.2 kbps, 14.4 kbps, 9600 bps, 4800 bps, 2400 bps, 1200 bps, 600 bps, and 300 bps. Enable the NTCIP Component to make outgoing and receive incoming calls as necessary and support the following modem command sets:

- Hayes AT - Command Set
- MNP5
- MNP10
- V.42bis

Ensure each serial port on each NTCIP Component supports NTCIP 2103 over a null-modem connection with data rates of 19.2 kbps, 14.4 kbps, 9600 bps, 4800 bps, 2400 bps, 1200 bps, 600 bps, and 300 bps.

Ensure each serial port on each NTCIP Component supports NTCIP 2101 with data rates of 9600 bps, 4800 bps, 2400 bps, 1200 bps, 600 bps, and 300 bps.

Ensure NTCIP components support NTCIP 2102 and NTCIP 2104.

NTCIP Components may support additional Subnet Profiles at the manufacturer's option. At any one time, make certain only one Subnet Profile is active on a given serial port of the NTCIP Component. Ensure the NTCIP Component can be configured to allow the field technician to activate the desired Subnet Profile and provide a visual indication of the currently selected Subnet Profile.

#### **Transport Level**

Ensure each NTCIP Component complies with NTCIP 2201 and 2202.

NTCIP Components may support additional Transport Profiles at the manufacturer's option. Ensure Response datagrams use the same Transport Profile used in the request. Ensure each NTCIP

Component supports the receipt of datagrams conforming to any of the identified Transport Profiles at any time.

### Application Level

Ensure each NTCIP Component complies with NTCIP 1101 and 2301 and meets the requirements for Conformance Level 1 (NOTE - See Amendment to standard).

Ensure each NTCIP Component supports SNMP traps. An NTCIP Component may support additional Application Profiles at the manufacturer's option. Ensure Responses use the same Application Profile used by the request. Ensure each NTCIP Component supports the receipt of Application data packets at any time allowed by the subject standards.

### Information Level

Guarantee each NTCIP Component provides Full, Standardized Object Range Support of all objects required by these Special Provisions unless otherwise indicated below. Make certain the maximum Response Time for any object or group of objects is 200 milliseconds.

Design the DMS to support all mandatory objects of all mandatory Conformance Groups as defined in NTCIP 1201 and NTCIP 1203. Table 2 indicates the modified object requirements for these mandatory objects.

**Table 2: Modified Object Ranges for Mandatory Objects**

Object	Reference	Project Requirement
ModuleTableEntry	NTCIP 1201 Clause 2.2.3	Contains at least one row with moduleType equal to 3 (software). The moduleMake specifies the name of the manufacturer, the moduleModel specifies the manufacturer's name of the component and the modelVersion indicates the model version number of the component.
MaxGroupAddresses	NTCIP 1201 Clause 2.7.1	At least 1
CommunityNamesMax	NTCIP 1201 Clause 2.8.2	At least 3
DmsNumPermanentMsg	NTCIP 1203 Clause 2.6.1.1.1.1	At least 1*
DmsMaxChangeableMsg	NTCIP 1203 Clause 2.6.1.1.1.3	At least 21
DmsFreeChangeableMemory	NTCIP 1203 Clause 2.6.1.1.1.4	At least 20 when no messages are stored.

Object	Reference	Project Requirement
DmsMessageMultiString	NTCIP 1203 Clause 2.6.1.1.1.8.3	The DMS supports any valid MULTI string containing any subset of those MULTI tags listed in Table 4
DmsControlMode	NTCIP 1203 Clause 2.7.1.1.1.1	Support at least the following modes:  Local  External central  CentralOverride

\* Ensure the Permanent Messages display the content shown in Table 3.

Ensure the sign blanks if a command to display a message contains an invalid Message CRC value for the desired message.

**Table 3: Content of Permanent Messages**

Perm. Msg. Num.	<u>Description</u>
1	Permanent Message #1 blanks the display (i.e., consist of and empty MULTI string). It has a run-time priority of one (1).

**Table 4: Required MULTI Tags**

Code	Feature
f1	field 1 - time (12hr)
f2	field 2 - time (24hr)
f8	field 8 – day of month
f9	field 9 – month
f10	field 10 - 2 digit year
f11	field 11 - 4 digit year
fl (and /fl)	flashing text on a line by line basis with flash rates controllable in 0.5 second increments.
fo	Font

Code	Feature
jl2	Justification – line – left
jl3	Justification – line – center
jl4	Justification – line – right
jl5	Justification – line – full
jp2	Justification – page – top
jp3	Justification – page – middle
jp4	Justification – page – bottom
Mv	moving text
Nl	new line
Np	new page, up to 2 instances in a message (i.e., up to 3 pages/frames in a message counting first page)
Pt	page times controllable in 0.5 second increments.

The NTCIP Component implements all mandatory and optional objects of the following optional conformance groups with FSORS.

### Test Heading

#### a. Time Management

As defined in NTCIP 1201

#### b. Timebase Event Schedule

As defined in NTCIP 1201. The following list indicates the modified object requirements for this conformance group.

**Table 5: Modified Object Ranges for the Timebase Event Schedule Conformance Group**

Object	Reference	Project Requirement
MaxTimeBaseScheduleEntries	NTCIP 1201 Clause 2.4.3.1	At least 28
maxDayPlans	NTCIP 1201 Clause 2.4.4.1	At least 14
maxDayPlanEvents	NTCIP 1201 Clause 2.4.4.2	At least 10

#### c. Report



As defined in NTCIP 1201. The following list indicates the modified object requirements for this conformance group.

**Table 6: Modified Object Ranges for the Report Conformance Group**

Object	Reference	Project Requirement
maxEventLogConfigs	NTCIP 1201 Clause 2.5.1	At least 50
eventConfigurationMode	NTCIP 1201 Clause 2.4.3.1	The NTCIP Component supports the following Event Configuration Modes: onChange greaterThanValue smallerThanValue
MaxEventLogSize	NTCIP 1201 Clause 2.5.3	At least 200
MaxEventClasses	NTCIP 1201 Clause 2.5.5	At least 16

**d. PMPP**

**e. Font Configuration**

As defined in NTCIP 1203. The following list indicates the modified object requirements for this conformance group.

**Table 7: Modified Object Ranges for the Font Configuration Conformance Group**

Object	Reference	Project Requirement
NumFonts	NTCIP 1203 Clause 2.4.1.1.1.1	At least 4*
MaxFontCharacters	NTCIP 1203 Clause 2.4.1.1.1.3	At least 127**

\*Upon delivery, the first font is a standard 18” font. The second font is a double-stroke 18” font. The third font is a 28” font. The fourth font is empty.

\*\*Upon delivery, the first three font sets are configured in accordance with the ASCII character set for the following characters:

- “A” thru “Z”- All upper case letters.
- “0” thru “9”- All decimal digits.
- Space (i.e., ASCII code 0x20).
- Punctuation marks shown in brackets [ . , ! ? - ‘ ’ “ ” / ( ) ]
- Special characters shown in brackets [# & \* + < >]

**f. DMS Configuration**

As defined in NTCIP 1203.

**g. MULTI Configuration**

As defined in NTCIP 1203. The following list indicates the modified object requirements for this conformance group.

**Table 8: Modified Object Ranges for the MULTI Configuration Conformance Group**

Object	Reference	Project Requirement
DefaultBackgroundColor	NTCIP 1203 Clause 2.5.1.1.1.1	The DMS supports the following background colors: black
DefaultForegroundColor	NTCIP 1203 Clause 2.5.1.1.1.2	The DMS supports the following foreground colors: amber
DefaultJustificationLine	NTCIP 1203 Clause 2.5.1.1.1.6	The DMS supports the following forms of line justification: left center right full
defaultJustificationPage	NTCIP 1203 Clause 2.5.1.1.1.7	The DMS supports the following forms of page justification: top middle bottom
defaultPageOnTime	NTCIP 1203 Clause 2.5.1.1.1.8	The DMS supports the full range of these objects with step sizes no larger than 0.5 seconds
defaultPageOffTime	NTCIP 1203 Clause 2.5.1.1.1.9	The DMS supports the full range of these objects with step sizes no larger than 0.5 seconds
defaultCharacterSet	NTCIP 1203 Clause 2.5.1.1.1.10	The DMS supports the following character sets: eightBit

**h. Default Message Control** as defined in NTCIP 1203

**i. Pixel Service Control** as defined in NTCIP 1203

- j. **MULTI Error Control** as defined in NTCIP 1203
- k. **Illumination/Brightness Control**

As defined in NTCIP 1203. The following list indicates the modified object requirements for this conformance group.

**Table 9: Modified Object Ranges for the Illumination/Brightness Control Conformance Group**

Object	Reference	Project Requirement
dmsIllumControl	NTCIP 1203 Clause 2.8.1.1.1.1	The DMS supports the following illumination control modes: photocell timer manual
dmsIllumNumBrightLevels	NTCIP 1203 Clause 2.8.1.1.1.4	At least 16

- l. **Auxiliary I/O**
- m. **Scheduling**

As defined in NTCIP 1203. The following list indicates the modified object requirements for this conformance group.

**Table 10: Modified Object Ranges for the Scheduling Conformance Group**

Object	Reference	Project Requirement
NumActionTableEntries	NTCIP 1203 Clause 2.9.1.1.1.1	At least 21

- n. **Sign Status** as defined in NTCIP 1203
- o. **Status Error** as defined in NTCIP 1203
- p. **Pixel Error Status** as defined in NTCIP 1203
- q. **Fan Error Status** as defined in NTCIP 1203
- r. **Power Status** as defined in NTCIP 1203
- s. **Temperature Status** as defined in NTCIP 1203

Install necessary hardware for the support of items q, r, and s above.

**Table 11: Some Optional Object Requirements**

<b>Object</b>	<b>Reference</b>	<b>Project Requirement</b>
DefaultFlashOn	NTCIP 1203 Clause 2.5.1.1.1.3	The DMS supports the full range of these objects with step sizes no larger than 0.5 seconds
DefaultFlashOff	NTCIP 1203 Clause 2.5.1.1.1.4	The DMS supports the full range of these objects with step sizes no larger than 0.5 seconds
DmsMultiOtherErrorDescription	NTCIP 1203 Clause 2.7.1.1.1.20	If the vendor implements any vendor-specific MULTI tags, the DMS shall provide meaningful error messages within this object whenever one of these tags generates an error.

**Documentation**

Supply software with full documentation, including a CD-ROM containing ASCII versions of the following MIB files in Abstract Syntax Notation 1 (ASN.1) format:

- The relevant version of each official standard MIB Module referenced by the device functionality.
- If the device does not support the full range of any given object within a Standard MIB Module, a manufacturer specific version of the official Standard MIB Module with the supported range indicated in ASN.1 format in the SYNTAX and/or DESCRIPTION fields of the associated OBJECT TYPE macro. Name this file identical to the standard MIB Module, except that it will have the extension ".man".
- A MIB Module in ASN.1 format containing any and all manufacturer-specific objects supported by the device with accurate and meaningful DESCRIPTION fields and supported ranges indicated in the SYNTAX field of the OBJECT-TYPE macros.
- A MIB containing any other objects supported by the device.

Allow the use of any and all of this documentation by any party authorized by the Department for systems integration purposes at any time initially or in the future, regardless of what parties are involved in the systems integration effort.

**B. NTCIP Acceptance Testing**

Test the NTCIP requirements outlined above by a third party testing firm. Submit to the Engineer for approval a portfolio of the selected firm. Include the name, address, and a history of the selected firm in performing NTCIP testing along with references. Also provide a contact person's name and phone number. Submit detailed NTCIP testing plans and procedures, including a list of hardware

and software, to the Engineer for review and approval 10 days in advance of a scheduled testing date. Develop test documents based on the NTCIP requirements of these Project Special Provisions. The acceptance test will use the NTCIP Exerciser, and/or other authorized testing tools and will follow the guidelines established in the ENTERPRISE Test Procedures. Conduct the test in North Carolina on the installed system in the presence of the Engineer. Document and certify the results of the test by the firm conducting the test and submit the Engineer for review and approval. In case of failures, remedy the problem and have the firm retest in North Carolina. Continue process until all failures are resolved. The Department reserves the right to enhance these tests as deemed appropriate to ensure device compliance.

**18.2. MEASUREMENT AND PAYMENT**

There will be no direct payment for the work covered by this section.

Payment for this work will be covered in the applicable sections of these Project Special Provisions at the contract unit price for "DMS" and will be full compensation for all work listed above.

**19. DMS ASSEMBLIES****19.1. DESCRIPTION**

This section includes all design, fabrication, furnishing, and erection of the DMS assemblies, platforms, walkways, ladders for access to the DMS inspection doors, and attachment of the DMS enclosures to the structures in accordance with the requirements of these Project Special Provisions and the Plans. Fabricate the supporting DMS assemblies from tubular steel. Furnish pedestal type DMS assemblies as shown in the Plans. Cantilevered and monotube (horizontal truss) DMS structures will not be allowed.

Provide pedestal DMS structures with a minimum of 25 feet clearance from the high point of the road to the bottom of the DMS enclosure.

Design the new DMS assemblies (including footings), DMS mounting assemblies, maintenance platforms, and access ladders and submit shop drawings for approval. A Professional Engineer that is registered in the state of North Carolina will prepare such computations and drawings. These must bear his signature, seal, and date of acceptance.

The provisions of Section 900 of the Standard Specifications apply to all work covered by this section.

It is the Contractor's responsibility to provide DMS S-dimension elevation drawings for the DMS locations to the Engineer for approval.

**19.2. MATERIAL**

Refer to Division 10.

Use materials that meet the following requirements of the Standard Specifications:

Structural Steel	Section 1072
Overhead Sign Structures	Section 1096
Signing Materials	Section 1092
Organic-Zinc Repair Paint	Article 1080-9
Reinforcing Steel	Sub-article 1070
Direct Tension Indicators	Sections 440 and 1072

**19.3. CONSTRUCTION METHODS****A. General**

Fabricate the new DMS assemblies, maintenance platforms, attachment hardware, and access ladders in accordance with the details shown in the approved shop drawings and the requirements of these Project Special Provisions.

No welding, cutting, or drilling in any manner will be permitted in the field, unless approved by the Engineer.

Drill bolt holes and slots to finished size. Holes may also be punched to finished size, provided the diameter of the punched holes are at least twice the thickness of the metal being punched. Flame cutting of bolt holes and slots is not permitted.

Erect DMS in accordance with the requirements indicated on the Plans and in these Project Special Provisions. Field drill two holes per connection in the Z bars for attaching the DMS to the structure. Use two bolts at each connection. Provide two (2) U-bolts at each U-bolt connection such as 1) each truss chord to sign hanger, or 2) each truss chord to platform support. Provide two (2) U-bolts at each U-bolts connection where ends of truss chords are supported. Minimum diameter of all U-bolts is to be ½ inch.

Use two coats of a zinc-rich paint to touch up minor scars on all galvanized materials. See Standard Specifications for Roads and Structures Section 1076-6.

For high strength bolted connections, provide direct tension indicator washer.

## **B. Shop Drawing**

Submit to the Engineer for approval a complete design for the DMS assemblies (including footings) maintenance platforms, access ladders, DMS assembly hardware, brackets for supporting the DMS and maintenance platforms. Base the design on the line drawings and correct wind speed in accordance with the latest edition of AASHTO *Standard Specifications for Structural Supports for Highway Signs, Luminaries and Traffic Signals, 6<sup>th</sup> Edition, 2013 and 2015 Interim Revisions*.

The manufacturer of the DMS assembly must ensure that design of the assembly is compatible with the DMSs for mounting and attachment.

Submit electronic (.pdf) copies of completely detailed shop drawings and one copy of the design computations for the DMS assembly to the Engineer for approval prior to fabrication. Show in the shop drawings complete design and fabrication details including foundations, provisions for attaching the DMS, maintenance platform and access ladders to supporting structures, applicable material specifications, and any other information necessary for procuring and replacing any part of the complete DMS assembly.

Allow a minimum of 15 working days for shop drawing approval after the Engineer receives them. If revised drawings are necessary, allow an additional 15 working days for review and approval of final shop drawings.

Approval of shop drawings by the Engineer will not relieve the Design-Build Team of their responsibility for the correctness of drawings, or for the fit of all shop and field connections and anchors.

## **C. Design and Fabrication**

For additional design and fabrication requirements, reference the Overhead Sign Supports Project Special Provision found elsewhere in these Project Special Provisions.

### **1. Dynamic Message Sign Assemblies**

Fabricate the supporting structures using tubular members of either aluminum or steel, using only one type of material throughout the project.

Horizontal components of the supporting structures for overhead DMS shall be of a truss design to support the DMS. Truss centerline shall coincide with the centerline of the DMS design area shown on the structure line drawing developed by the Design-Build Team. Provide permanent camber in addition to dead load camber in accordance with the AASHTO *Standard Specifications for Structural Supports for Highway Signs, Luminaires, and Traffic Signals, 6th Edition, 2013 and*

2015 Interim Revisions. Indicate on the shop drawings the amount of camber provided and the method employed in the fabrication of the support to obtain the camber.

For all U-bolt connections of hanger beams to overhead assembly truss chords, provide U-bolts with a flat washer, a lock washer and double nuts at each end of the U-bolts. All double nuts that are on any U-bolt shall be the same thickness and weight. When assembled, the double nuts shall be brought tight against each other by the use of two wrenches.

Fabricate the attachment assembly for mounting DMS in a manner that will ensure easy removal the DMS.

## **2. DMS Maintenance Platform (Walkway)**

Provide a maintenance platform, a minimum of three feet wide with open skid resistant surface and safety railing on the DMS assemblies for access to the DMS inspection door. Provide platforms with fixed safety railings along both sides from the beginning of the platform to the inspection door.

Ensure the design, fabrication and installation of the access platforms on new DMS structures complies with the following:

1. The top of the platform grading surface is vertically aligned with the bottom of the DMS door. Ensure the platform extends from the DMS enclosure to the access ladder.
2. The DMS door will open 90-degrees from its closed position without any obstruction from the platform or safety handrails.
3. The platform is rigidly and directly connected to the walkway brackets and there is no uneven surface between sections.
4. Install a 4" x 4" safety angle parallel to and along both sides of the platform and extend it the entire length of the platform. Design the safety angle to withstand loading equivalent to the platform.
5. Ensure the platform design allows full access to the DMS enclosure inspection door with no interference or obstructions.

## **3. DMS Access Ladder**

Provide a fixed ladder, of the same material as the DMS structures, leading to and ending at the access platform. Equip the ladder with a security cover (ladder guard) and lock to prohibit access by unauthorized persons. Furnish locks to operate with a Corbin #2 key and furnish two keys per lock. Design the rungs on 12-inch center to center typical spacing. The first ladder rung shall be no more than 18 inches above the landing pad. Attach the security cover approximately 6 feet above the concrete landing. Design the ladder and security cover as a permanent part of the DMS assembly and include complete design details in the DMS assembly shop drawings. Fabricate the ladder and cover to meet all OSHA requirements and applicable state and local codes, including but not limited to providing a ladder cage.

Furnish and install a level concrete pad a minimum of 4 inches deep, 24 inches wide, and 36 inches long to serve as a landing pad for accessing the ladder. Design the landing pad to be directly below the bottom rung. Access to the ladder shall not be obstructed by the DMS foundation. Provide pre-formed or cast-in place concrete pads.



**19.4. MEASUREMENT AND PAYMENT**

*DMS Pedestal Structure* will be measured and paid as the actual number of dynamic message sign assemblies furnished, installed, and accepted. Payment includes all design, fabrication, construction, transportation, and attachment of the complete dynamic message sign assemblies, supporting structure, hardware, access platform, direct tension indicators, preparing and furnishing shop drawings, additional documentation, incidentals, and all other equipment and features necessary to furnish the system described above.

*DMS Access Ladder* will be measured and paid as the actual number of DMS access ladders furnished, installed and accepted. Payment includes design, fabrication, transportation, and attachment to the DMS assembly and the concrete landing pad as described above.

Payment will be made under:

<b>Pay Item</b>	<b>Pay Unit</b>
DMS Pedestal Structure .....	Each
DMS Access Ladder .....	Each

## 20. FOUNDATIONS AND ANCHOR ROD ASSEMBLIES FOR METAL POLES

### 20.1. DESCRIPTION

Foundations for metal poles include foundations for signals, cameras, overhead and dynamic message signs (DMS) and high mount and low level light standards supported by metal poles or upright trusses. Foundations consist of footings with pedestals and drilled piers with or without grade beams or wings. Anchor rod assemblies consist of anchor rods (also called anchor bolts) with nuts and washers on the exposed ends of rods and nuts and a plate or washers on the other ends of rods embedded in the foundation.

Construct concrete foundations with the required resistances and dimensions and install anchor rod assemblies in accordance with the contract and accepted submittals. Construct drilled piers consisting of cast-in-place reinforced concrete cylindrical sections in excavated holes. Provide temporary casings or polymer slurry as needed to stabilize drilled pier excavations. Use a prequalified Drilled Pier Contractor to construct drilled piers for metal poles. Define "excavation" and "hole" as a drilled pier excavation and "pier" as a drilled pier.

This provision does not apply to materials and anchor rod assemblies for standard foundations for low level light standards. See Section 1405 of the *2012 Standard Specifications* and Standard Drawing No. 1405.01 of the *2012 Roadway Standard Drawings* for materials and anchor rod assemblies for standard foundations. For construction of standard foundations for low level light standards, standard foundations are considered footings in this provision.

This provision does not apply to foundations for signal pedestals; see Section 1743 of the *2012 Standard Specifications* and Standard Drawing No. 1743.01 of the *2012 Roadway Standard Drawings*.

### 20.2. MATERIAL

Refer to the *2012 Standard Specifications*.

<b>Item</b>	<b>Section</b>
Conduit	1091-3
Grout, Nonshrink	1003
Polymer Slurry	411-2(B)
Portland Cement Concrete	1000
Reinforcing Steel	1070
Rollers and Chairs	411-2(C)
Temporary Casings	411-2(A)

Provide Type 3 material certifications in accordance with Article 106-3 of the *2012 Standard Specifications* for conduit, rollers, chairs and anchor rod assemblies. Store steel materials on blocking at least 12" above the ground and protect it at all times from damage; and when placing in the work make sure it is free from dirt, dust, loose mill scale, loose rust, paint, oil or other foreign materials. Load, transport, unload and store foundation and anchor rod assembly materials so materials are kept clean and free of damage. Damaged or deformed materials will be rejected.

Use conduit type in accordance with the contract. Use Class A concrete for footings and pedestals, Class Drilled Pier concrete for drilled piers and Class AA concrete for grade beams and wings including portions of drilled piers above bottom of wings elevations. Corrugated temporary casings may be accepted at the discretion of the Engineer. A list of approved polymer slurry products is available from:

[www.ncdot.org/doh/preconstruct/highway/geotech/leftmenu/Polymer.html](http://www.ncdot.org/doh/preconstruct/highway/geotech/leftmenu/Polymer.html)

Provide anchor rod assemblies in accordance with the contract consisting of the following:

- A. Straight anchor rods,
- B. Heavy hex top and leveling nuts and flat washers on exposed ends of rods, and
- C. Nuts and either flat plates or washers on the other ends of anchor rods embedded in foundations.

Do not use lock washers. Use steel anchor rods, nuts and washers that meet ASTM F1554 for Grade 55 rods and Grade A nuts. Use steel plates and washers embedded in concrete with a nominal thickness of at least 1/4". Galvanize anchor rods and exposed nuts and washers in accordance with Article 1076-4 of the *2012 Standard Specifications*. It is not necessary to galvanize nuts, plates and washers embedded in concrete.

### **20.3. CONSTRUCTION METHODS**

Install the required size and number of conduits in foundations in accordance with the plans and accepted submittals. Construct top of piers, footings, pedestals, grade beams and wings flat, level and within 1" of elevations shown in the plans or approved by the Engineer. Provide an Ordinary Surface finish in accordance with Subarticle 825-6(B) of the *2012 Standard Specifications* for portions of foundations exposed above finished grade. Do not remove anchor bolt templates or pedestal or grade beam forms or erect metal poles or upright trusses onto foundations until concrete attains a compressive strength of at least 3,000 psi.

#### **A. Drilled Piers**

Before starting drilled pier construction, hold a predrill meeting to discuss the installation, monitoring and inspection of the drilled piers. Schedule this meeting after the Drilled Pier Contractor has mobilized to the site. The Resident or Division Traffic Engineer, Contractor and Drilled Pier Contractor Superintendent will attend this predrill meeting.

Do not excavate holes, install piles or allow equipment wheel loads or vibrations within 20 ft of completed piers until 16 hours after Drilled Pier concrete reaches initial set.

Check for correct drilled pier alignment and location before beginning drilling. Check plumbness of holes frequently during drilling.

Construct drilled piers with the minimum required diameters shown in the plans. Install piers with tip elevations no higher than shown in the plans or approved by the Engineer.

Excavate holes with equipment of the sizes required to construct drilled piers. Depending on the subsurface conditions encountered, drilling through rock and boulders may be required. Do not use blasting for drilled pier excavations.

Contain and dispose of drilling spoils and waste concrete as directed and in accordance with Section 802 of the *2012 Standard Specifications*. Drilling spoils consist of all materials and fluids removed from excavations.

If unstable, caving or sloughing materials are anticipated or encountered, stabilize holes with temporary casings and/or polymer slurry. Do not use telescoping temporary casings. If it becomes necessary to replace a temporary casing during drilling, backfill the excavation, insert a larger casing around the casing to be replaced or stabilize the excavation with polymer slurry before removing the temporary casing.

If temporary casings become stuck or the Contractor proposes leaving casings in place, temporary casings should be installed against undisturbed material. Unless otherwise approved, do not leave temporary casings in place for mast arm poles and cantilever signs. The Engineer will determine if casings may remain in place. If the Contractor proposes leaving temporary casings in place, do not begin drilling until a casing installation method is approved.

Use polymer slurry and additives to stabilize holes in accordance with the slurry manufacturer's recommendations. Provide mixing water and equipment suitable for polymer slurry. Maintain polymer slurry at all times so slurry meets Table 411-3 of the *2012 Standard Specifications* except for sand content.

Define a "sample set" as slurry samples collected from mid-height and within 2 ft of the bottom of holes. Take sample sets from excavations to test polymer slurry immediately after filling holes with slurry, at least every 4 hours thereafter and immediately before placing concrete. Do not place Drilled Pier concrete until both slurry samples from an excavation meet the required polymer slurry properties. If any slurry test results do not meet the requirements, the Engineer may suspend drilling until both samples from a sample set meet the required slurry properties.

Remove soft and loose material from bottom of holes using augers to the satisfaction of the Engineer. Assemble rebar cages and place cages and Drilled Pier concrete in accordance with Subarticle 411-4(E) of the *2012 Standard Specifications* except for the following:

- 1) Inspections for tip resistance and bottom cleanliness are not required,
- 2) Temporary casings may remain in place if approved, and
- 3) Concrete placement may be paused near the top of pier elevations for anchor rod assembly installation and conduit placement or
- 4) If applicable, concrete placement may be stopped at bottom of grade beam or wings elevations for grade beam or wing construction.

If wet placement of concrete is anticipated or encountered, do not place Drilled Pier concrete until a concrete placement procedure is approved. If applicable, temporary casings and fluids may be removed when concrete placement is paused or stopped in accordance with the exceptions above provided holes are stable. Remove contaminated concrete from exposed Drilled Pier concrete after removing casings and fluids. If holes are unstable, do not remove temporary casings until a procedure for placing anchor rod assemblies and conduit or constructing grade beams or wings is approved.

Use collars to extend drilled piers above finished grade. Remove collars after Drilled Pier concrete sets and round top edges of piers.

If drilled piers are questionable, pile integrity testing (PIT) and further investigation may be required in accordance with Article 411-5 of the *2012 Standard Specifications*. A drilled pier will be considered defective in accordance with Subarticle 411-5(D) of the *2012 Standard Specifications* and drilled pier acceptance is based in part on the criteria in Article 411-6 of the *2012 Standard Specifications* except for the top of pier tolerances in Subarticle 411-6(C) of the *2012 Standard Specifications*.

If a drilled pier is under further investigation, do not grout core holes, backfill around the pier or perform any work on the drilled pier until the Engineer accepts the pier. If the drilled pier is accepted, dewater and grout core holes and backfill around the pier with approved material to finished grade. If the Engineer determines a pier is unacceptable, remediation is required in accordance with Article 411-6 of the *2012 Standard Specifications*. No extension of completion date or time will be allowed for remediation of unacceptable drilled piers or post repair testing.

Permanently embed a plate in or mark top of piers with the pier diameter and depth, size and number of vertical reinforcing bars and the minimum compressive strength of the concrete mix at 28 days.

### **B. Footings, Pedestals, Grade Beams and Wings**

Excavate as necessary for footings, grade beams and wings in accordance with the plans, accepted submittals and Section 410 of the *2012 Standard Specifications*. If unstable, caving or sloughing materials are anticipated or encountered, shore foundation excavations as needed with an approved method. Notify the Engineer when foundation excavation is complete. Do not place concrete or reinforcing steel until excavation dimensions and foundation material are approved.

Construct cast-in-place reinforced concrete footings, pedestals, grade beams and wings with the dimensions shown in the plans and in accordance with Section 825 of the *2012 Standard Specifications*. Use forms to construct portions of pedestals and grade beams protruding above finished grade. Provide a chamfer with a 3/4" horizontal width for pedestal and grade beam edges exposed above finished grade. Backfill and fill in accordance with Article 410-8 of the *2012 Standard Specifications*. Proper compaction around footings and wings is critical for foundations to resist uplift and torsion forces. Place concrete against undisturbed soil and do not use forms for standard foundations for low level light standards.

### **C. Anchor Rod Assemblies**

Size anchor rods for design and the required projection above top of foundations. Determine required anchor rod projections from nut, washer and base plate thicknesses, the protrusion of 3 to 5 anchor rod threads above top nuts after tightening and the distance of one nut thickness between top of foundations and bottom of leveling nuts.

Protect anchor rod threads from damage during storage and installation of anchor rod assemblies. Before placing anchor rods in foundations, turn nuts onto and off rods past leveling nut locations. Turn nuts with the effort of one workman using an ordinary wrench without a cheater bar. Report any thread damage to the Engineer that requires extra effort to turn nuts.

Arrange anchor rods symmetrically about center of base plate locations as shown in the plans. Set anchor rod elevations based on required projections above top of foundations. Securely brace and hold rods in the correct position, orientation and alignment with a steel template. Do not weld to reinforcing steel, temporary casings or anchor rods.

Install top and leveling (bottom) nuts, washers and the base plate for each anchor rod assembly in accordance with the following procedure:

- 1) Turn leveling nuts onto anchor rods to a distance of one nut thickness between the top of foundation and bottom of leveling nuts. Place washers over anchor rods on top of leveling nuts.
- 2) Determine if nuts are level using a flat rigid template on top of washers. If necessary, lower leveling nuts to level the template in all directions or if applicable, lower nuts to tilt the template so the metal pole or upright truss will lean as shown in the plans. If leveling nuts and washers are not in full contact with the template, replace washers with galvanized beveled washers.
- 3) Verify the distance between the foundation and leveling nuts is no more than one nut thickness.
- 4) Place base plate with metal pole or upright truss over anchor rods on top of washers. High mount luminaires may be attached before erecting metal poles but do not attach cables, mast arms or trusses to metal poles or upright trusses at this time.
- 5) Place washers over anchor rods on top of base plate. Lubricate top nut bearing surfaces and exposed anchor rod threads above washers with beeswax, paraffin or other approved lubricant.
- 6) Turn top nuts onto anchor rods. If nuts are not in full contact with washers or washers are not in full contact with the base plate, replace washers with galvanized beveled washers.
- 7) Tighten top nuts to snug-tight with the full effort of one workman using a 12" wrench. Do not tighten any nut all at once. Turn top nuts in increments. Follow a star pattern cycling through each nut at least twice.
- 8) Repeat (7) for leveling nuts.
- 9) Replace washers above and below the base plate with galvanized beveled washers if the slope of any base plate face exceeds 1:20 (5%), any washer is not in firm contact with the base plate or any nut is not in firm contact with a washer. If any washers are replaced, repeat (7) and (8).
- 10) With top and leveling nuts snug-tight, mark each top nut on a corner at the intersection of 2 flats and a corresponding reference mark on the base plate. Mark top nuts and base plate with ink or paint that is not water-soluble. Use the turn-of-nut method for pretensioning. Do not pretension any nut all at once. Turn top nuts in increments for a total of one flat (1/6 revolution) for anchor rod diameters greater than 1 1/2" and 2 flats (1/3 revolution) for anchor rod diameters 1 1/2" or less. Follow a star pattern cycling through each top nut at least twice.
- 11) Ensure nuts, washers and base plate are in firm contact with each other for each anchor rod. Cables, mast arms and trusses may now be attached to metal poles and upright trusses.
- 12) Between 4 and 14 days after pretensioning top nuts, use a torque wrench calibrated within the last 12 months to check nuts in the presence of the Engineer. Completely erect

mast arm poles and cantilever signs and attach any hardware before checking top nuts for these structures. Check that top nuts meet the following torque requirements:

TORQUE REQUIREMENTS	
Anchor Rod Diameter, inch	Requirement, ft-lb
7/8	180
1	270
1 1/8	380
1 1/4	420
$\geq 1\ 1/2$	600

If necessary, retighten top nuts in the presence of the Engineer with a calibrated torque wrench to within  $\pm 10$  ft-lb of the required torque. Do not overtighten top nuts.

- (13) Do not grout under base plate.

#### **20.4. MEASUREMENT AND PAYMENT**

Foundations and anchor rod assemblies for metal poles and upright trusses will be measured and paid for elsewhere in the contract.

No payment will be made for temporary casings that remain in drilled pier excavations. No payment will be made for PIT. No payment will be made for further investigation of defective piers. Further investigation of piers that are not defective will be paid as extra work in accordance with Article 104-7 of the *2012 Standard Specifications*. No payment will be made for remediation of unacceptable drilled piers or post repair testing.

## 21. DYNAMIC MESSAGE SIGN STRUCTURE FOUNDATIONS

### 21.1. DESCRIPTION

Dynamic Message Sign (DMS) foundations include foundations for DMS supported by metal poles or upright trusses. DMS structure foundations consist of footings with pedestals or drilled piers with or without grade beams or wings, conduit and anchor rod assemblies. Construct sign foundations in accordance with the contract and accepted submittals.

### 21.2. MATERIAL

Use sign foundation materials that meet the *Foundations and Anchor Rod Assemblies for Metal Poles* provision.

#### A. Assumed Subsurface Conditions

Assume the following soil parameters and groundwater elevation for sign foundations unless these subsurface conditions are not applicable to sign locations:

- A. Unit weight ( $\gamma$ ) = 120 lb/cf,
- B. Friction angle ( $\phi$ ) = 30°,
- C. Cohesion ( $c$ ) = 0 lb/sf, and
- D. Groundwater 7 ft below finished grade.

A subsurface investigation is required if the Engineer determines these assumed subsurface conditions do not apply to a sign location and the sign cannot be moved. Subsurface conditions requiring a subsurface investigation include but are not limited to weathered or hard rock, boulders, very soft or loose soil, muck or shallow groundwater. No extension of completion date or time will be allowed for subsurface investigations.

#### B. Subsurface Investigations

Use a prequalified geotechnical consultant to perform one standard penetration test (SPT) boring in accordance with ASTM D1586 at each sign location requiring a subsurface investigation. Rough grade sign locations to within 2 ft of finished grade before beginning drilling. Drill borings to 2 drilled pier diameters below anticipated pier tip elevations or refusal, whichever is higher.

Use the computer software gINT version 8.0 or later manufactured by Bentley Systems, Inc. with the current NCDOT gINT library and data template to produce SPT boring logs. Provide boring logs sealed by a geologist or engineer licensed in the state of North Carolina.

#### C. Sign Foundation Designs

Design sign foundations for the wind zone and clearances shown in the plans and the slope of finished grade at each sign location. Use the assumed soil parameters and groundwater elevation above for sign foundation designs unless a subsurface investigation is required. For sign locations requiring a subsurface investigation, design sign foundations for the subsurface conditions at each sign location. Design footings, pedestals, drilled piers, grade beams and wings in accordance with the 6th Edition of the *AASHTO Standard Specifications for Structural Supports for Highway Signs, Luminaires and Traffic Signals*. In some instances, conflicts with drainage structures may dictate sign foundation types.



Design footings in accordance with Section 4.4 of the *AASHTO Standard Specifications for Highway Bridges*. Do not use an allowable bearing pressure of more than 3,000 lb/sf for footings.

Design drilled piers for side resistance only in accordance with Section 4.6 of the *AASHTO Standard Specifications for Highway Bridges* except reduce ultimate side resistance by 25% for uplift. Use the computer software LPILE version 5.0 or later manufactured by Ensoft, Inc. to analyze drilled piers. Provide drilled pier designs with a horizontal deflection of less than 1" at top of piers. For cantilever signs with single drilled pier foundations supporting metal poles, use wings to resist torsion forces. Provide drilled pier designs with a factor of safety of at least 2.0 for torsion.

For drilled pier sign foundations supporting upright trusses, use dual drilled piers connected with a grade beam having a moment of inertia approximately equal to that of either pier. The Broms' method is acceptable to analyze drilled piers with grade beams instead of LPILE. Use a safety factor of at least 3.5 for the Broms' design method in accordance with C13.6.1.1 of the *AASHTO Standard Specifications for Structural Supports for Highway Signs, Luminaires and Traffic Signals*.

Submit boring logs, if any, working drawings and design calculations for acceptance in accordance with Article 105-2 of the *2012 Standard Specifications*. Submit working drawings showing plan views, required foundation dimensions and elevations and typical sections with reinforcement, conduit and anchor rod assembly details. Include all boring logs, design calculations and LPILE output for sign foundation design submittals. Have sign foundations designed, detailed and sealed by an engineer licensed in the state of North Carolina.

**21.3. CONSTRUCTION METHODS**

Construct footings, pedestals, drilled piers, grade beams and wings and install anchor rod assemblies for sign foundations in accordance with the *Foundations and Anchor Rod Assemblies for Metal Poles* provision.

**21.4. MEASUREMENT AND PAYMENT**

*Overhead DMS Structure Footings* will be measured and paid in cubic yards. DMS structure footings will be measured as the cubic yards of foundation concrete for footings, pedestals, drilled piers, grade beams and wings shown on the accepted submittals. The contract unit price will be full compensation for providing labor, tools, equipment and foundation materials, stabilizing or shoring excavations and supplying concrete, reinforcing steel, conduit, anchor rod assemblies and any incidentals necessary to construct sign foundations. Subsurface investigations required by the Engineer will be paid as extra work in accordance with Article 104-7 of the *2012 Standard Specifications*.

Payment will be made under:

<b>Pay Item</b>	<b>Pay Unit</b>
Overhead DMS Structure Footings.....	Cubic Yards

## 22. LOCAL AREA NETWORK HARDWARE

### 22.1. DESCRIPTION

Furnish, install, and fully integrate new local area network (LAN) hardware as called for in the Plans.

Furnish and install hardened and managed field Ethernet edge switches (hereafter “edge switch”) for field devices at locations as shown in the Plans. Ensure that the edge switch provides Ethernet connectivity at transmission rates of 1000 megabits per second from each remote ITS device location as shown in the Plans to the existing managed core Ethernet switch at the TRTMC.

Furnish and install central digital video decoders for converting digital video to analog video at the TRTMC.

Furnish and install central media converters for converting digital communications to analog serial communications for integration with the existing DMS server at the TRTMC.

Furnish and install copper Ethernet cable for interconnecting various hardware in an Ethernet network located in the CCTV cabinets, the DMS cabinets, and the TRTMC.

Install and test Department-furnished cellular telephone modems and antennas to provide back-up communications to DMS cabinets.

### 22.2. MATERIAL

#### A. General

##### 1. Ethernet Standards

Ensure that the Ethernet Switches comply with all applicable IEEE networking standards for Ethernet communications, including but not limited to:

- IEEE 802.1D standard for media access control (MAC) bridges used with the Spanning Tree Protocol (STP),
- IEEE 802.1P standard for Quality of Service (QoS),
- IEEE 802.1Q standard for port-based virtual local area networks (VLANs),
- IEEE 802.1Q-2005 standard for MAC bridges used with the Multiple Spanning Tree Protocol,
- IEEE 802.1w standard for MAC bridges used with the Rapid Spanning Tree Protocol (RSTP),
- IEEE 802.1x standard for port based network access control, including RADIUS,
- IEEE 802.3 standard for local area network (LAN) and metropolitan area network (MAN) access and physical layer specifications, including auto negotiation of speed,
- IEEE 802.3u supplement standard regarding 100 Base TX/100 Base FX,
- IEEE 802.3x standard regarding flow control with full duplex operation,
- RFC 783 – TFTP,
- RFC 854 – Telnet Protocol Specification,

- RFC 1112 – IGMP v1,
- RFC 1541 – Dynamic Host Configuration Protocol for IPv4,
- RFC 2030 – SNMP,
- RFC 2068 – HTTP,
- RFC 2236 – IGMP v2,
- RFC 2865 – RADIUS,
- RFC 3414 – SNMPv3-USM, and
- RFC 3415 – SNMPv3-VACM

Ensure that the Ethernet switches have a minimum mean time between failures (MTBF) of 10 years, or 87,600 hours, as calculated using the Bellcore/Telcordia SR-332 standard for reliability prediction.

## **2. Functional Requirements**

Ensure that the Ethernet switches support all Layer 2 management features and certain Layer 3 features related to multicast data transmission. These features shall include, but not be limited to:

- An STP healing/convergence rate that meets or exceeds specifications published in the IEEE 802.1D standard,
- An RSTP healing/convergence rate that meets or exceeds specifications published in the IEEE 802.1w standard,
- An Ethernet switch that is a port-based VLAN and supports VLAN tagging that meets or exceeds specifications as published in the IEEE 802.1Q standard, and has a minimum 4-kilobit VLAN address table (254 simultaneous),
- A forwarding/filtering rate that is a minimum of 14,880 packets per second for 10 megabits per second and 148,800 packets per second for 100 megabits per second,
- A minimum 4-kilobit MAC address table,
- Support of Traffic Class Expediting and Dynamic Multicast Filtering,
- Support of, at a minimum, snooping of Version 2 of the Internet Group Management Protocol (IGMP),
- Support of remote and local setup and management via telnet or secure Web-based GUI and command line interfaces,
- Support of the Simple Network Management Protocol version 3 (SNMPv3). Verify that the Ethernet edge switch can be accessed using the resident EIA-232 management port, a telecommunication network, or the Trivial File Transfer Protocol (TFTP),
- Port security through controlling access by the users. Ensure that the Ethernet edge switch has the capability to generate an alarm and shut down ports when an unauthorized user accesses the network,
- Support of the TFTP and SNMP. Ensure that the Ethernet edge switch supports port mirroring for troubleshooting purposes when combined with a network analyzer.

### **3. Electrical Requirements**

Ensure that the Ethernet switches operate and power is supplied at 120 VAC. Ensure that the Ethernet switches have a minimum operating input of 110 VAC and a maximum operating input of 130 VAC. Ensure that if the switch requires operating voltages other than 120 VAC, supply the required voltage converter. Ensure that the maximum power consumption does not exceed 50 watts. Ensure that the Ethernet switches have diagnostic light emitting diodes (LEDs), including link, TX, RX, speed (for Category 5e ports only), and power LEDs.

#### **B. Ethernet Edge Switch**

##### **1. Mounting:**

Provide shelf mount edge switches. Optionally, if cabinet space dictates, provide a mounting kit to attach the edge switch to a vertical rack rail or a DIN rail in the cabinet. If the Contractor elects to use DIN rail mounting supply the DIN rail with the edge switch.

##### **2. Ports:**

Provide 10/100/1000 Mbps auto-negotiating ports (RJ-45) copper Ethernet ports for all edge switches. Provide auto-negotiation circuitry that will automatically negotiate the highest possible data rate and duplex operation possible with attached devices supporting the IEEE 802.3 Clause 28 auto-negotiation standard.

##### **3. Optical Ports:**

Ensure that all fiber-optic link ports operate at 1310 or 1550 nanometers in single mode. Provide fully functional ports with Type LC connectors and the optics for the optical ports. Do not use mechanical transfer registered jack (MTRJ) or ST type connectors.

Provide edge switches having a minimum of two optical 100 Base FX ports capable of transmitting data at 100 megabits per second. Ensure that each optical port consists of a pair of fibers, one fiber will transmit (TX) data and one fiber will receive (RX) data.

Provide 10/100/1000 Mbps optical ports that consist of fiber pairs, one fiber will transmit (TX) data and one fiber will receive (RX) data. Provide optical ports that meet the following minimum requirements:

- Optical receiver sensitivity: -32 dBm,
- Optical transmitter power: -15.5 dBm,
- Typical transmission distance: 40 km, and
- Operating wavelength: 1310 nm.

##### **4. Copper Ports:**

Provide an edge switch that includes a minimum of six copper ports. Provide Type RJ-45 copper ports and that auto-negotiate speed (i.e., 10/100 Base) and duplex (i.e., full or half). Ensure that all 10/100/1000 Base TX ports meet the specifications detailed in this section and are compliant with the IEEE 802.3 standard pinouts. Ensure that all Category 5e unshielded twisted pair/shielded twisted pair network cables are compliant with the EIA/TIA-568-B standard.

**5. Port Security:**

Ensure that the edge switch supports/complies with the following (remotely) minimum requirements:

- Ability to configure static MAC addresses,
- Ability to disable automatic address learning per ports, known hereafter as Secure Port. Secure Ports only forward, and
- Trap and alarm upon any unauthorized MAC address and shutdown for programmable duration. Port shutdown requires administrator to reset manually the port before communications are allowed.

**6. Network Capabilities:**

Provide the edge switch supports/complies with the following minimum requirements:

- Provide full implementation of IGMPv2 snooping (RFC 2236),
- Provide full implementation of SNMPv1, SNMPv2c, and/or SNMPv3,
- Capable of mirroring any port to any other port within the switch,
- Meet the IEEE 802.1Q (VLAN) standard per port for up to four VLANs,
- Meet the IEEE 802.3ad (Port Trunking) standard for a minimum of two groups of four ports,
- Telnet/CLI,
- HTTP (Embedded Web Server) with Secure Sockets Layer (SSL), and
- Full implementation of RFC 783 (TFTP) to allow remote firmware upgrades.

**7. Network Security:**

Provide the edge switch supports/complies with the following (remotely) minimum network security requirements:

- Multi-level user passwords,
- RADIUS centralized password management (IEEE 802.1X),
- SNMPv3 encrypted authentication and access security,
- Port security through controlling access by the users: ensure that the Ethernet edge switch has the capability to generate an alarm and shut down ports when an unauthorized user accesses the network,
- Support of remote monitoring (RMON) of the Ethernet agent, and
- Support of the TFTP and SNTP. Ensure that the Ethernet edge switch supports port mirroring for troubleshooting purposes when combined with a network analyzer.

**8. Environmental Requirements:**

Provide Ethernet edge switches that adhere to the following environmental constraints as defined in the environmental requirements section of the NEMA TS-2 standard if located within a climate-controlled environment:

- Operating temperature range: -30°F to 165°F,
- Storage temperature range: 14°F to 158°F, and
- Operating relative humidity range: 10% to 90%, non-condensing.

Verify that the Ethernet edge switch manufacturer certifies their device has successfully completed environmental testing as defined in the environmental requirements section of the NEMA TS 2 standard. Verify that vibration and shock resistance meet the requirements of Sections 2.1.9 and 2.1.10, respectively, of the NEMA TS 2 standard. Ensure that the Ethernet switch is protected from rain, dust, corrosive elements, and typical conditions found in a roadside environment.

The Ethernet switches shall meet or exceed the following environmental standards:

- IEEE 1613 (electric utility substations),
- IEC 6185003 (electric utility substations),
- IEEE 61800-3 (variable speed drive systems), and
- IEC 61000-6-2 (generic industrial).

**C. Central Digital Hardware Video Decoders****1. General**

Furnish digital hardware video decoder components that utilize the Moving Picture Experts Group's H.264 video compression technology in accordance with the International Organization for Standardization (ISO) and International Electrotechnical Commission (IEC) requirements detailed in the ISO/IEC 13818 and 14496-14 standards, respectively.

Furnish digital hardware video decoder components that are hardware-based network devices and that are card mounted and mount in a card cage.

Furnish digital hardware video decoders having a minimum of one serial data interface with connectors that conform to National Television System Committee (NTSC) standards.

**2. Serial Interface**

Furnish hardware-based digital video decoders having a serial data interface and connector that conforms to EIA-232/422/485 standards. Ensure that the serial interface supports EIA-232 as well as 2-wire and 4-wire EIA-422/485 connections. Ensure that the serial port supports data rates up to 115.2 Kbps. Serial interface parameters, such as data format, number of bits, handshaking, and parity, shall be software programmable through local connection to the digital video encoders and through connections over the network. The serial interface port may utilize RJ-45 connectors, D-sub connectors, or screw terminals.

**3. Network Interface**

Ensure that the digital hardware video decoder local area network (LAN) connection supports the requirements detailed in the IEEE 802.3 standard for 10/100 Ethernet connections.

Provide units having a minimum of one Ethernet port, which shall be a 10/100 Base-TX connection. Ensure that the connector complies with the EIA and Telecommunications Industry Association (TIA) requirements as detailed in the EIA/TIA-568-A standard. Provide copper based network interface ports that utilize RJ-45 connectors.

Ensure that all Category 5e unshielded twisted pair/shielded twisted pair network cables are compliant with the EIA/TIA-568-B standard. Ensure that the network communication conforms to User Datagram Protocol (UDP), Version 4 of the Internet Protocol (IP) and Version 2 of the Internet Group Multicast Protocol (IGMP).

#### **4. Video Interface**

Use digital hardware video decoders having one analog video interfaces and connectors that conform to standards. Ensure that the serial interfaces support EIA-232 as well as 2-wire and 4-wire EIA-422/485 connections. Ensure that the serial port(s) support data rates up to 115.2 Kbps. Serial interface parameters, such as data format, number of bits, handshaking, and parity, shall be software programmable through local connection to the digital video decoders and through connections over the network. Serial interface ports may utilize RJ-45 connectors, Dsub connectors, or screw terminals.

#### **5. Front Panel Status Indicators**

Ensure the digital hardware video decoders have light-emitting diode (LED) displays, liquid crystal displays (LCDs), or similar illuminated displays to configuration and management.

#### **D. Central Media Converter**

Furnish central media converters that serve as a wiring concentrator to provide connectivity of existing central DMS server with serial, EIA-232, compliant ports to the LAN, as shown on the Plans.

The central media converters shall have the following features:

- A minimum 10 Base-T port for connectivity to the core Ethernet switch.
- A minimum of four (4) EIA-232 serial ports, each of which shall support data rates up to 115.2 kbps.
- Multi-protocol support of LAT, Novell, IPX, Telnet 3270, and TCP/IP
- TCP/IP support of RLOGIN, Dynamic SLIP, PPP, BOOTP, TFTP and SNMP.
- Minimum 2 MB RAM.
- Standard 19" Equipment Rack-mountable.
- Contain all software and drivers required to support access of serial ports from servers and client workstations.

#### **E. Ethernet Cable**

Provide shielded Category 5 Enhanced (5e) Ethernet cable that complies with ANSI/TIA-568-A-5 standards for four-pair shielded twisted copper for Ethernet communications. The cable shall meet all of the mechanical requirements of ANSI/ICEA S-80-576 applicable to four-pair inside wiring cable for plenum or general cabling.

Furnish Ethernet cable meeting the following minimum performance requirements:

- Specified frequency range: 1-100 MHz
- Attenuation: 24 dB

- NEXT: 37.1 dB
- ACR: 3.1 dB
- ELFEXT: 17 dB
- Power-sum ELFEXT: 14.4 dB
- Return loss: 8 dB
- Propagation delay: 548 nsec
- Delay skew: 50 nsec

Furnish Ethernet cable meeting the following physical requirements:

- Jacket: PVC, UV resistant
- Insulation: Polyolefin
- Core: Gel-filled or flooded core
- Binder: Clear Mylar with 100% coverage
- Shield: Aluminum/Mylar with 100% coverage
- Drain Wire: 24 AWG, seven stranded tinned copper
- Conductors: Annealed bare copper
- Conductor size: 24 AWG

Provide RJ-45 connectors with gold wire conductors terminated according EIA/TIA-568-A/568-B standards. Provide connectors with eight contacts. Furnish connectors appropriately rated for the cable being installed. Provide cables with factory-installed connectors for interior cables.

Furnish Fast Ethernet patch cords meeting the following physical requirements:

- Minimum of five (5)-foot length,
- Category 5e,
- Factory pre-installed RJ-45 connectors on both ends,
- Molded anti-snap hoods over connectors, and
- Gold plated connectors.

Furnish Ethernet patch cords meeting the following minimum performance requirements:

- TIA/EIA-568-A-5, Additional Transmission Performance Specifications for 4-pair 100  $\Omega$  Enhanced Category 5e Cabling.
- Frequency Range: 1-100 MHz.
- Near-End Crosstalk (NEXT): 30.1 dB.
- Power-sum NEXT: 27.1 dB.
- Attenuation to Crosstalk Ratio (ACR): 6.1 dB.
- Power-sum ACR: 3.1 dB.



- Return Loss: 10 dB. and
- Propagation Delay: 548 nsec.

Provide 4-pair twisted copper Ethernet cable and connectors rated for an ambient operating temperature range of -30° to 165° F. Furnish factory pre-terminated/pre-connectorized Ethernet cables whenever possible. Provide factory pre-connectorized Ethernet cables for all cables that are less than or equal to 12 feet in length.

### **22.3. CONSTRUCTION METHODS**

#### **A. General**

Furnish media access control (MAC) addresses for all equipment utilized as part of this project. Affix MAC Address label to each device utilized. Furnish IP addresses for all equipment utilized as part of this project. Affix final IP address each device utilized. Use labels that do not smear or fade.

In field equipment cabinets, fully integrate new Ethernet switches with the fiber optic interconnect centers. Integrate all field equipment as call for.

Fully integrate LAN to accomplish local device failover and fault tolerance.

Fully integrate LAN equipment to provide virus protection, user authentication, and security functions to prevent unauthorized users and data from entering the LAN.

#### **B. Requirements Definition Document**

Prior to commencing work, the Contractor shall develop a Requirements Definition Document (RDD) that will form the basis for the overall network architecture and design.

- Complete description of the proposed implementation of the access, distribution and core layers for the network as described in the Plans and these Project Special Provisions
- Development of an IP Design Scheme with ranges assigned to each node to be integrated by the Contractor (address ranges, geographic distribution, standards for addresses within each cabinet)
- Proposed IP subnet definition and addressing including any and all masks
- Proposed IP multicast configuration including multicast routing (i.e., PIM sparse or dense) and Rendezvous Point (RP) designation as necessary
- Proposed recommendations for failover and redundancy including network device power, supervisor cards, and network ports
- Proposed configuration and guidelines for L3 routing (OSPF, VRRP, EIGRP, RIP, etc.);
- Proposed configuration and guidelines for Virtual LAN assignments including management VLANs, device VLANs and routing VLANs; and
- Proposed configuration and guidelines for L2 broadcast storm prevention, loop prevention and fault tolerance mechanisms. (Spanning Tree diagram with designated, blocking and forwarding ports indicated. Root bridge and backup root bridge must also be specified.) Incorporation of Multiple Spanning Tree Protocol.
- Proposed configuration and guidelines to mitigate common security threats such as denial of service, man in the middle, MAC/IP spoofing and brute force dictionary attacks.

- Proposed configuration and guidelines for 802.1p Class of Service (COS) queue assignments
- Proposed configuration and guidelines for specific port assignments on each of the L2 and L3 devices

The RDD shall be prepared and signed by a qualified networking professional (minimum CCNA or a manufacturer-approved equivalent based on the approved hardware vendor) and will be approved by the Engineer. The Qualified network professional will be present during the installation and testing of the local area network as well as during system testing.

### **C. Ethernet Edge Switch**

Install and integrate all field Ethernet switches at field locations as depicted in the diagrams and tables and called for in these Project Special Provisions. Integrate with equipment cabinet hardware and fiber optic communications equipment.

Provide inline surge protection for all Ethernet connections in field cabinets.

Ensure that the Regional ITS Engineer will be able to manage each Ethernet switch individually or as a group/cluster for switch configuration, performance monitoring, and troubleshooting. Note that these specifications require additional minimum management intelligence (i.e., Layer 2+) typical of most current industrial Ethernet deployments. Ensure that the edge switch includes Layer 2+ capability providing architecture standardization, open connectivity (i.e., interoperability), bandwidth management, rate limiting, security filtering, and general integration management of an advanced Ethernet switching architecture.

Mount the Ethernet switches inside each field cabinet using manufacturer-recommended or Engineer-approved attachment methods, attachment hardware, and fasteners. Ensure that the edge switch is mounted securely in the cabinet and is fully accessible by field technicians without blocking access to other equipment. Verify that fiber-optic jumpers consist of a length of cable that is connectorized on both ends, primarily used for interconnecting termination or patching facilities and/or equipment. Use fiber-optic jumpers that are factory assembled and connectorized and are certified by the fiber-optic jumpers' manufacturer to meet the relevant performance standards required below. Verify that network/field/data jumper cables meet all ANSI/EIA/TIA requirements for Category 5e 4-pair unshielded twisted pair cabling with stranded conductors and RJ45 connectors.

### **D. Central Digital Hardware Video Decoder**

Install the central digital video decoder units in the existing rack cabinet at the TRTMC as shown in the Plans. Integrate the decoder units with the rack cabinet power supply and UPS. Integrate the decoder with the existing core Ethernet switch. Integrate the analog video outputs with the inputs on the existing video matrix switch at the TRTMC.

### **E. Central Media Converter**

Install one multiple-port central media converter in the existing rack cabinet at the TRTMC. Integrate with the existing core Ethernet switch and existing DMS server to facilitate communications with the field DMS units.

### **F. Cellular Modem and Antenna**

Install a Department-furnished cellular telephone modem in each existing and new DMS cabinet on the project. Install the antenna on the cabinet. Connect the modem power supply to an available

receptacle inside the DMS cabinet. Connect the modem to the DMS controller using appropriate cables.

**Request cellular telephone modems and antennas from the Regional ITS Engineer a minimum of 8 weeks in advance of need.**

#### **G. Ethernet Cable**

Furnish all tools, equipment, materials, supplies, and hardware necessary to install a fully operational Ethernet cable system as depicted in the Plans. Install the Ethernet cable according to the latest version of the manufacturer's cable installation procedures and the industry-accepted installation standards, codes, and practices, or as directed by the Engineer.

Take all precautions necessary to ensure the Ethernet cable is not damaged during storage and installation. Do not step on the cable nor run over the cable with vehicles or equipment. Do not pull the cable over or around obstructions or along the ground.

Immediately cease work and notify the Engineer and the affected owner should damage to existing cables or equipment occur. Make the required repairs at no additional cost to the Department.

Install Ethernet cable in continuous lengths with no splices outside cabinets.

Cut cables to length to minimize coils of spare cable. Cut outer jacket and trim conductors per manufacturer's recommendations. Ensure all conductors extend to the end of the channel and make solid electrical contact with the gold connectors. Crimp the RJ-45 connector body to lock conductors in channels.

Install Ethernet patch cords between Ethernet patch panels and devices.

#### **22.4. MEASUREMENT AND PAYMENT**

*Ethernet Edge Switch* will be measured and paid as the actual number furnished, installed, integrated, and accepted. All SFP modules, optics, cabling, attenuators, configuration, and testing or other labor or materials required to install and integrate the Ethernet Switch will be considered incidental and not be paid for separately.

*Digital Hardware Video Decoder* will be measured and paid for as the actual number of units, furnished, installed, integrated, and accepted. All cabling and patch cables, integration, and configuration required to install the digital video decoder unit shall be incidental and not be paid for separately.

*Central Media Converter* will be measured and paid for as the actual number of units furnished, installed, integrated, and accepted. All cabling and patch cables, integration, and configuration required to install the media converter shall be incidental and not be paid for separately.

No separate measurement will be made for furnishing and installing SMFO jumpers, Ethernet cables, communication cables, Ethernet patch cables, electrical cables, labels, power supplies, power cords, adapters, mounting hardware, nuts, bolts, brackets, connectors, grounding equipment, and surge suppression as these will be considered incidental to the pay items listed above.

No separate measurement will be made for LAN integration or RDD development, as these will be considered incidental to the pay items listed above.

No measurement will be made of installing and testing Department-furnished cellular telephone modems and antennas, including any hardware and fasteners required to mount the antenna and any

required cables at new DMS locations as such work will be considered incidental to furnishing and installing each DMS.

Payment will be made under:

<b>Pay Item</b>	<b>Pay Unit</b>
Ethernet Edge Switch.....	Each
Digital Hardware Video Decoder .....	Each
Central Media Converter.....	Each

## 23. INTEGRATION AND CONFIGURATION

### 23.1. DESCRIPTION

Install and fully integrate new central equipment at the TRTMC. Fully configure existing central hardware and software at the TRTMC to establish communications with new CCTV and DMS devices.

Coordinate the working hours and building access for all central configuration activities with the Engineer.

### 23.2. CENTRAL INTEGRATION

Furnish media access control (MAC) addresses for all equipment utilized as part of this project. Affix MAC Address label to each device utilized. Furnish IP addresses for all equipment utilized as part of this project. Affix final IP address each device utilized. Use labels that do not smear or fade.

Install central video CODEC units, and terminal device servers in the existing rack cabinets at the TRTMC as shown on the Block Diagram in the Plans.

Integrate the existing core Ethernet switch with the existing fiber optic interconnect center such that the current communications topology is preserved. Configure the core Ethernet switch and ports as required to establish communications to field Ethernet switches.

Integrate the central video CODEC units with the core Ethernet switch and existing video matrix switch. Configure the video matrix switch to add the new CCTV devices as new inputs to the switch.

Configure the existing CCTV server to recognize the new CCTV units and process the video and control data for sharing with the TRTMC.

Integrate the serial device servers with the core Ethernet switch and existing DMS server.

Configure the existing DMS server to recognize the new DMS units and process control data for sharing with the TRTMC.

### 23.3. CENTRAL CONFIGURATION

The existing DMS central software that controls the DMS units at the TRTMC is Daktronic's Vanguard V4. Modify the existing DMS central software configuration at the TRTMC to display and map the new DMS units in the software GUI. Ensure that the software also allows for full communications and control of the DMS unit.

The existing CCTV central software that controls the existing video matrix switch at the TRTMC is Protronix's VideoPro. This software includes on-screen pan-tilt-zoom controls of each camera in the system. Modify the Protronix CCTV central software configuration at the TRTMC to display and map the new CCTV devices so that the CCTV video can be displayed on the existing monitors and display devices at the TRTMC.

Integrate the new CCTV units with NCDOT's regional video sharing and distribution system to allow for remote users to view and control the new CCTV units that terminate on the NCDOT analog video matrix switch through the Ethernet network connection between the remote user and the NCDOT VideoPro server at the TRTMC.

**23.4. MEASUREMENT AND PAYMENT**

*Integration and Configuration* will be measured and paid as a lump sum price. This item shall include the installation, testing, and all materials, equipment, labor, tools, storage, shipping, and incidentals necessary to complete the integration and configuration of CCTV and DMS devices with the existing systems at the TRTMC.

All cabling, labeling, sockets, or other accessories required to configure, integrate, and interconnect computer equipment shall be considered incidental and shall not be paid for separately.

All central equipment installed for communications to new CCTV and DMS units will be measured and paid for under the applicable Section of these Project Special Provisions.

Payment will be made under:

<b>Pay Item</b>	<b>Pay Unit</b>
Integration and Configuration.....	Lump Sum

## **24. TESTING & ACCEPTANCE**

### **24.1. GENERAL TEST PROCEDURE**

Test the DMS and CCTV systems in a series of design approval and functional tests. The results of each test must meet the specified requirements. These tests should not damage the equipment. The Engineer will reject equipment that fails to fulfill the requirements of any test. Resubmit rejected equipment after correcting non-conformities and re-testing; completely document all diagnoses and corrective actions. Modify all equipment furnished under this contract, without additional cost to the North Carolina Department of Transportation, to incorporate all design changes necessary to pass the required tests.

Provide 4 copies of all test procedures and requirements to the Engineer for review and approval at least 30 days prior to the testing start date.

Only use approved procedures for the tests. Include the following in the test procedures:

- A step-by-step outline of the test sequence, showing a test of every function of the equipment or system tested
- A description of the expected nominal operation, output, and test results, and the pass / fail criteria
- An estimate of the test duration and a proposed test schedule
- A data form to record all data and quantitative results obtained during the test
- A description of any special equipment, setup, manpower, or conditions required by the test

Provide all necessary test equipment and technical support. Use test equipment calibrated to National Institute of Standards and Technology (NIST) standards. Provide calibration documentation upon request.

Conform to these testing requirements and the requirements of these specifications. The Engineer will reject all equipment not tested according to these requirements. It is the Contractor's responsibility to ensure the system functions properly even after the Engineer accepts the test results.

Provide 4 copies of the quantitative test results and data forms containing all data taken, highlighting any non-conforming results and remedies taken, to the Engineer for approval. An authorized representative of the manufacturer must sign the test results and data forms.

### **24.2. DESIGN APPROVAL TESTS**

#### **A. DMS System**

Design Approval Tests are applicable to DMS systems not currently on the QPL.

The Design Approval Tests consists of all tests described in Section 2.2 "DMS Equipment Tests" of NEMA TS 4-2005 (Hardware Standards for Dynamic Message Signs with NTCIP Requirements). Perform all tests and submit certified results for review and approval.

**PROTOTYPE** – Manufacture a prototype DMS and controller of the type and size described in the Project Special Provisions. In the presence of the Engineer, test the prototype according to the Design Approval and Operational Tests. When all corrections and changes (if any) have been made,

the Department may accept the prototype DMS and controller as the physical and functional standard for the system furnished under this contract. You may use the prototype units on this project if, after inspection and rework (if necessary), they meet all physical and functional specifications. In the case of standard product line equipment, if the Contractor can provide test results certified by an independent testing facility as evidence of prior completion of successful design approval tests, then the Engineer may choose to waive these tests.

In each Design Approval Test, successfully perform the Functional Tests described below. Apply the extreme conditions to all associated equipment unless stated otherwise in these Project Special Provisions.

**B. CCTV System**

No design approval test is required.

**C. Fiber Optic Communications**

No design approval test is required.

**D. Central Hardware**

No design approval test is required.

**24.3. COMPATIBILITY TESTS**

**A. DMS System**

No compatibility test is required.

**B. CCTV System**

Compatibility Tests are applicable to CCTV cameras and video transceivers that the Contractor wishes to furnish but are of a different manufacturer or model series than the existing units in the field or existing units installed at the TRTMC. If required, the Compatibility Test shall be completed and accepted by the Engineer prior to approval of the material submittal.

The Compatibility Test shall be performed in a laboratory environment at a facility chosen by the Engineer based on the type of unit being tested. Provide notice to the Engineer with the material submitted that a Compatibility Test is requested. The notice shall include a detailed test plan that will show compatibility with existing equipment. The notice shall be given a minimum of 15 calendar days prior to the beginning of the Compatibility Test.

The Contractor shall provide, install, and integrate a full-functioning unit to be tested. The Department will provide access to existing equipment to facilitate these testing procedures. The Contractor is responsible for configuring proposed equipment at the TRTMC and proving compatibility. The Engineer will determine if the Compatibility Test was acceptable for each proposed device.

**C. Fiber Optic Communications**

No compatibility test is required.

**D. Central Hardware**

Compatibility Tests are applicable to central and field Ethernet switches that the Contractor wishes to furnish but are of a different manufacturer or model series than the existing units in the



field or existing units installed at the TRTMC. If required, the Compatibility Test shall be completed and accepted by the Engineer prior to approval of the material submittal.

The Compatibility Test shall be performed in a laboratory environment at a facility chosen by the Engineer based on the type of unit being tested. Provide notice to the Engineer with the material submitted that a Compatibility Test is requested. The notice shall include a detailed test plan that will show compatibility with existing equipment. The notice shall be given a minimum of 15 calendar days prior to the beginning of the Compatibility Test.

The Contractor shall provide, install, and integrate a full-functioning unit to be tested. The Department will provide access to existing equipment to facilitate these testing procedures. The Contractor is responsible for configuring proposed equipment at the TRTMC and proving compatibility. The Engineer will determine if the Compatibility Test was acceptable for each proposed device.

#### **24.4. OPERATIONAL FIELD TEST (ON-SITE COMMISSIONING)**

##### **A. DMS System**

Conduct an Operational Field Test of the DMS system installed on the project to exercise the normal operational functions of the equipment. The Operational Field Test will consist of the following tests as a minimum:

##### **1. Physical Examination**

Examine each piece of equipment to verify that the materials, design, construction, markings, and workmanship comply with the mechanical, dimensional, and assembly requirements of these Project Special Provisions.

Perform the following tests as a minimum:

- Verify that all surfaces are free of dents, scratches, weld burns, or abrasions. Round sharp edges and corners.
- Verify bend radius of cables is not excessive or could potentially cause damage.
- Verify all modules, lamps, and components are properly secured.
- Verify that there are no exposed live terminals.

##### **2. Continuity Tests**

Check the wiring to assure it conforms to the requirements of these Project Special Provisions.

##### **3. Functional Tests**

Perform the following functional tests:

- Start-up and operate the DMS locally using a laptop computer.
- Use automatic (photo-electric sensor controlled) DMS Control Software to switch between “dim”, “normal”, and “bright” light levels.
- Operate the DMS with all display elements flashing continuously for 10 minutes at the maximum flash rate.

- Exercise the DMS by displaying static messages, flashing messages, and alternating static and flashing message sequences.
- Automatic poll the DMS by the Control Software at various intervals and verify the data received by Control Software from DMS.
- Download and edit messages using Control Software.
- Execute status request on the DMS controller.
- Observe normal operations during uploading and downloading messages.
- Input and select messages from the sign controller's local user interface.
- Test sequence activation at chosen intervals.
- Display and verify all stored messages.
- Verify resumption of standard operation upon interruption of electrical power.
- Demonstrate detected failures and response functions.
- Demonstrate proper operation of the Failure Log.
- Set controller clock using the Control Software.
- Execute system shutdown using the Control Software and local user interface.
- Verify detection of a power failure in the DMS enclosure and the report feature of the failure to the Control Software.

Approval of Operational Field Test results does not relieve the Contractor to conform to the requirements in these Project Special Provisions. If the DMS system does not pass these tests, document a correction or substitute a new unit as approved by the Engineer. Re-test the system until it passes all requirements.

### **B. CCTV System**

Perform the following local operational field tests at the camera assembly field site in accordance with the test plans. A laptop computer shall provide camera control and positioning. After completing the installation of the camera assembly, including the camera hardware, video transceiver unit, power supply, and connecting cables:

- Furnish all equipment, appliances, and labor necessary to test the installed cable and to perform the following tests before any connections are made;
- Verify that physical construction has been completed;
- Inspect the quality and tightness of ground and surge protector connections;
- Check the power supply voltages and outputs;
- Connect devices to the power sources;
- Verify installation of specified cables and connections between the camera, PTZ, camera control receiver, and control cabinet;
- Perform the CCTV assembly manufacturer's initial power-on test in accordance with the manufacturer's recommendation;

- Set the camera IP address;
- Verify the presence and quality of the video image with a laptop computer and applicable video viewing software;
- Exercise the pan, tilt, zoom, focus, iris opening, and manual iris control selections, and the operation, preset positioning, and power on/off functions;
- Demonstrate the pan and tilt speeds and extent of movement to meet all applicable standards, specifications, and requirements;
- Verify proper voltage of all power supplies; and
- Interconnect the communication interface device with the communication network's assigned fiber-optic trunk cable and verify that there is a transmission LED illuminated.

Approval of Operational Field Test results does not relieve the Contractor to conform to the requirements in these Project Special Provisions. If the CCTV system does not pass these tests, document a correction or substitute a new unit as approved by the Engineer. Re-test the system until it passes all requirements.

### **C. Fiber Optic Communications**

Conduct optical time domain reflectometer (OTDR) tests on the cable on the reel and after the cable is installed and terminated. Provide written notification a minimum of ten days before beginning fiber-optic cable testing.

After splicing is completed, perform bi-directional OTDR tests on each fiber, including unused fibers, to ensure the following:

- Fusion splice loss does not exceed 0.05 dB,
- Terminations and connections have a loss of 0.5 dB or less, and
- Reflection loss is 40 dB or greater for each connector.

Install a 1000-foot pre-tested launch cable between the OTDR and fiber-optic cable to be tested.

If exceeded, remake splices until the loss falls below 0.05 dB. The Department will record each attempt for purposes of acceptance.

Furnish durable labeled plots and electronic copies on a CD or DVD of test results for each fiber including engineering calculations demonstrating that OTDR test results meet or exceed the attenuation requirements and that optical properties of the cable have not been impaired. Label all test results (plots and discs) with the manufacturer and model number of the OTDR testing equipment.

Provide a tabular summary or spreadsheet detailing and comparing the loss budget and actual loss calculations per link. Provide test results for fiber-optic cable that demonstrates the loss budget where the fiber originates and the point where the fiber meets an electronic device.

If any fiber exceeds the maximum allowable attenuation or if the fiber-optic properties of the cable have been impaired, take approved corrective action including replacement of complete segments of fiber-optic cable if required. Corrective action will be at no additional cost to the Department.

**D. Central Hardware**

The Contractor shall perform a Network System Test (NST) on the local area network. During the NST, the Contractor must demonstrate successful local operation of field equipment operating from the field Ethernet switches as well as successful control of the equipment from the TRTMC.

In the event of a failed NST, the Contractor, at his expense, must perform all necessary activities required to provide proper operation of the LAN, which can include full replacement of field equipment or cabling.

The Engineer or his representative will witness all NSTs. Documentation of all testing procedures and activities must be provided to the Engineer prior to full acceptance of the system ring.

**24.5. SYSTEM OPERATIONAL TEST**

All equipment install and software configuration provided in this project shall be completed and operational prior to the start of the system operational test. These test procedures shall demonstrate that all equipment is fully integrated and operational, and is properly controlling the system.

Submit a system acceptance test procedure to the Engineer for review and approval before any tests are to be conducted.

Submit a System Operational test plan a minimum of thirty (30) days prior to the scheduled start of the test. The test plan shall include columns for a description of the test, a summary of the test procedures, a column with sufficient space for comments and a status (pass/fail) column. The test plan will be reviewed by the Engineer, and either approve it or indicate changes that are required for approval. The Contractor shall then submit the revised test plan. This process shall be repeated until the Engineer is able to approve the test plan.

Repair or replace any component or software module that fails the System Operational Test. Retest repaired or replaced component(s) or software module.

The testing shall include, but not be limited to, the demonstration of an operator at a workstation in the TRTMC performing the following tasks:

- Ping all IP-addressed equipment
- View video streams from all CCTV cameras
- Pan, tilt, and zoom all CCTV cameras
- View the status of all DMS units
- Post and remove a test message on all DMS units

**24.6. 30-DAY OBSERVATION PERIOD**

The 30-Day Observation Period shall **NOT** be considered part of work to be completed by the project completion date.

Upon successful completion of all project work, the component tests, the System Test, and the correction of all deficiencies, including minor construction items, the 30-day Observation Period may commence. This observation consists of a 30-day period of normal, day-to-day operations of the new field equipment in operation with the new central equipment without any failures. The

purpose of this period is to ensure that all components of the system function in accordance with the Plans and these Project Special Provisions.

Respond to system or component failures (or reported failures) that occur during the 30-day Observation Period within twenty-four (24) hours. Correct said failures within forty-eight (48) hours. Any failure that affects a major system component as defined below for more than forty-eight (48) hours will suspend the timing of the 30-day Observation Period beginning at the time when the failure occurred. After the cause of such failures has been corrected, timing of the 30-day Observation Period will resume. System or component failures that necessitate a redesign of any component or failure in any of the major system components exceeding a total of three (3) occurrences will terminate the 30-day Observation Period and cause the 30-day Observation Period to be restarted from day zero when the redesigned components have been installed and/or the failures corrected. The major system components are:

- DMS Field Controller and Display Module
- CCTV Camera, PTZ, and Video Transceivers
- Fiber Optic Communications Cables and Splices
- Local Area Network including Ethernet switches

#### **24.7. FINAL ACCEPTANCE**

Final system acceptance is defined as the time when all work and materials described in the Plans and these Project Special Provisions have been furnished and completely installed by the Contractor; all parts of the work have been approved and accepted by the Engineer; and successful completion of the 30-day observation period.

The project will be ready for final acceptance upon the satisfactory completion of all tests detailed in this Section of the Project Special provisions; the rectification of all punch-list discrepancies; and the submittal of all project documentation.

#### **24.8. MEASUREMENT AND PAYMENT**

There will be no direct payment for the work covered in this section.

Payment for this work will be covered in the applicable sections of these Project Special Provisions at the contract unit price for other items furnished on this Project.

**SPECIAL PROVISIONS FOR PROTECTION OF RAILWAY INTEREST  
NORFOLK SOUTHERN RAILWAY COMPANY** 05/16

14 **INSURANCE:** State Project: U-2579C/Y-4809K County: Forsyth

A. In addition to any other forms of insurance or bonds required under the terms of the contract and specifications, the Prime Contractor will be required to provide coverage conforming to the requirements of the Federal-Aid Policy Guide outlined under 23 CFR 646A for all work to be performed on Railroad right(s) of way by carrying insurance of the following kinds and amounts:

1. **CONTRACTOR'S COMMERCIAL GENERAL LIABILITY INSURANCE:**

The Contractor shall furnish an original and one copy of the certificate of insurance and one certified copy of the policy to the Railroad and Department as evidence that, with respect to the operations he performs on railroad right of way, he carries regular Commercial General Liability Insurance having a combined single limit of not less than \$2,000,000 per occurrence for all loss, damage, cost and expense, including attorneys' fees, arising out of bodily injury liability and property damage liability during the policy period. Said policy shall include explosion, collapse, and underground hazard (XCU) coverage, **shall be endorsed to name Railroad specified in item A.2.c. below as an additional insured, and shall include a severability of interests provision.** Also, Automobile Liability Insurance with a combined single limit of not less than \$1,000,000 each occurrence for injury to or death of persons and damage to or loss or destruction of property. **Said policy or policies shall be endorsed to name Railroad specified in item A.2.c. below both as the certificate holder and as an additional insured and shall include a severability of interests provision;**

2. **RAILROAD PROTECTIVE LIABILITY INSURANCE:**

The Contractor shall furnish to the Railroad and Department an original and one duplicate of the Railroad Protective Liability Insurance having a combined single limit of not less than \$2,000,000 each occurrence and \$6,000,000 in the aggregate applying separately to each annual period. If the project involves track over which passenger trains operate, the insurance limits required are not less than a combined single limit of \$5,000,000 each occurrence and \$10,000,000 in the aggregate applying separately to each annual period. Said policy shall provide coverage for all loss, damage or expense arising from bodily injury and property damage liability, and physical damage to property attributed to acts or omissions at the job site.

The standards for the Railroad Protective Liability Insurance are as follows:

- a. The insurer must be rated A- or better by A.M. Best Company, Inc.
- b. NOTE: NS does not accept from insurers Chartis (AIG or Affiliated Company including Lexington Insurance Company), Hudson Group or Liberty or

Affiliated Company, American Contractors Insurance Company and Erie Insurance Company including Erie Insurance Exchange and Erie Indemnity Company.

- c. The policy must be written using one of the following combinations of Insurance Services Office (“ISO”) Railroad Protective Liability Insurance Form Numbers:
- (1) CG 00 35 01 96 and CG 28 31 10 93; or
  - (2) CG 00 35 07 98 and CG 28 31 07 98; or
  - (3) CG 00 35 10 01; or
  - (4) CG 00 35 12 04; or
  - (5) CG 00 35 12 07; or
  - (6) CG 00 35 04 13.

- d. The named insured shall read:

Norfolk Southern Railway Company  
Three Commercial Place  
Norfolk, Virginia 23510-2191  
Attn: Scott Dickerson, Director Risk Management

(NOTE: NS does not share coverage on RRPL with any other entity on this policy)

- e. The description of operations must appear on the Declarations, must match the project description in this agreement, and must include the appropriate Department project and contract identification numbers.

The Description and Designation shall read: All construction within NS right of way in the vicinity of Northampton Road and Old Walkertown Road for NCDOT project U-2579C/Y-4809K in Forsyth County, NC.

- f. The job location must appear on the Declarations and must include the city, state, and appropriate highway name/number.

Note: Do not include any references to milepost, valuation station, or mile marker on the insurance policy.

- g. The name and address of the prime contractor must appear on the Declarations.
- h. The name and address of the Department must be identified on the Declarations as the “Involved Governmental Authority or Other Contracting Party.”
- i. Endorsements/forms that are required are:
- (1) Physical Damage to Property Amendment
  - (2) Terrorism Risk Insurance Act (TRIA) coverage must be included
- j. Other endorsements/forms that will be accepted are:
- (1) Broad Form Nuclear Exclusion – Form IL 00 21
  - (2) 30-day Advance Notice of Non-renewal or cancellation
  - (3) 60- day written notice be given the Department prior to cancellation or change
  - (4) Quick Reference or Index Form CL/IL 240

- k. Endorsements/forms that are **NOT** acceptable are:
- (1) Any Pollution Exclusion Endorsement except CG 28 31
  - (2) Any Punitive or Exemplary Damages Exclusion
  - (3) Known injury or Damage Exclusion form CG 00 59
  - (4) Any Common Policy Conditions form
  - (5) Any Endorsement that limits or excludes Professional Liability coverage
  - (6) A Non-Cumulation of Liability or Pyramiding of Limits Endorsement
  - (7) An Endorsement that excludes TRIA coverage
  - (8) A Sole Agent Endorsement
  - (9) Any type of deductible endorsement or amendment
  - (10) Any other endorsement/form not specifically authorized in item no. 2.h above.

B. If any part of the work is sublet, similar insurance, and evidence thereof as specified in A.1 above, shall be provided by or on behalf of the subcontractor to cover its operations on Railroad's right of way

C All insurance required under the preceding subsection A shall be underwritten by insurers and be of such form and content, as may be acceptable to the Company. Prior to entry on Railroad right-of-way, the original Railroad Protective Liability Insurance Policy shall be submitted by the Prime Contractor to the Department at the address below for its review and transmittal to the Railroad. In addition, certificates of insurance evidencing the Prime Contractor's and any subcontractors' Commercial General Liability Insurance shall be issued to the Railroad and the Department at the addresses below, and forwarded to the Department for its review and transmittal to the Railroad. The certificates of insurance shall state that the insurance coverage will not be suspended, voided, canceled, or reduced in coverage or limits without (30) days advance written notice to Railroad and the Department. No work will be permitted by Railroad on its right-of-way until it has reviewed and approved the evidence of insurance required herein.

DEPARTMENT:

NCDOT Rail Division  
 1556 Mail Service Center  
 Raleigh NC 27699-1556  
 Attn: Meredith McLamb

RAILROAD:

Risk Management  
 Norfolk Southern Railway Company  
 Three Commercial Place  
 Norfolk, Virginia 23510-2191

D The insurance required herein shall not limit the obligations of Department or its Contractors under the terms of this agreement.

E. Submission Requirements

1. Railroad will only accept initial insurance submissions via US Mail or Overnight carrier to the address noted in C above. Railroad will NOT accept initial insurance submissions via email or faxes. Please provide point of contact information with the submission including a phone number and email address.

2. Railroad requires the following two (2) forms of insurance in the initial insurance submission to be submitted under a cover letter providing details of the project and contact information:



a. The full original or certified true countersigned copy of the railroad protective liability insurance policy in its entirety inclusive of all declarations, schedule of forms and endorsements along with the policy forms and endorsements.

b. The Contractor’s commercial general, automobile, and workers’ compensation liability insurance certificate of liability insurance evidencing a combined single limit of a minimum of \$2M per occurrence of general and \$1M per occurrence of automobile liability insurance naming Norfolk Southern Railway Company, Three Commercial Place, Norfolk, VA 23510 as the certificate holder and as an additional insured on both the general and automobile liability insurance policy.

3. It should be noted that the Railroad does not accept notation of Railroad Protective Insurance on a certificate of liability insurance form or Binders as Railroad must have the full original countersigned policy. Further, please note that mere receipt of the policy is not the only issue but review for compliance. Due to the number of projects system-wide, it typically takes a minimum of 30-45 days for the Railroad to review.

15. FAILURE TO COMPLY:

A. In the event the Contractor violates or fails to comply with any of the requirements of these Special Provisions:

- (1) The Railroad Engineer may require that the Contractor vacate Railroad property.
- (2) The Engineer may withhold all monies due the Contractor on monthly statements.

Any such orders shall remain in effect until the Contractor has remedied the situation to the satisfaction of the Railroad Engineer and the Engineer.

16. PAYMENT FOR COST OF COMPLIANCE:

A. No separate payment will be made for any extra cost incurred on account of compliance with these special provisions. All such cost shall be included in prices bid for other items of the work as specified in the payment items.

RAILROAD SITE DATA:

The following information is provided as a convenience to the Contractor. This information is subject to change and the Contractor should contact the Railroad to verify the accuracy. Since this information is shown as a convenience to the Contractor but is subject to change, the Contractor shall have no claims whatsoever against either the Railroad or the Department of Transportation for any delays or additional costs incurred based on changes in this information.

Number of tracks	-	<u>1</u>
Number of trains per day	-	<u>10 (freight)</u>
Maximum speed of trains	-	<u>35 mph</u>

## Project Special Provisions Structures and Culverts

### Table of Contents

			<b>Page #</b>
Placing Load on Structure Members	(11-27-12)	-----	ST-2
Steel Reinforced Elastomeric Bearings	(6-22-16)	-----	ST-2
Thermal Sprayed Coatings (Metallization)	(9-30-11)	-----	ST-2
Falsework and Formwork	(4-5-12)	-----	ST-6
Submittal of Working Drawings	(6-28-16)	-----	ST-13
Crane Safety	(8-15-05)	-----	ST-19
Grout for Structures	(9-30-11)	-----	ST-20
Embedded Clips for Prestressed Concrete Girders	(6-22-16)	-----	ST-22

For Piles and Drilled Piers, see Geotechnical special provisions.



7/10/2017

DocuSigned by:

*A. Keith Paschal*

F8B6AD6DB2FC48F...

## ST-2

Project U-2579C

Forsyth County

### **PLACING LOAD ON STRUCTURE MEMBERS**

**(11-27-12)**

The 2012 Standard Specifications shall be revised as follows:

In **Section 420-20 – Placing Load on Structure Members** replace the first sentence of the fifth paragraph with the following:

Do not place vehicles or construction equipment on a bridge deck until the deck concrete develops the minimum specified 28 day compressive strength and attains an age of at least 7 curing days.

### **STEEL REINFORCED ELASTOMERIC BEARINGS**

**(6-22-16)**

The 2012 Standard Specifications shall be revised as follows:

In **Section 1079-2(A) – Elastomeric Bearings** add the following after the second paragraph:

Internal holding pins are required for all shim plates when the contract plans indicate the structure contains the necessary corrosion protection for a corrosive site.

Repair laminated (reinforced) bearing pads utilizing external holding pins via vulcanization. Submit product data for repair material and a detailed application procedure to the Materials and Tests Unit for approval before use and annually thereafter.

### **THERMAL SPRAYED COATINGS (METALLIZATION)**

**(9-30-11)**

#### **DESCRIPTION**

Apply a thermal sprayed coating (TSC) and sealer to metal surfaces as specified herein when called for on the plans or by other Special Provisions, or when otherwise approved by the Engineer in accordance with the SSPC-CS 23.00/AWS C2.23/NACE No. 12 Specification. Only Arc Sprayed application methods are used to apply TSC coatings, the Engineer must approve other methods of application.

#### **QUALIFICATIONS**

Only use NCDOT approved TSC Contractors meeting the following requirements:

1. The capability of blast cleaning steel surfaces to SSPC SP-5 and SP-10 Finishes.
2. Employ Spray Operator(s) qualified in accordance with AWS C.16/C2.16M2002 and Quality Control Inspector(s) who have documented training in the applicable test procedures of ASTM D-3276 and SSPC-CS 23.00.

A summary of the contractor's related work experience and the documents verifying each Spray Operator's and Quality Control Inspector's qualifications are submitted to the Engineer before any work is performed.

# ST-3

## MATERIALS

Provide wire in accordance with the metallizing equipment manufacturer's recommendations. Use the wire alloy specified on the plans which meets the requirements in Annex C of the SSPC-CS 23.00 Specification. Have the contractor provide a certified analysis (NCDOT Type 2 Certification) for each lot of wire material.

Apply an approved sealer to all metallized surfaces in accordance with Section 9 of SSPC- CS 23. The sealer must either meet SSPC Paint 27 or is an alternate approved by the Engineer.

## SURFACE PREPARATION AND TSC APPLICATION

Grind flame cut edges to remove the carbonized surface prior to blasting. Bevel all flame cut edges in accordance with Article 442-10(D) regardless of included angle. Blast clean surfaces to be metallized with grit or mineral abrasive in accordance with Steel Structures Painting Council SSPC SP-5/10(as specified) to impart an angular surface profile of 2.5 - 4.0 mils. Surface preparation hold times are in accordance with Section 7.32 of SSPC-CS 23. If flash rusting occurs prior to metallizing, blast clean the metal surface again. Apply the thermal sprayed coating only when the surface temperature of the steel is at least 5°F above the dew point.

At the beginning of each work period or shift, conduct bend tests in accordance with Section 6.5 of SSPC-CS 23.00. Any disbonding or delamination of the coating that exposes the substrate requires corrective action, additional testing, and the Engineer's approval before resuming the metallizing process.

Apply TSC with the alloy to the thickness specified on the plans or as provided in the table below. All spot results (the average of 3 to 5 readings) must meet the minimum requirement. No additional tolerance (as allowed by SSPC PA-2) is permitted. (For Steel Beams: For pieces with less than 200 ft<sup>2</sup> measure 2 spots/surface per piece and for pieces greater than 200 ft<sup>2</sup> add 1 additional spots/surface for each 500 ft<sup>2</sup>).

<b>Application</b>	<b>Thickness</b>	<b>Alloy</b>	<b>Seal Coat</b>
Pot Bearings	8 mil	85/15 Zinc (W-Zn-Al-2)	0.5 mil
Armored Joint Angles	8 mil	85/15 Zinc (W-Zn-Al-2)	0.5 mil
Modular Joints	8 mil	99.99% Zn (W-Zn-1)	0.5 mil
Expansion Joint Seals	8 mil	99.99% Zn (W-Zn-1)	0.5 mil
Optional Disc Bearings	8 mil	85/15 Zinc (W-Zn-Al-2)	0.5 mil

When noted on the plans or as specified in the above chart, apply the sealer to all metallized surfaces in accordance with the manufacturer's recommendations and these provisions. Apply the seal coat only when the air temperature is above 40°F

# ST-4

Project U-2579C

Forsyth County

and the surface temperature of the steel is at least 5°F above the dew point. If the sealer is not applied within eight hours after the final application of TSC, the applicator verifies acceptable TSC surfaces and obtains approval from the Engineer before applying the sealer.

## INSPECTION FREQUENCY

The TSC Contractor must conduct the following tests at the specified frequency and the results documented in a format approved by the Engineer.

Test/Standard	Location	Frequency	Specification
Ambient Conditions	Site	Each Process	5°F above the dew point
Abrasive Properties	Site	Each Day	Size, angularity, cleanliness
Surface Cleanliness SSPC Vis 1	All Surfaces	Visual All Surfaces	SSPC-SP-10 Atmospheric Service SSPC-SP - 5 Immersion Service
Surface Profile ASTM D-4417 Method C	Random Surfaces	3 per 500 ft <sup>2</sup>	2.5 - 4.0 mils
Bend Test SSPC-CS 23.00	Site	5 per shift	Pass Visual
Thickness SSPC PA-2R SSPC-CS 23.00	Each Surface	Use the method in PA-2 Appendix 3 for Girders and Appendix 4 for frames and miscellaneous steel. See Note 1.	Zn - 8 mils minimum Al - 8 mils minimum Zn Al - 8 mils minimum Areas with more than twice the minimum thickness are inspected for compliance to the adhesion and cut testing requirements of this specification.
Adhesion ASTM 4541	Random Surfaces Splice Areas	1 set of 3 per 500 ft <sup>2</sup>	Zn > 500 psi Al > 1000 psi Zn Al > 750 psi
Cut Test - SSPC-CS 23.00	Random Surfaces	3 sets of 3 per 500 ft <sup>2</sup>	No peeling or delamination
Job Reference Std. SSPC-CS 23.00	Site	1 per job	Meets all the above requirements

## REPAIRS

All Repairs are to be performed in accordance with the procedures below, depending on whether the repair surface is hidden or exposed. As an exception to the following, field welded splices on joint angles and field welding bearing plates to girders may be repaired in accordance with the procedures for hidden surfaces.

# ST-5

Project U-2579C

Forsyth County

## **For hidden surfaces (including but not limited to interior girders, interior faces of exterior girders, and below-grade sections of piles):**

1. Welding of metallized surfaces may be performed only if specifically permitted by the Engineer. Remove metallizing at the location of field welds by blast cleaning (SSPC SP-6 finish), or hand (SSPC SP-2 finish) or power tool cleaning (SSPC SP-3 finish) just prior to welding. Clean sufficiently to prevent contamination of the weld. All repairs to welded connections are metallized in accordance with SSPC CS 23.00.
2. Minor areas less than or equal to 0.1 ft<sup>2</sup> exposing the substrate are metallized in accordance with SSPC CS 23.00 or painted in accordance with ASTM A780, "Repair of Damaged and Uncoated Areas of Hot Dip Galvanized Coatings."
3. Large areas greater than 0.1 ft<sup>2</sup> exposing the substrate are metallized in accordance with SSPC CS 23.00.
4. Damaged (burnished) areas not exposing the substrate with less than the specified coating thickness are metallized in accordance with SSPC CS 23.00 or painted in accordance with ASTM A780, "Repair of Damaged and Uncoated Areas of Hot Dip Galvanized Coatings."
5. Damaged (burnished) areas not exposing the substrate with more than the specified coating thickness are not repaired.
6. Defective coating is repaired by either method 2 or 3 depending on the area of the defect.

## **For Exposed Surfaces (including but not limited to exterior faces of exterior girders and above-grade sections of piles):**

1. Welding of metallized surfaces may be performed only if specifically permitted by the Engineer. Remove metallization at the location of field welds by blast cleaning (SSPC SP-6 finish), or hand (SSPC SP-2 finish) or power tool cleaning (SSPC SP-3 finish) just prior to welding. Clean sufficiently to prevent contamination of the weld. All repairs to welded connections are metallized in accordance with SSPC CS 23.00.
2. All areas exposing the substrate are metallized in accordance with SSPC CS 23.00
3. Defective coating is repaired by either method 2 or 3 depending on the area of the defect.

## **TWELVE MONTH OBSERVATION PERIOD**

The contractor maintains responsibility for the coating system for a twelve (12) month observation period beginning upon the satisfactory completion of all the work required in the plans or as directed by the engineer. The contractor must guarantee the coating system under the payment and performance bond (refer to Article 109-10). To successfully complete the observation period, the coating system must meet the following requirements after twelve(12) months service:

# ST-6

Project U-2579C

Forsyth County

- No visible rust, contamination or application defect is observed in any coated area.
- Painted surfaces have a uniform color and gloss.
- Surfaces have an adhesion of no less than 500 psi when tested in accordance with ASTM D-4541.

## **BASIS OF PAYMENT**

The contract price bid for the bridge component to which the coating is applied will be full compensation for the thermal sprayed coating.

## **FALSEWORK AND FORMWORK**

**(4-5-12)**

### **1.0 DESCRIPTION**

Use this Special Provision as a guide to develop temporary works submittals required by the Standard Specifications or other provisions; no additional submittals are required herein. Such temporary works include, but are not limited to, falsework and formwork.

Falsework is any temporary construction used to support the permanent structure until it becomes self-supporting. Formwork is the temporary structure or mold used to retain plastic or fluid concrete in its designated shape until it hardens. Access scaffolding is a temporary structure that functions as a work platform that supports construction personnel, materials, and tools, but is not intended to support the structure. Scaffolding systems that are used to temporarily support permanent structures (as opposed to functioning as work platforms) are considered to be falsework under the definitions given. Shoring is a component of falsework such as horizontal, vertical, or inclined support members. Where the term “temporary works” is used, it includes all of the temporary facilities used in bridge construction that do not become part of the permanent structure.

Design and construct safe and adequate temporary works that will support all loads imposed and provide the necessary rigidity to achieve the lines and grades shown on the plans in the final structure.

### **2.0 MATERIALS**

Select materials suitable for temporary works; however, select materials that also ensure the safety and quality required by the design assumptions. The Engineer has authority to reject material on the basis of its condition, inappropriate use, safety, or nonconformance with the plans. Clearly identify allowable loads or stresses for all materials or manufactured devices on the plans. Revise the plan and notify the Engineer if any change to materials or material strengths is required.

**3.0 DESIGN REQUIREMENTS**

**A. Working Drawings**

Provide working drawings for items as specified in the contract, or as required by the Engineer, with design calculations and supporting data in sufficient detail to permit a structural and safety review of the proposed design of the temporary work.

On the drawings, show all information necessary to allow the design of any component to be checked independently as determined by the Engineer.

When concrete placement is involved, include data such as the drawings of proposed sequence, rate of placement, direction of placement, and location of all construction joints. Submit the number of copies as called for by the contract.

When required, have the drawings and calculations prepared under the guidance of, and sealed by, a North Carolina Registered Professional Engineer who is knowledgeable in temporary works design.

If requested by the Engineer, submit with the working drawings manufacturer’s catalog data listing the weight of all construction equipment that will be supported on the temporary work. Show anticipated total settlements and/or deflections of falsework and forms on the working drawings. Include falsework footing settlements, joint take-up, and deflection of beams or girders.

As an option for the Contractor, overhang falsework hangers may be uniformly spaced, at a maximum of 36 inches, provided the following conditions are met:

Member Type (PCG)	Member Depth, (inches)	Max. Overhang Width, (inches)	Max. Slab Edge Thickness, (inches)	Max. Screenshot Wheel Weight, (lbs.)	Bracket Min. Vertical Leg Extension, (inches)
II	36	39	14	2000	26
III	45	42	14	2000	35
IV	54	45	14	2000	44
MBT	63	51	12	2000	50
MBT	72	55	12	1700	48

Overhang width is measured from the centerline of the girder to the edge of the deck slab.

For Type II, III & IV prestressed concrete girders (PCG), 45-degree cast-in-place half hangers and rods must have a minimum safe working load of 6,000 lbs.

For MBT prestressed concrete girders, 45-degree angle holes for falsework hanger rods shall be cast through the girder top flange and located, measuring



## ST-8

Project U-2579C

Forsyth County

along the top of the member, 1'-2 1/2" from the edge of the top flange. Hanger hardware and rods must have a minimum safe working load of 6,000 lbs.

The overhang bracket provided for the diagonal leg shall have a minimum safe working load of 3,750 lbs. The vertical leg of the bracket shall extend to the point that the heel bears on the girder bottom flange, no closer than 4 inches from the bottom of the member. However, for 72-inch members, the heel of the bracket shall bear on the web, near the bottom flange transition.

Provide adequate overhang falsework and determine the appropriate adjustments for deck geometry, equipment, casting procedures and casting conditions.

If the optional overhang falsework spacing is used, indicate this on the falsework submittal and advise the girder producer of the proposed details. Failure to notify the Engineer of hanger type and hanger spacing on prestressed concrete girder casting drawings may delay the approval of those drawings.

Falsework hangers that support concentrated loads and are installed at the edge of thin top flange concrete girders (such as bulb tee girders) shall be spaced so as not to exceed 75% of the manufacturer's stated safe working load. Use of dual leg hangers (such as Meadow Burke HF-42 and HF-43) are not allowed on concrete girders with thin top flanges. Design the falsework and forms supporting deck slabs and overhangs on girder bridges so that there will be no differential settlement between the girders and the deck forms during placement of deck concrete.

When staged construction of the bridge deck is required, detail falsework and forms for screed and fluid concrete loads to be independent of any previous deck pour components when the mid-span girder deflection due to deck weight is greater than 3/4".

Note on the working drawings any anchorages, connectors, inserts, steel sleeves or other such devices used as part of the falsework or formwork that remains in the permanent structure. If the plan notes indicate that the structure contains the necessary corrosion protection required for a Corrosive Site, epoxy coat, galvanize or metalize these devices. Electroplating will not be allowed. Any coating required by the Engineer will be considered incidental to the various pay items requiring temporary works.

Design falsework and formwork requiring submittals in accordance with the 1995 AASHTO *Guide Design Specifications for Bridge Temporary Works* except as noted herein.

1. Wind Loads

Table 2.2 of Article 2.2.5.1 is modified to include wind velocities up to 110 mph. In addition, Table 2.2A is included to provide the maximum wind speeds by county in North Carolina.

**Table 2.2 - Wind Pressure Values**

Height Zone feet above ground	Pressure, lb/ft <sup>2</sup> for Indicated Wind Velocity, mph				
	70	80	90	100	110
0 to 30	15	20	25	30	35
30 to 50	20	25	30	35	40
50 to 100	25	30	35	40	45
over 100	30	35	40	45	50

2. Time of Removal

The following requirements replace those of Article 3.4.8.2.

Do not remove forms until the concrete has attained strengths required in Article 420-16 of the Standard Specifications and these Special Provisions.

Do not remove forms until the concrete has sufficient strength to prevent damage to the surface.

# ST-10

Project U-2579C

Forsyth County

**Table 2.2A - Steady State Maximum Wind Speeds by Counties in North Carolina**

COUNTY	25 YR (mph)	COUNTY	25 YR (mph)	COUNTY	25 YR (mph)
Alamance	70	Franklin	70	Pamlico	100
Alexander	70	Gaston	70	Pasquotank	100
Alleghany	70	Gates	90	Pender	100
Anson	70	Graham	80	Perquimans	100
Ashe	70	Granville	70	Person	70
Avery	70	Greene	80	Pitt	90
Beaufort	100	Guilford	70	Polk	80
Bertie	90	Halifax	80	Randolph	70
Bladen	90	Harnett	70	Richmond	70
Brunswick	100	Haywood	80	Robeson	80
Buncombe	80	Henderson	80	Rockingham	70
Burke	70	Hertford	90	Rowan	70
Cabarrus	70	Hoke	70	Rutherford	70
Caldwell	70	Hyde	110	Sampson	90
Camden	100	Iredell	70	Scotland	70
Carteret	110	Jackson	80	Stanley	70
Caswell	70	Johnston	80	Stokes	70
Catawba	70	Jones	100	Surry	70
Cherokee	80	Lee	70	Swain	80
Chatham	70	Lenoir	90	Transylvania	80
Chowan	90	Lincoln	70	Tyrell	100
Clay	80	Macon	80	Union	70
Cleveland	70	Madison	80	Vance	70
Columbus	90	Martin	90	Wake	70
Craven	100	McDowell	70	Warren	70
Cumberland	80	Mecklenburg	70	Washington	100
Currituck	100	Mitchell	70	Watauga	70
Dare	110	Montgomery	70	Wayne	80
Davidson	70	Moore	70	Wilkes	70
Davie	70	Nash	80	Wilson	80
Duplin	90	New Hanover	100	Yadkin	70
Durham	70	Northampton	80	Yancey	70
Edgecombe	80	Onslow	100		
Forsyth	70	Orange	70		

## B. Review and Approval

The Engineer is responsible for the review and approval of temporary works' drawings.

Submit the working drawings sufficiently in advance of proposed use to allow for their review, revision (if needed), and approval without delay to the work.

The time period for review of the working drawings does not begin until complete drawings and design calculations, when required, are received by the Engineer.

Do not start construction of any temporary work for which working drawings are required until the drawings have been approved. Such approval does not relieve the Contractor of the responsibility for the accuracy and adequacy of the working drawings.

## 4.0 CONSTRUCTION REQUIREMENTS

All requirements of Section 420 of the Standard Specifications apply.

Construct temporary works in conformance with the approved working drawings. Ensure that the quality of materials and workmanship employed is consistent with that assumed in the design of the temporary works. Do not weld falsework members to any portion of the permanent structure unless approved. Show any welding to the permanent structure on the approved construction drawings.

Provide tell-tales attached to the forms and extending to the ground, or other means, for accurate measurement of falsework settlement. Make sure that the anticipated compressive settlement and/or deflection of falsework does not exceed 1 inch. For cast-in-place concrete structures, make sure that the calculated deflection of falsework flexural members does not exceed 1/240 of their span regardless of whether or not the deflection is compensated by camber strips.

### A. Maintenance and Inspection

Inspect and maintain the temporary work in an acceptable condition throughout the period of its use. Certify that the manufactured devices have been maintained in a condition to allow them to safely carry their rated loads. Clearly mark each piece so that its capacity can be readily determined at the job site.

Perform an in-depth inspection of an applicable portion(s) of the temporary works, in the presence of the Engineer, not more than 24 hours prior to the beginning of each concrete placement. Inspect other temporary works at least once a month to ensure that they are functioning properly. Have a North Carolina Registered Professional Engineer inspect the cofferdams, shoring, sheathing,

support of excavation structures, and support systems for load tests prior to loading.

## B. Foundations

Determine the safe bearing capacity of the foundation material on which the supports for temporary works rest. If required by the Engineer, conduct load tests to verify proposed bearing capacity values that are marginal or in other high-risk situations.

The use of the foundation support values shown on the contract plans of the permanent structure is permitted if the foundations are on the same level and on the same soil as those of the permanent structure.

Allow for adequate site drainage or soil protection to prevent soil saturation and washout of the soil supporting the temporary works supports.

If piles are used, the estimation of capacities and later confirmation during construction using standard procedures based on the driving characteristics of the pile is permitted. If preferred, use load tests to confirm the estimated capacities; or, if required by the Engineer conduct load tests to verify bearing capacity values that are marginal or in other high risk situations.

The Engineer reviews and approves the proposed pile and soil bearing capacities.

## **5.0 REMOVAL**

Unless otherwise permitted, remove and keep all temporary works upon completion of the work. Do not disturb or otherwise damage the finished work.

Remove temporary works in conformance with the contract documents. Remove them in such a manner as to permit the structure to uniformly and gradually take the stresses due to its own weight.

## **6.0 METHOD OF MEASUREMENT**

Unless otherwise specified, temporary works will not be directly measured.

## **7.0 BASIS OF PAYMENT**

Payment at the contract unit prices for the various pay items requiring temporary works will be full compensation for the above falsework and formwork.

## **SUBMITTAL OF WORKING DRAWINGS**

**(6-28-17)**

### **1.0 GENERAL**

Submit working drawings in accordance with Article 105-2 of the *Standard Specifications* and this provision. For this provision, “submittals” refers to only those listed in this provision. The list of submittals contained herein does not represent a list of required submittals for the project. Submittals are only necessary for those items as required by the contract. Make submittals that are not specifically noted in this provision directly to the Engineer. Either the Structures Management Unit or the Geotechnical Engineering Unit or both units will jointly review submittals.

If a submittal contains variations from plan details or specifications or significantly affects project cost, field construction or operations, discuss the submittal with and submit all copies to the Engineer. State the reason for the proposed variation in the submittal. To minimize review time, make sure all submittals are complete when initially submitted. Provide a contact name and information with each submittal. Direct any questions regarding submittal requirements to the Engineer, Structures Management Unit contacts or the Geotechnical Engineering Unit contacts noted below.

In order to facilitate in-plant inspection by NCDOT and approval of working drawings, provide the name, address and telephone number of the facility where fabrication will actually be done if different than shown on the title block of the submitted working drawings. This includes, but is not limited to, precast concrete items, prestressed concrete items and fabricated steel or aluminum items.

### **2.0 ADDRESSES AND CONTACTS**

For submittals to the Structures Management Unit, use the following addresses:

Via US mail:

Mr. B. C. Hanks, P. E.  
State Structures Engineer  
North Carolina Department  
of Transportation  
Structures Management Unit  
1581 Mail Service Center  
Raleigh, NC 27699-1581

Attention: Mr. J. L. Bolden, P. E.  
E.

Via other delivery service:

Mr. B. C. Hanks, P. E.  
State Structures Engineer  
North Carolina Department  
of Transportation  
Structures Management Unit  
1000 Birch Ridge Drive  
Raleigh, NC 27610

Attention: Mr. J. L. Bolden, P.

Submittals may also be made via email.

Send submittals to:

[jlbolden@ncdot.gov](mailto:jlbolden@ncdot.gov) (James Bolden)

Send an additional e-copy of the submittal to the following address:

# ST-14

Project U-2579C

Forsyth County

[eomile@ncdot.gov](mailto:eomile@ncdot.gov) (Emmanuel Omile)

[mrorie@ncdot.gov](mailto:mrorie@ncdot.gov) (Madonna Rorie)

For submittals to the Geotechnical Engineering Unit, use the following addresses:

For projects in Divisions 1-7, use the following Eastern Regional Office address:

Via US mail:

Mr. Chris Kreider, P. E.  
Eastern Regional Geotechnical  
Manager  
North Carolina Department  
of Transportation  
Geotechnical Engineering Unit  
Eastern Regional Office  
1570 Mail Service Center  
100  
Raleigh, NC 27699-1570

Via other delivery service:

Mr. Chris Kreider, P. E.  
Eastern Regional Geotechnical  
Manager  
North Carolina Department  
of Transportation  
Geotechnical Engineering Unit  
Eastern Regional Office  
3301 Jones Sausage Road, Suite  
Garner, NC 27529

Via Email: [EastGeotechnicalSubmittal@ncdot.gov](mailto:EastGeotechnicalSubmittal@ncdot.gov)

For projects in Divisions 8-14, use the following Western Regional Office address:

Via US mail or other delivery service:

Mr. Eric Williams, P. E.  
Western Regional Geotechnical  
Manager  
North Carolina Department  
of Transportation  
Geotechnical Engineering Unit  
Western Regional Office  
5253 Z Max Boulevard  
Harrisburg, NC 28075

Via Email: [WestGeotechnicalSubmittal@ncdot.gov](mailto:WestGeotechnicalSubmittal@ncdot.gov)

The status of the review of structure-related submittals sent to the Structures Management Unit can be viewed from the Unit's website, via the "Drawing Submittal Status" link.

The status of the review of geotechnical-related submittals sent to the Geotechnical Engineering Unit can be viewed from the Unit's website, via the "Geotechnical Construction Submittals" link.

Direct any questions concerning submittal review status, review comments or drawing markups to the following contacts:

# ST-15

Project U-2579C

Forsyth County

Primary Structures Contact: James Bolden (919) 707 – 6408  
(919) 250 – 4082 facsimile  
[jlbolden@ncdot.gov](mailto:jlbolden@ncdot.gov)

Secondary Structures Contacts: Emmanuel Omile  
(919) 707 – 6451  
Madonna Rorie  
(919) 707 – 6508

Eastern Regional Geotechnical Contact (Divisions 1-7):  
Chris Kreider  
(919) 662 – 4710  
[ckreider@ncdot.gov](mailto:ckreider@ncdot.gov)

Western Regional Geotechnical Contact (Divisions 8-14):  
Eric Williams  
(704) 455 – 8902  
[ewilliams3@ncdot.gov](mailto:ewilliams3@ncdot.gov)

### 3.0 SUBMITTAL COPIES

Furnish one complete copy of each submittal, including all attachments, to the Engineer. At the same time, submit the number of hard copies shown below of the same complete submittal directly to the Structures Management Unit and/or the Geotechnical Engineering Unit.

The first table below covers “Structure Submittals”. The Engineer will receive review comments and drawing markups for these submittals from the Structures Management Unit. The second table in this section covers “Geotechnical Submittals”. The Engineer will receive review comments and drawing markups for these submittals from the Geotechnical Engineering Unit.

Unless otherwise required, submit one set of supporting calculations to either the Structures Management Unit or the Geotechnical Engineering Unit unless both units require submittal copies in which case submit a set of supporting calculations to each unit. Provide additional copies of any submittal as directed.



# ST-16

Project U-2579C

Forsyth County

## STRUCTURE SUBMITTALS

<b>Submittal</b>	<b>Copies Required by Structures Management Unit</b>	<b>Copies Required by Geotechnical Engineering Unit</b>	<b>Contract Reference Requiring Submittal <sup>1</sup></b>
Arch Culvert Falsework	5	0	Plan Note, SN Sheet & “Falsework and Formwork”
Box Culvert Falsework <sup>7</sup>	5	0	Plan Note, SN Sheet & “Falsework and Formwork”
Cofferdams	6	2	Article 410-4
Foam Joint Seals <sup>6</sup>	9	0	“Foam Joint Seals”
Expansion Joint Seals (hold down plate type with base angle)	9	0	“Expansion Joint Seals”
Expansion Joint Seals (modular)	2, then 9	0	“Modular Expansion Joint Seals”
Expansion Joint Seals (strip seals)	9	0	“Strip Seals”
Falsework & Forms <sup>2</sup> (substructure)	8	0	Article 420-3 & “Falsework and Formwork”
Falsework & Forms (superstructure)	8	0	Article 420-3 & “Falsework and Formwork”
Girder Erection over Railroad	5	0	Railroad Provisions
Maintenance and Protection of Traffic Beneath Proposed Structure	8	0	“Maintenance and Protection of Traffic Beneath Proposed Structure at Station ____”
Metal Bridge Railing	8	0	Plan Note
Metal Stay-in-Place Forms	8	0	Article 420-3
Metalwork for Elastomeric Bearings <sup>4,5</sup>	7	0	Article 1072-8

# ST-17

Project U-2579C

Forsyth County

Miscellaneous Metalwork <sup>4,5</sup>	7	0	Article 1072-8
Disc Bearings <sup>4</sup>	8	0	“Disc Bearings”
Overhead and Digital Message Signs (DMS) (metalwork and foundations)	13	0	Applicable Provisions
Placement of Equipment on Structures (cranes, etc.)	7	0	Article 420-20
Precast Concrete Box Culverts	2, then 1 reproducible	0	“Optional Precast Reinforced Concrete Box Culvert at Station ____”
Prestressed Concrete Cored Slab (detensioning sequences) <sup>3</sup>	6	0	Article 1078-11
Prestressed Concrete Deck Panels	6 and 1 reproducible	0	Article 420-3
Prestressed Concrete Girder (strand elongation and detensioning sequences)	6	0	Articles 1078-8 and 1078-11
Removal of Existing Structure over Railroad	5	0	Railroad Provisions
Revised Bridge Deck Plans (adaptation to prestressed deck panels)	2, then 1 reproducible	0	Article 420-3
Revised Bridge Deck Plans (adaptation to modular expansion joint seals)	2, then 1 reproducible	0	“Modular Expansion Joint Seals”
Sound Barrier Wall (precast items)	10	0	Article 1077-2 & “Sound Barrier Wall”
Sound Barrier Wall Steel Fabrication Plans <sup>5</sup>	7	0	Article 1072-8 & “Sound Barrier Wall”
Structural Steel <sup>4</sup>	2, then 7	0	Article 1072-8
Temporary Detour Structures	10	2	Article 400-3 & “Construction, Maintenance and Removal of Temporary Structure at Station ____”
TFE Expansion Bearings <sup>4</sup>	8	0	Article 1072-8

**FOOTNOTES**

1. References are provided to help locate the part of the contract where the submittals are required. References in quotes refer to the provision by that name. Articles refer to the *Standard Specifications*.
2. Submittals for these items are necessary only when required by a note on plans.
3. Submittals for these items may not be required. A list of pre-approved sequences is available from the producer or the Materials & Tests Unit.
4. The fabricator may submit these items directly to the Structures Management Unit.
5. The two sets of preliminary submittals required by Article 1072-8 of the *Standard Specifications* are not required for these items.
6. Submittals for Fabrication Drawings are not required. Submittals for Catalogue Cuts of Proposed Material are required. See Section 5.A of the referenced provision.
7. Submittals are necessary only when the top slab thickness is 18” or greater.

**GEOTECHNICAL SUBMITTALS**

Submittal	Copies Required by Geotechnical Engineering Unit	Copies Required by Structures Management Unit	Contract Reference Requiring Submittal <sup>1</sup>
Drilled Pier Construction Plans <sup>2</sup>	1	0	Subarticle 411-3(A)
Crosshole Sonic Logging (CSL) Reports <sup>2</sup>	1	0	Subarticle 411-5(A)(2)
Pile Driving Equipment Data Forms <sup>2,3</sup>	1	0	Subarticle 450-3(D)(2)
Pile Driving Analyzer (PDA) Reports <sup>2</sup>	1	0	Subarticle 450-3(F)(3)
Retaining Walls <sup>4</sup>	1 drawings, 1 calculations	2 drawings	Applicable Provisions
Temporary Shoring <sup>4</sup>	1 drawings, 1 calculations	2 drawings	“Temporary Shoring” & “Temporary Soil Nail Walls”

## FOOTNOTES

1. References are provided to help locate the part of the contract where the submittals are required. References in quotes refer to the provision by that name. Subarticles refer to the *Standard Specifications*.
2. Submit one hard copy of submittal to the Engineer. Submit a second copy of submittal electronically (PDF via email), US mail or other delivery service to the appropriate Geotechnical Engineering Unit regional office. Electronic submission is preferred.
3. The Pile Driving Equipment Data Form is available from:  
[https://connect.ncdot.gov/resources/Geological/Pages/Geotech\\_Forms\\_Details.aspx](https://connect.ncdot.gov/resources/Geological/Pages/Geotech_Forms_Details.aspx)  
See second page of form for submittal instructions.
4. Electronic copy of submittal is required. See referenced provision.

## CRANE SAFETY

(8-15-05)

Comply with the manufacturer specifications and limitations applicable to the operation of any and all cranes and derricks. Prime contractors, sub-contractors, and fully operated rental companies shall comply with the current Occupational Safety and Health Administration regulations (OSHA).

Submit all items listed below to the Engineer prior to beginning crane operations involving critical lifts. A critical lift is defined as any lift that exceeds 75 percent of the manufacturer's crane chart capacity for the radius at which the load will be lifted or requires the use of more than one crane. Changes in personnel or equipment must be reported to the Engineer and all applicable items listed below must be updated and submitted prior to continuing with crane operations.

### CRANE SAFETY SUBMITTAL LIST

- A. **Competent Person:** Provide the name and qualifications of the "Competent Person" responsible for crane safety and lifting operations. The named competent person will have the responsibility and authority to stop any work activity due to safety concerns.
- B. **Riggers:** Provide the qualifications and experience of the persons responsible for rigging operations. Qualifications and experience should include, but not be

limited to, weight calculations, center of gravity determinations, selection and inspection of sling and rigging equipment, and safe rigging practices.

- C. **Crane Inspections:** Inspection records for all cranes shall be current and readily accessible for review upon request.
- D. **Certifications:** **By July 1, 2006**, crane operators performing critical lifts shall be certified by NC CCO (National Commission for the Certification of Crane Operators), or satisfactorily complete the Carolinas AGC's Professional Crane Operator's Proficiency Program. Other approved nationally accredited programs will be considered upon request. All crane operators shall also have a current CDL medical card. Submit a list of anticipated critical lifts and corresponding crane operator(s). Include current certification for the type of crane operated (small hydraulic, large hydraulic, small lattice, large lattice) and medical evaluations for each operator.

## **GROUT FOR STRUCTURES**

**(9-30-11)**

### **1.0 DESCRIPTION**

This special provision addresses grout for use in pile blockouts, grout pockets, shear keys, dowel holes and recesses for structures. This provision does not apply to grout placed in post-tensioning ducts for bridge beams, girders, or decks. Mix and place grout in accordance with the manufacturer's recommendations, the applicable sections of the Standard Specifications and this provision.

### **2.0 MATERIAL REQUIREMENTS**

Use a Department approved pre-packaged, non-shrink, non-metallic grout. Contact the Materials and Tests Unit for a list of approved pre-packaged grouts and consult the manufacturer to determine if the pre-packaged grout selected is suitable for the required application.

When using an approved pre-packaged grout, a grout mix design submittal is not required.

The grout shall be free of soluble chlorides and contain less than one percent soluble sulfate. Supply water in compliance with Article 1024-4 of the Standard Specifications.

Aggregate may be added to the mix only where recommended or permitted by the manufacturer and Engineer. The quantity and gradation of the aggregate shall be in accordance with the manufacturer's recommendations.

Admixtures, if approved by the Department, shall be used in accordance with the manufacturer's recommendations. The manufacture date shall be clearly stamped on each container. Admixtures with an expired shelf life shall not be used.

The Engineer reserves the right to reject material based on unsatisfactory performance.

Initial setting time shall not be less than 10 minutes when tested in accordance with ASTM C266.

Test the expansion and shrinkage of the grout in accordance with ASTM C1090. The grout shall expand no more than 0.2% and shall exhibit no shrinkage. Furnish a Type 4 material certification showing results of tests conducted to determine the properties listed in the Standard Specifications and to assure the material is non-shrink.

Unless required elsewhere in the contract the compressive strength at 3 days shall be at least 5000 psi. Compressive strength in the laboratory shall be determined in accordance with ASTM C109 except the test mix shall contain only water and the dry manufactured material. Compressive strength in the field will be determined by molding and testing 4" x 8" cylinders in accordance with AASHTO T22. Construction loading and traffic loading shall not be allowed until the 3 day compressive strength is achieved.

When tested in accordance with ASTM C666, Procedure A, the durability factor of the grout shall not be less than 80.

### **3.0 SAMPLING AND PLACEMENT**

Place and maintain components in final position until grout placement is complete and accepted. Concrete surfaces to receive grout shall be free of defective concrete, laitance, oil, grease and other foreign matter. Saturate concrete surfaces with clean water and remove excess water prior to placing grout.

Do not place grout if the grout temperature is less than 50°F or more than 90°F or if the air temperature measured at the location of the grouting operation in the shade away from artificial heat is below 45°F.

Provide grout at a rate that permits proper handling, placing and finishing in accordance with the manufacturer's recommendations unless directed otherwise by the Engineer. Use grout free of any lumps and undispersed cement. Agitate grout continuously before placement.

Control grout delivery so the interval between placing batches in the same component does not exceed 20 minutes.

The Engineer will determine the locations to sample grout and the number and type of samples collected for field and laboratory testing. The compressive strength of the grout will be considered the average compressive strength test results of 3 cube or 2 cylinder specimens at 28 days.

## 4.0 BASIS OF PAYMENT

No separate payment will be made for "Grout for Structures". The cost of the material, equipment, labor, placement, and any incidentals necessary to complete the work shall be considered incidental to the structure item requiring grout.

### **EMBEDDED CLIPS FOR PRESTRESSED CONCRETE GIRDERS** (6-22-16)

The 2012 Standard Specifications shall be revised as follows:

Replace Section **420-3(D) – Forms for Concrete Bridge Decks**, Subsection **(2) – Fabricated Metal Stay-In-Place Forms**, criterion **(j)** with the following:

Weld metal stay-in-place forms for prestressed concrete girders to embedded clips in the girder flanges. The embedded clips shall be at least 2" x 3" and 2" long. The clips shall be galvanized, 10-gauge ASTM A653 steel and have a 3/4" or 1" diameter hole in the 2" leg. The spacing of the clips shall be 12". All submitted metal stay-in-place form designs shall be able to use the standard size and spacing of the clip described above.

**PROJECT SPECIAL PROVISION**

(10-18-95) (Rev. 3-21-17)

Z-1

**PERMITS**

The Contractor's attention is directed to the following permits, which have been issued to the Department of Transportation by the authority granting the permit.

<b><u>PERMIT</u></b>	<b><u>AUTHORITY GRANTING THE PERMIT</u></b>
Dredge and Fill and/or Work in Navigable Waters (404)	U. S. Army Corps of Engineers
Water Quality (401)	Division of Environmental Management, DEQ State of North Carolina

The Contractor shall comply with all applicable permit conditions during construction of this project. Those conditions marked by \* are the responsibility of the Department and the Contractor has no responsibility in accomplishing those conditions.

Agents of the permitting authority will periodically inspect the project for adherence to the permits.

The Contractor's attention is also directed to Articles 107-10 and 107-13 of the *2012 Standard Specifications* and the following:

Should the Contractor propose to utilize construction methods (such as temporary structures or fill in waters and/or wetlands for haul roads, work platforms, cofferdams, etc.) not specifically identified in the permit (individual, general, or nationwide) authorizing the project it shall be the Contractor's responsibility to coordinate with the Engineer to determine what, if any, additional permit action is required. The Contractor shall also be responsible for initiating the request for the authorization of such construction method by the permitting agency. The request shall be submitted through the Engineer. The Contractor shall not utilize the construction method until it is approved by the permitting agency. The request normally takes approximately 60 days to process; however, no extensions of time or additional compensation will be granted for delays resulting from the Contractor's request for approval of construction methods not specifically identified in the permit.

**Where construction moratoriums are contained in a permit condition which restricts the Contractor's activities to certain times of the year, those moratoriums will apply only to the portions of the work taking place in the restricted waters, wetlands or buffer zones, provided that activities outside those areas is done in such a manner as to not affect the restricted waters, wetlands or buffer zones.**

DocuSigned by:  
  
 68A7405FFA5F48E...





**P-2**

**DEPARTMENT OF THE ARMY**  
WILMINGTON DISTRICT, CORPS OF ENGINEERS  
69 DARLINGTON AVENUE  
WILMINGTON, NORTH CAROLINA 28403-1343

August 17, 2017

Regulatory Division

Action ID: SAW-2017-01232

Mr. Philip S. Harris III, P.E., C.P.M.  
Natural Environment Section Head  
North Carolina Department of Transportation  
Division of Highways  
1598 Mail Service Center  
Raleigh, North Carolina 27699-1598

Dear Mr. Harris:

In accordance with the written request of August 17, 2017, and the ensuing administrative record, enclosed is a Department of the Army (DA) Permit to authorize the construct of a 1.99 mile long portion of new location roadway known as the Winston-Salem Northern Beltway between US 158 and US-311 in Forsyth County, TIP U-2579C. The project involves the permanent discharge of dredged or fill material into 977 linear feet of stream channel (921 linear feet of permanent loss and 76 linear feet of bank stabilization), 0.88 acre of riparian wetlands (0.79 acre of permanent fill, and 0.09 acre of mechanized clearing), as well as the temporary discharge of dredged or fill material into 199 linear feet of stream channel.

Any deviation in the authorized work will likely require modification of this permit. If a change in the authorized work is necessary, you should promptly submit revised plans to the Corps showing the proposed changes. You may not undertake the proposed changes until the Corps notified you that your permit has been modified.

Carefully read your permit. The general and special conditions are important. Your failure to comply with these conditions could result in a violation of Federal law. Certain significant general conditions require that:

- a. You must complete construction before **December 31, 2022**.
- b. You must notify this office in advance as to when you intend to commence and complete work.
- c. You must allow representatives from this office to make periodic visits to your worksite as deemed necessary to assure compliance with permit plans and conditions.

You should address all questions regarding this authorization to Mr. James Lastinger in the Raleigh Regulatory Field Office, telephone number (919) 554-4884, extension 32.

Thank you in advance for completing our Customer Survey Form. This can be accomplished by visiting our web-site at [http://corpsmapu.usace.army.mil/cm\\_apex/f?p=136:4:0](http://corpsmapu.usace.army.mil/cm_apex/f?p=136:4:0) and completing the survey on-line. We value your comments and appreciate your taking the time to complete a survey each time you interact with our office.

Sincerely,

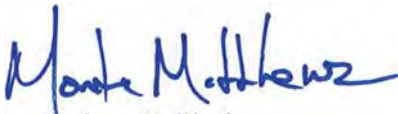
  
for/ Robert J. Clark  
Colonel, U.S. Army  
District Commander

Enclosures

Copy Furnished: (with enclosures):

Chief, Source Data Unit  
NOAA/National Ocean Service  
Attn: Sharon Tear N/CS261  
1315 East-West Hwy., Rm 7316  
Silver Spring, Maryland 20910-3282

Copies Furnished: (with special conditions and plans):

Mr. Pete Benjamin  
U.S. Fish and Wildlife Service  
Raleigh Ecological Service Field Office  
Post Office Box 33726  
Raleigh, North Carolina 27636-3726

Mr. Kenneth Riley, Ph.D.  
Habitat Conservation Division  
National Marine Fisheries Service Southeast Region  
101 Pivers Island Road  
Beaufort, North Carolina 28516

Mr. Todd Bowers  
Oceans, Wetlands and Streams Protection Branch  
Wetlands and Streams Regulatory Section  
U.S. Environmental Protection Agency – Region 4  
Sam Nunn Atlanta Federal Center  
61 Forsyth Street, SW  
Atlanta, Georgia 30303-8931

Mr. Doug Huggett  
Division Coastal Management  
N.C. Department of Environment  
And Natural Resources  
400Commerce Avenue  
Morehead City, North Carolina 28557

Dr. Pace Wilber  
Habitat Conservation Division – Atlantic Branch  
NOAA Fisheries Service  
219 Fort Johnston Road  
Charleston, South Carolina 29412

**DEPARTMENT OF THE ARMY PERMIT**

Permittee **NORTH CAROLINA DEPARTMENT OF TRANSPORTATION**  
**ATTN: MR. PHILIP S. HARRIS III, P.E., C.P.M.**

Permit No. **SAW-2017-01232**

Issuing Office **CESAW-RG-R**

NOTE: The term "you" and its derivatives, as used in this permit, means the permittee or any future transferee. The term "this office" refers to the appropriate district or division office of the Corps of Engineers having jurisdiction over the permitted activity or the appropriate official of that office acting under the authority of the commanding officer.

You are authorized to perform work in accordance with the terms and conditions specified below.

**Project Description: The project involves construction of 1.99 mile long portion of new location roadway known as the Winston-Salem Northern Beltway between US 158 and US-311 in Forsyth County, TIP U-2579C. The project involves the permanent discharge of dredged or fill material into 977 linear feet of stream channel (921 linear feet of permanent loss and 76 linear feet of bank stabilization), 0.88 acre of riparian wetlands (0.79 acre of permanent fill, and 0.09 acre of mechanized clearing), as well as the temporary discharge of dredged or fill material into 199 linear feet of stream channel.**

**Project Location: The project area is a new alignment linear transportation corridor from US 158 running northwest to a new interchange with US-311 located east of Winston-Salem, Forsyth County, North Carolina. (36.15003°N, -80.1695°W [central point]).**

Permit Conditions:

General Conditions:

1. The time limit for completing the work authorized ends on **December 31, 2022.** If you find that you need more time to complete the authorized activity, submit your request for a time extension to this office for consideration at least one month before the above date is reached.
2. You must maintain the activity authorized by this permit in good condition and in conformance with the terms and conditions of this permit. You are not relieved of this requirement if you abandon the permitted activity, although you may make a good faith transfer to a third party in compliance with General Condition 4 below. Should you wish to cease to maintain the authorized activity or should you desire to abandon it without a good faith transfer, you must obtain a modification of this permit from this office, which may require restoration of the area.
3. If you discover any previously unknown historic or archeological remains while accomplishing the activity authorized by this permit, you must immediately notify this office of what you have found. We will initiate the Federal and state coordination required to determine if the remains warrant a recovery effort or if the site is eligible for listing in the National Register of Historic Places.
4. If you sell the property associated with this permit, you must obtain the signature of the new owner in the space provided and forward a copy of the permit to this office to validate the transfer of this authorization.
5. If a conditioned water quality certification has been issued for your project, you must comply with the conditions specified in the certification as special conditions to this permit. For your convenience, a copy of the certification is attached if it contains such conditions.

6. You must allow representatives from this office to inspect the authorized activity at any time deemed necessary to ensure that it is being or has been accomplished in accordance with the terms and conditions of your permit,

Special Conditions:

**SEE ATTACHED SPECIAL CONDITIONS**

Further Information:

1. Congressional Authorities: You have been authorized to undertake the activity described above pursuant to:
  - ( ) Section 10 of the Rivers and Harbors Act of 1899 (33 U.S.C. 403).
  - ( X ) Section 404 of the Clean Water Act (33 U.S.C. 1344).
  - ( ) Section 103 of the Marine Protection, Research and Sanctuaries Act of 1972 (33 U.S.C. 1413).
2. Limits of this authorization.
  - a. This permit does not obviate the need to obtain other Federal, state, or local authorizations required by law.
  - b. This permit does not grant any property rights or exclusive privileges.
  - c. This permit does not authorize any injury to the property or rights of others.
  - d. This permit does not authorize interference with any existing or proposed Federal project.
3. Limits of Federal Liability. In issuing this permit, the Federal Government does not assume any liability for the following:
  - a. Damages to the permitted project or uses thereof as a result of other permitted or unpermitted activities or from natural causes.
  - b. Damages to the permitted project or uses thereof as a result of current or future activities undertaken by or on behalf of the United States in the public interest.
  - c. Damages to persons, property, or to other permitted or unpermitted activities or structures caused by the activity authorized by this permit.
  - d. Design or construction deficiencies associated with the permitted work.
  - e. Damage claims associated with any future modification, suspension, or revocation of this permit.
4. Reliance on Applicant's Data: The determination of this office that issuance of this permit is not contrary to the public interest was made in reliance on the information you provided.
5. Reevaluation of Permit Decision. This office may reevaluate its decision on this permit at any time the circumstances warrant. Circumstances that could require a reevaluation include, but are not limited to, the following:
  - a. You fail to comply with the terms and conditions of this permit.
  - b. The information provided by you in support of your permit application proves to have been false, incomplete, or inaccurate (See 4 above).

**P-7**

c. Significant new information surfaces which this office did not consider in reaching the original public interest decision.

Such a reevaluation may result in a determination that it is appropriate to use the suspension, modification, and revocation procedures contained in 33 CFR 325.7 or enforcement procedures such as those contained in 33 CFR 326.4 and 326.5. The referenced enforcement procedures provide for the issuance of an administrative order requiring you to comply with the terms and conditions of your permit and for the initiation of legal action where appropriate. You will be required to pay for any corrective measures ordered by this office, and if you fail to comply with such directive, this office may in certain situations (such as those specified in 33 CFR 209.170) accomplish the corrective measures by contract or otherwise and bill you for the cost.

6. Extensions. General condition I establishes a time limit for the completion of the activity authorized by this permit, Unless there are circumstances requiring either a prompt completion of the authorized activity or a reevaluation of the public interest decision, the Corps will normally give favorable consideration to a request for an extension of this time limit.

Your signature below, as permittee, indicates that you accept and agree to comply with the terms and conditions of this permit.

  
\_\_\_\_\_  
(PERMITTEE) NORTH CAROLINA DEPARTMENT OF TRANSPORTATION  
for ATTN: MR. PHILIP S. HARRIS III, P.E., C.P.M. 08-17-2017  
\_\_\_\_\_  
(DATE)

This permit becomes effective when the Federal official, designated to act for the Secretary of the Army, has signed below.

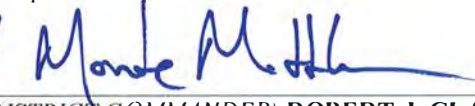
for   
\_\_\_\_\_  
(DISTRICT COMMANDER) ROBERT J. CLARK, COLONEL 17 Aug 2017  
\_\_\_\_\_  
(DATE)

When the structures or work authorized by this permit are still in existence at the time the property is transferred, the terms and conditions of this permit will continue to be binding on the new owner(s) of the property. To validate the transfer of this permit and the associated liabilities associated with compliance with its terms and conditions, have the transferee sign and date below.

\_\_\_\_\_  
(TRANSFEREE) \_\_\_\_\_  
(DATE)



**SPECIAL CONDITIONS  
ACTION ID: SAW-2017-01232  
NORTH CAROLINA DEPARTMENT OF TRANSPORTATION  
I-74 WINSTON-SALEM NORTHERN BELTWAY TIP NO. U-2579C**

**WORK LIMITS**

1. **CONSTRUCTION PLANS:** All work authorized by this permit must be performed in strict compliance with the attached plans for U-2579C, Wetland Surface Water Impacts Permit, dated June 13, 2017, Any modification to these plans must be approved by the US Army Corps of Engineers (USACE) prior to implementation.
2. **UNAUTHORIZED DREDGE OR FILL:** Except as authorized by this permit or any USACE approved modification to this permit, no excavation, fill or mechanized land-clearing activities shall take place at any time in the construction or maintenance of this project, within waters or wetlands. This permit does not authorize temporary placement or double handling of excavated or fill material within waters or wetlands outside the permitted area. This prohibition applies to all borrow and fill activities connected with this project.
3. **MAINTAIN CIRCULATION AND FLOW OF WATERS:** Except as specified in the plans attached to this permit, no excavation, fill or mechanized land-clearing activities shall take place at any time in the construction or maintenance of this project, in such a manner as to impair normal flows and circulation patterns within waters or wetlands or to reduce the reach of waters or wetlands.
4. **DEVIATION FROM PERMITTED PLANS:** The permittee shall ensure that the construction design plans for this project do not deviate from the permit plans attached to this authorization. Written verification shall be provided that the final construction drawings comply with the attached permit drawings prior to any active construction in waters of the United States, including wetlands. Any deviation in the construction design plans will be brought to the attention of the Corps of Engineers, Mr. James Lastinger of the Raleigh Regulatory Field Office prior to any active construction in waters or wetlands.
5. **PRECONSTRUCTION MEETING:** The Permittee shall schedule an onsite preconstruction meeting between its representatives, the contractor's representatives and the appropriate Corps of Engineers Project Manager prior to undertaking any work within jurisdictional waters and wetlands to ensure that there is a mutual understanding of all terms and conditions contained within the Department of the Army permit. The Permittee shall notify the Corps of Engineers Project Manager a minimum of thirty (30) days in advance of the scheduled meeting in order to provide that individual with ample opportunity to schedule and participate in the required meeting.
6. **BORROW AND WASTE:** To ensure that all borrow and waste activities occur on high ground and do not result in the degradation of adjacent wetlands and streams, except as authorized by this permit, the permittee shall require its contractors and/or agents to identify all areas to be used to borrow material, or to dispose of dredged, fill, or waste material. The permittee shall provide the USACE with appropriate maps indicating the

**SPECIAL CONDITIONS  
ACTION ID: SAW-2017-01232  
NORTH CAROLINA DEPARTMENT OF TRANSPORTATION  
I-74 WINSTON-SALEM NORTHERN BELTWAY TIP NO. U-2579C**

locations of proposed borrow or waste sites as soon as the permittee has that information. The permittee will coordinate with the USACE before approving any borrow or waste sites that are within 400 feet of any streams or wetlands.

**RELATED LAWS**

7. **WATER CONTAMINATION:** All mechanized equipment will be regularly inspected and maintained to prevent contamination of waters and wetlands from fuels, lubricants, hydraulic fluids, or other toxic materials. In the event of a spill of petroleum products or any other hazardous waste, the permittee shall immediately report it to the N.C. Division of Water Quality at (919) 733-3300 or (800) 858-0368 and provisions of the North Carolina Oil Pollution and Hazardous Substances Control Act will be followed.

8. The North Carolina Division of Environmental Quality (DEQ) permit/certification number 4123 was issued for this project on July 26, 2017. Special conditions were issued associated with this water quality permit/certification and a copy of these conditions is attached as Exhibit A. These referenced conditions are hereby incorporated as special conditions of this permit.

**PROJECT MAINTENANCE**

\*9. **NOTIFICATION OF CONSTRUCTION COMMENCEMENT AND COMPLETION:** The permittee shall advise the Corps in writing prior to beginning the work authorized by this permit and again upon completion of the work authorized by this permit.

10. **PERMIT DISTRIBUTION:** The permittee shall require its contractors and/or agents to comply with the terms and conditions of this permit in the construction and maintenance of this project, and shall provide each of its contractors and/or agents associated with the construction or maintenance of this project with a copy of this permit. A copy of this permit, including all conditions, shall be available at the project site during construction and maintenance of this project.

11. **PERMIT REVOCATION:** The permittee, upon receipt of a notice of revocation of this permit or upon its expiration before completion of the work will, without expense to the United States and in such time and manner as the Secretary of the Army or his authorized representative may direct, restore the water or wetland to its pre-project condition.

12. **CLEAN FILL:** Unless otherwise authorized by this permit, all fill material placed in waters or wetlands shall be generated from an upland source and will be clean and free of any pollutants except in trace quantities. Metal products, organic materials (including debris from land clearing activities), or unsightly debris will not be used. Soils used for fill shall not be contaminated with any toxic substance in concentrations governed by Section 307 of the Clean Water Act.



**SPECIAL CONDITIONS  
ACTION ID: SAW-2017-01232  
NORTH CAROLINA DEPARTMENT OF TRANSPORTATION  
I-74 WINSTON-SALEM NORTHERN BELTWAY TIP NO. U-2579C**

13. SILT-FENCING: The permittee shall employ all sedimentation and erosion control measures necessary to prevent an increase in sedimentation or turbidity within waters and wetlands outside the permit area. This shall include, but is not limited to, the immediate installation of silt fencing or similar appropriate devices around all areas subject to soil disturbance or the movement of earthen fill, and the immediate stabilization of all disturbed areas. Additionally, the project must remain in full compliance with all aspects of the Sedimentation Pollution Control Act of 1973 (North Carolina General Statutes Chapter 113A Article 4). Fescue will not be planted within wetland areas.

14. EROSION CONTROL MEASURES IN JURISDICTIONAL WATERS:

A. During the clearing phase of the project, heavy equipment must not be operated in surface waters or stream channels. Temporary stream crossings will be used to access the opposite sides of stream channels. All temporary diversion channels and stream crossings will be constructed of non-erodible materials. Grubbing of riparian vegetation will not occur until immediately before construction begins on a given segment of stream channel.

B. No fill or excavation impacts for the purposes of sedimentation and erosion control shall occur within jurisdictional waters, including wetlands, unless the impacts are included on the plan drawings and specifically authorized by this permit.

C. The permittee shall remove all sediment and erosion control measures placed in wetlands or waters, and shall restore natural grades in those areas, prior to project completion.

15. PROHIBITION ON CONCRETE: The permittee shall take measures to prevent live or fresh concrete, including bags of uncured concrete, from coming into contact with any water in or entering into waters of the United States. Water inside coffer dams or casings that has been in contact with concrete shall only be returned to waters of the United States when it no longer poses a threat to aquatic organisms (i.e. concrete is set and cured).

16. INSTALLATION OF CULVERTS: Unless otherwise requested in the applicant's application and depicted on the approved work plans, culverts greater than 48 inches in diameter will be buried at least one foot below the bed of the stream. Culverts 48 inches in diameter and less shall be buried or placed on the stream bed as practicable and appropriate to maintain aquatic passage, and every effort shall be made to maintain existing channel slope. The bottom of the culvert must be placed at a depth below the natural stream bottom to provide for passage during drought or low flow conditions. Destabilizing the channel

# P-11

**SPECIAL CONDITIONS**  
**ACTION ID: SAW-2017-01232**  
**NORTH CAROLINA DEPARTMENT OF TRANSPORTATION**  
**I-74 WINSTON-SALEM NORTHERN BELTWAY TIP NO. U-2579C**

and head cutting upstream should be considered in the placement of the culvert. The following pipes are exempt from this condition:

- site 6: 24-inch Reinforced Concrete Pipe (RCP) outlet at station 31 + 30-Y1-Rt
- site 7: 72-inch RCP inlet at station 413+74-L-Lt
- site 9: 78-inch CSP inlet at station 21+46-Y1RPD-Rt; 78-inch CSP at station 25+82-Y1RPD-Lt
- site 14: 42-inch RCP outlet at station 42+15-Y1-Rt

17. **AQUATIC PASSAGE:** Measures will be included in the construction/installation that will promote the safe passage of fish and other aquatic organisms. The dimension, pattern, and profile of the stream above and below a pipe or culvert should not be modified by widening the stream channel or by reducing the depth of the stream in connection with the construction activity. The width, height, and gradient of a proposed opening should be such as to pass the average historical low flow and spring flow without adversely altering flow velocity. Spring flow should be determined from gauge data, if available. In the absence of such data, bankfull flow can be used as a comparable level.

## ESA

18. **THREATENED AND ENDANGERED SPECIES:** All necessary precautions and measures will be implemented so that any activity will not kill, injure, capture, harass, or otherwise harm any protected federally listed species. While accomplishing the authorized work, if the permittee discovers or observes a damaged or hurt listed endangered or threatened species, the District Engineer will be immediately notified to initiate the required Federal coordination.

## SECTION 103

19. **UNKNOWN CULTURAL RESOURCES:** While accomplishing the authorized work, if the permittee discovers any previously unknown cultural resources, the District Engineer will be immediately notified so that required coordination can be initiated with the North Carolina Division of Cultural Resources.

## ENFORCEMENT

20. **REPORTING ADDRESS:** All reports, documentation and correspondence required by the conditions of this permit shall be submitted to the following address: U.S. Army Corps of Engineers, Regulatory Division, Raleigh Regulatory Field Office, c/o Mr. James Lastinger, 3331 Heritage Trade Drive, Suite 105, Wake Forest, North Carolina 27587, and by telephone at: 919-554-4884, extension 32. The Permittee shall reference the following permit number, SAW-2017-01232, on all submittals.

**SPECIAL CONDITIONS  
ACTION ID: SAW-2017-01232  
NORTH CAROLINA DEPARTMENT OF TRANSPORTATION  
I-74 WINSTON-SALEM NORTHERN BELTWAY TIP NO. U-2579C**

21. REPORTING VIOLATIONS OF THE CLEAN WATER ACT AND RIVERS AND HARBORS ACT: Violation of these conditions or violation of Section 404 of the Clean Water Act or Section 10 of the Rivers and Harbors Act must be reported in writing to the Wilmington District U.S. Army Corps of Engineers within 24 hours of the permittee's discovery of the violation.

22. COMPLIANCE INSPECTION: A representative of the Corps of Engineers will periodically and randomly inspect the work for compliance with these conditions. Deviations from these procedures may result in an administrative financial penalty and/or directive to cease work until the problem is resolved to the satisfaction of the Corps.

**COMPENSATORY MITIGATION**

\* 23. In order to compensate for impacts associated with this permit, mitigation shall be provided in accordance with the provisions outlined on the most recent version of the attached Compensatory Mitigation Responsibility Transfer Form. The requirements of this form, including any special conditions listed on this form, are hereby incorporated as special conditions of this permit authorization. (See Exhibit B)



ROY COOPER  
*Governor*

MICHAEL S. REGAN  
*Secretary*

S. JAY ZIMMERMAN  
*Director*

July 26, 2017

Mr. Philip S. Harris, III, P.E., CPM  
Natural Environment Section Head  
Project Development and Environmental Analysis  
North Carolina Department of Transportation  
1598 Mail Service Center  
Raleigh, North Carolina, 27699-1598

Subject: 401 Water Quality Certification Pursuant to Section 401 of the Federal Clean Water with ADDITIONAL CONDITIONS for proposed Winston Salem North Beltway (Eastern Section) from US 311 to US 158 in Forsyth County; Federal Aid Project No. NHP-0918(93); TIP No. U-2579C; WBS 4839.1.9. NCDWR Project No. 20170730.

Dear Mr. Harris:

Attached hereto is a copy of Certification No. WQC004123 issued to The North Carolina Department of Transportation (NCDOT) dated July 26, 2017.

If we can be of further assistance, do not hesitate to contact us.

Sincerely,

A handwritten signature in blue ink, appearing to read 'S. Jay Zimmerman'.

S. Jay Zimmerman, Director  
Division of Water Resources

Attachments

Electronic copy only distribution:

James Lastinger, US Army Corps of Engineers, Raleigh Field Office  
Amy Euliss, Division 9 Environmental Officer  
Rodger Rochelle, NC Department of Transportation  
Carla Dagnino, NC Department of Transportation  
Chris Militscher, US Environmental Protection Agency  
Marella Buncick, US Fish and Wildlife Service  
Marla Chambers, NC Wildlife Resources Commission  
Beth Harmon, Division of Mitigation Services  
File Copy

# P-14

## 401 Water Quality Certification Pursuant to Section 401 of the Federal Clean Water Act with ADDITIONAL CONDITIONS

**THIS CERTIFICATION** is issued in conformity with the requirements of Section 401 Public Laws 92-500 and 95-217 of the United States and subject to the North Carolina Division of Water Resources (NCDWR) Regulations in 15 NCAC 2H .0500. This certification authorizes the NCDOT to impact 0.88 acres of jurisdictional wetlands and 1,196 linear feet of jurisdictional streams in Forsyth County. The project shall be constructed pursuant to the application dated received June 8, 2017. The authorized impacts are as described below:

**Stream Impacts in the Yadkin Pee Dee River Basin**

Site	Permanent Fill in Intermittent Stream (linear ft)	Permanent Fill in Perennial Stream (linear ft)			Temporary Fill in Perennial Stream (linear ft)	Total Stream Impact (linear ft)	Stream Impacts Requiring Mitigation (linear ft)
		Culvert	Channel Stabilization	Bank Stabilization			
6	68	-	-	-	-	68	-
7A	-	205	-	25	40	270	205
9	-	271	45	-	56	372	316
11	-	317	-	25	23	365	317
12	-	-	-	26	80	106	-
14	-	15	-	-	-	15	-
<b>Total</b>	<b>68</b>	<b>808</b>	<b>45</b>	<b>76</b>	<b>199</b>	<b>1,196</b>	<b>838</b>

**Total Stream Impact for Project: 1,196 linear feet**

**Wetland Impacts in the Yadkin Pee Dee River Basin (riverine)**

Site	Fill (ac)	Mechanized Clearing (ac)	Hand Clearing (ac)	Total Wetland Impact (ac)
7	<0.01	<0.01	-	<0.01
7A	0.14	-	-	0.14
11	0.08	0.03	-	0.11
13	0.57	0.05	-	0.65
<b>Total</b>	<b>0.79</b>	<b>0.09</b>	<b>-</b>	<b>0.88</b>

**Total Wetland Impact for Project: 0.88 acres.**

The application provides adequate assurance that the discharge of fill material into the waters of the Yadkin Pee Dee River Basin in conjunction with the proposed development will not result in a violation of applicable Water Quality Standards and discharge guidelines. Therefore, the State of North Carolina certifies that this activity will not violate the applicable portions of Sections 301, 302, 303, 306, 307 of PL 92-500 and PL 95-217 if conducted in accordance with the application and conditions hereinafter set forth.

This approval is only valid for the purpose and design that you submitted in your application dated June 8, 2017. Should your project change, you are required to notify the NCDWR and submit a new application. If the property is sold, the new owner must be given a copy of this Certification and approval letter, and is thereby responsible for complying with all the conditions. If any additional wetland impacts, or stream impacts, for this project (now or in the future) exceed one acre or 300 linear feet, respectively, additional compensatory mitigation may be required as described in 15A NCAC 2H .0506 (h) (6) and (7). For this approval to remain valid, you are required to comply with all the conditions listed below. In addition, you should obtain all other federal, state or local permits before proceeding with your project including (but not limited to) Sediment and Erosion control, Coastal Stormwater, Non-discharge and Water Supply watershed regulations. This Certification shall expire on the same day as the expiration date of the corresponding Corps of Engineers Permit.

## Condition(s) of Certification:

### *Stream Mitigation*

- \*1. Compensatory mitigation for 838 linear feet of impact to streams is required. We understand that you have chosen to perform compensatory mitigation for impacts to streams through the North Carolina Division of Mitigation Service (DMS) (formerly NCEEP), and that the DMS has agreed to implement the mitigation for the project. The DMS has indicated in a letter dated June 2, 2017 that they will assume responsibility for satisfying the federal Clean Water Act compensatory mitigation requirements for the above-referenced project, in accordance with the DMS Mitigation Banking Instrument signed July 28, 2010.
2. Culverts, pipes and channel work shall be installed and constructed as described in the permit application. NCDWR shall be notified if culverts, pipes and channel work cannot be installed and constructed as described in the permit application. Culverts shall be designed to mimic natural stream cross section as closely as possible including flood plain elevations and/or sills and baffles where appropriate. Widening the stream channel should be avoided. [15A NCAC 02H.0506(b)(2)]
3. Riprap shall not be placed in the active thalweg channel or placed in the streambed in a manner that precludes aquatic life passage. Bioengineering boulders or structures should be properly designed, sized and installed as described in the permit application. [15A NCAC 02H.0506(b)(2)]
4. The stream channel shall be excavated no deeper than the natural bed material of the stream, to the maximum extent practicable. Efforts must be made to minimize impacts to the stream banks, as well as to vegetation responsible for maintaining the stream bank stability. [15A NCAC 02H.0506(b)(2)]
5. The post-construction removal of any temporary bridge structures must return the project site to its preconstruction contours and elevations. The impacted areas shall be revegetated with appropriate native species. [15A NCAC 02H .0506(b)(2)]
6. Bridge deck drains shall not discharge directly into the stream. Stormwater shall be directed across the bridge and pre-treated through site-appropriate means (grassed swales, pre-formed scour holes, vegetated buffers, etc.) as described in the permit application, before entering the stream. [15A NCAC 02H .0507(d)(2) and 15A NCAC 02H .0506(b)(5)]

## General Conditions

1. If concrete is used during construction, a dry work area shall be maintained to prevent direct contact between curing concrete and stream water. Water that inadvertently contacts uncured concrete shall not be discharged to surface waters due to the potential for elevated pH and possible aquatic life and fish kills. [15A NCAC 02B.0200]



## P-16

2. During the construction of the project, no staging of equipment of any kind is permitted in waters of the U.S., or protected riparian buffers. [15A NCAC 02H.0506(b)(2)]
3. The dimension, pattern and profile of the stream above and below the crossing shall not be modified. Disturbed floodplains and streams shall be restored to natural geomorphic conditions. [15A NCAC 02H.0506(b)(2)]
4. The use of rip-rap above the Normal High Water Mark shall be minimized. Any rip-rap placed for stream stabilization shall be placed in stream channels in such a manner that it does not impede aquatic life passage. [15A NCAC 02H.0506(b)(2)]
- \* 5. The Permittee shall ensure that the final design drawings adhere to the permit and to the permit drawings submitted for approval. [15A NCAC 02H .0507(c) and 15A NCAC 02H .0506 (b)(2) and (c)(2)]
6. All work in or adjacent to stream waters shall be conducted in a dry work area. Approved BMP measures from the most current version of NCDOT Construction and Maintenance Activities manual such as sandbags, rock berms, cofferdams and other diversion structures shall be used to prevent excavation in flowing water. [15A NCAC 02H.0506(b)(3) and (c)(3)]
7. Heavy equipment shall be operated from the banks rather than in the stream channel in order to minimize sedimentation and reduce the introduction of other pollutants into the stream. [15A NCAC 02H.0506(b)(3)]
8. All mechanized equipment operated near surface waters must be regularly inspected and maintained to prevent contamination of stream waters from fuels, lubricants, hydraulic fluids, or other toxic materials. [15A NCAC 02H.0506(b)(3)]
9. No rock, sand or other materials shall be dredged from the stream channel except where authorized by this certification. [15A NCAC 02H.0506(b)(3)]
10. Discharging hydroseed mixtures and washing out hydroseeders and other equipment in or adjacent to surface waters is prohibited. [15A NCAC 02H.0506(b)(3)]
11. The permittee and its authorized agents shall conduct its activities in a manner consistent with State water quality standards (including any requirements resulting from compliance with §303(d) of the Clean Water Act) and any other appropriate requirements of State and Federal law. If the NCDWR determines that such standards or laws are not being met (including the failure to sustain a designated or achieved use) or that State or federal law is being violated, or that further conditions are necessary to assure compliance, the NCDWR may reevaluate and modify this certification. [15A NCAC 02B.0200]
12. All fill slopes located in jurisdictional wetlands shall be placed at slopes no flatter than 3:1, unless otherwise authorized by this certification. [15A NCAC 02H.0506(b)(2)]
13. A copy of this Water Quality Certification shall be maintained on the construction site at all times. In addition, the Water Quality Certification and all subsequent modifications, if any, shall be maintained with the Division Engineer and the on-site project manager. [15A NCAC 02H .0507(c) and 15A NCAC 02H .0506 (b)(2) and (c)(2)]
14. The outside buffer, wetland or water boundary located within the construction corridor approved by this authorization shall be clearly marked by highly visible fencing or flagging prior to any land disturbing activities. Impacts to areas within the fencing are prohibited unless otherwise authorized by this certification. [15A NCAC 02H.0501 and .0502]
15. The issuance of this certification does not exempt the Permittee from complying with any and all statutes, rules, regulations, or ordinances that may be imposed by other government agencies (i.e. local, state, and federal) having jurisdiction, including but not limited to applicable buffer rules, stormwater management rules, soil erosion and sedimentation control requirements, etc.
16. The Permittee shall report any violations of this certification to the Division of Water Resources within 24 hours of discovery. [15A NCAC 02B.0506(b)(2)]

## P-17

- \* 17. Upon completion of the project (including any impacts at associated borrow or waste sites), the NCDOT Division Engineer (or appointee) shall complete and return the enclosed "Certification of Completion Form" to notify the NCDWR when all work included in the 401 Certification has been completed. [15A NCAC 02H.0502(f)]
18. Native riparian vegetation must be reestablished in the riparian areas within the construction limits of the project by the end of the growing season following completion of construction. [15A NCAC 02B.0506(3)]
19. There shall be no excavation from, or waste disposal into, jurisdictional wetlands or waters associated with this permit without appropriate modification. Should waste or borrow sites, or access roads to waste or borrow sites, be located in wetlands or streams, compensatory mitigation will be required since that is a direct impact from road construction activities. [15A NCAC 02H.0506(b)(3) and (c)(3)]
20. Erosion and sediment control practices must be in full compliance with all specifications governing the proper design, installation and operation and maintenance of such Best Management Practices in order to protect surface waters standards [15A NCAC 02H.0506(b)(3) and (c)(3)]:
- The erosion and sediment control measures for the project must be designed, installed, operated, and maintained in accordance with the most recent version of the *North Carolina Sediment and Erosion Control Planning and Design Manual*.
  - The design, installation, operation, and maintenance of the sediment and erosion control measures must be such that they equal, or exceed, the requirements specified in the most recent version of the *North Carolina Sediment and Erosion Control Manual*. The devices shall be maintained on all construction sites, borrow sites, and waste pile (spoil) projects, including contractor-owned or leased borrow pits associated with the project.
  - For borrow pit sites, the erosion and sediment control measures must be designed, installed, operated, and maintained in accordance with the most recent version of the *North Carolina Surface Mining Manual*.
  - The reclamation measures and implementation must comply with the reclamation in accordance with the requirements of the Sedimentation Pollution Control Act.
21. Sediment and erosion control measures shall not be placed in wetlands or waters unless otherwise approved by this Certification. [15A NCAC 02H.0506(b)(3) and (c)(3)]

Violations of any condition herein set forth may result in revocation of this Certification and may result in criminal and/or civil penalties. This Certification shall become null and void unless the above conditions are made conditions of the Federal 404 and/or Coastal Area Management Act Permit. This Certification shall expire upon the expiration of the 404 or CAMA permit.

If you wish to contest any statement in the attached Certification you must file a petition for an administrative hearing. You may obtain the petition form from the office of Administrative hearings. You must file the petition with the office of Administrative Hearings within sixty (60) days of receipt of this notice. A petition is considered filed when it is received in the office of Administrative Hearings during normal office hours. The Office of Administrative Hearings accepts filings Monday through Friday between the hours of 8:00am and 5:00pm, except for official state holidays. The original and one (1) copy of the petition must be filed with the Office of Administrative Hearings.

The petition may be faxed-provided the original and one copy of the document is received by the Office of Administrative Hearings within five (5) business days following the faxed transmission.

The mailing address for the Office of Administrative Hearings is:

Office of Administrative Hearings  
6714 Mail Service Center  
Raleigh, NC 27699-6714  
Telephone: (919) 431-3000, Facsimile: (919) 431-3100

A copy of the petition must also be served on DEQ as follows:

Mr. Bill Lane, General Counsel  
Department of Environmental Quality  
1601 Mail Service Center



**P-18**

This the 26th day of July 2017

DIVISION OF WATER RESOURCES

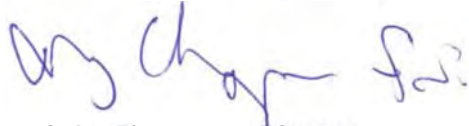

S. Jay Zimmerman, Director

WQC No. WQC004123

See Sheet 1A For Index of Sheets  
See Sheet 1B For Conventional Symbols

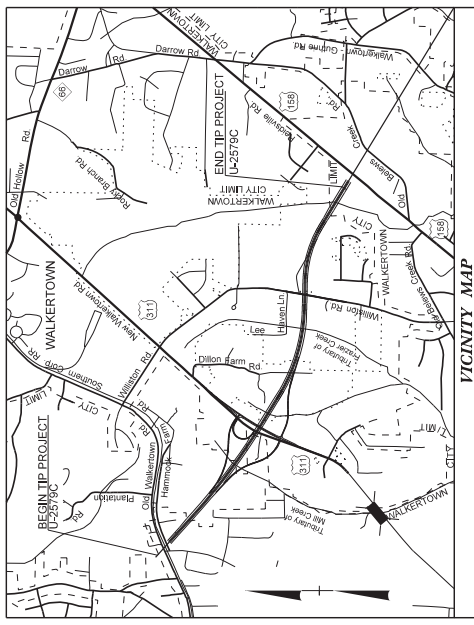

STATE OF NORTH CAROLINA  
DIVISION OF HIGHWAYS  
**FORSYTH COUNTY**

**LOCATION:** WINSTON - SALEM NORTHERN BELTWAY (EASTERN SECTION)  
FROM US 311 TO US 158 (FUTURE I-74)

**TYPE OF WORK:** WIDENING, GRADING, PAVING, DRAINAGE, SIGNING, SIGNALS,  
ITS, CULVERTS AND STRUCTURES.

STATE	N.C.	PROJECT NUMBER	U-2579C	DATE	1
PROJECT NUMBER	34839.1.9	DESCRIPTION	PE		
	34839.2.6		R/W		
	34839.2.GV1B		N/A		
	34839.2.16		N/A		
	34839.3.GV6		UTIL		
			CONSTR.		

**WETLAND AND SURFACE WATER IMPACTS PERMIT**

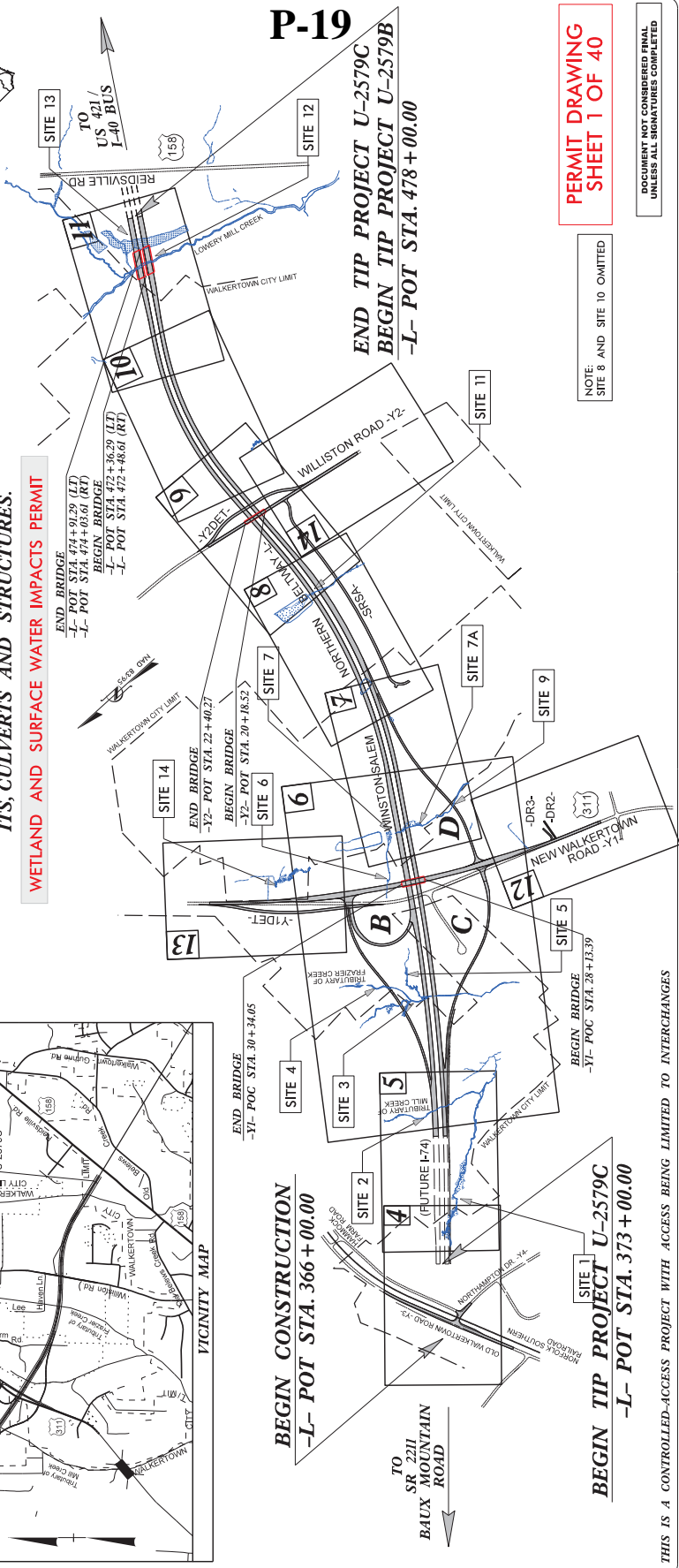

**BEGIN CONSTRUCTION**  
-L- POT STA. 366+00.00

**BEGIN TIP PROJECT U-2579C**  
-L- POT STA. 373+00.00

**END TIP PROJECT U-2579C**  
**BEGIN TIP PROJECT U-2579B**  
-L- POT STA. 478+00.00

**P-19**

THIS IS A CONTROLLED-ACCESS PROJECT WITH ACCESS BEING LIMITED TO INTERCHANGES

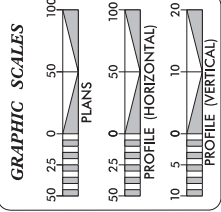

**DESIGN DATA**

ADT 2017	= 65,592
ADT 2037	= 93,112
K	= 10 %
D	= 60 %
T	= 18 % *
V	= 70 MPH
*(TTST = 12% + DUAL = 6%)	
FUNC CLASS	= INTERSTATE

**PROJECT LENGTH**

LENGTH OF ROADWAY PROJECT U-2579C	= 1.989 Miles
LENGTH OF STRUCTURE PROJECT U-2579C	= 0.040 Mile
TOTAL LENGTH OF TIP PROJECT U-2579C	= 1.949 Miles

PLANS PREPARED BY:  
8601 SIX FORKS RD. SUITE 210  
RALEIGH, NC 27612  
919-926-1800

FOR THE NORTH CAROLINA DEPARTMENT OF TRANSPORTATION  
2017 STANDARD SPECIFICATIONS

**RIGHT OF WAY DATE:**  
OCTOBER 28, 2015

**LETTING DATE:**  
OCTOBER 17, 2017

HYDRAULICS ENGINEER

ROADWAY DESIGN ENGINEER

NOTES:  
SITE 8 AND SITE 10 OMITTED

DOCUMENT NOT CONSIDERED FINAL UNLESS ALL SIGNATURES COMPLETED



**TIP PROJECT: U-2579C**

**CONTRACT:**

**PERMIT DRAWING**  
**SHEET 1 OF 40**

# P-20

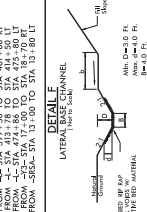
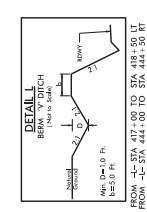
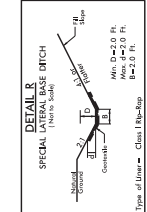
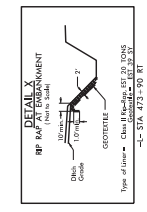
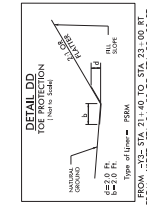
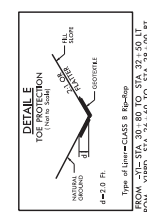
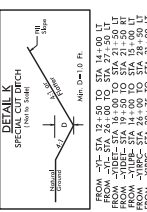
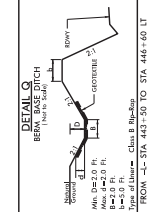
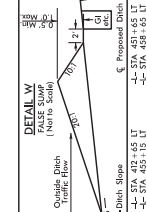
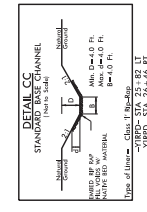
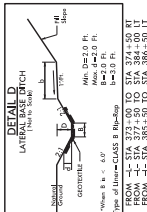
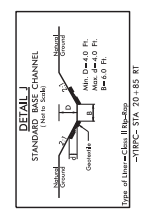
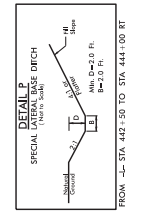
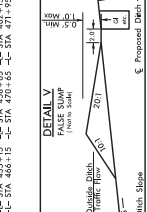
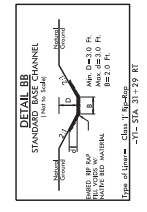
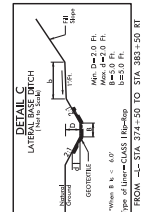
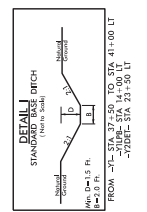
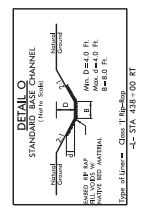
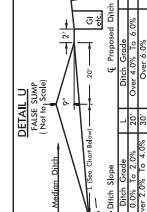
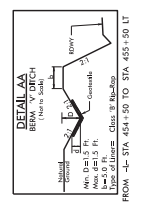
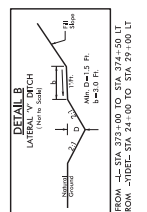
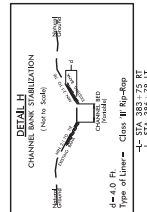
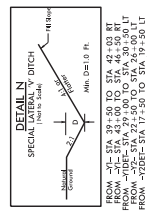
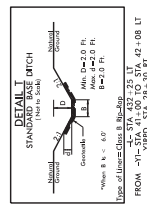
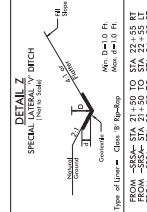
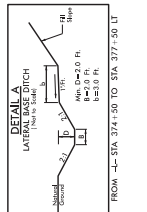
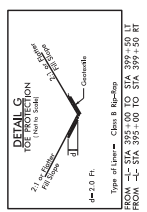
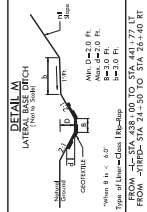
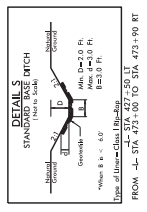
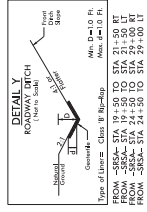





DOCUMENT NOT CONSIDERED FINAL  
 UNLESS ALL SIGNATURES COMPLETED  
**PERMIT DRAWING**  
**SHEET 5 OF 40**

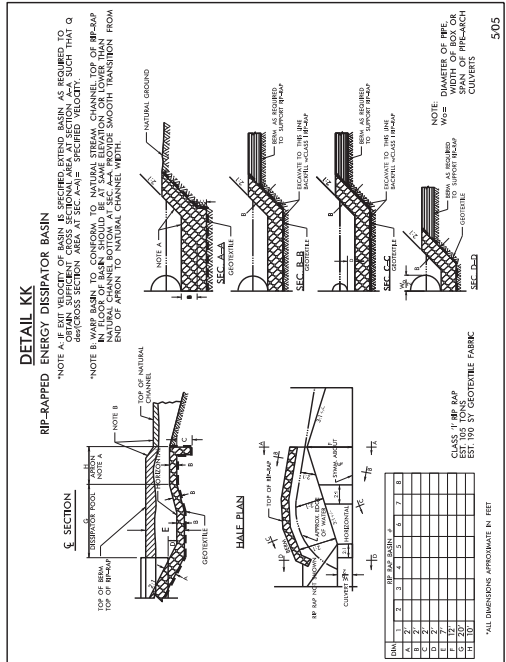
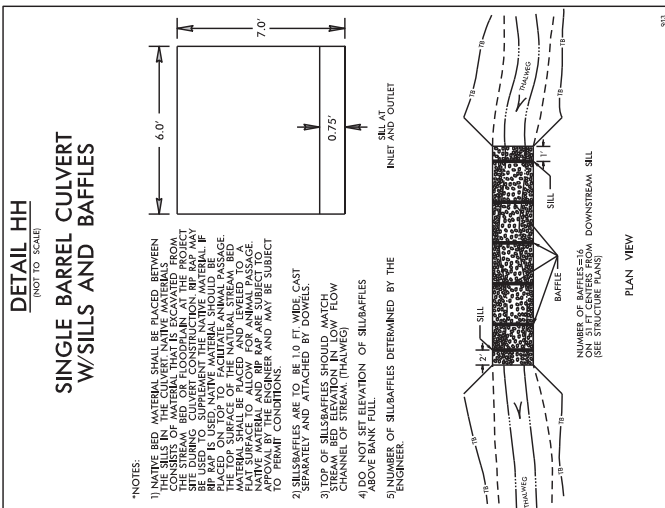
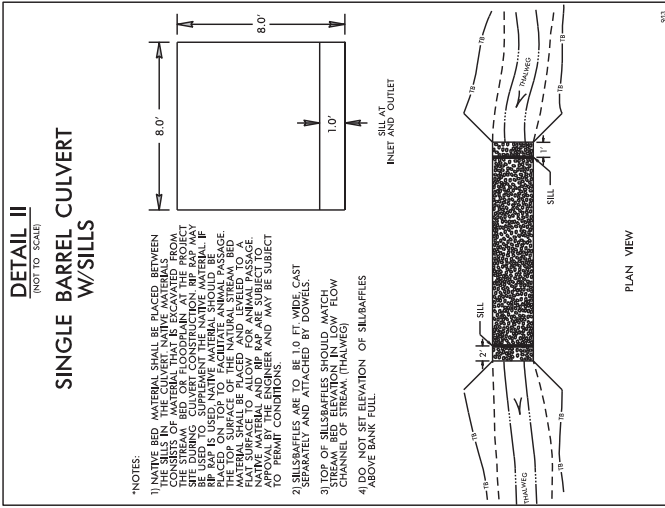
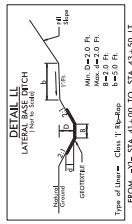
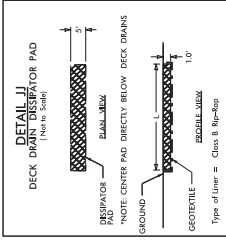







PROJECT REFERENCE NO. U-2579C	SHEET NO. 6
ROADWAY DESIGN ENGINEER	HYDRAULICS ENGINEER

PERMIT DRAWING  
SHEET 15 OF 40

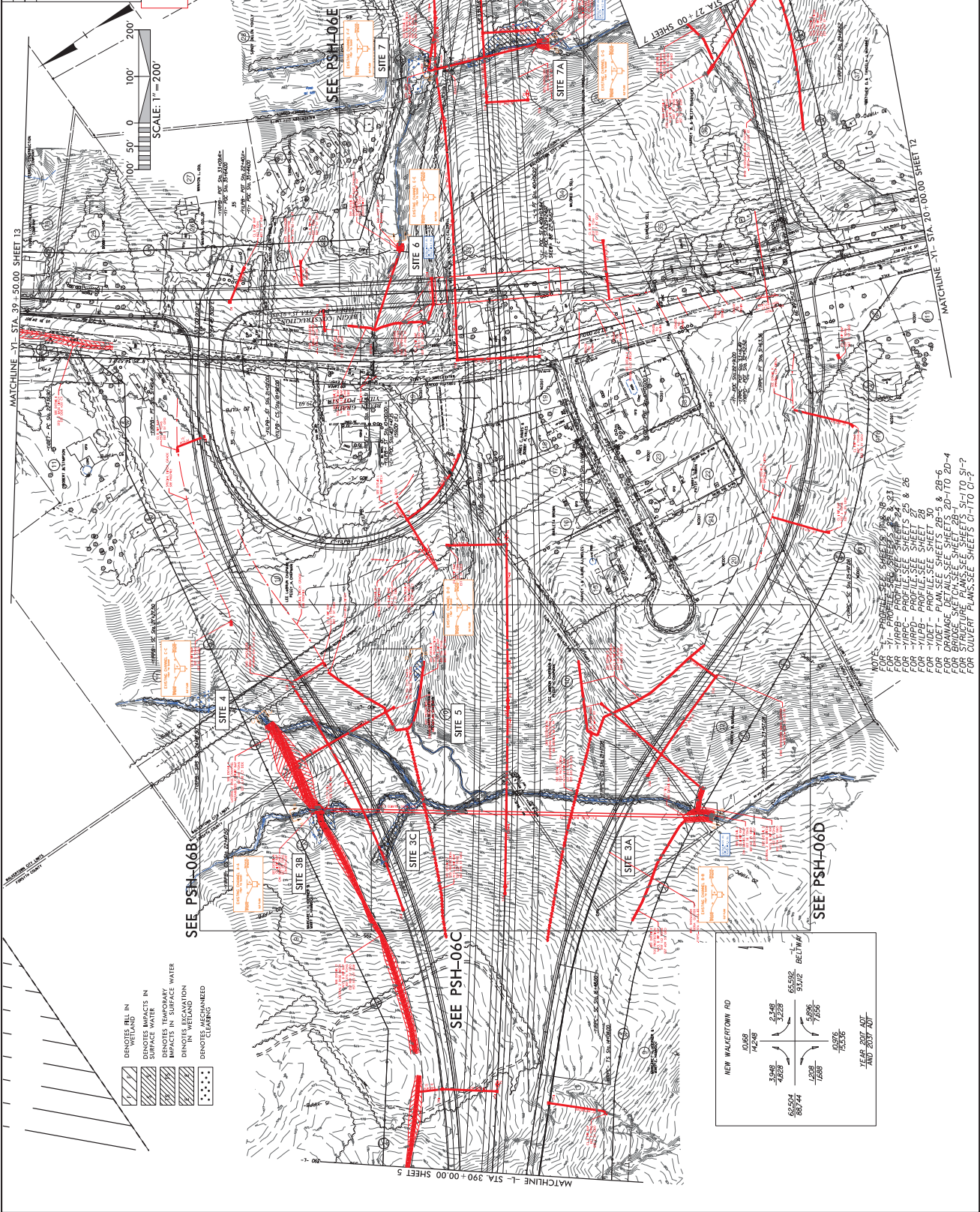

- DENOTES FILL IN WETLAND
- DENOTES IMPACTS IN SURFACE WATER
- DENOTES TEMPORARY IMPACTS IN SURFACE WATER
- DENOTES RECREATION IN WETLAND
- DENOTES MECHANIZED CLOSING

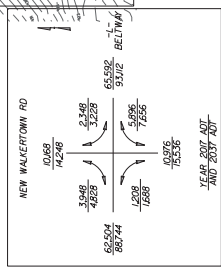

NOTE:  
 FOR -Y1P - PROFILE SEE SHEETS 25 & 26  
 FOR -Y1PB - PROFILE SEE SHEET 25  
 FOR -Y1PD - PROFILE SEE SHEET 26  
 FOR -Y1PE - PROFILE SEE SHEET 26  
 FOR -Y1PF - PROFILE SEE SHEET 26  
 FOR -Y1PG - PROFILE SEE SHEET 26  
 FOR -Y1PH - PROFILE SEE SHEET 26  
 FOR -Y1PI - PROFILE SEE SHEET 26  
 FOR -Y1PJ - PROFILE SEE SHEET 26  
 FOR -Y1PK - PROFILE SEE SHEET 26  
 FOR -Y1PL - PROFILE SEE SHEET 26  
 FOR -Y1PM - PROFILE SEE SHEET 26  
 FOR -Y1PN - PROFILE SEE SHEET 26  
 FOR -Y1PO - PROFILE SEE SHEET 26  
 FOR -Y1PP - PROFILE SEE SHEET 26  
 FOR -Y1PQ - PROFILE SEE SHEET 26  
 FOR -Y1PR - PROFILE SEE SHEET 26  
 FOR -Y1PS - PROFILE SEE SHEET 26  
 FOR -Y1PT - PROFILE SEE SHEET 26  
 FOR -Y1PU - PROFILE SEE SHEET 26  
 FOR -Y1PV - PROFILE SEE SHEET 26  
 FOR -Y1PW - PROFILE SEE SHEET 26  
 FOR -Y1PX - PROFILE SEE SHEET 26  
 FOR -Y1PY - PROFILE SEE SHEET 26  
 FOR -Y1PZ - PROFILE SEE SHEET 26

- PROP. CONCRETE 5' MONOLITHIC ISLAND
- PAVED SHOULDER



PROJECT REFERENCE NO. R-2579C  
 SHEET NO. 6E  
 HYDRAULICS ENGINEER  
 ROADWAY DESIGN ENGINEER  
 INCOMPLETE PLANS  
 DO NOT USE FOR CONSTRUCTION

PERMIT DRAWING  
 SHEET 19 OF 40

# P-26

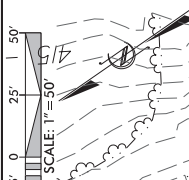

**SITE 7**

SEE DETAIL BB  
 STANDARD-BASE CHANNEL  
 WITH REINFORCED CL RIP RAP  
 EST 23 TONS  
 LENGTH = 15'  
 PROP. WW FENCE  
 DO NOT BURY  
 INVERT

DO NOT BURY  
 INVERT

SEE DETAIL E  
 TOE PROTECTION  
 WITH CL RIP RAP  
 EST 42 TONS  
 EST 112 SY GEO

**SITE 6**

CI (D)=8.2 cfs  
 V (D)=14.7 ffs

**SITE 7A**

BEG. SHOULDER  
 BERM GUTTER  
 STA. 413+50.4 RT

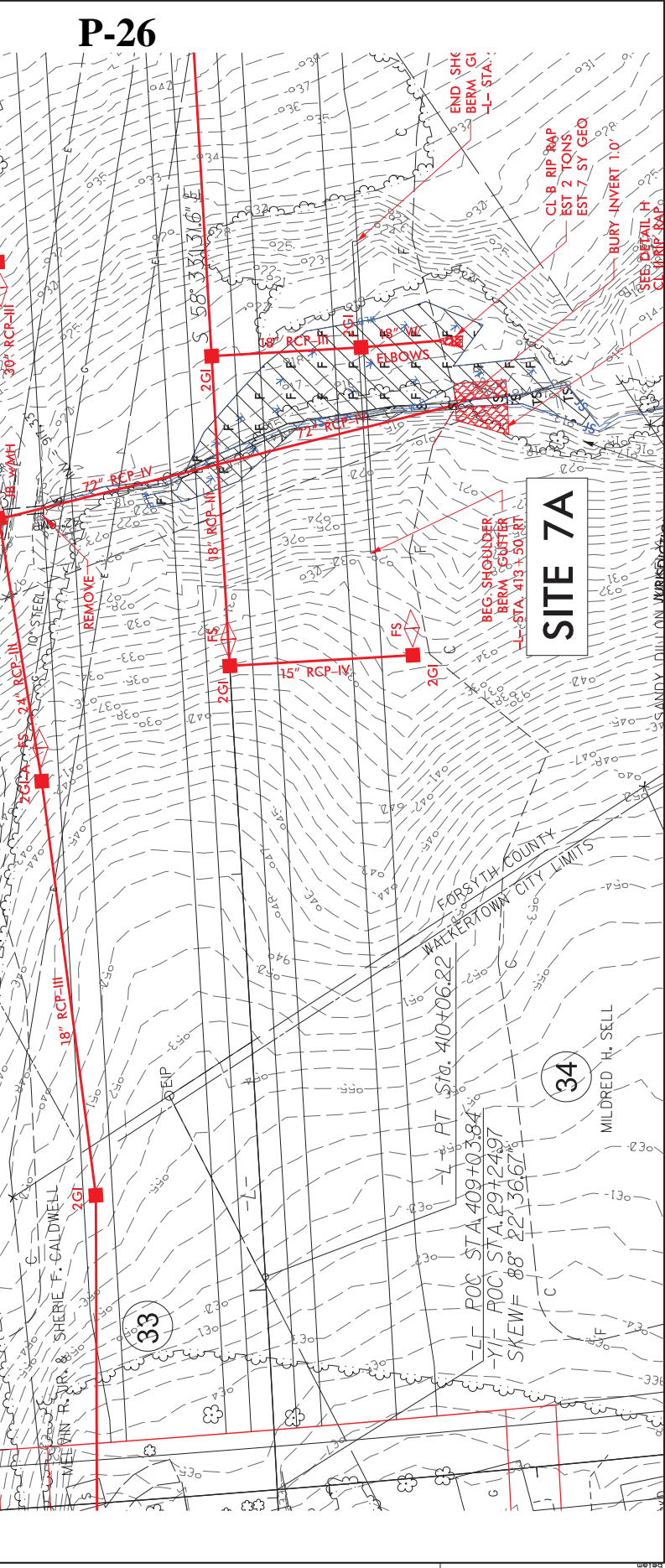

8/17/99

REVISIONS

12/20/2017 Hhd:pm-wet.psh:Design

**PERMIT DRAWING  
 SHEET 23 OF 40**

**SITE 7A**

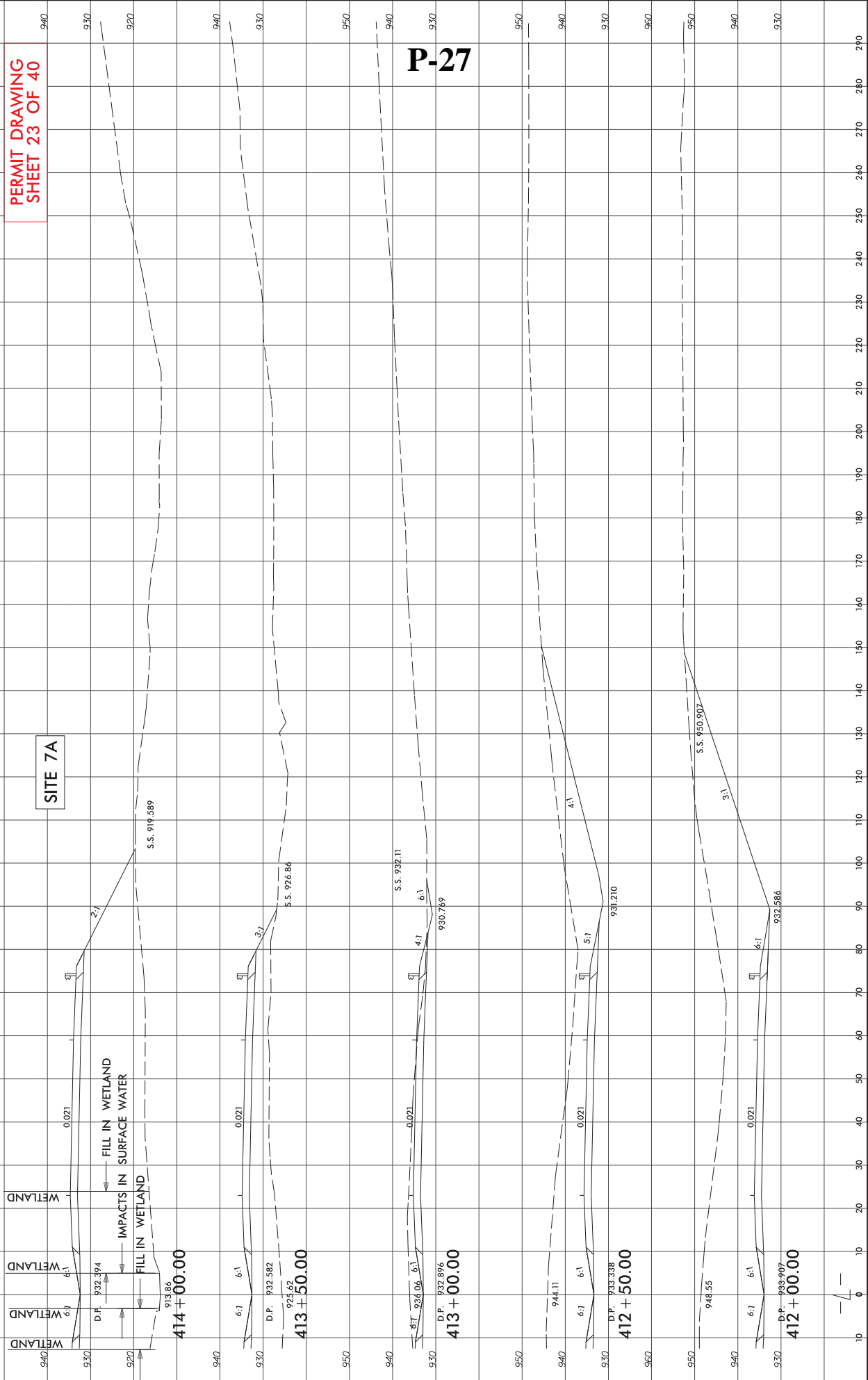

**P-27**

**414 + 00.00**

**413 + 50.00**

**413 + 00.00**

**412 + 50.00**

**412 + 00.00**



300 200 100 0 100 200 300

PERMIT DRAWING  
 SHEET 25 OF 40

413+97 -L-

P-28

SITE 7

SITE 7A

950 940 930 920 910

INV IN = 916.0

72" RCP  
 SLOPE = 1.45%

INV OUT = 911.5  
 BURY 1 FT

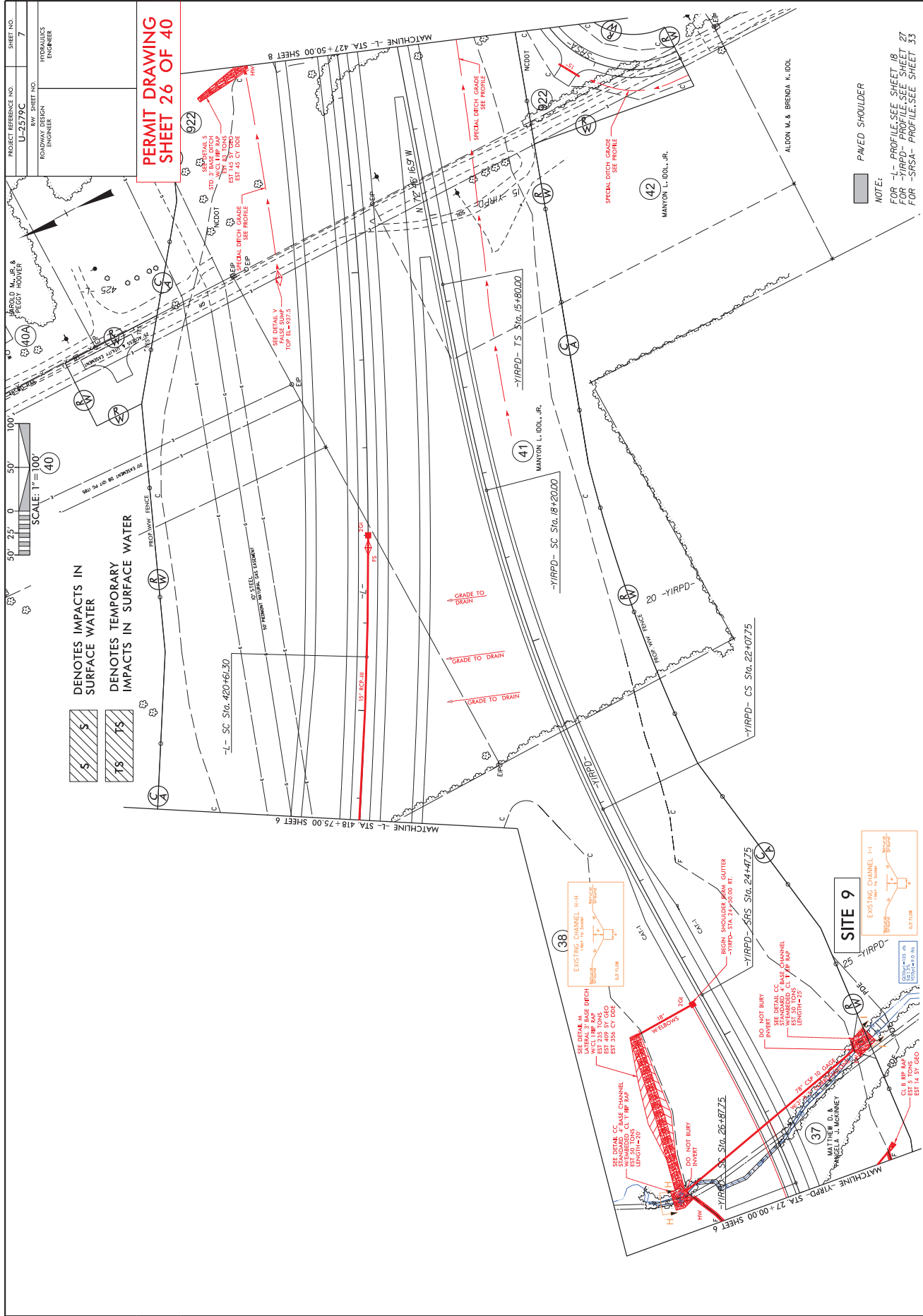

PROJECT REFERENCE NO.	U-2579C	SHEET NO.	7
ROADWAY DESIGN ENGINEER	HYDRAULICS ENGINEER		

**PERMIT DRAWING  
SHEET 26 OF 40**

DENOTES IMPACTS IN SURFACE WATER  
 DENOTES TEMPORARY IMPACTS IN SURFACE WATER

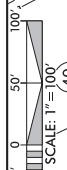

PAVED SHOULDER  
 NOTE:  
 FOR L-1 PROFILE SEE SHEET 18  
 FOR Y-IRPD PROFILE SEE SHEET 27  
 FOR S-RSA PROFILE SEE SHEET 33



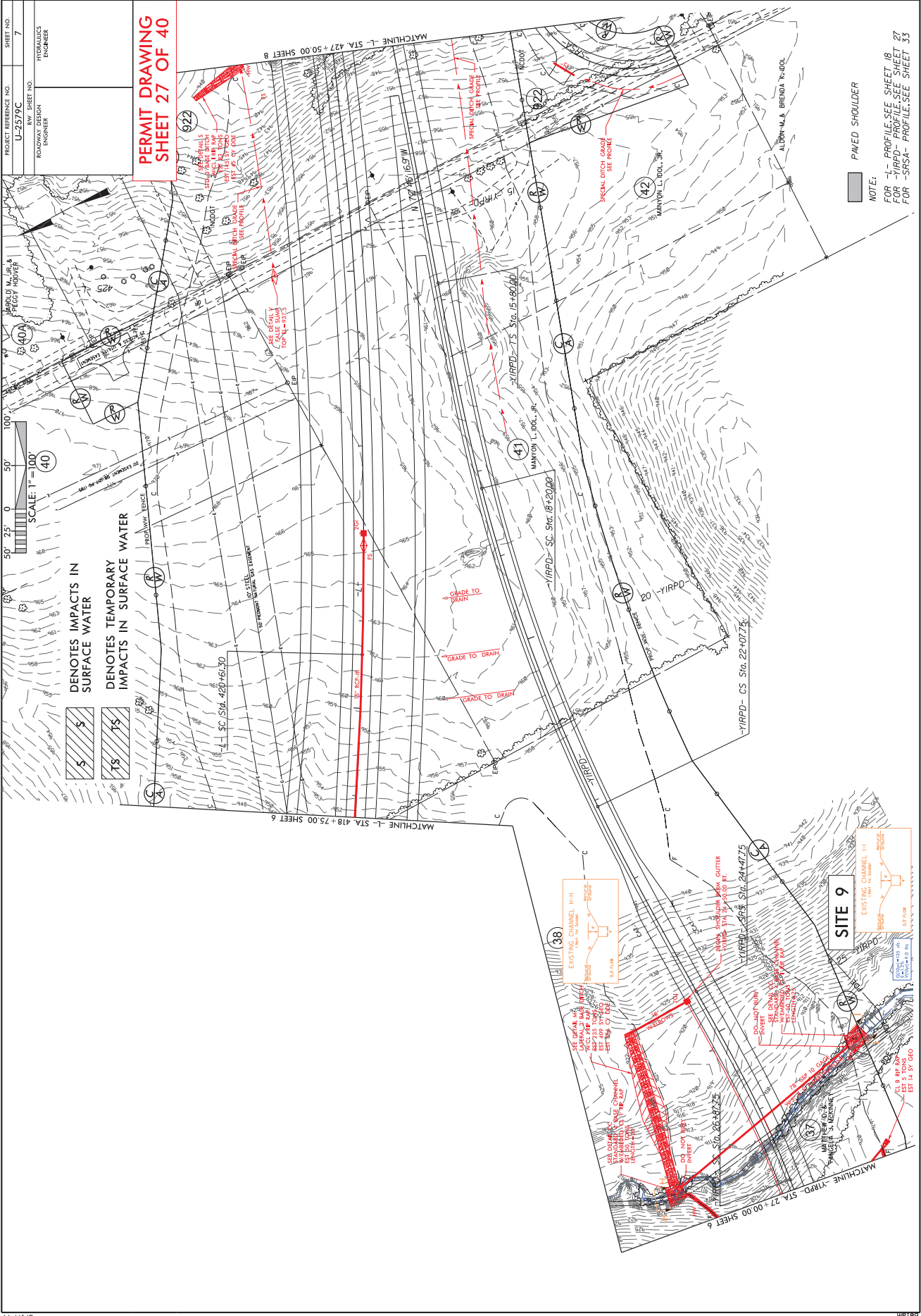

**PERMIT DRAWING  
SHEET 27 OF 40**

NOTE:  
FOR -L- PROFILE, SEE SHEET 18  
FOR -YIRPD- PROFILE, SEE SHEET 27  
FOR -SRA- PROFILE, SEE SHEET 33

PAVED SHOULDER

DENOTES IMPACTS IN  
SURFACE WATER

DENOTES TEMPORARY  
IMPACTS IN SURFACE WATER

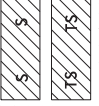

PROJECT REFERENCE NO.	U-2579C
ROADWAY DESIGN ENGINEER	
SHEET NO.	7

PROJECT REFERENCE NO. U-2579C  
ROADWAY DESIGN ENGINEER  
SHEET NO. 7

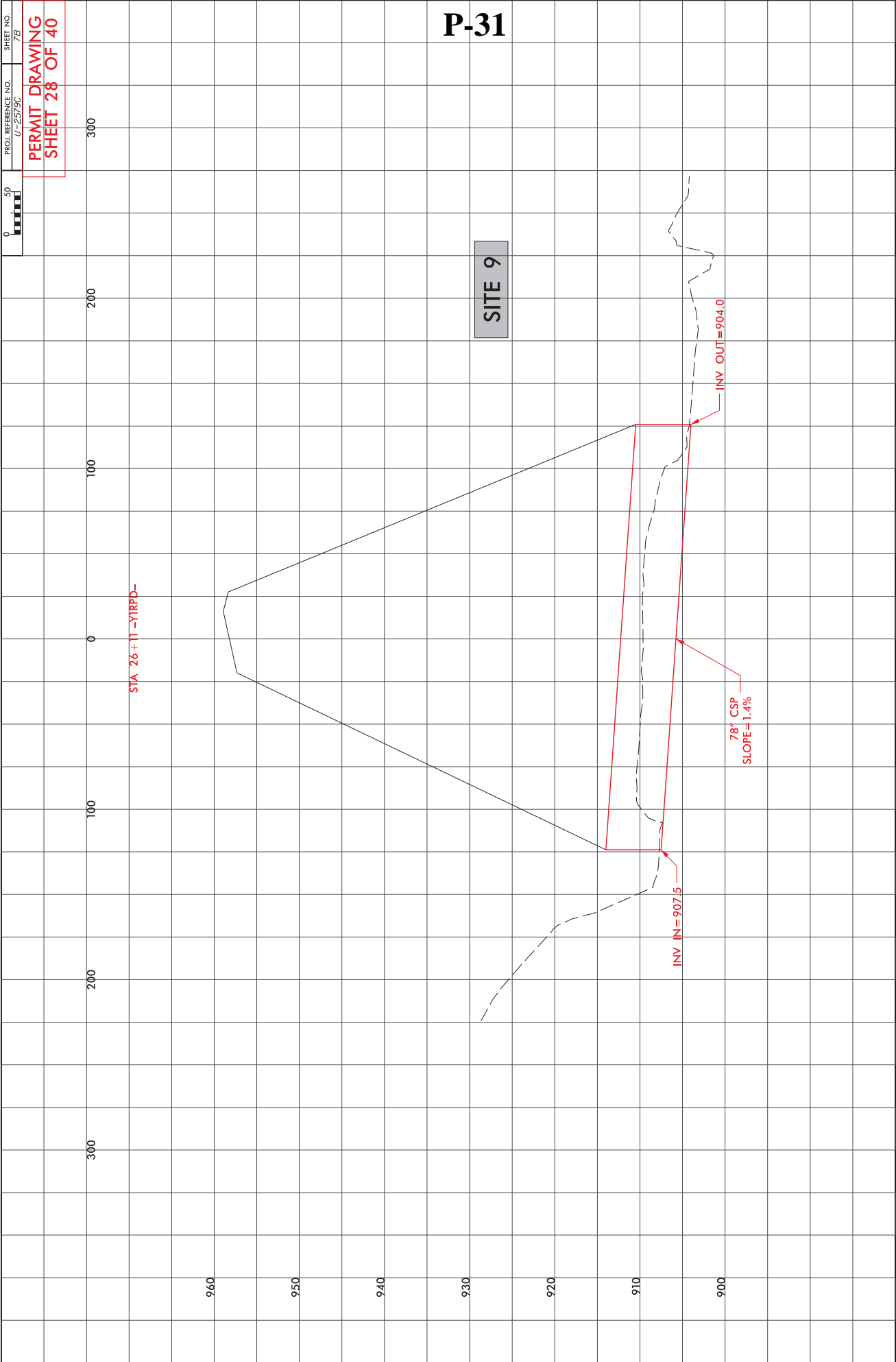

PROJECT REFERENCE NO.	U-2579C
SHEET NO.	8
BY	HYDRAULICS ENGINEER
DATE	
DESIGNED BY	ROADWAY DESIGN ENGINEER

DOCUMENT NOT CONSIDERED FINAL UNLESS ALL SIGNATURES COMPLETED

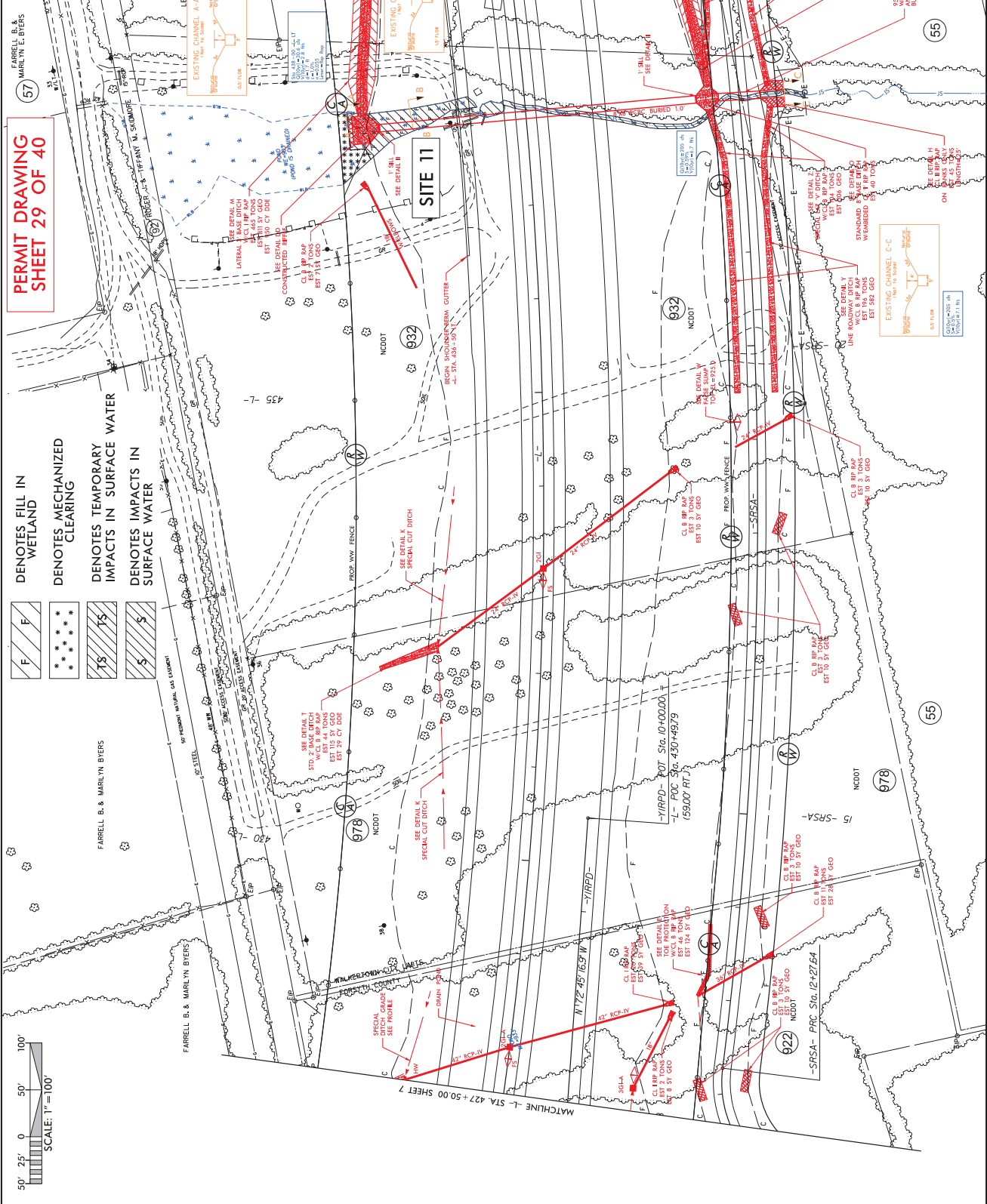

PERMIT DRAWING SHEET 29 OF 40

- DENOTES FILL IN WETLAND
- DENOTES MECHANIZED CLEARING
- DENOTES TEMPORARY IMPACTS IN SURFACE WATER
- DENOTES IMPACTS IN SURFACE WATER

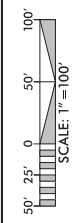

NOTE: L- PROFILE SEE SHEET 18 FOR PAVED SHOULDER FOR SRS-A PROFILE SEE SHEET 33

RIGHT OF WAY REVISION 5/31/17 - REVISED C/A FROM -L- STA. 436+00.00 TO STA. 440+00.00 RT. ON PARCELS 55, 922, 932, 977, AND 978. ADDED TCE ON PARCELS 55 AND 932. ADDED POE ON PARCEL 55. JWB



PROJECT REFERENCE NO.	U-2579C
SHEET NO.	8
FARRELL B. & MARLYN BYERS	
ROADWAY DESIGN ENGINEER	
HYDRAULICS ENGINEER	
DOCUMENT NOT CONSIDERED FINAL UNLESS ALL SIGNATURES COMPLETED	

**PERMIT DRAWING SHEET 30 OF 40**

- DENOTES FILL IN WETLAND
- DENOTES MECHANIZED CLEARING
- DENOTES TEMPORARY IMPACTS IN SURFACE WATER
- DENOTES IMPACTS IN SURFACE WATER

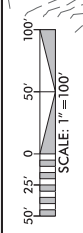
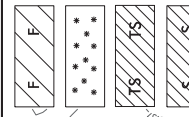

8/17/99

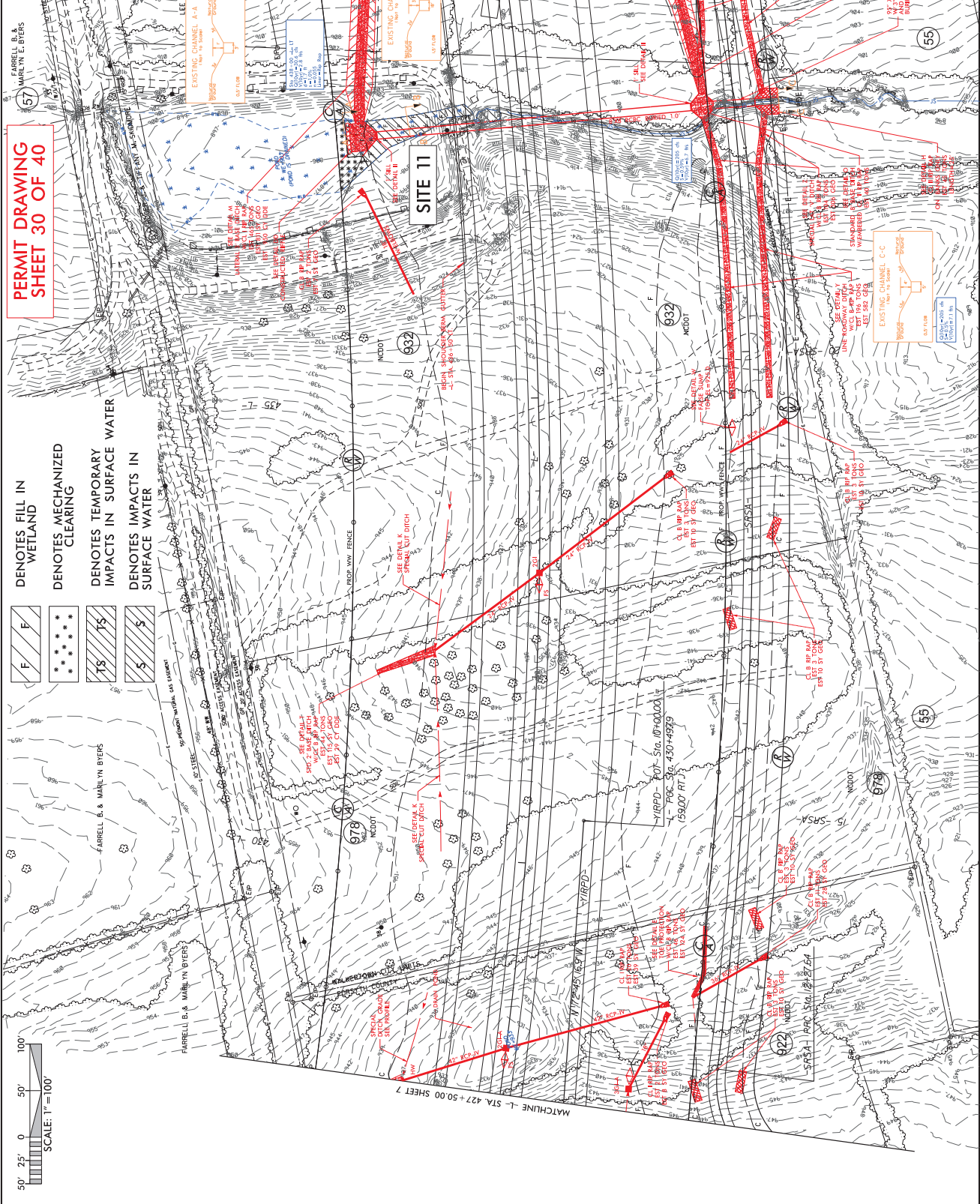

RIGHT OF WAY REVISION 5/31/77 - REVISED C/A FROM -L- STA. 436+00.00 TO STA. 440+00.00 RT. ON PARCELS 932 AND 977; ADDED R/W ON PARCELS 55, 922, 932, 977. AND 978; ADDED TCE ON PARCELS 55 AND 932; ADDED POE ON PARCEL 55. JWB

10872077.dwg pml.vet.psh.kel.Bbdgdn

NOTE: FOR PROFILES SEE SHEET 18 FOR SRS-A PROFILES SEE SHEET 33 FOR SRS-A



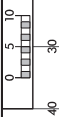

**SITE 11**

**P-34**

**438+00.00**

**437+50.00**

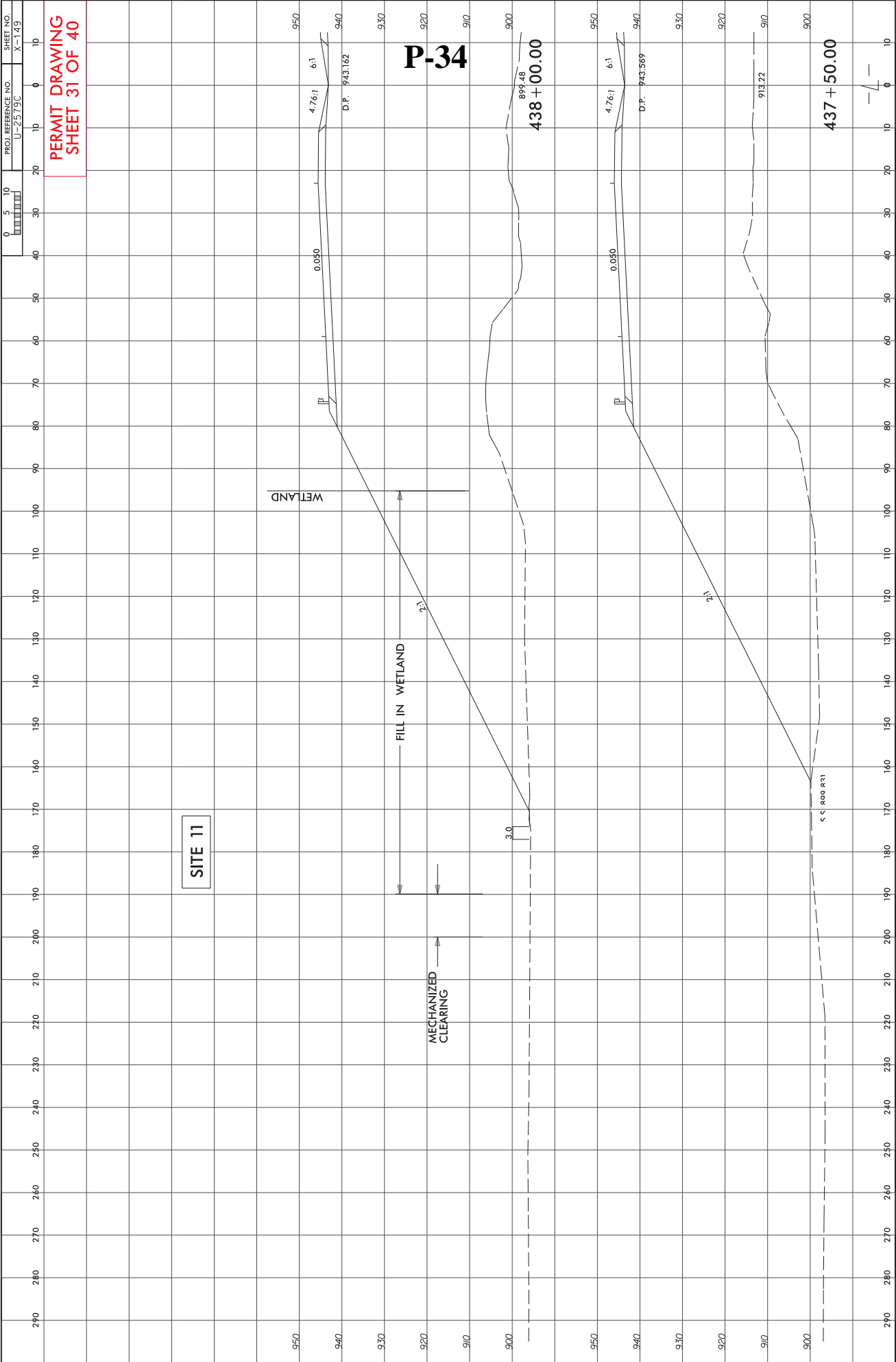



300 200 100 0 100 200 300

437 + 98 -L-

22 + 71.06 -SRSA-

PERMIT DRAWING  
 SHEET 32 OF 40

# P-35

SITE 11

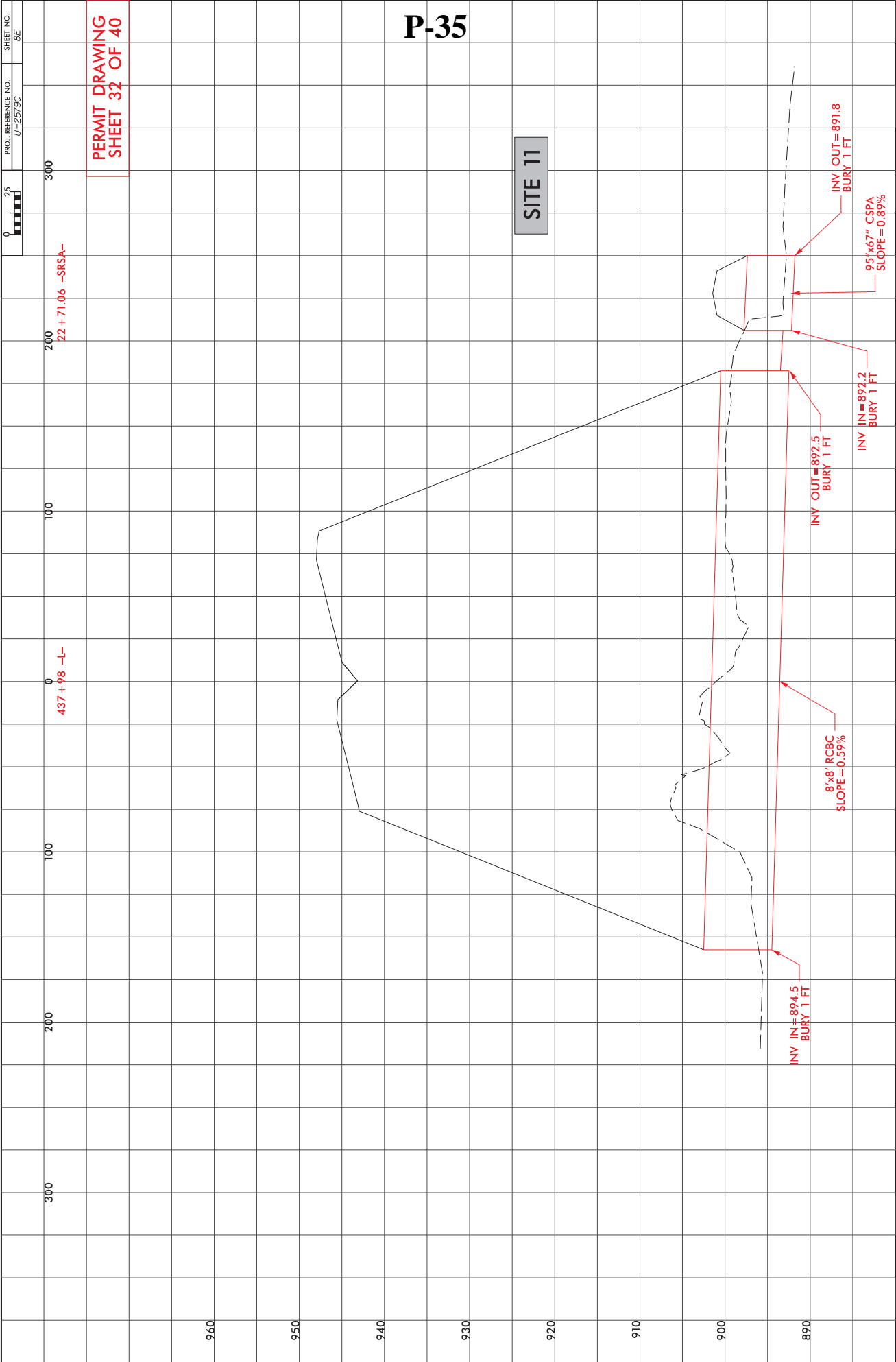

PROJECT REFERENCE NO. U-2579C  
 SHEET NO. 11  
 ROADWAY DESIGN ENGINEER  
 HYDRAULICS ENGINEER

DOCUMENT NOT CONSIDERED FINAL  
 UNLESS ALL SIGNATURES COMPLETED  
**PERMIT DRAWING**  
**SHEET 33 OF 40**

# P-36

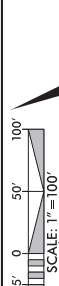

- DENOTES FILL IN WETLAND
- DENOTES MECHANIZED CLEARING
- DENOTES IMPACTS IN SURFACE WATER
- DENOTES TEMPORARY IMPACTS IN SURFACE WATER
- DENOTES FILL IN WETLAND

MICHAEL W. WESTMORELAND & WADE WESTMORELAND  
 JANE WHICKER & DAN WESTMORELAND  
 WALKERTOWN CITY ENGINEERS  
 1000 W. MARKET STREET  
 WALKERTOWN, OHIO 43081  
 (614) 885-1100



PAVED SHOULDER

NOTE:  
 FOR -L- PROFILE SEE SHEETS 19 & 20  
 FOR BRIDGE SKETCH SEE SHEET 28-2  
 FOR DRAINAGE DETAILS SEE SHEETS 20-4  
 FOR STRUCTURE PLANS SEE SHEETS 33-1 TO 33-2  
 FOR STRUCTURE PLANS SEE SHEETS 34-1 TO 34-2

PROJECT REFERENCE NO. U-2579C  
 SHEET NO. 11  
 RW SHEET NO.  
 ROADWAY DESIGN ENGINEER  
 HYDRAULICS ENGINEER

DOCUMENT NOT CONSIDERED FINAL  
 UNLESS ALL SIGNATURES COMPLETED  
**PERMIT DRAWING**  
**SHEET 34 OF 40**

# P-37

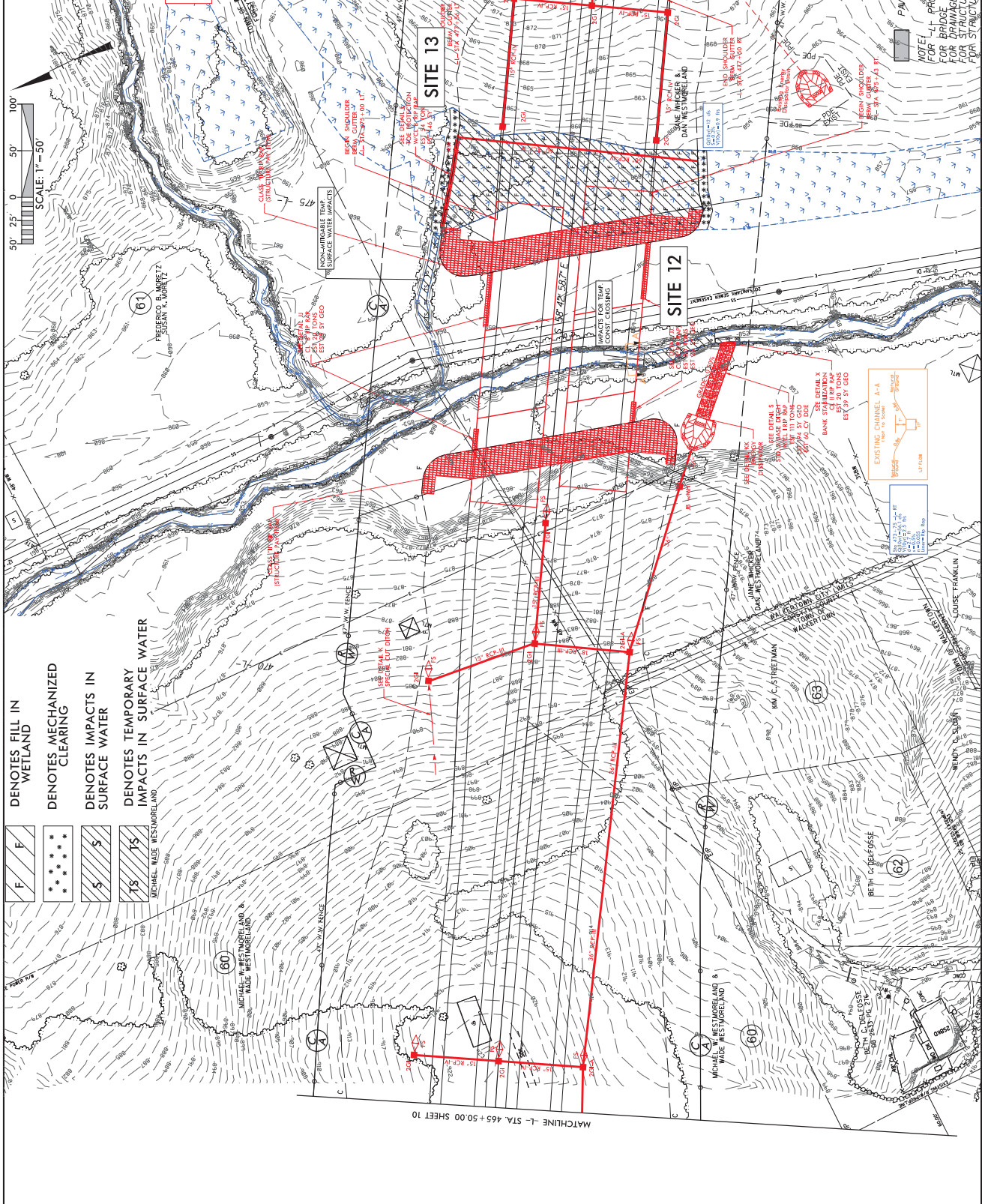

F F DENOTES FILL IN WETLAND  
 \* \* \* DENOTES MECHANIZED CLEARING  
 S S DENOTES IMPACTS IN SURFACE WATER  
 TS TS DENOTES TEMPORARY IMPACTS IN SURFACE WATER

MICHAEL W. WESTMORELAND  
 WALKER TOWN

NOTE: - LT PROFILE SEE SHEETS 19 & 20 FOR BRIDGE DETAILS. SEE SHEET 22 FOR DRAINAGE DETAILS. SEE SHEETS 20-24 FOR STRUCTURE PLANS. SEE SHEETS 18-19-20-21 FOR STRUCTURE PLANS. SEE SHEETS 18-19-20-21 FOR PAVED SHOULDER.

MATCHLINE - STA. 465+50.00 SHEET 10



**PERMIT DRAWING  
 SHEET 36 OF 40**

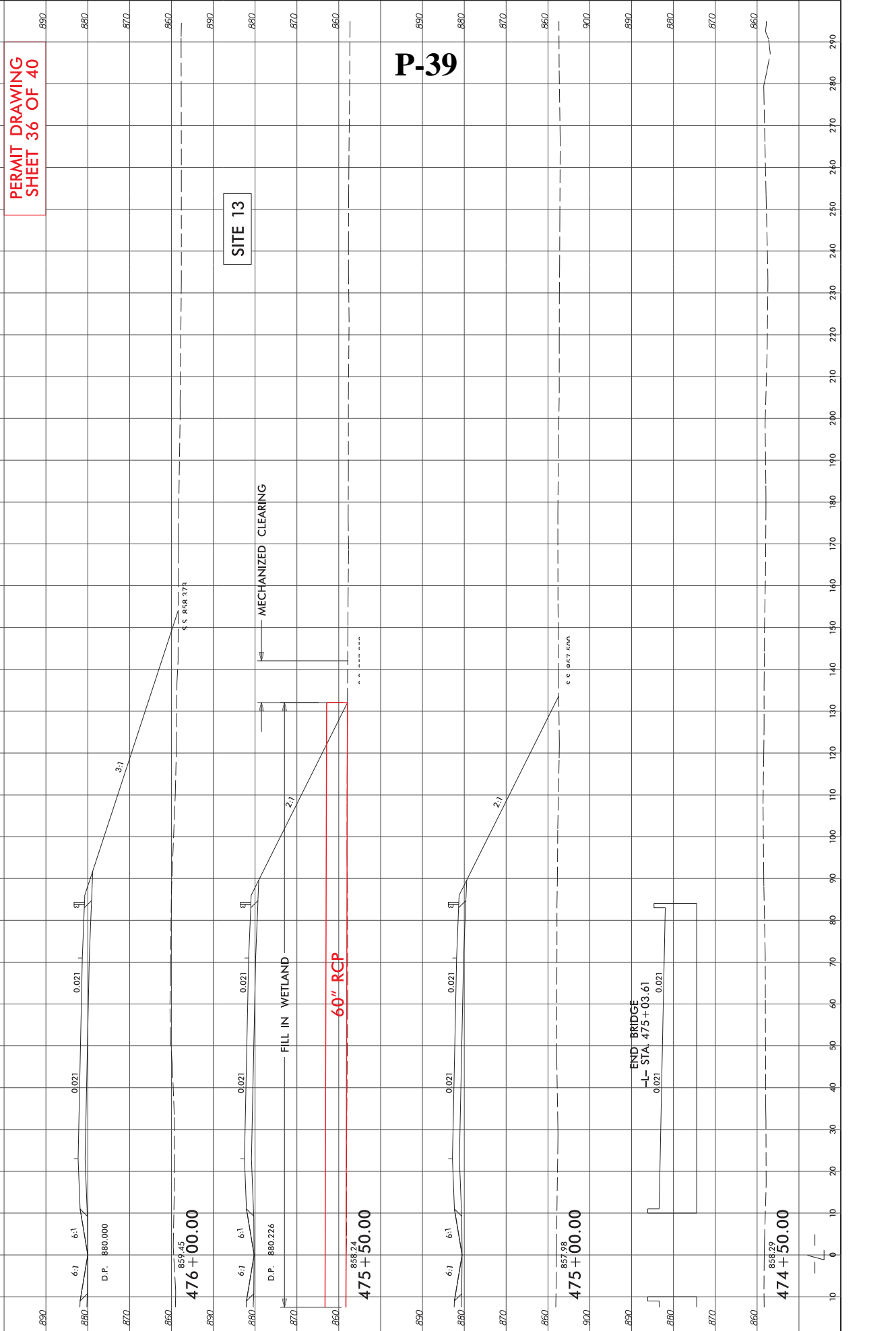

**P-39**





PERMIT DRAWING  
 SHEET 37 OF 40

SITE 13

WETLAND

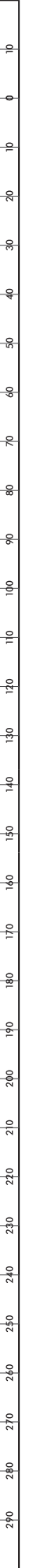
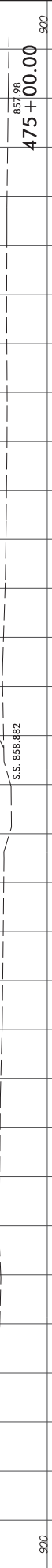
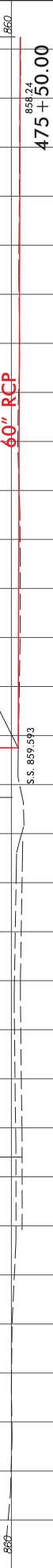

PROJECT REFERENCE NO. U-2579C  
 SHEET NO. 13  
 RW SHEET NO. HYDRAULICS ENGINEER  
 ROADWAY DESIGN ENGINEER

DOCUMENT NOT CONSIDERED FINAL  
 UNLESS ALL SIGNATURES COMPLETED  
**PERMIT DRAWING**  
**SHEET 38 OF 40**



# P-41

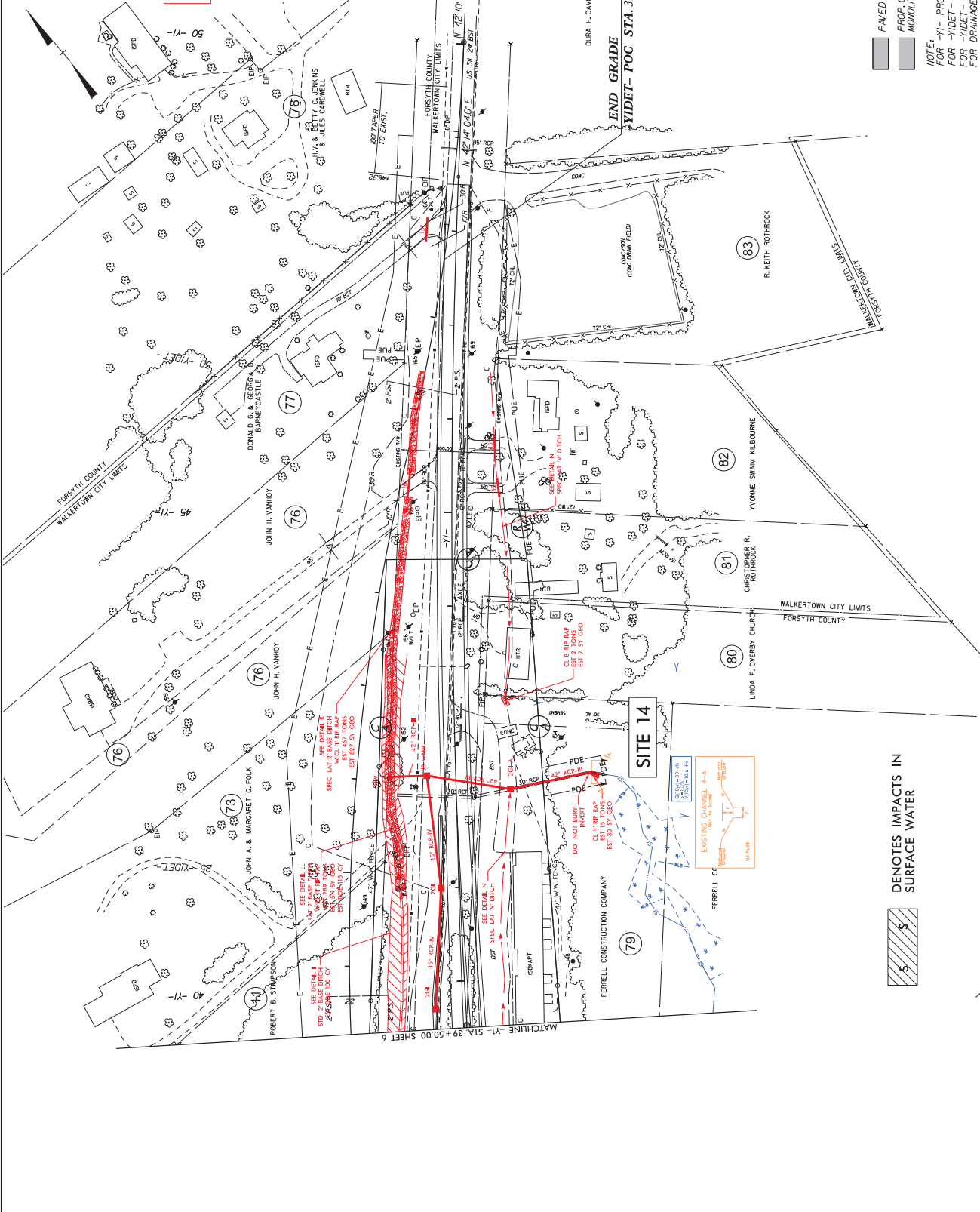

- PAVED SHOULDER
- PROP. CONCRETE, 5"
- MONOLITHIC ISLAND

NOTE: -YI- PROFILE SEE SHEET 23  
 FOR -YIDET- PROFILE SEE SHEET 30  
 FOR -YIDET- PLAN SEE SHEET 28-5 & 28-6  
 FOR DRAINAGE DETAILS SEE SHEETS 20-1 TO 20-4

DENOTES IMPACTS IN  
 SURFACE WATER

**SITE 14**

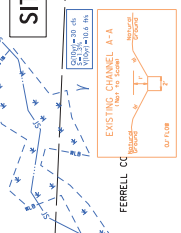



PROJECT REFERENCE NO. U-2579C  
 SHEET NO. 13  
 RW SHEET NO. HYDRAULICS ENGINEER  
 ROADWAY DESIGN ENGINEER

DOCUMENT NOT CONSIDERED FINAL  
 UNLESS ALL SIGNATURES COMPLETED  
**PERMIT DRAWING**  
**SHEET 39 OF 40**



P-42

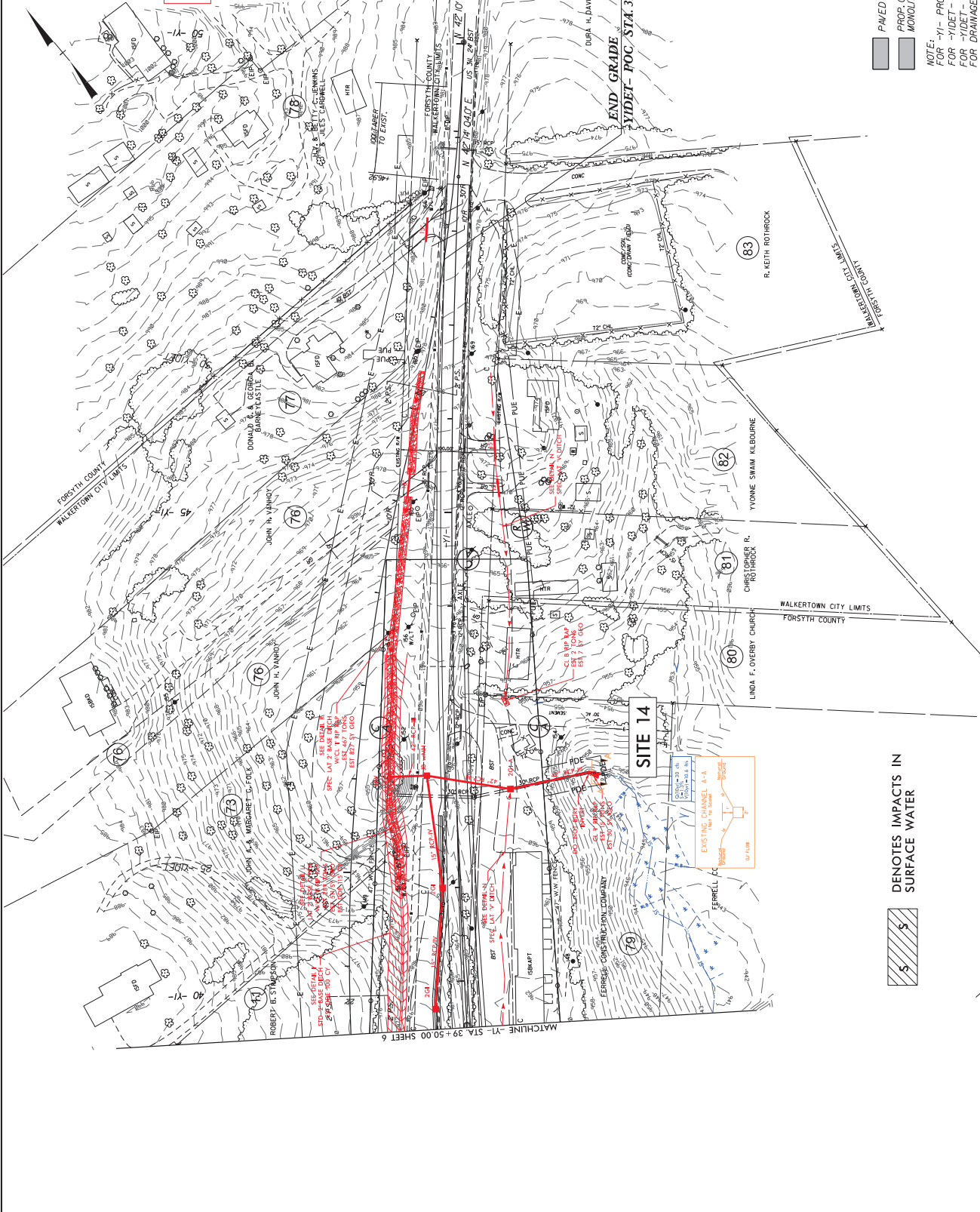

- PAVED SHOULDER
- PROP. CONCRETE 5'
- MONOLITHIC ISLAND

NOTE: -YI- PROFILE SEE SHEET 23  
 FOR -YIDET- PROFILE SEE SHEET 30  
 FOR -YIDET- PLAN SEE SHEET 28-5 & 28-6  
 FOR DRAINAGE DETAILS SEE SHEETS 20-110 20-4

■ DENOTES IMPACTS IN  
 SURFACE WATER

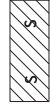

WETLAND PERMIT IMPACT SUMMARY																			
Site No.	Station (From/To)	Structure Size / Type	WETLAND IMPACTS						SURFACE WATER IMPACTS										
			Permanent Fill In Wetlands (ac)	Temp. Fill In Wetlands (ac)	Excavation in Wetlands (ac)	Mechanized Clearing in Wetlands (ac)	Hand Clearing in Wetlands (ac)	Permanent SW impacts (ac)	Temp. SW impacts (ac)	Existing Channel Impacts Permanent (ft)	Existing Channel Impacts Temp. (ft)	Natural Stream Design (ft)							
6	31+27-31+55 -Y1- RT	ROADWAY FILL																	
		CHANNEL STABILIZATION (Downstream)																	
7	412+70-413+13 -L- LT	ROADWAY FILL																	
7A	412+78-413+69 -L- RT	72" RCP	0.14																
		BANK STABILIZATION (Downstream)																	
9	25+72-26+61 -Y1RPD-	78" CSP																	
		CHANNEL STABILIZATION																	
11	437+58-238+22 -L-	8'x8' RCBC / 95" x 67" CSPA	0.08																
		BANK STABILIZATION (Downstream)																	
12	473+37-473+94 -L- RT	BRIDGE (Temp. Const. Crossing)																	
		BANK STABILIZATION																	
13	474+89-476+00 -L-	ROADWAY FILL	0.57																
14	42+15 -Y1-	42" RCP CHANNEL STABILIZATION																	
<b>TOTALS*:</b>			0.79			0.09					0.10	0.04	997	199	0				

\*Rounded totals are sum of actual impacts

NOTES:

- Site 8 Omitted
- Site 9: Upstream Channel Stabilization = 0.003 AC / 20 LF, Downstream Channel Stabilization = 0.004 AC / 25 LF
- Site 10 Omitted
- Site 13: Non-Mitigable Temporary Surface Water Impacts = 0.019 AC / 110 LF

NC DEPARTMENT OF TRANSPORTATION  
 DIVISION OF HIGHWAYS  
 May 11, 2017  
 FORSYTH  
 U-2579C  
 34839.3.6

See Sheet 1A For Index of Sheets  
See Sheet 1B For Conventional Symbols

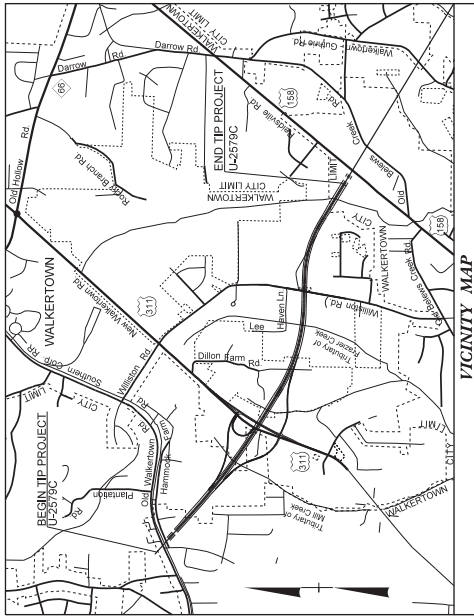

STATE OF NORTH CAROLINA  
DIVISION OF HIGHWAYS

FORSYTH COUNTY

LOCATION: WINSTON - SALEM NORTHERN BELTWAY (EASTERN SECTION)  
FROM US 311 TO US 158 (FUTURE I-74)

TYPE OF WORK: WIDENING, GRADING, PAVING, DRAINAGE, SIGNING, SIGNALS,  
ITS, CULVERTS AND STRUCTURES.

PLFI PLANS

STATE	N.C.	PROJECT NUMBER	U-2579C	DATE	1
PROJECT NAME	U-2579C				
DATE	34839.1.9				
DESIGNATION	PE				
	34839.2.6				
	N/A				
	34839.2.GV18				
	N/A				
	34839.2.16				
	N/A				
	34839.3.GV6				
	NHP-0918(062)				
	CONSTR.				

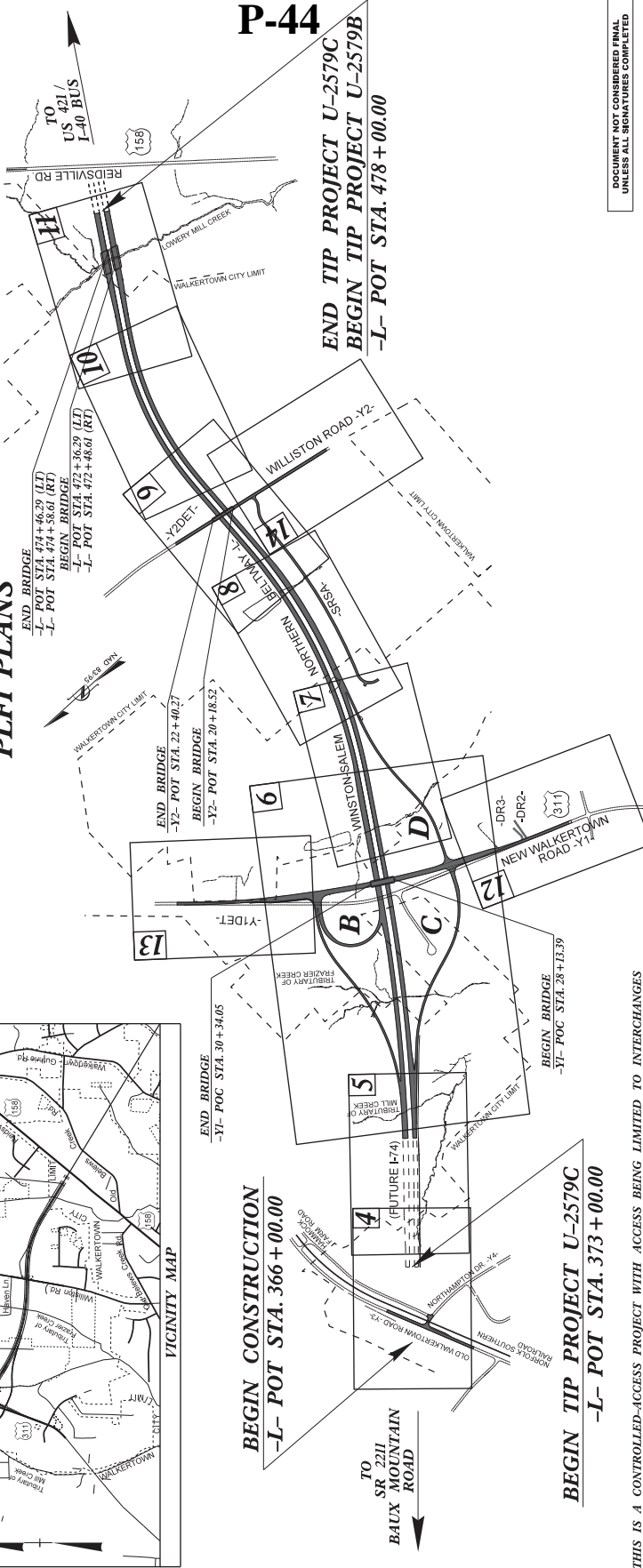

THIS IS A CONTROLLED-ACCESS PROJECT WITH ACCESS BEING LIMITED TO INTERCHANGES

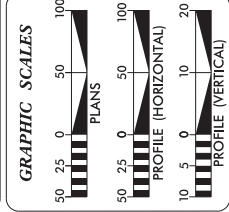

DESIGN DATA

ADT 2017	=	65,592
ADT 2037	=	93,112
DHV	=	10 %
D	=	60 %
T	=	18 % *
V	=	70 MPH

\* TTST 12 % DUAL 6 %

PROJECT LENGTH

LENGTH OF ROADWAY PROJECT U-2579C	=	1.989 Miles
LENGTH OF STRUCTURE PROJECT U-2579C	=	0.040 Mile
TOTAL LENGTH OF TIP PROJECT U-2579C	=	1.949 Miles

PLANS PREPARED BY: **RS&H** & ASSOCIATES, INC.

FOR THE NORTH CAROLINA DEPARTMENT OF TRANSPORTATION

8601 SIX FORKS RD. SUITE 200  
RALEIGH, NC 27612  
919-526-1100

RIGHT OF WAY DATE: OCTOBER 28, 2015

LETTING DATE: OCTOBER 17, 2017

JASON TALLEY, PE  
PROJECT ENGINEER

JARED BOND, PE  
PROJECT DESIGN ENGINEER

TATIA L. WHITE, PE, PLS  
NCDOT CONTACT

HYDRAULICS ENGINEER

ROADWAY DESIGN ENGINEER

DIVISION OF HIGHWAYS  
STATE OF NORTH CAROLINA

TIP PROJECT: U-2579C

CONTRACT:

PROJECT REFERENCE NO. U-2579C  
SHEET NO. 18

STATE OF NORTH CAROLINA, DIVISION OF HIGHWAYS  
CONVENTIONAL PLAN SHEET SYMBOLS  
\*S.U.E. = *Subsurface Utility Engineering*

**BOUNDARIES AND PROPERTY:**

State Line  
County Line  
Township Line  
City Line  
Reservation Line  
Property Line  
Existing Iron Pin  
Property Corner  
Property Monument  
Parcel/Sequence Number  
Existing Fence Line  
Proposed Woven Wire Fence  
Proposed Chain Link Fence  
Proposed Barbed Wire Fence  
Existing Wetland Boundary  
Proposed Wetland Boundary  
Existing Endangered Animal Boundary  
Existing Endangered Plant Boundary  
Existing Historic Property Boundary  
Known Contamination Area: Soil  
Potential Contamination Area: Soil  
Known Contamination Area: Water  
Potential Contamination Area: Water  
Contaminated Site: Known or Potential

**BUILDINGS AND OTHER CULTURE:**  
Gas Pump Vent or UG Tank Cap  
Sign  
Wall  
Small Mine  
Foundation  
Area Outline  
Cemetery  
Building  
School  
Church  
Dam

**HYDROLOGY:**  
Stream or Body of Water  
Hydro, Pool or Reservoir  
Jurisdictional Stream  
Buffer Zone 1  
Buffer Zone 2  
Flow Arrow  
Disappearing Stream  
Spring  
Wetland  
Proposed Lateral, Tail, Head Ditch  
False Sump

**RAILROADS:**

Standard Gauge  
RR Signal Milepost  
Switch  
RR Abandoned  
RR Dismantled

**RIGHT OF WAY:**

Baseline Control Point  
Existing Right of Way Marker  
Existing Right of Way Line  
Proposed Right of Way Line  
Proposed Right of Way Line with Iron Pin and Cap Marker  
Proposed Right of Way Line with Concrete or Granite RW Marker  
Proposed Control of Access Line with Concrete CA Marker  
Existing Control of Access  
Proposed Control of Access  
Existing Easement Line  
Proposed Temporary Construction Easement  
Proposed Temporary Drainage Easement  
Proposed Permanent Drainage Easement  
Proposed Permanent Drainage / Utility Easement  
Proposed Permanent Utility Easement  
Proposed Temporary Utility Easement  
Proposed Aerial Utility Easement  
Proposed Permanent Easement with Iron Pin and Cap Marker

**ROADS AND RELATED FEATURES:**  
Existing Curb  
Proposed Slope Stakes Cut  
Proposed Slope Stakes Fill  
Proposed Curb Ramp  
Existing Metal Guardrail  
Proposed Guardrail  
Existing Cable Guide rail  
Proposed Cable Guide rail  
Equality Symbol  
Pavement Removal

**VEGETATION:**

Single Tree  
Single Shrub  
Hedge  
Woods Line

**WATER:**

Water Manhole  
Water Meter  
Water Valve  
Water Hydrant  
UG Water Line LOS B (S.U.E.)  
UG Water Line LOS C (S.U.E.)  
UG Water Line LOS D (S.U.E.)  
Above Ground Water Line

**TV:**

TV Pedestal  
TV Tower  
UG TV Cable Hand Hole  
UG TV Cable LOS B (S.U.E.)  
UG TV Cable LOS C (S.U.E.)  
UG TV Cable LOS D (S.U.E.)  
UG Fiber Optic Cable LOS B (S.U.E.)  
UG Fiber Optic Cable LOS C (S.U.E.)  
UG Fiber Optic Cable LOS D (S.U.E.)

**GAS:**

Gas Valve  
Gas Meter  
UG Gas Line LOS B (S.U.E.)  
UG Gas Line LOS C (S.U.E.)  
UG Gas Line LOS D (S.U.E.)  
Above Ground Gas Line

**SANITARY SEWER:**

Sanitary Sewer Manhole  
Sanitary Sewer Cleanout  
UG Sanitary Sewer Line  
Above Ground Sanitary Sewer  
SS Forced Main Line LOS B (S.U.E.)  
SS Forced Main Line LOS C (S.U.E.)  
SS Forced Main Line LOS D (S.U.E.)

**MISCELLANEOUS:**

Utility Pole  
Utility Pole with Base  
Utility Located Object  
Utility Traffic Signal Box  
Utility Unknown UG Line LOS B (S.U.E.)  
UG Tank; Water, Gas, Oil  
Underground Storage Tank, Approx. Loc.  
AG Tank; Water, Gas, Oil  
Geoenvironmental Boring  
UG Test Hole LOS A (S.U.E.)  
Abandoned According to Utility Records  
End of Information

# SURVEY CONTROL SHEET U-2579C

PROJECT REFERENCE NO. U-2579C  
SHEET NO. 10-A  
Location and Surveys

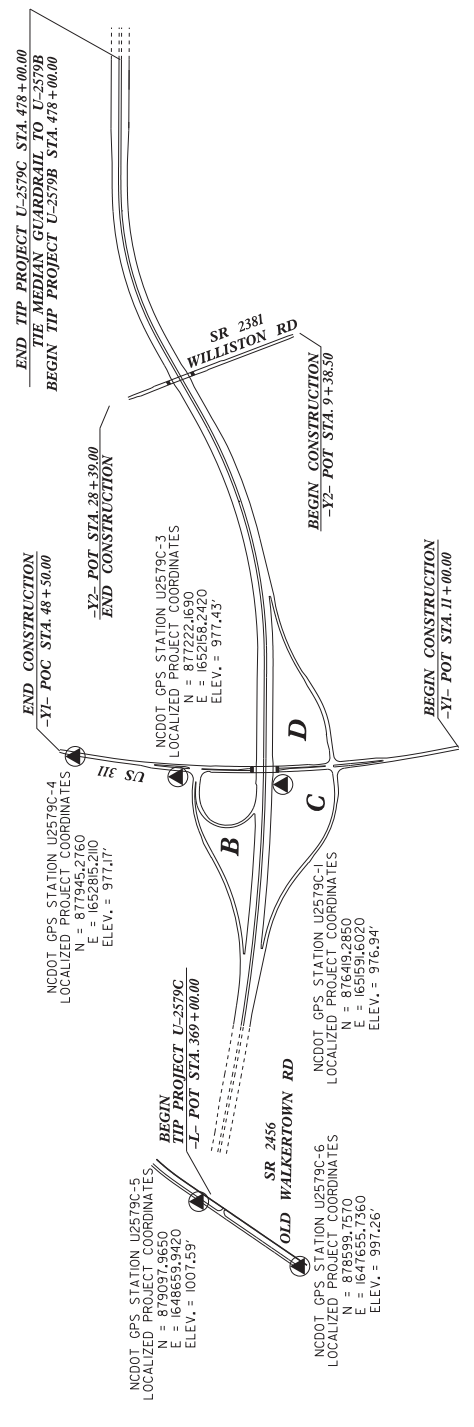
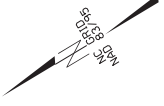
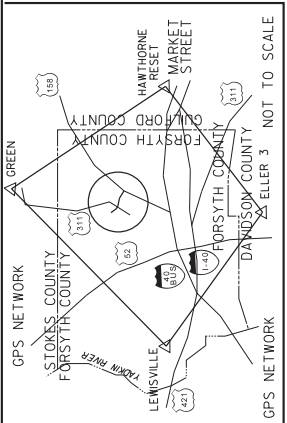

### DATUM DESCRIPTION

THE LOCALIZED COORDINATE SYSTEM DEVELOPED FOR THIS PROJECT IS BASED ON THE STATE PLANE COORDINATES ESTABLISHED BY NCOS FOR MONUMENT "U2579C-1" WITH MAD 83/95 STATE PLANE GRID COORDINATES OF NORTHING: 876419.285 (ft) EASTING: 165191.602 (ft) ELEVATION: 976.94 (ft)

THE AVERAGE COMBINED GRID FACTOR USED ON THIS PROJECT (GROUND TO GRID) IS: 0.99995453

THE N.C. LAMBERT GRID BEARING AND LOCALIZED HORIZONTAL GROUND DISTANCE FROM "U2579C-1" TO L- STATION 390+00.00 IS  
N 49°00'53.54" 3884.0262'

ALL LINEAR DIMENSIONS ARE LOCALIZED HORIZONTAL DISTANCES VERTICAL DATUM USED IS NAVD 88

- NOTES:**
1. THE SITE CALIBRATION SHOWN IS BASED UPON A NETWORK TIED TO THE BARN (HIGH ACCURACY REFERENCE NETWORK) AND 89% ADJUSTMENT. THIS CALIBRATION WILL ALLOW THE END USER TO WORK WITHIN THE SAME COORDINATE SYSTEM WHEN USING ITRK (REAL TIME KINEMATICS) AND A LOCAL BASE STATION. IF ANOTHER LOCALIZATION METHOD IS USED, ADDITIONAL FIELD TIES MAY BE NEEDED TO REDUCE POSSIBLE ERRORS OR BIASES.
  2. THE CONTROL DATA FOR THIS PROJECT CAN BE FOUND ELECTRONICALLY BY SELECTING PROJECT CONTROL DATA AT:  
[HTTPS://CONNECT.NCDOT.GOV/RESOURCES/LOCATION](https://connect.ncdot.gov/resources/location)  
THE FILES TO BE FOUND ARE AS FOLLOWS:  
U2579C\_L1S\_GPSCALIBR.ITML  
U2579C\_L1S\_WGS84.TXT  
U2579C\_L1S\_LOCAL.TXT  
U2579C\_L1S\_CONTROL.TXT
- THE WGS84 AND LOCAL FILES ARE COMMA DELIMITED AND CAN BE USED TO REPRODUCE THE SITE CALIBRATION FOR THE END USER'S GPS EQUIPMENT IF FURTHER INFORMATION IS NEEDED. PLEASE CONTACT THE LOCATION AND SURVEYS UNIT.
- FORWARDERS, CONTRACTORS, MANAGERS, USED OR SET FOR HORIZONTAL PROJECT CONTROL NETWORK CONTROL ESTABLISHED FROM EXISTING BARN MONUMENTATION SYSTEM. BY THE NCDOT LOCATION AND SURVEYS UNIT.
- SEE GPS CALIBRATION SHEET FOR HORIZONTAL AND VERTICAL COORDINATE VALUES.

NOTE: DRAWING NOT TO SCALE

15-FAR-2017-840 U2579C L1-L1-1d9g 15-FAR-2017-840





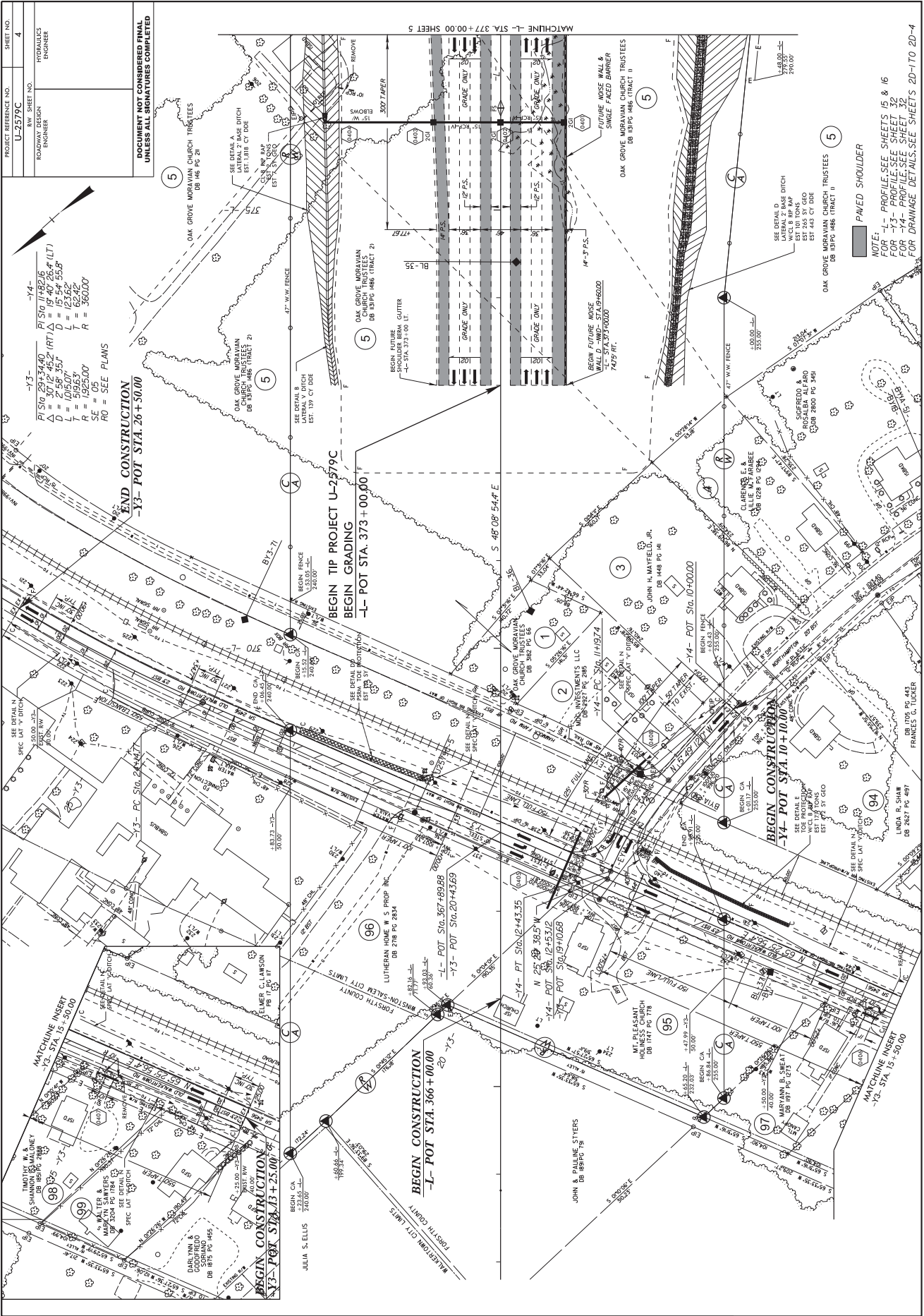

PROJECT REFERENCE NO.	U-2579C	SHEET NO.	4
R/W SHEET NO.			
ROADWAY DESIGN ENGINEER			
HYDRAULICS ENGINEER			

DOCUMENT NOT CONSIDERED FINAL UNLESS ALL SIGNATURES COMPLETED

$P/Sig: 29.3/4.40$   $P/Sig: 11/42.16$   
 $\Delta = 30.12/45.2$   $(RT \Delta) = 19.40/26.6$   $(LT)$   
 $D = 10.60/7.57$   $D = 12.52/5.55$   
 $T = 5.93/6.57$   $T = 6.62/4.2$   
 $R = 1.92/5.00$   $R = 3.60/2.00$   
 $SE = 05$   
 $HO = SEE PLANS$

**END CONSTRUCTION**  
 -Y3- POT STA. 26+50.00

**BEGIN TIP PROJECT U-2579C**  
**BEGIN GRADING**  
 -L- POT STA. 373+00.00

**BEGIN CONSTRUCTION**  
 -L- POT STA. 366+00.00

**BEGIN CONSTRUCTION**  
 -Y3- POT STA. 43+25.00

**BEGIN CONSTRUCTION**  
 -Y4- POT STA. 10+10.00

**BEGIN CONSTRUCTION**  
 -Y4- POT STA. 14+50.00

**BEGIN CONSTRUCTION**  
 -Y2- STA. 15+50.00

**BEGIN CONSTRUCTION**  
 -Y3- POT STA. 25.00

**BEGIN CONSTRUCTION**  
 -Y3- POT STA. 25.00

**BEGIN CONSTRUCTION**  
 -Y3- POT STA. 25.00

OAK GROVE MORAVIAN CHURCH TRUSTEES  
 DB 146 PG 21

OAK GROVE MORAVIAN CHURCH TRUSTEES  
 DB 146 PG 21

OAK GROVE MORAVIAN CHURCH TRUSTEES  
 DB 146 PG 21

OAK GROVE MORAVIAN CHURCH TRUSTEES  
 DB 146 PG 21

OAK GROVE MORAVIAN CHURCH TRUSTEES  
 DB 146 PG 21

OAK GROVE MORAVIAN CHURCH TRUSTEES  
 DB 146 PG 21

OAK GROVE MORAVIAN CHURCH TRUSTEES  
 DB 146 PG 21

OAK GROVE MORAVIAN CHURCH TRUSTEES  
 DB 146 PG 21

OAK GROVE MORAVIAN CHURCH TRUSTEES  
 DB 146 PG 21

OAK GROVE MORAVIAN CHURCH TRUSTEES  
 DB 146 PG 21

OAK GROVE MORAVIAN CHURCH TRUSTEES  
 DB 146 PG 21

OAK GROVE MORAVIAN CHURCH TRUSTEES  
 DB 146 PG 21

OAK GROVE MORAVIAN CHURCH TRUSTEES  
 DB 146 PG 21

OAK GROVE MORAVIAN CHURCH TRUSTEES  
 DB 146 PG 21

OAK GROVE MORAVIAN CHURCH TRUSTEES  
 DB 146 PG 21

OAK GROVE MORAVIAN CHURCH TRUSTEES  
 DB 146 PG 21

OAK GROVE MORAVIAN CHURCH TRUSTEES  
 DB 146 PG 21

OAK GROVE MORAVIAN CHURCH TRUSTEES  
 DB 146 PG 21

OAK GROVE MORAVIAN CHURCH TRUSTEES  
 DB 146 PG 21

OAK GROVE MORAVIAN CHURCH TRUSTEES  
 DB 146 PG 21

OAK GROVE MORAVIAN CHURCH TRUSTEES  
 DB 146 PG 21

OAK GROVE MORAVIAN CHURCH TRUSTEES  
 DB 146 PG 21

OAK GROVE MORAVIAN CHURCH TRUSTEES  
 DB 146 PG 21

OAK GROVE MORAVIAN CHURCH TRUSTEES  
 DB 146 PG 21

OAK GROVE MORAVIAN CHURCH TRUSTEES  
 DB 146 PG 21

OAK GROVE MORAVIAN CHURCH TRUSTEES  
 DB 146 PG 21

OAK GROVE MORAVIAN CHURCH TRUSTEES  
 DB 146 PG 21

OAK GROVE MORAVIAN CHURCH TRUSTEES  
 DB 146 PG 21

OAK GROVE MORAVIAN CHURCH TRUSTEES  
 DB 146 PG 21

OAK GROVE MORAVIAN CHURCH TRUSTEES  
 DB 146 PG 21

OAK GROVE MORAVIAN CHURCH TRUSTEES  
 DB 146 PG 21

OAK GROVE MORAVIAN CHURCH TRUSTEES  
 DB 146 PG 21

OAK GROVE MORAVIAN CHURCH TRUSTEES  
 DB 146 PG 21

OAK GROVE MORAVIAN CHURCH TRUSTEES  
 DB 146 PG 21

OAK GROVE MORAVIAN CHURCH TRUSTEES  
 DB 146 PG 21

OAK GROVE MORAVIAN CHURCH TRUSTEES  
 DB 146 PG 21

OAK GROVE MORAVIAN CHURCH TRUSTEES  
 DB 146 PG 21

OAK GROVE MORAVIAN CHURCH TRUSTEES  
 DB 146 PG 21

OAK GROVE MORAVIAN CHURCH TRUSTEES  
 DB 146 PG 21

OAK GROVE MORAVIAN CHURCH TRUSTEES  
 DB 146 PG 21

OAK GROVE MORAVIAN CHURCH TRUSTEES  
 DB 146 PG 21

OAK GROVE MORAVIAN CHURCH TRUSTEES  
 DB 146 PG 21

OAK GROVE MORAVIAN CHURCH TRUSTEES  
 DB 146 PG 21

OAK GROVE MORAVIAN CHURCH TRUSTEES  
 DB 146 PG 21

OAK GROVE MORAVIAN CHURCH TRUSTEES  
 DB 146 PG 21

OAK GROVE MORAVIAN CHURCH TRUSTEES  
 DB 146 PG 21

OAK GROVE MORAVIAN CHURCH TRUSTEES  
 DB 146 PG 21

OAK GROVE MORAVIAN CHURCH TRUSTEES  
 DB 146 PG 21

OAK GROVE MORAVIAN CHURCH TRUSTEES  
 DB 146 PG 21

OAK GROVE MORAVIAN CHURCH TRUSTEES  
 DB 146 PG 21

OAK GROVE MORAVIAN CHURCH TRUSTEES  
 DB 146 PG 21

OAK GROVE MORAVIAN CHURCH TRUSTEES  
 DB 146 PG 21

OAK GROVE MORAVIAN CHURCH TRUSTEES  
 DB 146 PG 21

OAK GROVE MORAVIAN CHURCH TRUSTEES  
 DB 146 PG 21

OAK GROVE MORAVIAN CHURCH TRUSTEES  
 DB 146 PG 21

OAK GROVE MORAVIAN CHURCH TRUSTEES  
 DB 146 PG 21

OAK GROVE MORAVIAN CHURCH TRUSTEES  
 DB 146 PG 21

OAK GROVE MORAVIAN CHURCH TRUSTEES  
 DB 146 PG 21

OAK GROVE MORAVIAN CHURCH TRUSTEES  
 DB 146 PG 21

OAK GROVE MORAVIAN CHURCH TRUSTEES  
 DB 146 PG 21

OAK GROVE MORAVIAN CHURCH TRUSTEES  
 DB 146 PG 21

OAK GROVE MORAVIAN CHURCH TRUSTEES  
 DB 146 PG 21

OAK GROVE MORAVIAN CHURCH TRUSTEES  
 DB 146 PG 21

OAK GROVE MORAVIAN CHURCH TRUSTEES  
 DB 146 PG 21

OAK GROVE MORAVIAN CHURCH TRUSTEES  
 DB 146 PG 21

OAK GROVE MORAVIAN CHURCH TRUSTEES  
 DB 146 PG 21

OAK GROVE MORAVIAN CHURCH TRUSTEES  
 DB 146 PG 21

OAK GROVE MORAVIAN CHURCH TRUSTEES  
 DB 146 PG 21

OAK GROVE MORAVIAN CHURCH TRUSTEES  
 DB 146 PG 21

OAK GROVE MORAVIAN CHURCH TRUSTEES  
 DB 146 PG 21

OAK GROVE MORAVIAN CHURCH TRUSTEES  
 DB 146 PG 21

OAK GROVE MORAVIAN CHURCH TRUSTEES  
 DB 146 PG 21

OAK GROVE MORAVIAN CHURCH TRUSTEES  
 DB 146 PG 21

OAK GROVE MORAVIAN CHURCH TRUSTEES  
 DB 146 PG 21

OAK GROVE MORAVIAN CHURCH TRUSTEES  
 DB 146 PG 21

OAK GROVE MORAVIAN CHURCH TRUSTEES  
 DB 146 PG 21

OAK GROVE MORAVIAN CHURCH TRUSTEES  
 DB 146 PG 21

RIGHT OF WAY REVISION 7/26/16 - COMBINED PARCELS 5, 6, 7 & 8 AS ONE PARCEL 5 AND CHANGED PROPERTY OWNER NAMES TO TRUSTEES OF OAK GROVE MORAVIAN CHURCH  
 DB 143 PG 486 AND THE BOARD OF PROPERTY OWNERS OF THE MORAVIAN CHURCH DB 146 PG 214, 215, 216, 217, 218, 219, 220, 221, 222, 223, 224, 225, 226, 227, 228, 229, 230, 231, 232, 233, 234, 235, 236, 237, 238, 239, 240, 241, 242, 243, 244, 245, 246, 247, 248, 249, 250, 251, 252, 253, 254, 255, 256, 257, 258, 259, 260, 261, 262, 263, 264, 265, 266, 267, 268, 269, 270, 271, 272, 273, 274, 275, 276, 277, 278, 279, 280, 281, 282, 283, 284, 285, 286, 287, 288, 289, 290, 291, 292, 293, 294, 295, 296, 297, 298, 299, 300, 301, 302, 303, 304, 305, 306, 307, 308, 309, 310, 311, 312, 313, 314, 315, 316, 317, 318, 319, 320, 321, 322, 323, 324, 325, 326, 327, 328, 329, 330, 331, 332, 333, 334, 335, 336, 337, 338, 339, 340, 341, 342, 343, 344, 345, 346, 347, 348, 349, 350, 351, 352, 353, 354, 355, 356, 357, 358, 359, 360, 361, 362, 363, 364, 365, 366, 367, 368, 369, 370, 371, 372, 373, 374, 375, 376, 377, 378, 379, 380, 381, 382, 383, 384, 385, 386, 387, 388, 389, 390, 391, 392, 393, 394, 395, 396, 397, 398, 399, 400, 401, 402, 403, 404, 405, 406, 407, 408, 409, 410, 411, 412, 413, 414, 415, 416, 417, 418, 419, 420, 421, 422, 423, 424, 425, 426, 427, 428, 429, 430, 431, 432, 433, 434, 435, 436, 437, 438, 439, 440, 441, 442, 443, 444, 445, 446, 447, 448, 449, 450, 451, 452, 453, 454, 455, 456, 457, 458, 459, 460, 461, 462, 463, 464, 465, 466, 467, 468, 469, 470, 471, 472, 473, 474, 475, 476, 477, 478, 479, 480, 481, 482, 483, 484, 485, 486, 487, 488, 489, 490, 491, 492, 493, 494, 495, 496, 497, 498, 499, 500, 501, 502, 503, 504, 505, 506, 507, 508, 509, 510, 511, 512, 513, 514, 515, 516, 517, 518, 519, 520, 521, 522, 523, 524, 525, 526, 527, 528, 529, 530, 531, 532, 533, 534, 535, 536, 537, 538, 539, 540, 541, 542, 543, 544, 545, 546, 547, 548, 549, 550, 551, 552, 553, 554, 555, 556, 557, 558, 559, 560, 561, 562, 563, 564, 565, 566, 567, 568, 569, 570, 571, 572, 573, 574, 575, 576, 577, 578, 579, 580, 581, 582, 583, 584, 585, 586, 587, 588, 589, 590, 591, 592, 593, 594, 595, 596, 597, 598, 599, 600, 601, 602, 603, 604, 605, 606, 607, 608, 609, 610, 611, 612, 613, 614, 615, 616, 617, 618, 619, 620, 621, 622, 623, 624, 625, 626, 627, 628, 629, 630, 631, 632, 633, 634, 635, 636, 637, 638, 639, 640, 641, 642, 643, 644, 645, 646, 647, 648, 649, 650, 651, 652, 653, 654, 655, 656, 657, 658, 659, 660, 661, 662, 663, 664, 665, 666, 667, 668, 669, 670, 671, 672, 673, 674, 675, 676, 677, 678, 679, 680, 681, 682, 683, 684, 685, 686, 687, 688, 689, 690, 691, 692, 693, 694, 695, 696, 697, 698, 699, 700, 701, 702, 703, 704, 705, 706, 707, 708, 709, 710, 711, 712, 713, 714, 715, 716, 717, 718, 719, 720, 721, 722, 723, 724, 725, 726, 727, 728, 729, 730, 731, 732, 733, 734, 735, 736, 737, 738, 739, 740, 741, 742, 743, 744, 745, 746, 747, 748, 749, 750, 751, 752, 753, 754, 755, 756, 757, 758, 759, 760, 761, 762, 763, 764, 765, 766, 767, 768, 769, 770, 771, 772, 773, 774, 775, 776, 777, 778, 779, 780, 781, 782, 783, 784, 785, 786, 787, 788, 789, 790, 791, 792, 793, 794, 795, 796, 797, 798, 799, 800, 801, 802, 803, 804, 805, 806, 807, 808, 809, 810, 811, 812, 813, 814, 815, 816, 817, 818, 819, 820, 821, 822, 823, 824, 825, 826, 827, 828, 829, 830, 831, 832, 833, 834, 835, 836, 837, 838, 839, 840, 841, 842, 843, 844, 845, 846, 847, 848, 849, 850, 851, 852, 853, 854, 855, 856, 857, 858, 859, 860, 861, 862, 863, 864, 865, 866, 867, 868, 869, 870, 871, 872, 873, 874, 875, 876, 877, 878, 879, 880, 881, 882, 883, 884, 885, 886, 887, 888, 889, 890, 891, 892, 893, 894, 895, 896, 897, 898, 899, 900, 901, 902, 903, 904, 905, 906, 907, 908, 909, 910, 911, 912, 913, 914, 915, 916, 917, 918, 919, 920, 921, 922, 923, 924, 925, 926, 927, 928, 929, 930, 931, 932, 933, 934, 935, 936, 937, 938, 939, 940, 941, 942, 943, 944, 945, 946, 947, 948, 949, 950, 951, 952, 953, 954, 955, 956, 957, 958, 959, 960, 961, 962, 963, 964, 965, 966, 967, 968, 969, 970, 971, 972, 973, 974, 975, 976, 977, 978, 979, 980, 981, 982, 983, 984, 985, 986, 987, 988, 989, 990, 991, 992, 993, 994, 995, 996, 997, 998, 999, 1000.

B/17/94

24-MAR-2017 10:28 U:\2579C\psh\_4.dgn

REVISIONS

# P-49

PROJECT REFERENCE NO.	U-2579C
R/W SHEET NO.	5
DESIGNER	HYDRAULICS ENGINEERS
ENGINEER	

DOCUMENT NOT CONSIDERED FINAL UNLESS ALL SIGNATURES COMPLETED

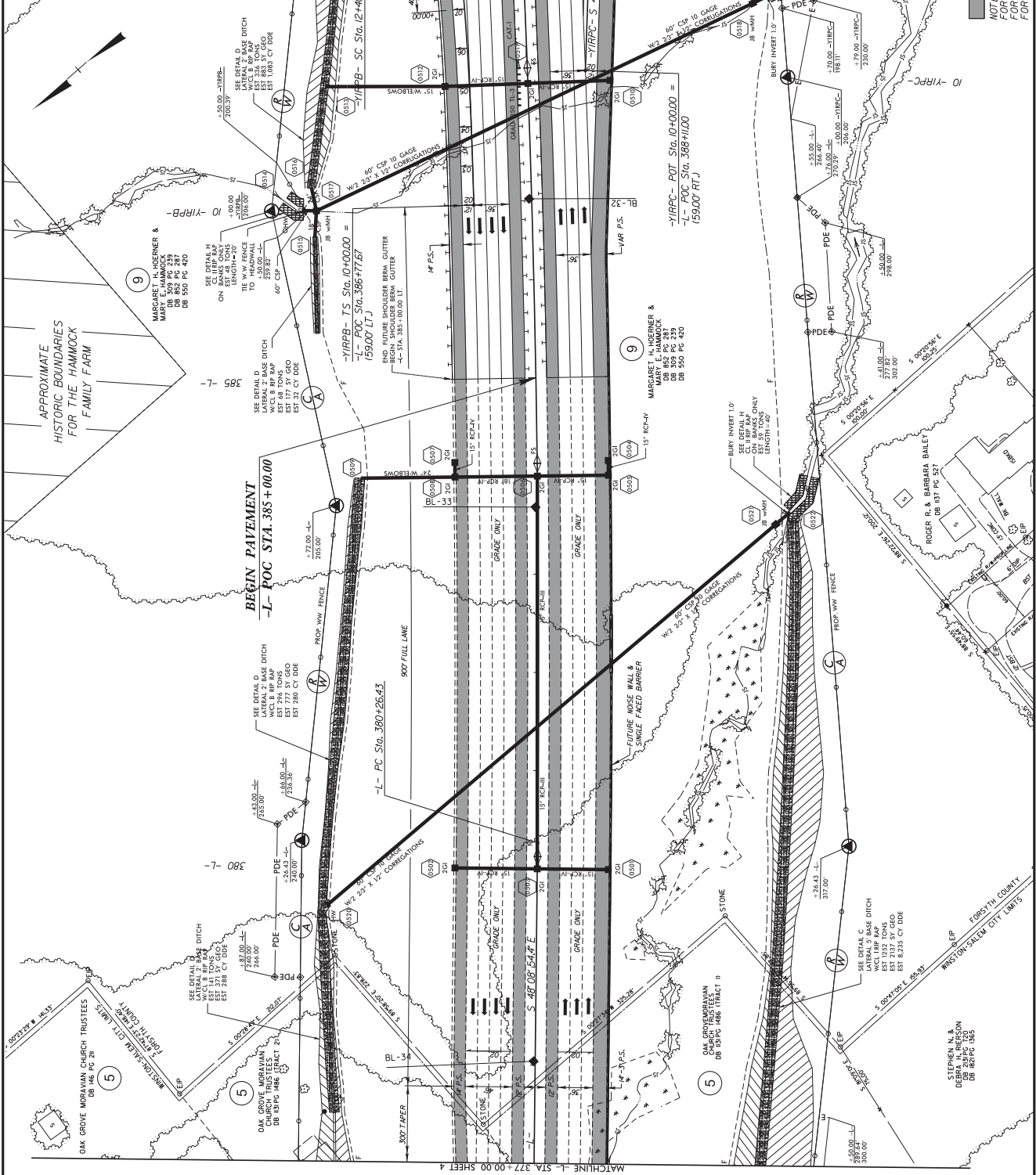

NOTE:  
 FOR -L- PROFILE SEE SHEETS 16 & 17  
 FOR -YIRPB- PROFILE SEE SHEET 24  
 FOR -YIRPC- PROFILE SEE SHEET 25

RIGHT OF WAY REVISION 7/28/16 - COMBINED PARCELS 5/2, 7 & 8 AS ONE PARCEL 5 AND CHANGED PROPERTY OWNER NAMES TO TRUSTEES OF OAK GROVE MORAVIAN CHURCH DB 151 PG 485 AND 486 PG 201, 202, 203, 204, 205, 206, 207, 208, 209, 210, 211, 212, 213, 214, 215, 216, 217, 218, 219, 220, 221, 222, 223, 224, 225, 226, 227, 228, 229, 230, 231, 232, 233, 234, 235, 236, 237, 238, 239, 240, 241, 242, 243, 244, 245, 246, 247, 248, 249, 250, 251, 252, 253, 254, 255, 256, 257, 258, 259, 260, 261, 262, 263, 264, 265, 266, 267, 268, 269, 270, 271, 272, 273, 274, 275, 276, 277, 278, 279, 280, 281, 282, 283, 284, 285, 286, 287, 288, 289, 290, 291, 292, 293, 294, 295, 296, 297, 298, 299, 300, 301, 302, 303, 304, 305, 306, 307, 308, 309, 310, 311, 312, 313, 314, 315, 316, 317, 318, 319, 320, 321, 322, 323, 324, 325, 326, 327, 328, 329, 330, 331, 332, 333, 334, 335, 336, 337, 338, 339, 340, 341, 342, 343, 344, 345, 346, 347, 348, 349, 350, 351, 352, 353, 354, 355, 356, 357, 358, 359, 360, 361, 362, 363, 364, 365, 366, 367, 368, 369, 370, 371, 372, 373, 374, 375, 376, 377, 378, 379, 380, 381, 382, 383, 384, 385, 386, 387, 388, 389, 390, 391, 392, 393, 394, 395, 396, 397, 398, 399, 400, 401, 402, 403, 404, 405, 406, 407, 408, 409, 410, 411, 412, 413, 414, 415, 416, 417, 418, 419, 420, 421, 422, 423, 424, 425, 426, 427, 428, 429, 430, 431, 432, 433, 434, 435, 436, 437, 438, 439, 440, 441, 442, 443, 444, 445, 446, 447, 448, 449, 450, 451, 452, 453, 454, 455, 456, 457, 458, 459, 460, 461, 462, 463, 464, 465, 466, 467, 468, 469, 470, 471, 472, 473, 474, 475, 476, 477, 478, 479, 480, 481, 482, 483, 484, 485, 486, 487, 488, 489, 490, 491, 492, 493, 494, 495, 496, 497, 498, 499, 500, 501, 502, 503, 504, 505, 506, 507, 508, 509, 510, 511, 512, 513, 514, 515, 516, 517, 518, 519, 520, 521, 522, 523, 524, 525, 526, 527, 528, 529, 530, 531, 532, 533, 534, 535, 536, 537, 538, 539, 540, 541, 542, 543, 544, 545, 546, 547, 548, 549, 550, 551, 552, 553, 554, 555, 556, 557, 558, 559, 560, 561, 562, 563, 564, 565, 566, 567, 568, 569, 570, 571, 572, 573, 574, 575, 576, 577, 578, 579, 580, 581, 582, 583, 584, 585, 586, 587, 588, 589, 590, 591, 592, 593, 594, 595, 596, 597, 598, 599, 600, 601, 602, 603, 604, 605, 606, 607, 608, 609, 610, 611, 612, 613, 614, 615, 616, 617, 618, 619, 620, 621, 622, 623, 624, 625, 626, 627, 628, 629, 630, 631, 632, 633, 634, 635, 636, 637, 638, 639, 640, 641, 642, 643, 644, 645, 646, 647, 648, 649, 650, 651, 652, 653, 654, 655, 656, 657, 658, 659, 660, 661, 662, 663, 664, 665, 666, 667, 668, 669, 670, 671, 672, 673, 674, 675, 676, 677, 678, 679, 680, 681, 682, 683, 684, 685, 686, 687, 688, 689, 690, 691, 692, 693, 694, 695, 696, 697, 698, 699, 700, 701, 702, 703, 704, 705, 706, 707, 708, 709, 710, 711, 712, 713, 714, 715, 716, 717, 718, 719, 720, 721, 722, 723, 724, 725, 726, 727, 728, 729, 730, 731, 732, 733, 734, 735, 736, 737, 738, 739, 740, 741, 742, 743, 744, 745, 746, 747, 748, 749, 750, 751, 752, 753, 754, 755, 756, 757, 758, 759, 760, 761, 762, 763, 764, 765, 766, 767, 768, 769, 770, 771, 772, 773, 774, 775, 776, 777, 778, 779, 780, 781, 782, 783, 784, 785, 786, 787, 788, 789, 790, 791, 792, 793, 794, 795, 796, 797, 798, 799, 800, 801, 802, 803, 804, 805, 806, 807, 808, 809, 810, 811, 812, 813, 814, 815, 816, 817, 818, 819, 820, 821, 822, 823, 824, 825, 826, 827, 828, 829, 830, 831, 832, 833, 834, 835, 836, 837, 838, 839, 840, 841, 842, 843, 844, 845, 846, 847, 848, 849, 850, 851, 852, 853, 854, 855, 856, 857, 858, 859, 860, 861, 862, 863, 864, 865, 866, 867, 868, 869, 870, 871, 872, 873, 874, 875, 876, 877, 878, 879, 880, 881, 882, 883, 884, 885, 886, 887, 888, 889, 890, 891, 892, 893, 894, 895, 896, 897, 898, 899, 900, 901, 902, 903, 904, 905, 906, 907, 908, 909, 910, 911, 912, 913, 914, 915, 916, 917, 918, 919, 920, 921, 922, 923, 924, 925, 926, 927, 928, 929, 930, 931, 932, 933, 934, 935, 936, 937, 938, 939, 940, 941, 942, 943, 944, 945, 946, 947, 948, 949, 950, 951, 952, 953, 954, 955, 956, 957, 958, 959, 960, 961, 962, 963, 964, 965, 966, 967, 968, 969, 970, 971, 972, 973, 974, 975, 976, 977, 978, 979, 980, 981, 982, 983, 984, 985, 986, 987, 988, 989, 990, 991, 992, 993, 994, 995, 996, 997, 998, 999, 1000

8/17/19

03-MAT-2017\_0938  
 151-2579C.psd.sldgn



PROJECT REFERENCE NO.	SHEET NO.
U-2579C	6
ROW SHEET NO.	
ROADWAY DESIGN ENGINEER	HYDRAULICS ENGINEER

DOCUMENT NOT CONSIDERED FINAL  
UNLESS ALL SIGNATURES COMPLETED

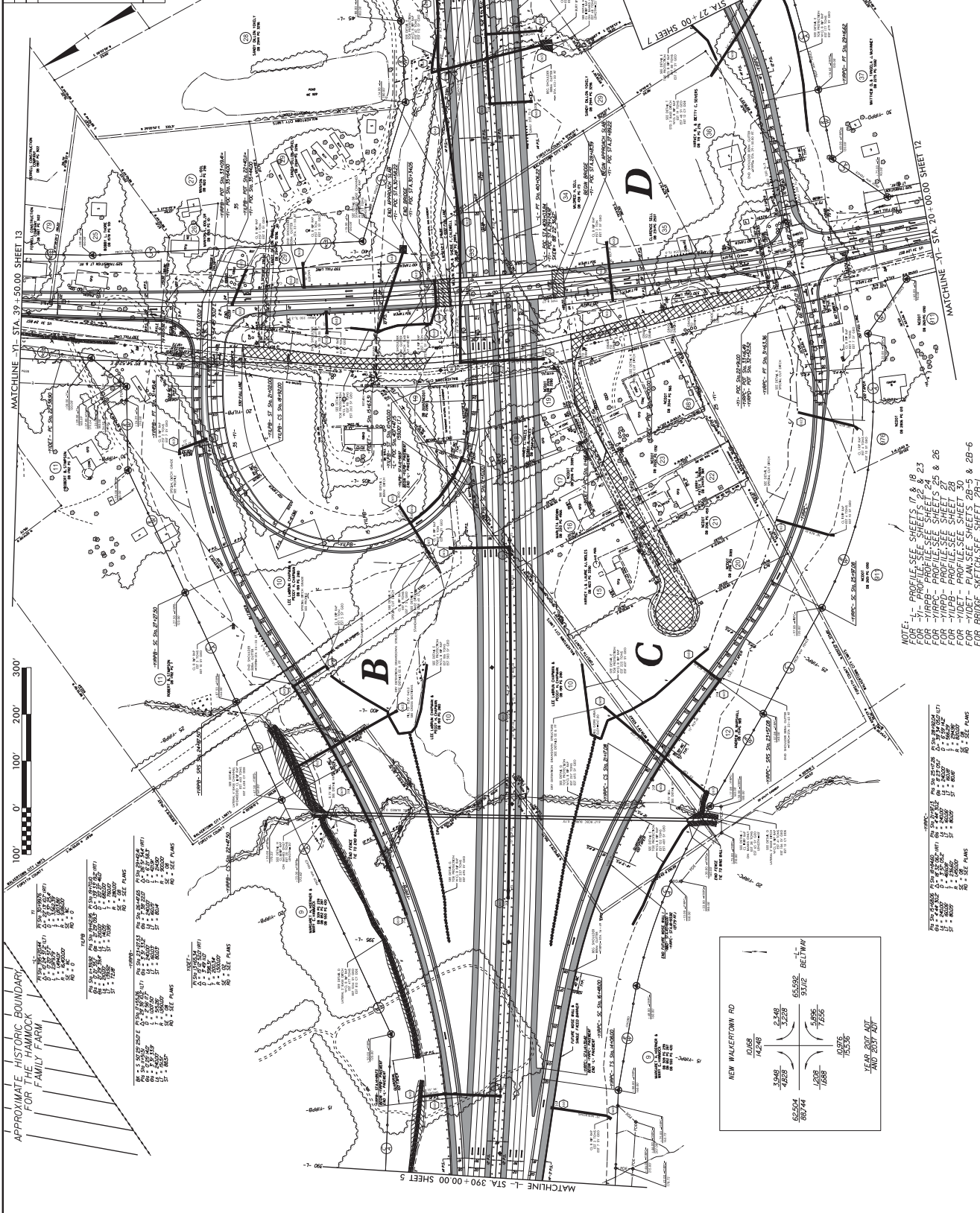

APPROXIMATE HISTORIC BOUNDARY  
FOR THE HAMMOCK  
FAMILY FARM

TABLE 1

NO.	DESCRIPTION	DATE	BY	CHKD.
1	ISSUED FOR PERMITS	08/17/2017	JMB	JMB
2	REVISED FOR PERMITS	08/17/2017	JMB	JMB
3	REVISED FOR PERMITS	08/17/2017	JMB	JMB
4	REVISED FOR PERMITS	08/17/2017	JMB	JMB
5	REVISED FOR PERMITS	08/17/2017	JMB	JMB
6	REVISED FOR PERMITS	08/17/2017	JMB	JMB
7	REVISED FOR PERMITS	08/17/2017	JMB	JMB
8	REVISED FOR PERMITS	08/17/2017	JMB	JMB
9	REVISED FOR PERMITS	08/17/2017	JMB	JMB
10	REVISED FOR PERMITS	08/17/2017	JMB	JMB

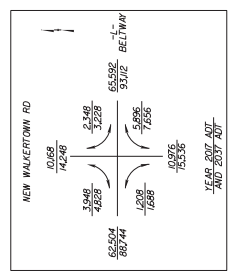

NOTE:  
FOR -L- PROFILE, SEE SHEETS 17 & 18  
FOR -TRAP- PROFILE, SEE SHEETS 22 & 23  
FOR -TRAP- PROFILE, SEE SHEETS 25 & 26  
FOR -TRAP- PROFILE, SEE SHEET 28  
FOR -TRAP- PROFILE, SEE SHEET 30  
FOR -TRAP- PROFILE, SEE SHEET 30  
FOR -TRAP- PROFILE, SEE SHEET 28-5 & 28-6  
FOR BRIDGE SKETCH, SEE SHEET 28-1

TABLE 2

NO.	DESCRIPTION	DATE	BY	CHKD.
1	ISSUED FOR PERMITS	08/17/2017	JMB	JMB
2	REVISED FOR PERMITS	08/17/2017	JMB	JMB
3	REVISED FOR PERMITS	08/17/2017	JMB	JMB
4	REVISED FOR PERMITS	08/17/2017	JMB	JMB
5	REVISED FOR PERMITS	08/17/2017	JMB	JMB
6	REVISED FOR PERMITS	08/17/2017	JMB	JMB
7	REVISED FOR PERMITS	08/17/2017	JMB	JMB
8	REVISED FOR PERMITS	08/17/2017	JMB	JMB
9	REVISED FOR PERMITS	08/17/2017	JMB	JMB
10	REVISED FOR PERMITS	08/17/2017	JMB	JMB

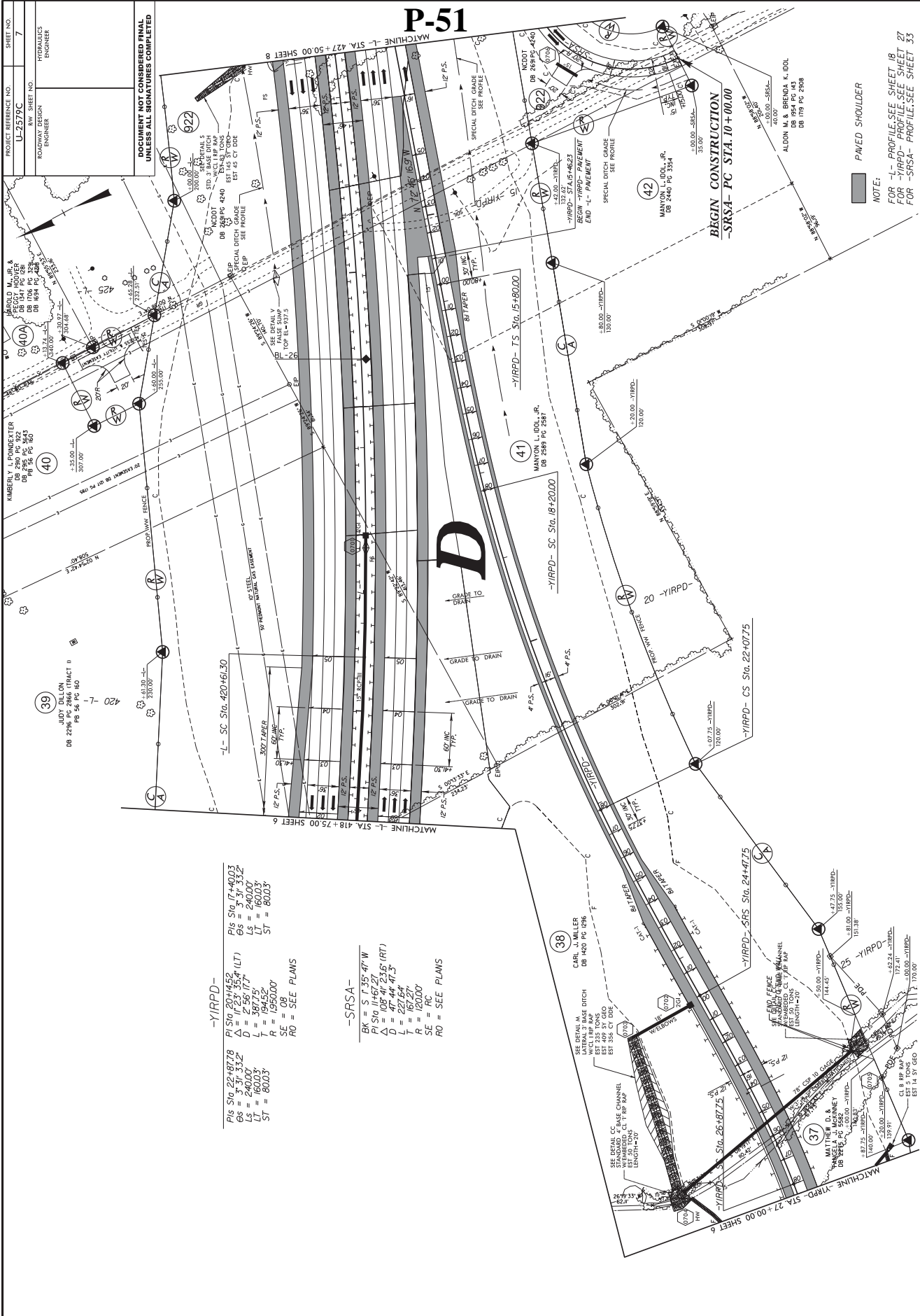

# P-51

PROJECT REFERENCE NO.	U-2579C
R/W SHEET NO.	7
DESIGNER	ROBERTSON ENGINEERS
ENGINEER	ROBERTSON ENGINEERS

DOCUMENT NOT CONSIDERED FINAL  
UNLESS ALL REVISIONS COMPLETED

**-YIRPD-**

PIS Sta. 22+87.78  
 Δ = 11° 23' 35.4" (LT)  
 OS = 240.00  
 L = 387.75'  
 P = 194.52'  
 T = 194.00'  
 ST = 800.03'  
 RO = SEE PLANS

**-SRSAs-**

BK = S 7.35° 47' W  
 P1 S10 81° 23.5' (RT)  
 D = 47° 44' 47.3"  
 L = 227.64'  
 P = 167.20'  
 T = 167.20'  
 ST = 800.03'  
 RO = SEE PLANS

NOTE:  
FOR L- PROFILE SEE SHEET 18  
FOR YIRPD- PROFILE SEE SHEET 27  
FOR SRSAs- PROFILE SEE SHEET 33

RIGHT OF WAY REVISION 3/7/17 - SHIFTED PROPERTY LINE BETWEEN PARCELS 39 AND 40/REMOVED PARCELS 39 AND 40/ADDED R/W ON PARCELS 42 AND 922.1MB  
 RIGHT OF WAY REVISION 5/3/17 - ADDED POE ON PARCEL 37/REVISED POE ON PARCEL 38/REVISED R/W ON PARCEL 40/ADDED R/W ON PARCELS 42 AND 922.1MB  
 REVISIONS  
 8/17/99





# P-53

PROJECT REFERENCE NO.	U-2579C
SHEET NO.	9
DESIGNER	ROBERTSON DESIGN ENGINEERS
ENGINEER	ROBERTSON DESIGN ENGINEERS

DOCUMENT NOT CONSIDERED FINAL  
UNLESS ALL SIGNATURES COMPLETED

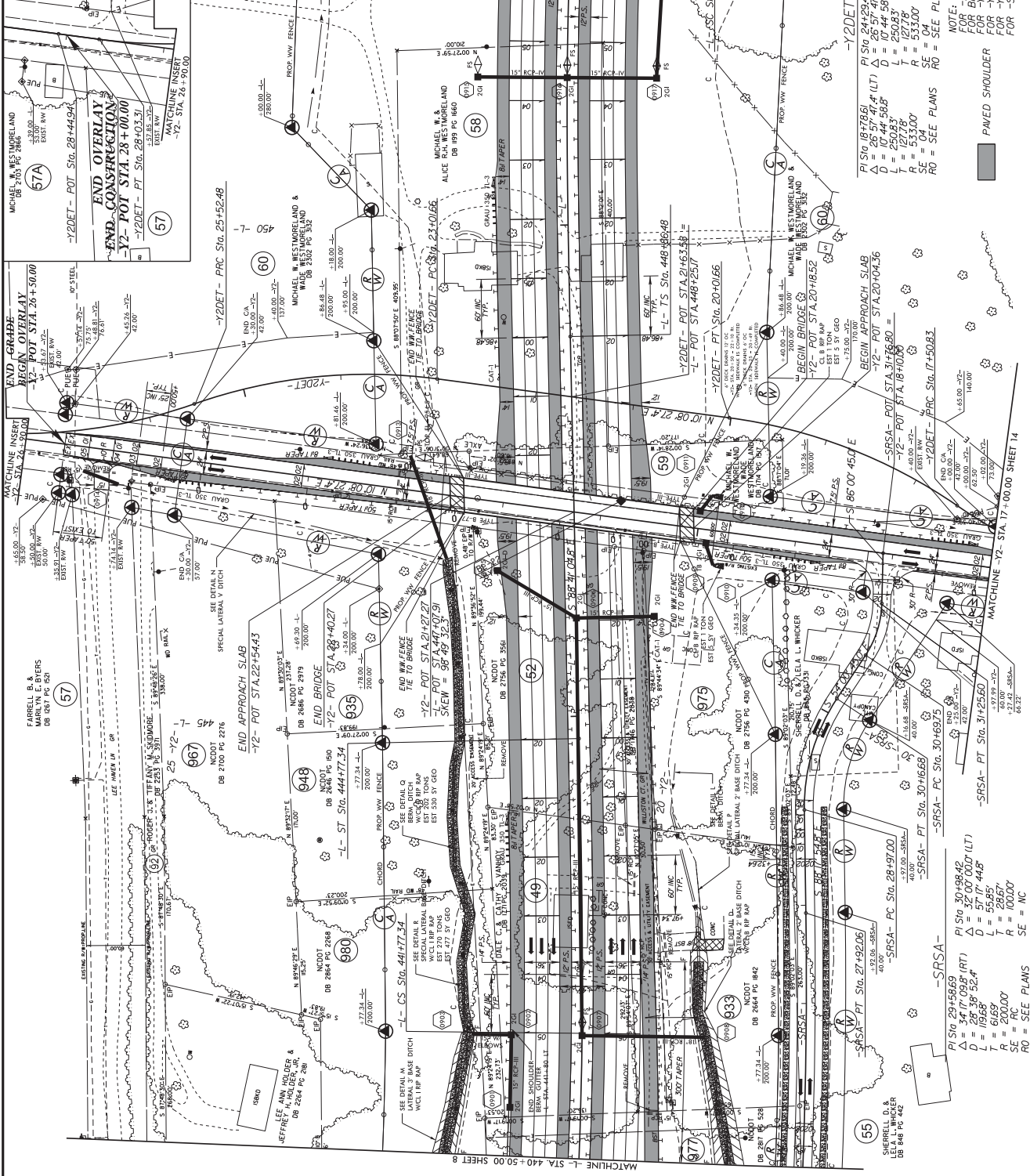

NOTE:

FOR PROFILE SEE SHEET 18 & 19	FOR BRIDGE PROFILE SEE SHEET 28-1
FOR SRS-A PROFILE SEE SHEET 28-1	FOR -Y2DET- PROFILE SEE SHEET 28-7
FOR -Y2DET- PROFILE SEE SHEET 31	FOR -SRS-A- PROFILE SEE SHEET 33

PI STA 18+78.61	PI STA 24+29.44	PI STA 26+80.26
Δ = 26.57' 47.4" (LT)	Δ = 26.57' 47.3" (LT)	Δ = 26.57' 47.3" (RT)
D = 90.98' 36.8"	D = 10.44' 59.8"	D = 90.98' 36.8"
L = 127.78'	L = 127.78'	L = 127.78'
T = 127.78'	T = 127.78'	T = 127.78'
R = 533.00'	R = 533.00'	R = 533.00'
SE = RC	SE = RC	SE = RC
RO = SEE PLANS	RO = SEE PLANS	RO = SEE PLANS

PAVED SHOULDER

RIGHT OF WAY REVISION 12/21/16 - ADDED PARCEL 057A (MICHAEL WESTMORELAND) ABOVE PROPERTY LINE OF PARCEL 57 (FERRELL) ON INSET. JMB  
 REVISION 5/21/17 - REWAS REFERENCE TO PARCEL 54 (DUNCAN) IN 5-A PARCEL OF PARCEL 55. ADDED R/W ON PARCELS 933, 975, AND 977.  
 REVISION R/W ON PARCEL 55. REMOVED PUE AND REVISED TCE ON PARCEL 55. ADDED TCE ON PARCEL 60. JMB  
 8/17/19





# P-55

PROJECT REFERENCE NO. <b>U-2579C</b>	SHEET NO. <b>11</b>
BY SHEET NO. <b>ROADWAY DESIGN ENGINEER</b>	HYDRAULICS ENGINEER

**DOCUMENT NOT CONSIDERED FINAL UNLESS ALL SIGNATURES COMPLETED**

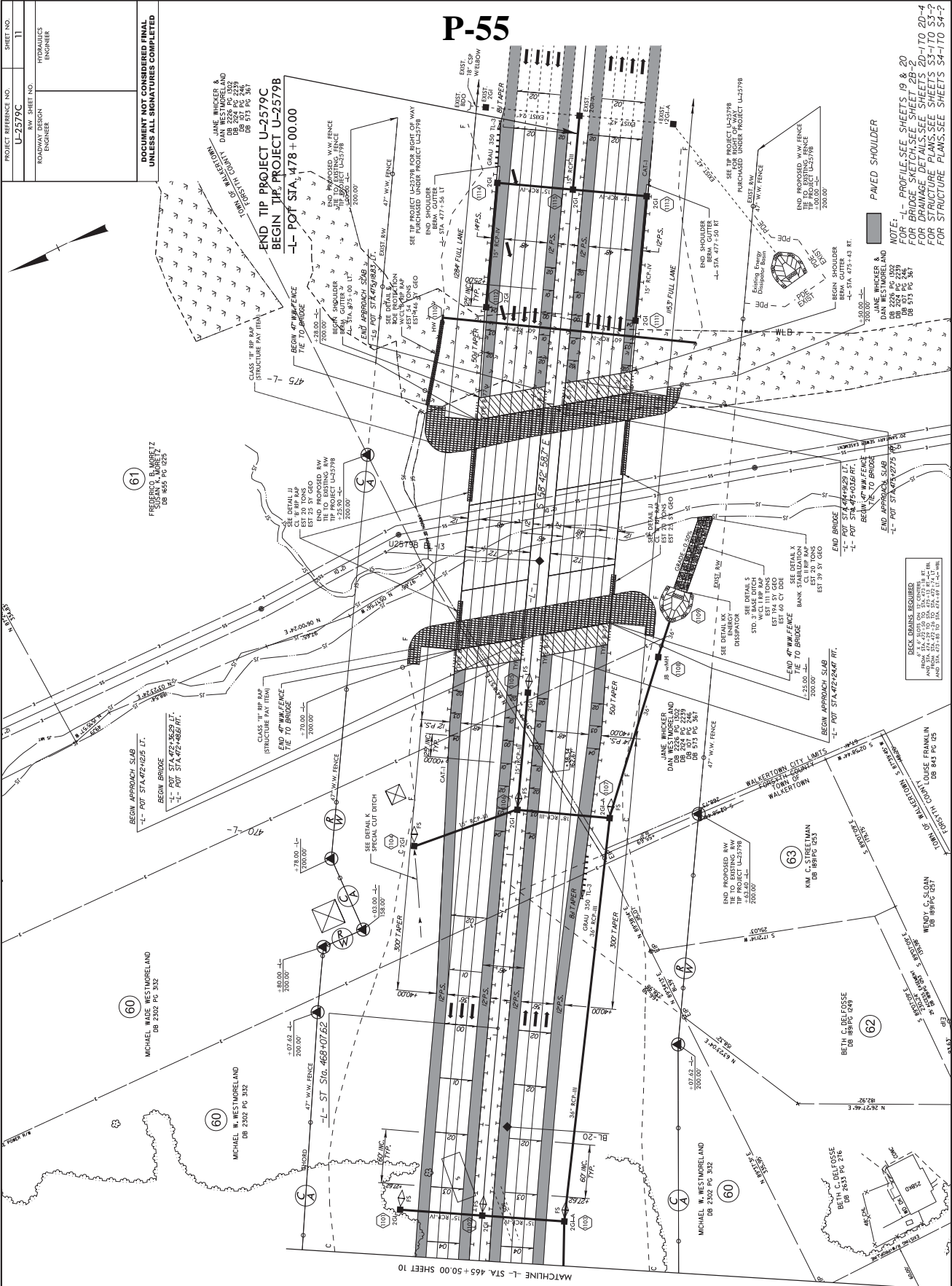

8/17/99

REVISIONS

2-MAY-2017 4:04 PM U-2579C.pht.ll.dwg  
 11/15/2017 10:11 AM U-2579C.pht.ll.dwg  
 11/15/2017 10:11 AM U-2579C.pht.ll.dwg

PROJECT REFERENCE NO.	U-2579C
SHEET NO.	12
ROW DESIGN ENGINEER	ROBERTS ENGINEERS
DOCUMENT NOT CONSIDERED FINAL UNLESS ALL SIGNATURES COMPLETED	

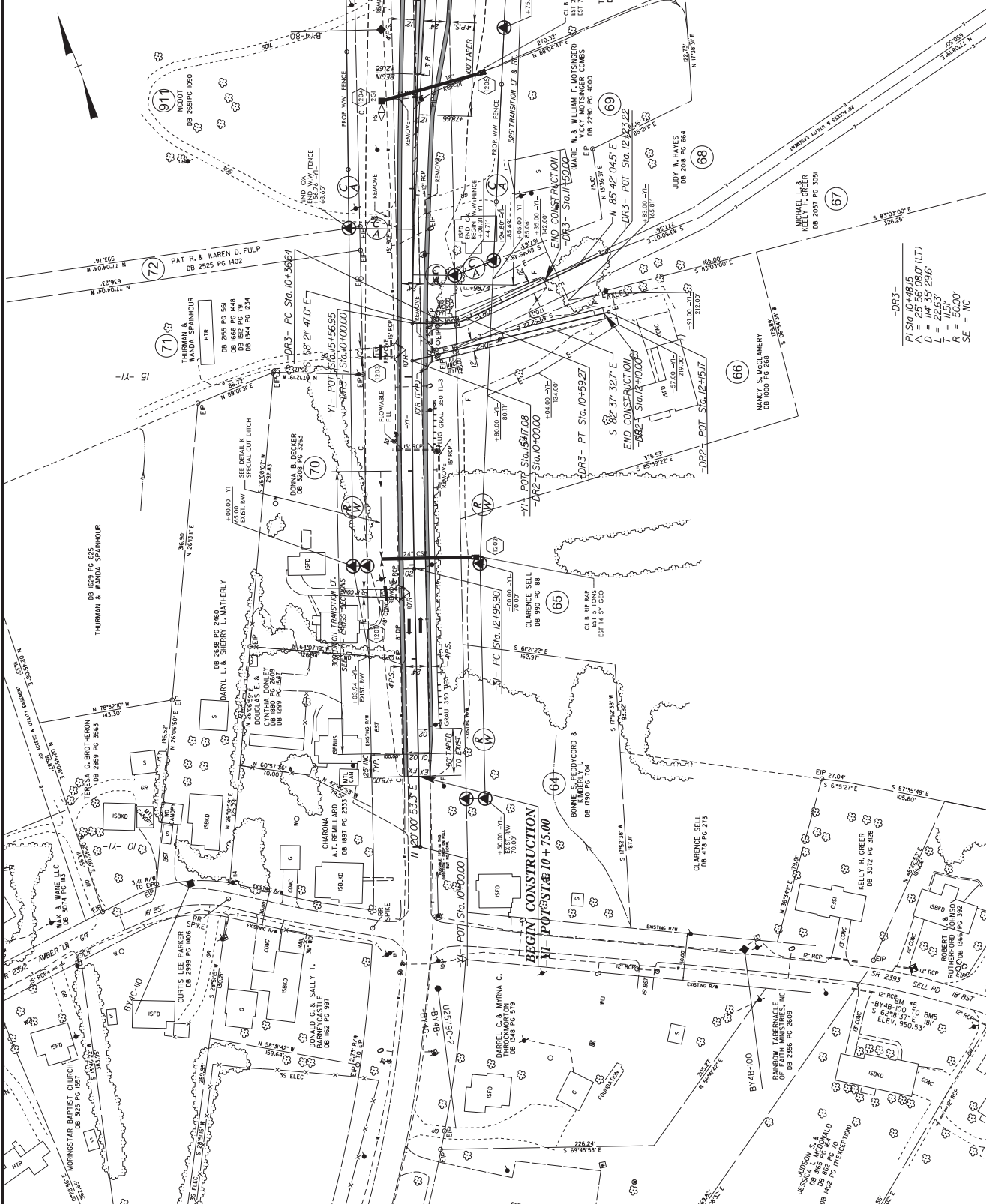

- PAVED SHOULDER
- PROP. CONCRETE 5'
- MONOLITHIC ISLAND

NOTE: -Y1- PROFILE SEE SHEET 22 FOR -DR2- PROFILE SEE SHEET 32 FOR -DR3- PROFILE SEE SHEET 33

-DR3-  
 $Pi$  Sta. 10+48.15  
 $\Delta$  = 42.56' (80.27' LT)  
 $L$  = 22.63'  
 $T$  = 41.51'  
 $R$  = 500.00'  
 $SE$  = NC

RIGHT OF WAY REVISION 5/3/17 - REVISED TCE ON PARCEL 67; ADD TCE ON PARCEL 88, JMB  
 REVISIONS  
 03-MAY-2017 10:44 01-2579C.psd.12.dgn  
 8/17/99

PROJECT REFERENCE NO.	U-2579C
SHEET NO.	13
BY	ROADWAY DESIGN ENGINEER
CHECKED BY	HYDRAULICS ENGINEER
DOCUMENT NOT CONSIDERED FINAL UNLESS ALL SIGNATURES COMPLETED	

# P-57



YIDET - PLS10 25497.68  
 $\Delta = 174.3$   
 $D = 229.280'$   
 $L = 168.77'$   
 $R = 2300.00'$   
 $SE = 02$   
 RO = SEE PLANS

YIDET - PLS10 3474.91  
 $\Delta = 11.06$   
 $D = 2.69$   
 $L = 229.280'$   
 $R = 2300.00'$   
 $SE = 02$   
 RO = SEE PLANS

- PAVED SHOULDER
- PROP. CONCRETE, 5'
- MONOLITHIC ISLAND

NOTE:  
 FOR -VI- PROFILE, SEE SHEET 23  
 FOR -YIDET- PROFILE, SEE SHEET 30  
 FOR -YIDET- PLAN, SEE SHEET 2B-5 & 2B-6



# P-58

PROJECT REFERENCE NO.	U-2579C	SHEET NO.	14
REVISED DESIGN ENGINEER		REGISTERED PROFESSIONAL ENGINEER	
<b>DOCUMENT NOT CONSIDERED FINAL UNLESS ALL SIGNATURES COMPLETED</b>			



-Y2DET -  
 PLSW 15.57778  
 $\Delta = 26.57' 47.47" (RT)$   
 $D = 10' 44.568"$   
 $L = 250.93'$   
 $R = 125.465'$   
 $SE = RC$

NOTE: -Y2- PROFILE SEE SHEET 28  
 FOR -Y2DET- PLAN, SEE SHEET 28-7  
 FOR -Y2DET- PROFILE, SEE SHEET 31

County : Forsyth

Line #	Item Number	Sec #	Description	Quantity	Unit Cost	Amount
<b>ROADWAY ITEMS</b>						
0001	0000100000-N	800	MOBILIZATION	Lump Sum	L.S.	
0002	0000400000-N	801	CONSTRUCTION SURVEYING	Lump Sum	L.S.	
0003	0001000000-E	200	CLEARING & GRUBBING .. ACRE(S)	Lump Sum	L.S.	
0004	0008000000-E	200	SUPPLEMENTARY CLEARING & GRUB- BING	4 ACR		
0005	0015000000-N	205	SEALING ABANDONED WELLS	8 EA		
0006	0022000000-E	225	UNCLASSIFIED EXCAVATION	1,350,000 CY		
0007	0029000000-N	SP	REINFORCED BRIDGE APPROACH FILL, STATION ***** (21+27.27 -Y2-)	Lump Sum	L.S.	
0008	0029000000-N	SP	REINFORCED BRIDGE APPROACH FILL, STATION ***** (29+24.97 -Y1-)	Lump Sum	L.S.	
0009	0029000000-N	SP	REINFORCED BRIDGE APPROACH FILL, STATION ***** (473+47.45 -L- LT)	Lump Sum	L.S.	
0010	0029000000-N	SP	REINFORCED BRIDGE APPROACH FILL, STATION ***** (473+47.45 -L- RT)	Lump Sum	L.S.	
0011	0036000000-E	225	UNDERCUT EXCAVATION	10,000 CY		
0012	0106000000-E	230	BORROW EXCAVATION	1,700,000 CY		
0013	0127000000-N	SP	EMBANKMENT SETTLEMENT GAUGES	2 EA		
0014	0134000000-E	240	DRAINAGE DITCH EXCAVATION	19,500 CY		
0015	0141000000-E	240	BERM DITCH CONSTRUCTION	1,060 LF		
0016	0156000000-E	250	REMOVAL OF EXISTING ASPHALT PAVEMENT	19,620 SY		
0017	0177000000-E	250	BREAKING OF EXISTING ASPHALT PAVEMENT	1,230 SY		
0018	0192000000-N	260	PROOF ROLLING	40 HR		

County : Forsyth

Line #	Item Number	Sec #	Description	Quantity	Unit Cost	Amount
0019	0195000000-E	265	SELECT GRANULAR MATERIAL	35,900		CY
0020	0196000000-E	270	GEOTEXTILE FOR SOIL STABILIZATION	48,600		SY
0021	0318000000-E	300	FOUNDATION CONDITIONING MATERIAL, MINOR STRUCTURES	2,029		TON
0022	0320000000-E	300	FOUNDATION CONDITIONING GEOTEXTILE	6,911		SY
0023	0342000000-E	310	*** SIDE DRAIN PIPE (36")	224		LF
0024	0343000000-E	310	15" SIDE DRAIN PIPE	1,412		LF
0025	0344000000-E	310	18" SIDE DRAIN PIPE	368		LF
0026	0345000000-E	310	24" SIDE DRAIN PIPE	300		LF
0027	0348000000-E	310	*** SIDE DRAIN PIPE ELBOWS (15")	14		EA
0028	0348000000-E	310	*** SIDE DRAIN PIPE ELBOWS (18")	6		EA
0029	0348000000-E	310	*** SIDE DRAIN PIPE ELBOWS (24")	2		EA
0030	0354000000-E	310	**** RC PIPE CULVERTS, CLASS ***** (24", V)	228		LF
0031	0366000000-E	310	15" RC PIPE CULVERTS, CLASS III	4,044		LF
0032	0372000000-E	310	18" RC PIPE CULVERTS, CLASS III	1,628		LF
0033	0378000000-E	310	24" RC PIPE CULVERTS, CLASS III	464		LF
0034	0384000000-E	310	30" RC PIPE CULVERTS, CLASS III	1,200		LF
0035	0390000000-E	310	36" RC PIPE CULVERTS, CLASS III	448		LF

County : Forsyth

Line #	Item Number	Sec #	Description	Quantity	Unit Cost	Amount
0036	0396000000-E	310	42" RC PIPE CULVERTS, CLASS III	220 LF		
0037	0448000000-E	310	***** RC PIPE CULVERTS, CLASS IV (60")	260 LF		
0038	0448000000-E	310	***** RC PIPE CULVERTS, CLASS IV (72")	244 LF		
0039	0448200000-E	310	15" RC PIPE CULVERTS, CLASS IV	2,988 LF		
0040	0448300000-E	310	18" RC PIPE CULVERTS, CLASS IV	512 LF		
0041	0448400000-E	310	24" RC PIPE CULVERTS, CLASS IV	800 LF		
0042	0448600000-E	310	36" RC PIPE CULVERTS, CLASS IV	84 LF		
0043	0448700000-E	310	42" RC PIPE CULVERTS, CLASS IV	288 LF		
0044	0576000000-E	310	*** CS PIPE CULVERTS, ***** THICK (60", 0.138")	1,144 LF		
0045	0576000000-E	310	*** CS PIPE CULVERTS, ***** THICK (78", 0.138")	252 LF		
0046	0594000000-E	310	24" CS PIPE CULVERTS, 0.064" THICK	380 LF		
0047	0654000000-E	310	*** X *** CS PIPE ARCH CULVERTS, ***** THICK (95" X 67", 0.109")	45 LF		
0048	0995000000-E	340	PIPE REMOVAL	1,940 LF		
0049	1000000000-E	462	6" SLOPE PROTECTION	500 SY		
0050	1011000000-N	500	FINE GRADING	Lump Sum	L.S.	
0051	1044000000-E	501	LIME TREATED SOIL (SLURRY METHOD)	64,560 SY		
0052	1066000000-E	501	LIME FOR LIME TREATED SOIL	650 TON		

County : Forsyth

Line #	Item Number	Sec #	Description	Quantity	Unit Cost	Amount
0053	1077000000-E	SP	#57 STONE	20 TON		
0054	1099500000-E	505	SHALLOW UNDERCUT	5,000 CY		
0055	1099700000-E	505	CLASS IV SUBGRADE STABILIZATION	9,500 TON		
0056	1110000000-E	510	STABILIZER AGGREGATE	500 TON		
0057	1115000000-E	SP	GEOTEXTILE FOR PAVEMENT STABILIZATION	84,754 SY		
0058	1176000000-E	542	SOIL CEMENT BASE	96,840 SY		
0059	1187000000-E	542	PORTLAND CEMENT FOR SOIL CEMENT BASE	2,670 TON		
0060	1209000000-E	543	ASPHALT CURING SEAL	24,210 GAL		
0061	1220000000-E	545	INCIDENTAL STONE BASE	1,000 TON		
0062	1489000000-E	610	ASPHALT CONC BASE COURSE, TYPE B25.0B	2,620 TON		
0063	1498000000-E	610	ASPHALT CONC INTERMEDIATE COURSE, TYPE I19.0B	1,230 TON		
0064	1503000000-E	610	ASPHALT CONC INTERMEDIATE COURSE, TYPE I19.0C	30,170 TON		
0065	1519000000-E	610	ASPHALT CONC SURFACE COURSE, TYPE S9.5B	1,970 TON		
0066	1523000000-E	610	ASPHALT CONC SURFACE COURSE, TYPE S9.5C	25,440 TON		
0067	1525000000-E	610	ASPHALT CONC SURFACE COURSE, TYPE SF9.5A	1,100 TON		
0068	1693000000-E	654	ASPHALT PLANT MIX, PAVEMENT REPAIR	90 TON		
0069	1840000000-E	665	MILLED RUMBLE STRIPS (ASPHALT CONCRETE)	36,200 LF		
0070	2000000000-N	806	RIGHT OF WAY MARKERS	114 EA		

County : Forsyth

Line #	Item Number	Sec #	Description	Quantity	Unit Cost	Amount
0071	2022000000-E	815	SUBDRAIN EXCAVATION	5,024 CY		
0072	2033000000-E	815	SUBDRAIN FINE AGGREGATE	2,512 CY		
0073	2044000000-E	815	6" PERFORATED SUBDRAIN PIPE	14,950 LF		
0074	2070000000-N	815	SUBDRAIN PIPE OUTLET	30 EA		
0075	2077000000-E	815	6" OUTLET PIPE	180 LF		
0076	2099000000-E	816	SHOULDER DRAIN	7,360 LF		
0077	2110000000-E	816	4" SHOULDER DRAIN PIPE	7,360 LF		
0078	2121000000-E	816	4" OUTLET PIPE FOR SHOULDER DRAINS	270 LF		
0079	2132000000-N	816	CONCRETE PAD FOR SHOULDER DRAIN PIPE OUTLET	9 EA		
0080	2143000000-E	818	BLOTTING SAND	15 TON		
0081	2209000000-E	838	ENDWALLS	9 CY		
0082	2220000000-E	838	REINFORCED ENDWALLS	53 CY		
0083	2253000000-E	840	PIPE COLLARS	1 CY		
0084	2275000000-E	SP	FLOWABLE FILL	4 CY		
0085	2286000000-N	840	MASONRY DRAINAGE STRUCTURES	92 EA		
0086	2297000000-E	840	MASONRY DRAINAGE STRUCTURES	32 CY		
0087	2308000000-E	840	MASONRY DRAINAGE STRUCTURES	53.2 LF		
0088	2354000000-N	840	FRAME WITH GRATE, STD 840.22	1 EA		
0089	2364000000-N	840	FRAME WITH TWO GRATES, STD 840.16	3 EA		
0090	2364200000-N	840	FRAME WITH TWO GRATES, STD 840.20	31 EA		

County : Forsyth

Line #	Item Number	Sec #	Description	Quantity	Unit Cost	Amount
0091	2365000000-N	840	FRAME WITH TWO GRATES, STD 840.22	50 EA		
0092	2367000000-N	840	FRAME WITH TWO GRATES, STD 840.29	2 EA		
0093	2374000000-N	840	FRAME WITH GRATE & HOOD, STD 840.03, TYPE ** (G)	2 EA		
0094	2396000000-N	840	FRAME WITH COVER, STD 840.54	4 EA		
0095	2451000000-N	852	CONCRETE TRANSITIONAL SECTION FOR DROP INLET	3 EA		
0096	2462000000-E	SP	*** SLUICE GATE (8")	2 EA		
0097	2549000000-E	846	2'-6" CONCRETE CURB & GUTTER	1,110 LF		
0098	2556000000-E	846	SHOULDER BERM GUTTER	4,290 LF		
0099	2577000000-E	846	CONCRETE EXPRESSWAY GUTTER	640 LF		
0100	2612000000-E	848	6" CONCRETE DRIVEWAY	1,250 SY		
0101	2619000000-E	850	4" CONCRETE PAVED DITCH	42 SY		
0102	2655000000-E	852	5" MONOLITHIC CONCRETE ISLANDS (KEYED IN)	2,180 SY		
0103	2830000000-N	858	ADJUSTMENT OF MANHOLES	1 EA		
0104	2845000000-N	858	ADJUSTMENT OF METER BOXES OR VALVE BOXES	6 EA		
0105	3030000000-E	862	STEEL BM GUARDRAIL	28,000 LF		
0106	3105000000-N	862	STEEL BM GUARDRAIL TERMINAL SECTIONS	2 EA		
0107	3150000000-N	862	ADDITIONAL GUARDRAIL POSTS	10 EA		
0108	3210000000-N	862	GUARDRAIL ANCHOR UNITS, TYPE CAT-1	17 EA		

County : Forsyth

Line #	Item Number	Sec #	Description	Quantity	Unit Cost	Amount
0109	3215000000-N	862	GUARDRAIL ANCHOR UNITS, TYPE III	5 EA		
0110	3287000000-N	SP	GUARDRAIL END UNITS, TYPE TL-3	23 EA		
0111	3288000000-N	SP	GUARDRAIL END UNITS, TYPE TL-2	4 EA		
0112	3317000000-N	862	GUARDRAIL ANCHOR UNITS, TYPE B-77	12 EA		
0113	3380000000-E	862	TEMPORARY STEEL BM GUARDRAIL	1,200 LF		
0114	3389150000-N	SP	TEMPORARY GUARDRAIL END UNITS, TYPE ***** (TL-3)	6 EA		
0115	3503000000-E	866	WOVEN WIRE FENCE, 47" FABRIC	24,560 LF		
0116	3509000000-E	866	4" TIMBER FENCE POSTS, 7'-6" LONG	1,520 EA		
0117	3515000000-E	866	5" TIMBER FENCE POSTS, 8'-0" LONG	440 EA		
0118	3628000000-E	876	RIP RAP, CLASS I	3,500 TON		
0119	3635000000-E	876	RIP RAP, CLASS II	800 TON		
0120	3642000000-E	876	RIP RAP, CLASS A	20 TON		
0121	3649000000-E	876	RIP RAP, CLASS B	5,400 TON		
0122	3651000000-E	SP	BOULDERS	15 TON		
0123	3656000000-E	876	GEOTEXTILE FOR DRAINAGE	25,050 SY		
0124	4054000000-E	902	PLAIN CONCRETE SIGN FOUNDATIONS	1 CY		
0125	4057000000-E	SP	OVERHEAD FOOTING	51 CY		
0126	4060000000-E	903	SUPPORTS, BREAKAWAY STEEL BEAM	472 LB		
0127	4072000000-E	903	SUPPORTS, 3-LB STEEL U-CHANNEL	2,701 LF		



County : Forsyth

Line #	Item Number	Sec #	Description	Quantity	Unit Cost	Amount
0128	4082100000-N	SP	SUPPORTS, OVERHEAD SIGN STRUCTURE AT STA ***** (410+00 -L-)	Lump Sum	L.S.	
0129	4082100000-N	SP	SUPPORTS, OVERHEAD SIGN STRUCTURE AT STA ***** (458+00 -L-)	Lump Sum	L.S.	
0130	4082100000-N	SP	SUPPORTS, OVERHEAD SIGN STRUCTURE AT STA ***** (459+00 -L-)	Lump Sum	L.S.	
0131	4082100000-N	SP	SUPPORTS, OVERHEAD SIGN STRUCTURE AT STA ***** (481+00 -L-)	Lump Sum	L.S.	
0132	4096000000-N	904	SIGN ERECTION, TYPE D	7 EA		
0133	4102000000-N	904	SIGN ERECTION, TYPE E	83 EA		
0134	4108000000-N	904	SIGN ERECTION, TYPE F	15 EA		
0135	4109000000-N	904	SIGN ERECTION, TYPE *** (OVERHEAD) (A)	6 EA		
0136	4109000000-N	904	SIGN ERECTION, TYPE *** (OVERHEAD) (B)	1 EA		
0137	4110000000-N	904	SIGN ERECTION, TYPE *** (GROUND MOUNTED) (A)	2 EA		
0138	4110000000-N	904	SIGN ERECTION, TYPE *** (GROUND MOUNTED) (B)	2 EA		
0139	4114000000-N	904	SIGN ERECTION, MILEMARKERS	6 EA		
0140	4115000000-N	904	SIGN ERECTION, OVERLAY (OVERHEAD)	16 EA		
0141	4116100000-N	904	SIGN ERECTION, RELOCATE, TYPE **** (GROUND MOUNTED) (D)	1 EA		
0142	4116100000-N	904	SIGN ERECTION, RELOCATE, TYPE **** (GROUND MOUNTED) (F)	3 EA		

County : Forsyth

Line #	Item Number	Sec #	Description	Quantity	Unit Cost	Amount
0143	4116200000-N	904	SIGN ERECTION, REPOSITION OVERHEAD	4 EA		
0144	4155000000-N	907	DISPOSAL OF SIGN SYSTEM, U-CHANNEL	22 EA		
0145	4192000000-N	907	DISPOSAL OF SUPPORT, U-CHANNEL	2 EA		
0146	4234000000-N	907	DISPOSAL OF SIGN, A OR B (OVERHEAD)	4 EA		
0147	4400000000-E	1110	WORK ZONE SIGNS (STATIONARY)	833 SF		
0148	4405000000-E	1110	WORK ZONE SIGNS (PORTABLE)	192 SF		
0149	4410000000-E	1110	WORK ZONE SIGNS (BARRICADE MOUNTED)	342 SF		
0150	4422000000-N	1120	PORTABLE CHANGEABLE MESSAGE SIGN (SHORT TERM)	21 DAY		
0151	4430000000-N	1130	DRUMS	200 EA		
0152	4435000000-N	1135	CONES	50 EA		
0153	4445000000-E	1145	BARRICADES (TYPE III)	384 LF		
0154	4455000000-N	1150	FLAGGER	140 DAY		
0155	4516000000-N	1180	SKINNY DRUM	50 EA		
0156	4520000000-N	1266	TUBULAR MARKERS (FIXED)	18 EA		
0157	4650000000-N	1251	TEMPORARY RAISED PAVEMENT MARKERS	193 EA		
0158	4700000000-E	1205	THERMOPLASTIC PAVEMENT MARKING LINES (12", 90 MILS)	310 LF		
0159	4705000000-E	1205	THERMOPLASTIC PAVEMENT MARKING LINES (16", 120 MILS)	46 LF		
0160	4710000000-E	1205	THERMOPLASTIC PAVEMENT MARKING LINES (24", 120 MILS)	256 LF		

County : Forsyth

Line #	Item Number	Sec #	Description	Quantity	Unit Cost	Amount
0161	4721000000-E	1205	THERMOPLASTIC PAVEMENT MARKING CHARACTER (120 MILS)	2 EA		
0162	4725000000-E	1205	THERMOPLASTIC PAVEMENT MARKING SYMBOL (90 MILS)	57 EA		
0163	4810000000-E	1205	PAINT PAVEMENT MARKING LINES (4")	67,704 LF		
0164	4815000000-E	1205	PAINT PAVEMENT MARKING LINES (6")	14,090 LF		
0165	4825000000-E	1205	PAINT PAVEMENT MARKING LINES (12")	3,830 LF		
0166	4835000000-E	1205	PAINT PAVEMENT MARKING LINES (24")	10 LF		
0167	4845000000-N	1205	PAINT PAVEMENT MARKING SYMBOL	32 EA		
0168	4847000000-E	1205	POLYUREA PAVEMENT MARKING LINES (4", *****) (HIGHLY REFLECTIVE ELEMENTS)	31,888 LF		
0169	4847100000-E	1205	POLYUREA PAVEMENT MARKING LINES (6", *****) (HIGHLY REFLECTIVE ELEMENTS)	75,872 LF		
0170	4847120000-E	1205	POLYUREA PAVEMENT MARKING LINES (12", *****) (HIGHLY REFLECTIVE ELEMENTS)	4,324 LF		
0171	4850000000-E	1205	REMOVAL OF PAVEMENT MARKING LINES (4")	4,432 LF		
0172	4855000000-E	1205	REMOVAL OF PAVEMENT MARKING LINES (6")	23,230 LF		
0173	4860000000-E	1205	REMOVAL OF PAVEMENT MARKING LINES (8")	385 LF		
0174	4865000000-E	1205	REMOVAL OF PAVEMENT MARKING LINES (12")	3,150 LF		
0175	4870000000-E	1205	REMOVAL OF PAVEMENT MARKING LINES (24")	10 LF		
0176	4875000000-N	1205	REMOVAL OF PAVEMENT MARKING SYMBOLS & CHARACTERS	5 EA		

County : Forsyth

Line #	Item Number	Sec #	Description	Quantity	Unit Cost	Amount
0177	4900000000-N	1251	PERMANENT RAISED PAVEMENT MARKERS	257 EA		
0178	4905000000-N	1253	SNOWPLOWABLE PAVEMENT MARKERS	1,247 EA		
0179	4915000000-E	1264	7' U-CHANNEL POSTS	3 EA		
0180	4935000000-N	1267	FLEXIBLE DELINEATORS (CRYSTAL)	65 EA		
0181	4940000000-N	1267	FLEXIBLE DELINEATORS (YELLOW)	62 EA		
0182	4945000000-N	1267	FLEXIBLE DELINEATORS (CRYSTAL & RED)	10 EA		
0183	4950000000-N	1267	FLEXIBLE DELINEATORS (YELLOW & RED)	55 EA		
0184	4955000000-N	1264	OBJECT MARKERS (END OF ROAD)	3 EA		
0185	5326200000-E	1510	12" WATER LINE	1,452 LF		
0186	5326600000-E	1510	16" WATER LINE	2,245 LF		
0187	5329000000-E	SP	DUCTILE IRON WATER PIPE FITTINGS	8,030 LB		
0188	5572200000-E	1515	12" TAPPING VALVE	2 EA		
0189	5572600000-E	1515	16" TAPPING VALVE	2 EA		
0190	5589100000-E	1515	1" AIR RELEASE VALVE	2 EA		
0191	5606600000-E	1515	6" BLOW OFF	1 EA		
0192	5648000000-N	1515	RELOCATE WATER METER	8 EA		
0193	5672000000-N	1515	RELOCATE FIRE HYDRANT	5 EA		
0194	5801000000-E	1530	ABANDON 8" UTILITY PIPE	222 LF		
0195	5804000000-E	1530	ABANDON 12" UTILITY PIPE	440 LF		
0196	5810000000-E	1530	ABANDON 16" UTILITY PIPE	355 LF		

County : Forsyth

Line #	Item Number	Sec #	Description	Quantity	Unit Cost	Amount
0197	5815000000-N	1530	REMOVE WATER METER	4 EA		
0198	5815500000-N	1530	REMOVE FIRE HYDRANT	2 EA		
0199	5816000000-N	1530	ABANDON UTILITY MANHOLE	2 EA		
0200	5828000000-N	1530	REMOVE UTILITY MANHOLE	1 EA		
0201	5836000000-E	1540	24" ENCASEMENT PIPE	210 LF		
0202	5836200000-E	1540	30" ENCASEMENT PIPE	305 LF		
0203	5882000000-N	SP	GENERIC UTILITY ITEM ABANDON SEWER CONNECTION	2 EA		
0204	6000000000-E	1605	TEMPORARY SILT FENCE	92,500 LF		
0205	6006000000-E	1610	STONE FOR EROSION CONTROL, CLASS A	2,250 TON		
0206	6009000000-E	1610	STONE FOR EROSION CONTROL, CLASS B	41,000 TON		
0207	6012000000-E	1610	SEDIMENT CONTROL STONE	34,885 TON		
0208	6015000000-E	1615	TEMPORARY MULCHING	302.5 ACR		
0209	6018000000-E	1620	SEED FOR TEMPORARY SEEDING	12,800 LB		
0210	6021000000-E	1620	FERTILIZER FOR TEMPORARY SEED- ING	65.5 TON		
0211	6024000000-E	1622	TEMPORARY SLOPE DRAINS	32,500 LF		
0212	6029000000-E	SP	SAFETY FENCE	14,000 LF		
0213	6030000000-E	1630	SILT EXCAVATION	385,600 CY		
0214	6036000000-E	1631	MATTING FOR EROSION CONTROL	420,500 SY		
0215	6037000000-E	SP	COIR FIBER MAT	750 SY		
0216	6038000000-E	SP	PERMANENT SOIL REINFORCEMENT MAT	2,500 SY		

County : Forsyth

Line #	Item Number	Sec #	Description	Quantity	Unit Cost	Amount
0217	6042000000-E	1632	1/4" HARDWARE CLOTH	7,500	LF	
0218	6045000000-E	SP	*** TEMPORARY PIPE (18")	230	LF	
0219	6046000000-E	1636	TEMPORARY PIPE FOR STREAM CROSSING	200	LF	
0220	6070000000-N	1639	SPECIAL STILLING BASINS	24	EA	
0221	6071012000-E	SP	COIR FIBER WATTLE	9,500	LF	
0222	6071020000-E	SP	POLYACRYLAMIDE (PAM)	8,550	LB	
0223	6071030000-E	1640	COIR FIBER BAFFLE	33,500	LF	
0224	6071050000-E	SP	*** SKIMMER (1-1/2")	28	EA	
0225	6071050000-E	SP	*** SKIMMER (2")	14	EA	
0226	6071050000-E	SP	*** SKIMMER (2-1/2")	10	EA	
0227	6071050000-E	SP	*** SKIMMER (3")	2	EA	
0228	6071050000-E	SP	*** SKIMMER (4")	1	EA	
0229	6084000000-E	1660	SEEDING & MULCHING	250	ACR	
0230	6087000000-E	1660	MOWING	250	ACR	
0231	6090000000-E	1661	SEED FOR REPAIR SEEDING	3,000	LB	
0232	6093000000-E	1661	FERTILIZER FOR REPAIR SEEDING	12.75	TON	
0233	6096000000-E	1662	SEED FOR SUPPLEMENTAL SEEDING	7,075	LB	
0234	6108000000-E	1665	FERTILIZER TOPDRESSING	211.75	TON	
0235	6111000000-E	SP	IMPERVIOUS DIKE	547	LF	

County : Forsyth

Line #	Item Number	Sec #	Description	Quantity	Unit Cost	Amount
0236	6114500000-N	1667	SPECIALIZED HAND MOWING	130	MHR	
0237	6117000000-N	SP	RESPONSE FOR EROSION CONTROL	125	EA	
0238	6120000000-E	SP	CULVERT DIVERSION CHANNEL	1,244	CY	
0239	6123000000-E	1670	REFORESTATION	10	ACR	
0240	6132000000-N	SP	GENERIC EROSION CONTROL ITEM CONCRETE WASHOUT STRUCTURE	10	EA	
0241	7060000000-E	1705	SIGNAL CABLE	1,700	LF	
0242	7120000000-E	1705	VEHICLE SIGNAL HEAD (12", 3 SECTION)	12	EA	
0243	7132000000-E	1705	VEHICLE SIGNAL HEAD (12", 4 SECTION)	1	EA	
0244	7252000000-E	1710	MESSENGER CABLE (1/4")	300	LF	
0245	7264000000-E	1710	MESSENGER CABLE (3/8")	1,025	LF	
0246	7279000000-E	1715	TRACER WIRE	9,500	LF	
0247	7300000000-E	1715	UNPAVED TRENCHING (***** (1,2")	1,700	LF	
0248	7300000000-E	1715	UNPAVED TRENCHING (***** (2,2")	9,100	LF	
0249	7300000000-E	1715	UNPAVED TRENCHING (***** (3,2")	100	LF	
0250	7301000000-E	1715	DIRECTIONAL DRILL (***** (2,2")	300	LF	
0251	7301000000-E	1715	DIRECTIONAL DRILL (***** (4,2")	400	LF	
0252	7312000000-N	1716	JUNCTION BOX (***** (SPECIAL OVER-SIZED HEAVY DUTY)	2	EA	
0253	7324000000-N	1716	JUNCTION BOX (STANDARD SIZE)	25	EA	

County : Forsyth

Line #	Item Number	Sec #	Description	Quantity	Unit Cost	Amount
0254	7348000000-N	1716	JUNCTION BOX (OVER-SIZED, HEAVY DUTY)	22 EA		
0255	7360000000-N	1720	WOOD POLE	2 EA		
0256	7372000000-N	1721	GUY ASSEMBLY	2 EA		
0257	7432000000-E	1722	2" RISER WITH HEAT SHRINK TUBING	2 EA		
0258	7444000000-E	1725	INDUCTIVE LOOP SAWCUT	860 LF		
0259	7456000000-E	1726	LEAD-IN CABLE (*****)(14-2)	3,350 LF		
0260	7516000000-E	1730	COMMUNICATIONS CABLE (**FIBER)(72)	9,900 LF		
0261	7528000000-E	1730	DROP CABLE	700 LF		
0262	7540000000-N	1731	SPLICE ENCLOSURE	3 EA		
0263	7541000000-N	1731	MODIFY SPLICE ENCLOSURE	1 EA		
0264	7552000000-N	1731	INTERCONNECT CENTER	5 EA		
0265	7566000000-N	1733	DELINEATOR MARKER	24 EA		
0266	7575142000-N	1736	900MHZ RADIO	2 EA		
0267	7576000000-N	SP	METAL STRAIN SIGNAL POLE	8 EA		
0268	7613000000-N	SP	SOIL TEST	10 EA		
0269	7614100000-E	SP	DRILLED PIER FOUNDATION	58 CY		
0270	7636000000-N	1745	SIGN FOR SIGNALS	8 EA		
0271	7684000000-N	1750	SIGNAL CABINET FOUNDATION	2 EA		
0272	7756000000-N	1751	CONTROLLER WITH CABINET (TYPE 2070L, BASE MOUNTED)	2 EA		
0273	7780000000-N	1751	DETECTOR CARD (TYPE 2070L)	9 EA		



County : Forsyth

Line #	Item Number	Sec #	Description	Quantity	Unit Cost	Amount
0274	7901000000-N	1753	CABINET BASE EXTENDER	2		EA
0275	7980000000-N	SP	GENERIC SIGNAL ITEM 5/8" X 10' GROUNDING ELECTRODE	16		EA
0276	7980000000-N	SP	GENERIC SIGNAL ITEM CCTV CAMERA ASSEMBLY	2		EA
0277	7980000000-N	SP	GENERIC SIGNAL ITEM CCTV METAL POLE	2		EA
0278	7980000000-N	SP	GENERIC SIGNAL ITEM CENTRAL MEDIA CONVERTER	2		EA
0279	7980000000-N	SP	GENERIC SIGNAL ITEM DIGITAL HARDWARE VIDEO DECODER	2		EA
0280	7980000000-N	SP	GENERIC SIGNAL ITEM DMS	2		EA
0281	7980000000-N	SP	GENERIC SIGNAL ITEM DMS ACCESS LADDER	2		EA
0282	7980000000-N	SP	GENERIC SIGNAL ITEM DMS PEDESTAL STRUCTURE	2		EA
0283	7980000000-N	SP	GENERIC SIGNAL ITEM EQUIPMENT CABINET FOUNDATION	1		EA
0284	7980000000-N	SP	GENERIC SIGNAL ITEM EQUIPMENT CABINET DISCONNECT	4		EA
0285	7980000000-N	SP	GENERIC SIGNAL ITEM ETHERNET EDGE SWITCH	4		EA
0286	7980000000-N	SP	GENERIC SIGNAL ITEM FIBER-OPTIC SPLICE CABINET	1		EA
0287	7980000000-N	SP	GENERIC SIGNAL ITEM FIELD EQUIPMENT CABINET	2		EA
0288	7980000000-N	SP	GENERIC SIGNAL ITEM METER BASE/DISCONNECT COMBINA- TION PANEL	2		EA
0289	7980000000-N	SP	GENERIC SIGNAL ITEM WOOD PEDESTAL	2		EA

County : Forsyth

Line #	Item Number	Sec #	Description	Quantity	Unit Cost	Amount
0290	7985000000-N	SP	GENERIC SIGNAL ITEM INTEGRATION AND CONFIGURATION	Lump Sum	L.S.	
0291	7990000000-E	SP	GENERIC SIGNAL ITEM #4 SOLID BARE GROUNDING CON- DUCTOR	60 LF		
0292	7990000000-E	SP	GENERIC SIGNAL ITEM 3-WIRE COPPER FEEDER COND- UCTORS	300 LF		
0293	7990000000-E	SP	GENERIC SIGNAL ITEM 4-WIRE COPPER FEEDER COND- UCTORS	600 LF		
0294	7992000000-E	SP	GENERIC SIGNAL ITEM OVERHEAD DMS STRUCTURE FOOT- INGS	16 CY		

\*\*\*\*\* BEGIN SCHEDULE AA \*\*\*\*\*  
\*\*\*\*\* ( 2 ALTERNATES ) \*\*\*\*\*

0295	1121000000-E	520	AGGREGATE BASE COURSE	80,300 TON		
<b>AA1</b>						
0296	1491000000-E	610	ASPHALT CONC BASE COURSE, TYPE B25.0C	33,300 TON		
<b>AA1</b>						
0297	1575000000-E	620	ASPHALT BINDER FOR PLANT MIX	4,785 TON		
<b>AA1</b>						

\*\*\* OR \*\*\*

0298	1121000000-E	520	AGGREGATE BASE COURSE	4,020 TON		
<b>AA2</b>						
0299	1491000000-E	610	ASPHALT CONC BASE COURSE, TYPE B25.0C	78,860 TON		
<b>AA2</b>						
0300	1575000000-E	620	ASPHALT BINDER FOR PLANT MIX	6,790 TON		
<b>AA2</b>						

\*\*\*\*\* END SCHEDULE AA \*\*\*\*\*

**CULVERT ITEMS**

0301	8126000000-N	414	CULVERT EXCAVATION, STA ***** (397+73.00 -L-)	Lump Sum	L.S.	
0302	8126000000-N	414	CULVERT EXCAVATION, STA ***** (437+96.50 -L-)	Lump Sum	L.S.	

County : Forsyth

Line #	Item Number	Sec #	Description	Quantity	Unit Cost	Amount
0303	8133000000-E	414	FOUNDATION CONDITIONING MATERIAL, BOX CULVERT	974 TON		
0304	8196000000-E	420	CLASS A CONCRETE (CULVERT)	1,609.4 CY		
0305	8245000000-E	425	REINFORCING STEEL (CULVERT)	130,376 LB		

**STRUCTURE ITEMS**

0306	8091000000-N	410	FOUNDATION EXCAVATION FOR BENT ** AT STATION ***** (1, 21+27.27 -Y2-)	Lump Sum	L.S.	
0307	8091000000-N	410	FOUNDATION EXCAVATION FOR BENT ** AT STATION ***** (1, 29+24.97 -Y1-)	Lump Sum	L.S.	
0308	8105540000-E	411	3'-6" DIA DRILLED PIERS IN SOIL	564 LF		
0309	8105640000-E	411	3'-6" DIA DRILLED PIERS NOT IN SOIL	270 LF		
0310	8111400000-E	411	PERMANENT STEEL CASING FOR 3'-6" DIA DRILLED PIER	128 LF		
0311	8112730000-N	450	PDA TESTING	4 EA		
0312	8113000000-N	411	SID INSPECTIONS	2 EA		
0313	8114000000-N	411	SPT TESTING	16 EA		
0314	8115000000-N	411	CSL TESTING	2 EA		
0315	8147000000-E	420	REINFORCED CONCRETE DECK SLAB	59,989 SF		
0316	8161000000-E	420	GROOVING BRIDGE FLOORS	58,288 SF		
0317	8182000000-E	420	CLASS A CONCRETE (BRIDGE)	807.3 CY		
0318	8210000000-N	422	BRIDGE APPROACH SLABS, STATION ***** (21+27.27 -Y2-)	Lump Sum	L.S.	

County : Forsyth

Line #	Item Number	Sec #	Description	Quantity	Unit Cost	Amount
0319	8210000000-N	422	BRIDGE APPROACH SLABS, STATION ***** (29+24.97 -Y1-)	Lump Sum	L.S.	
0320	8210000000-N	422	BRIDGE APPROACH SLABS, STATION ***** (473+70.00 -L- LT)	Lump Sum	L.S.	
0321	8210000000-N	422	BRIDGE APPROACH SLABS, STATION ***** (473+70.00 -L- RT)	Lump Sum	L.S.	
0322	8217000000-E	425	REINFORCING STEEL (BRIDGE)	192,761 LB		
0323	8238000000-E	425	SPIRAL COLUMN REINFORCING STEEL (BRIDGE)	25,224 LB		
0324	8265000000-E	430	54" PRESTRESSED CONCRETE GIR- DERS	4,517.26 LF		
0325	8277000000-E	430	MODIFIED 72" PRESTRESSED CONC GIRDERS	2,180.17 LF		
0326	8328200000-E	SP	PILE DRIVING EQUIPMENT SETUP FOR *** STEEL PILES (12 X 53)	84 EA		
0327	8328200000-E	SP	PILE DRIVING EQUIPMENT SETUP FOR *** STEEL PILES (14 X 73)	38 EA		
0328	8364000000-E	450	HP12X53 STEEL PILES	4,465 LF		
0329	8384000000-E	450	HP14X73 STEEL PILES	830 LF		
0330	8391000000-N	450	STEEL PILE POINTS	38 EA		
0331	8475000000-E	460	TWO BAR METAL RAIL	423.76 LF		
0332	8503000000-E	460	CONCRETE BARRIER RAIL	1,451.1 LF		
0333	8517000000-E	460	1'-***X ***** CONCRETE PARA- PET (1'-2" X 3'-2 3/4")	439.13 LF		
0334	8531000000-E	462	4" SLOPE PROTECTION	1,489 SY		
0335	8608000000-E	876	RIP RAP CLASS II (2'-0" THICK)	2,000 TON		

County : Forsyth

---

Line #	Item Number	Sec #	Description	Quantity	Unit Cost	Amount
0336	8622000000-E	876	GEOTEXTILE FOR DRAINAGE	2,220 SY		
0337	8657000000-N	430	ELASTOMERIC BEARINGS	Lump Sum	L.S.	

---

---

1632/Aug08/Q5843703.82/D1520553034000/E337

Total Amount Of Bid For Entire Project :

---