

Polypropylene Manhole Step

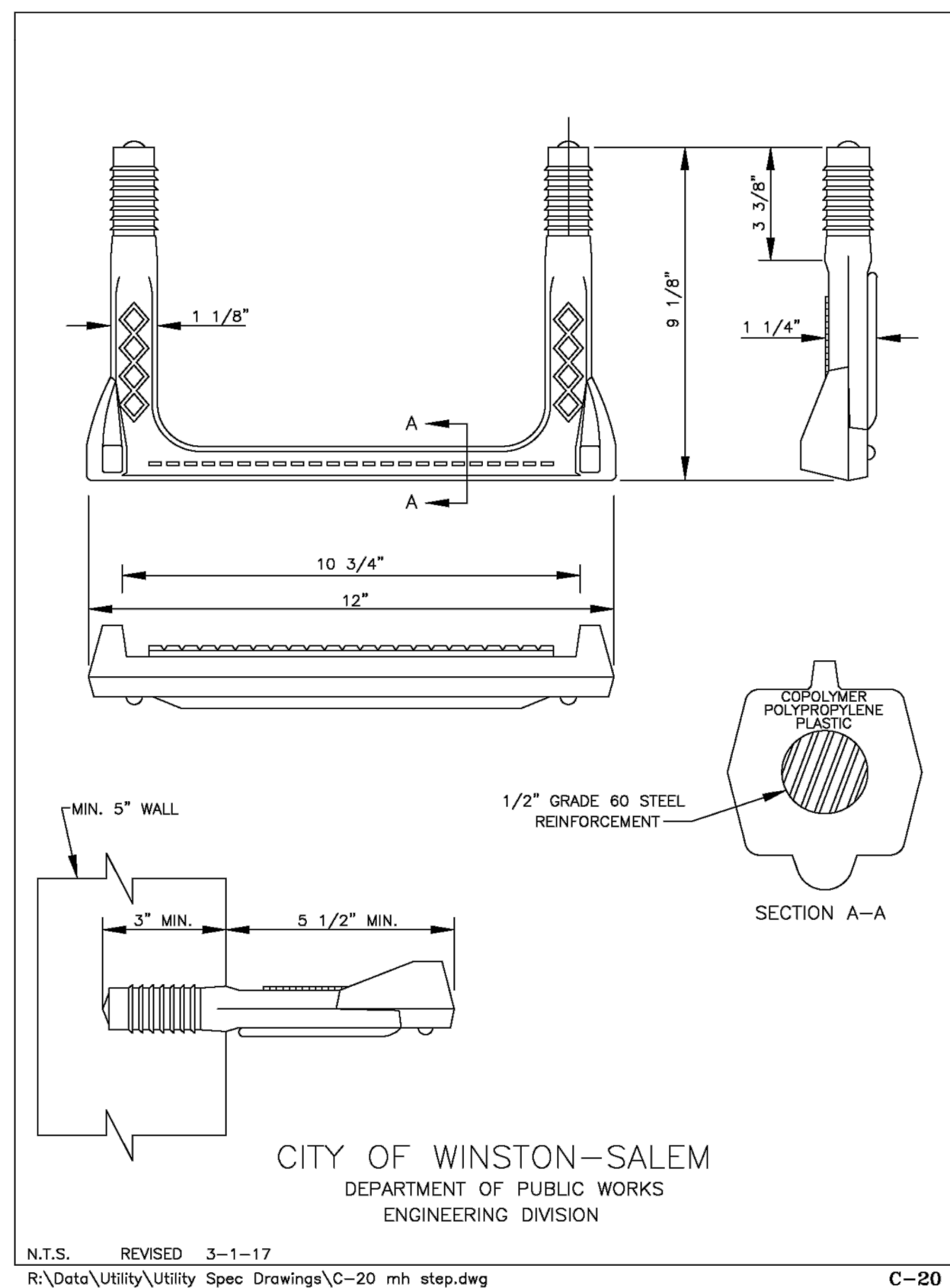

Cast Iron Valve Box

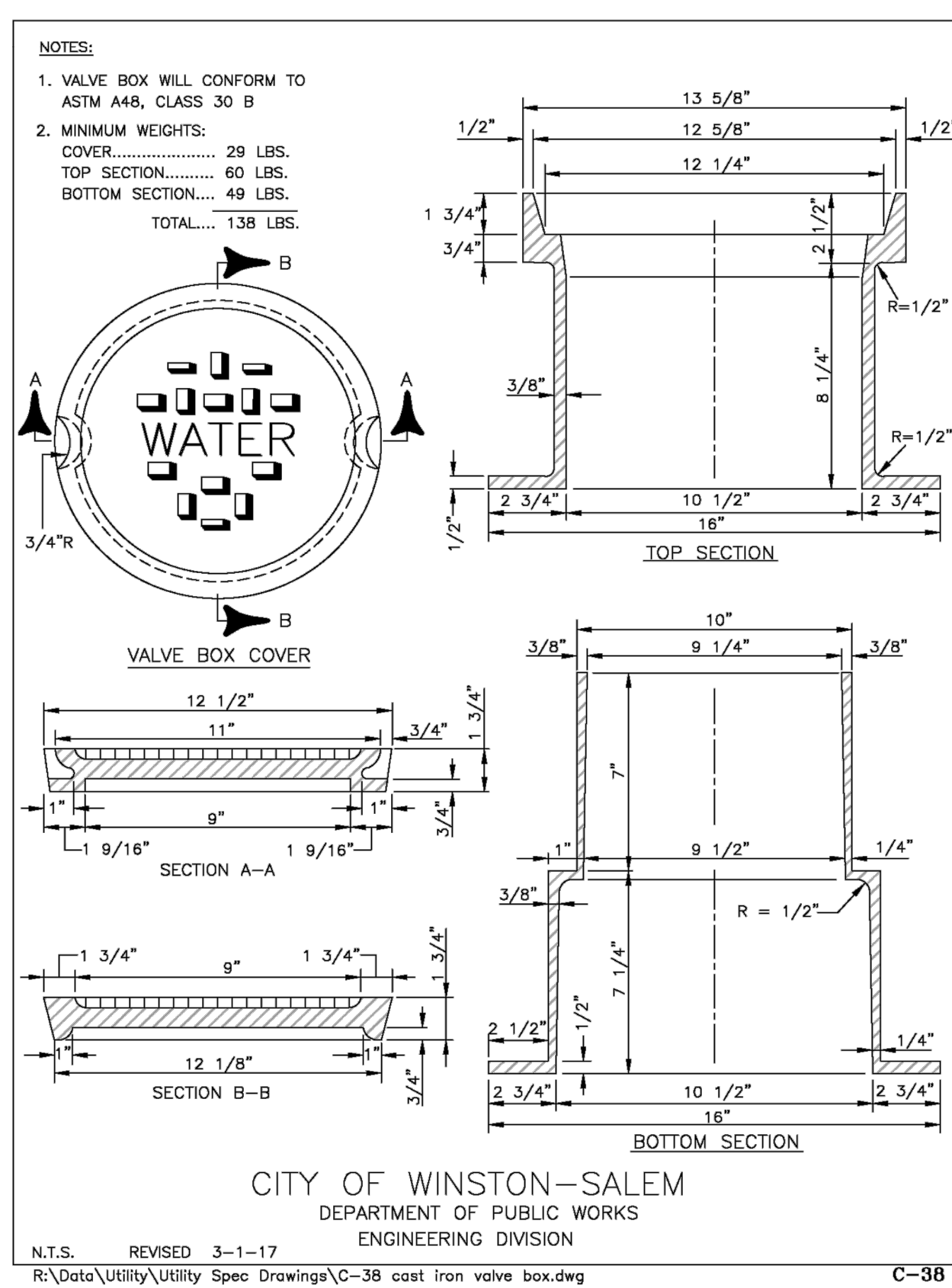

Valve Box Installation

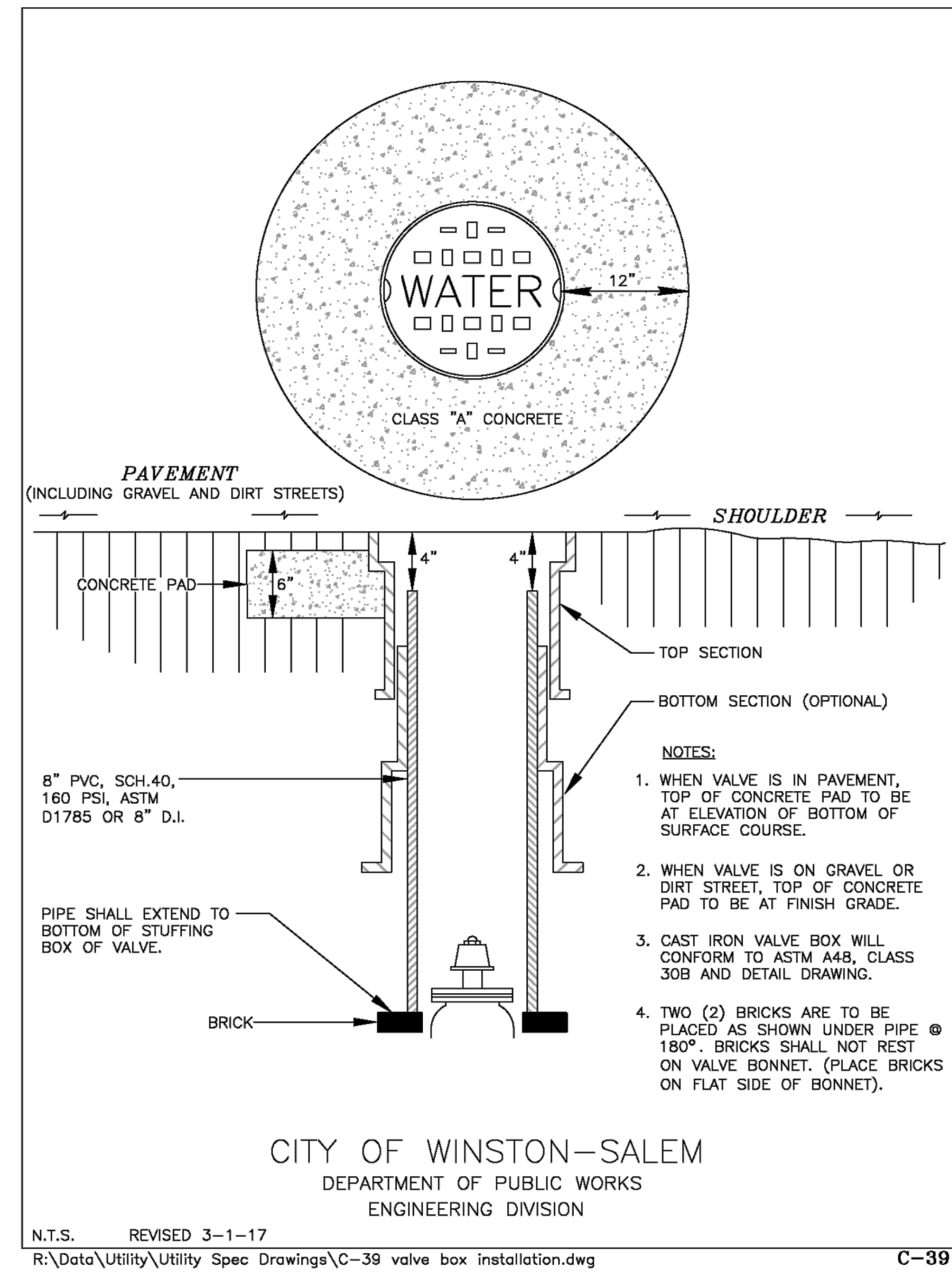

Hydrant and Valve Installation

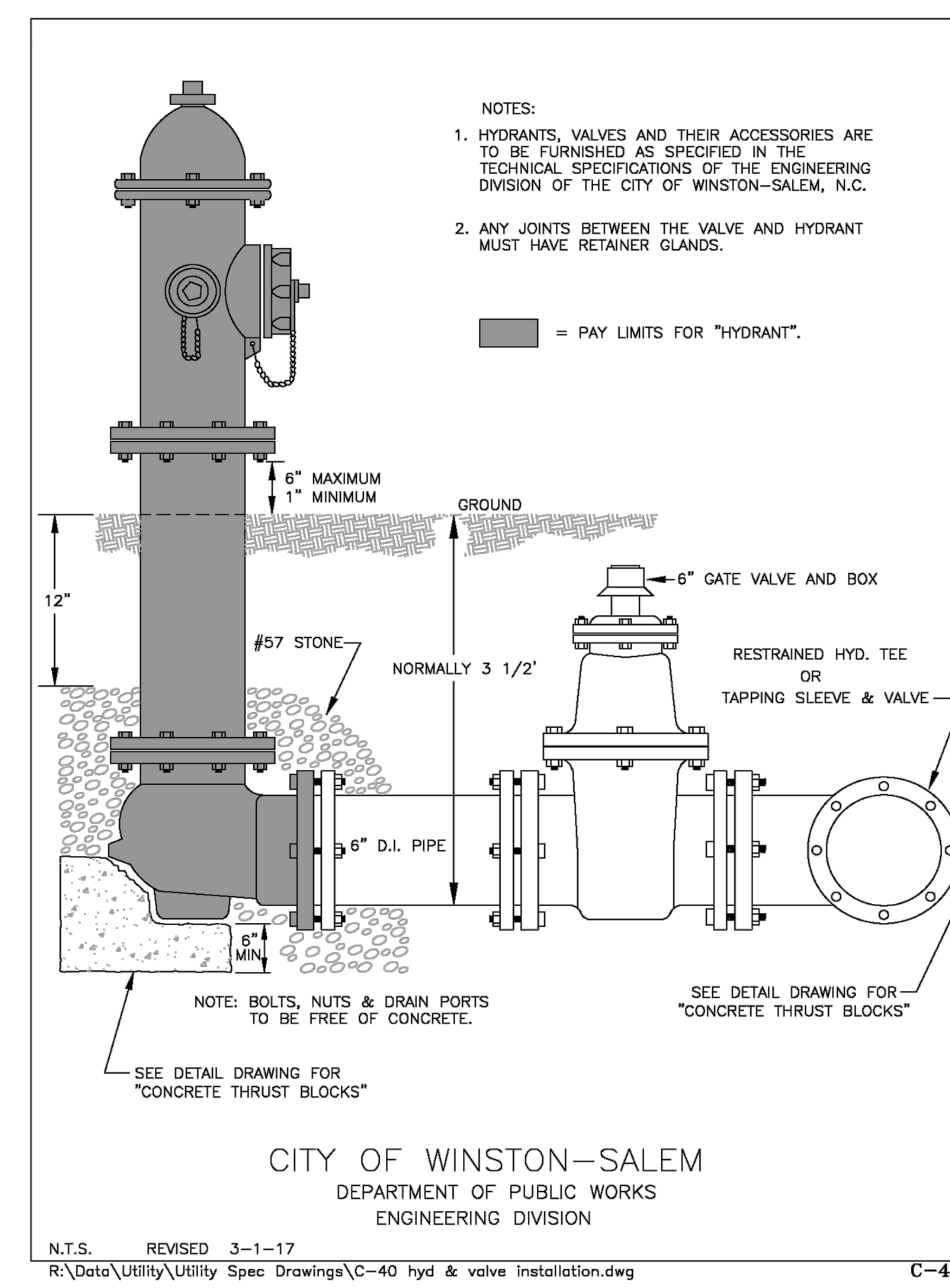

Concrete Thrust Blocks for Horizontal Bends

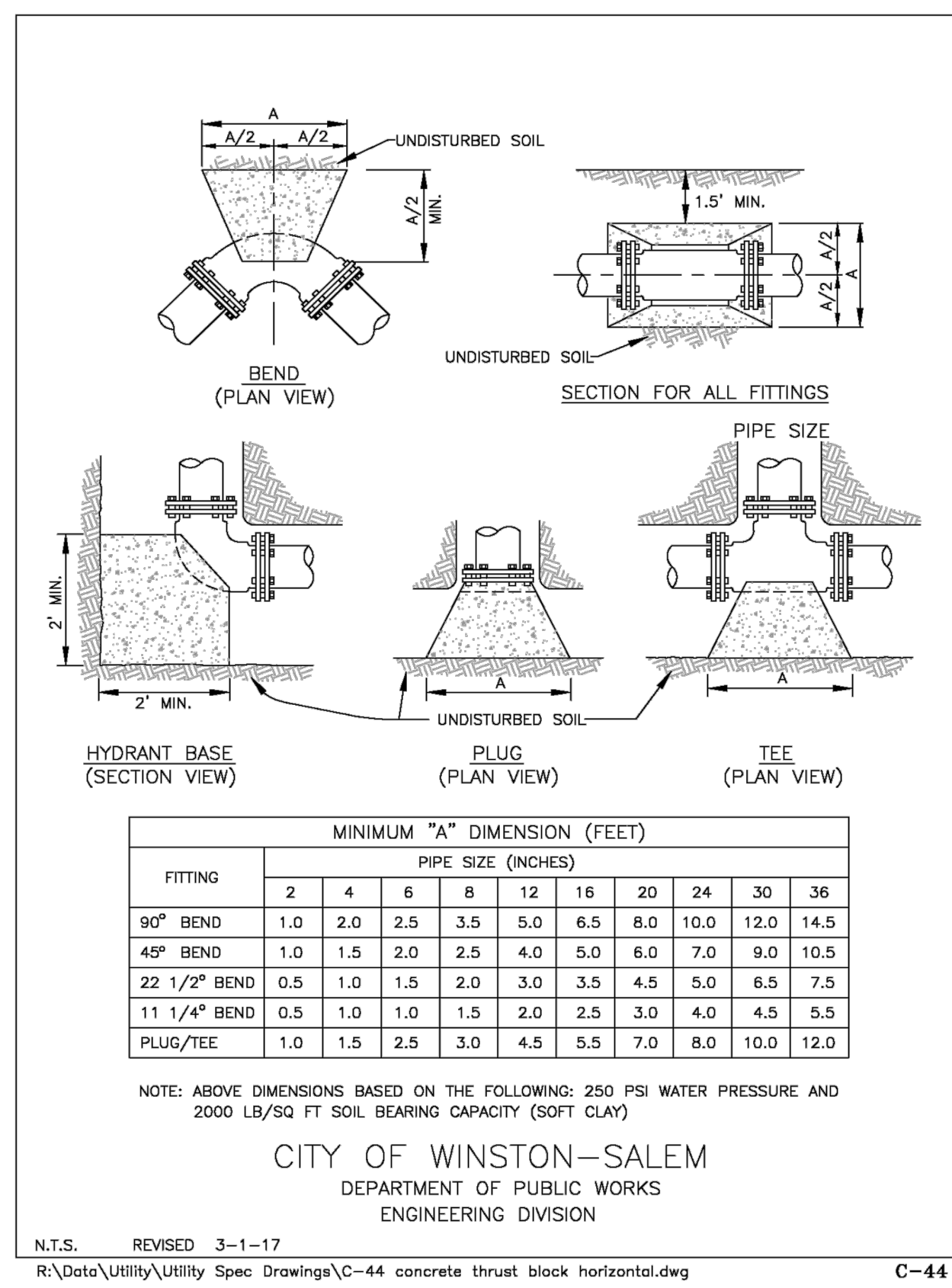

Concrete Thrust Blocks w/ Anchors for Top Vertical Bends

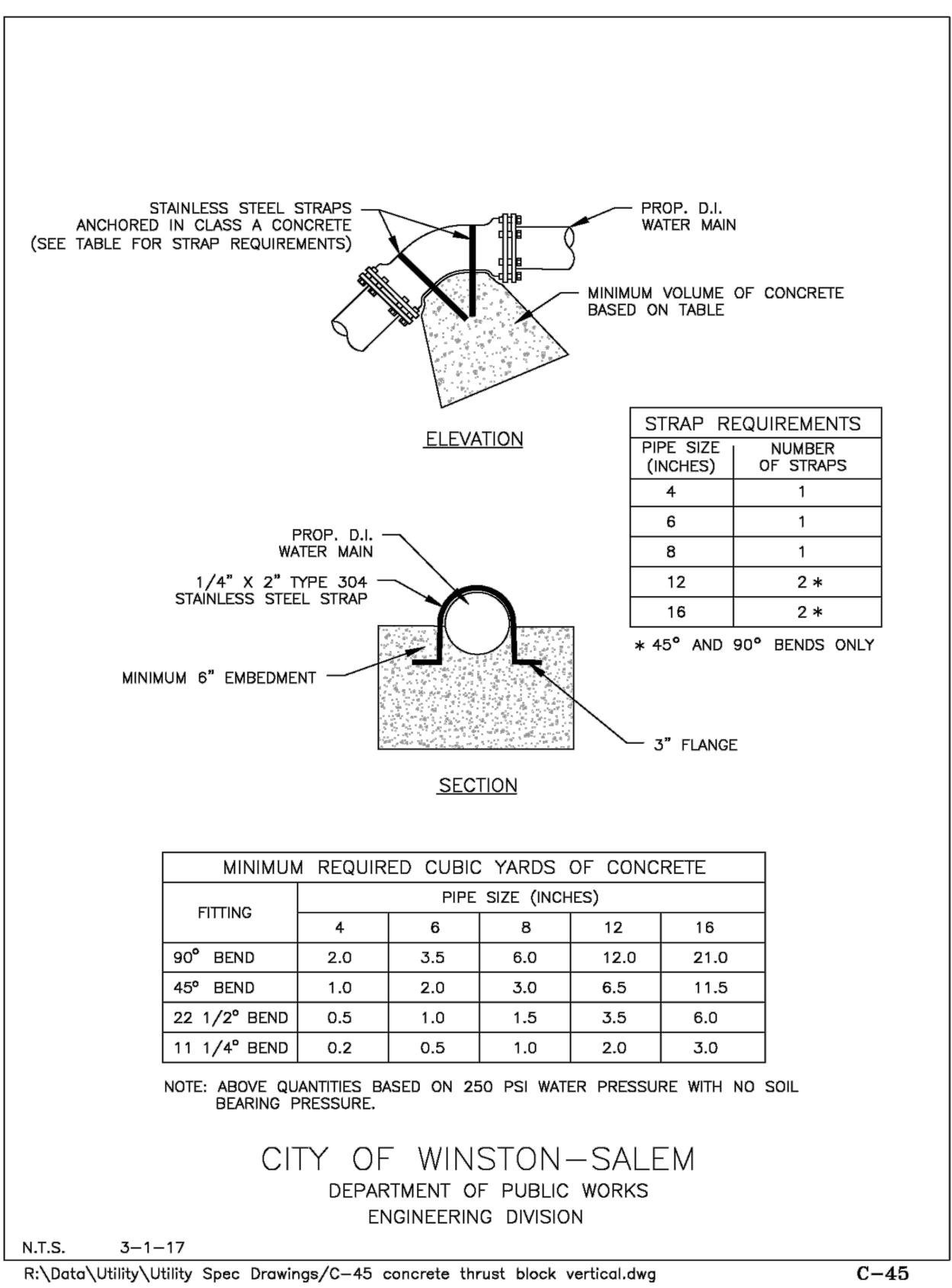

Air Release Valve (Section View)

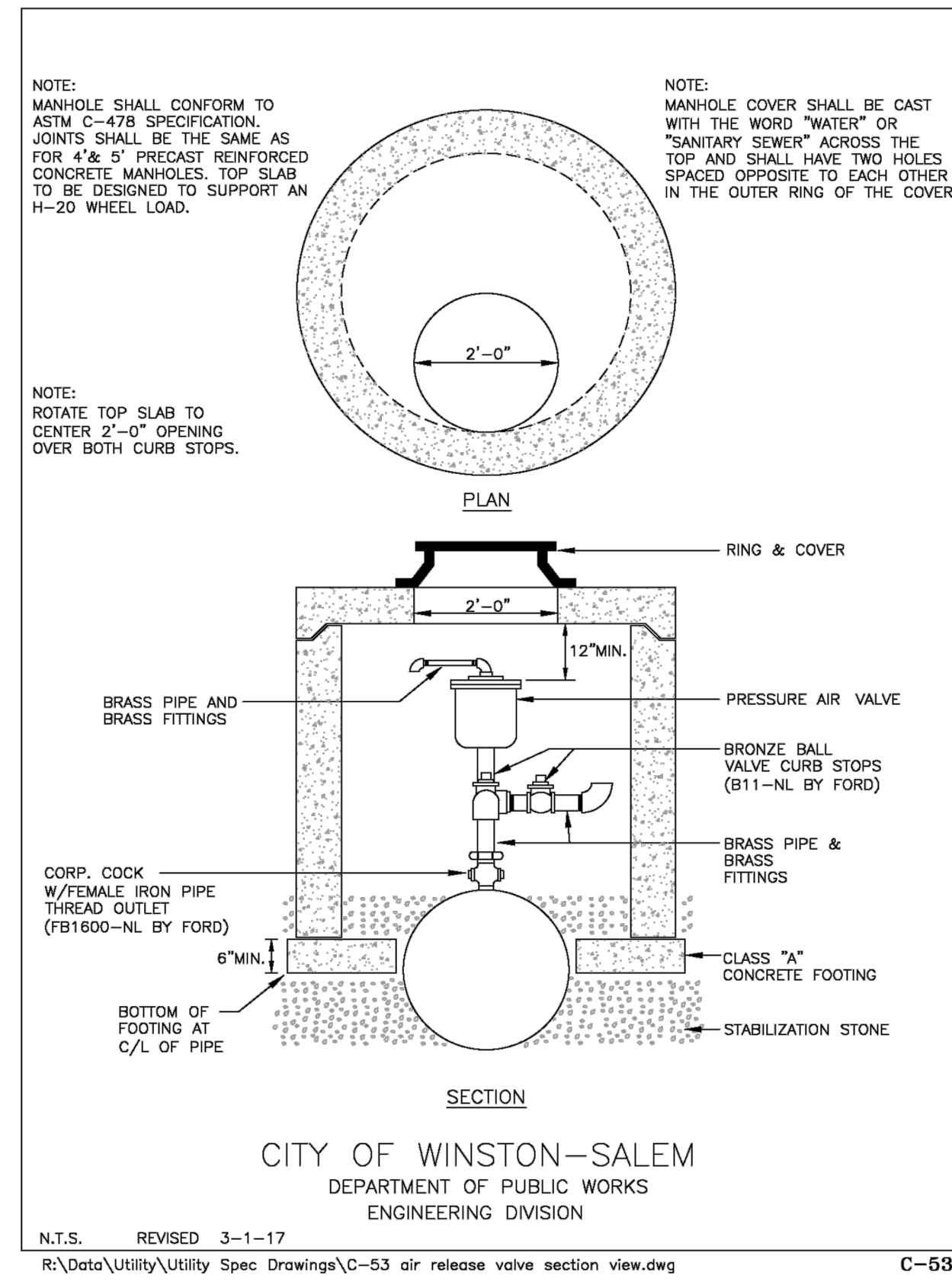

Air Release Valve (Profile View)

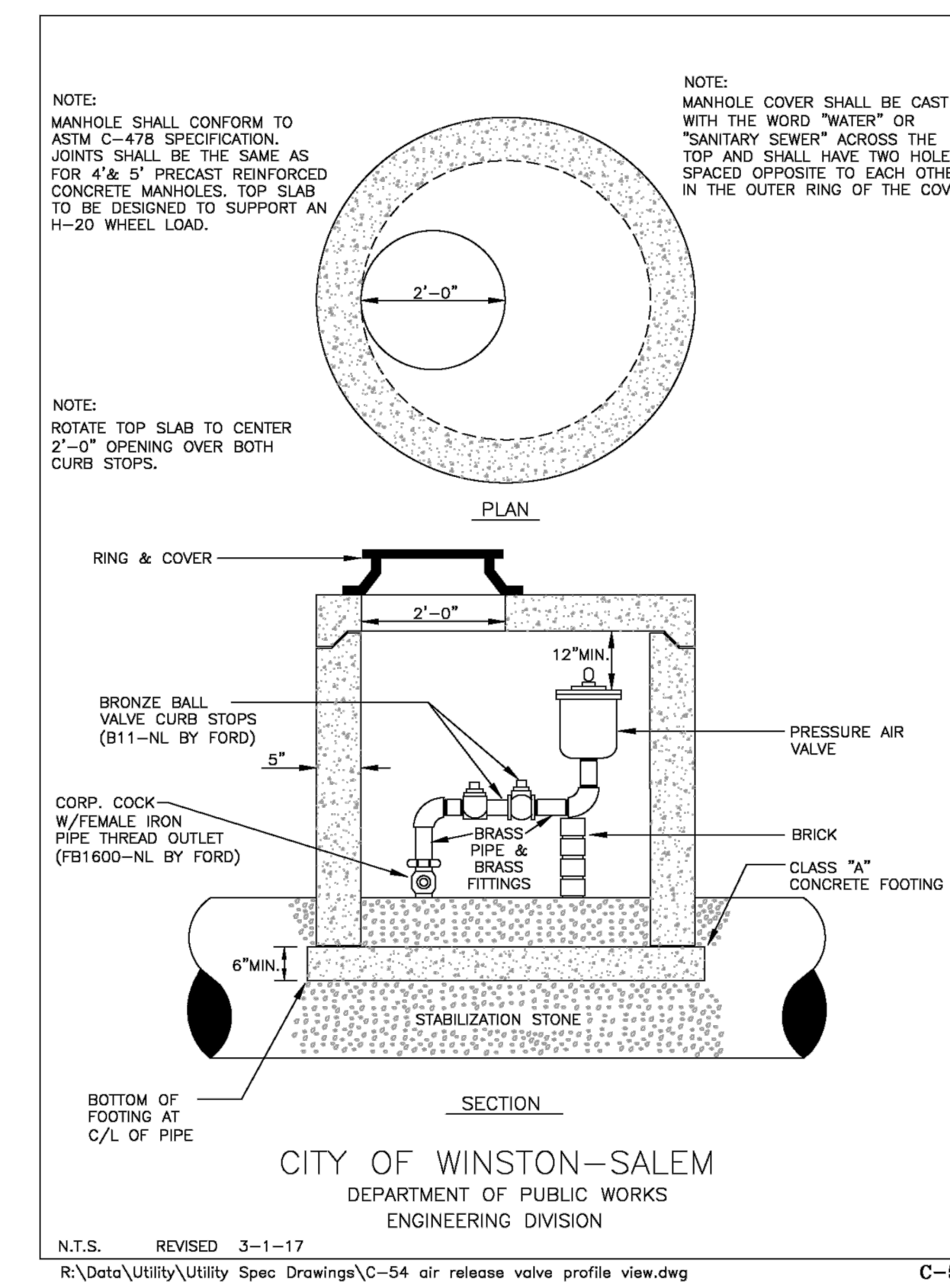

REVISIONS

8/17/99