

**This electronic collection of documents is provided
for the convenience of the user
and is Not a Certified Document –**

**The documents contained herein were originally issued
and sealed by the individuals whose names and license
numbers appear on each page, on the dates appearing
with their signature on that page.**

**This file or an individual page
shall not be considered a certified document.**

8/23/99



PROJ. REFERENCE NO.
B-5327

SHEET NO.
X-1

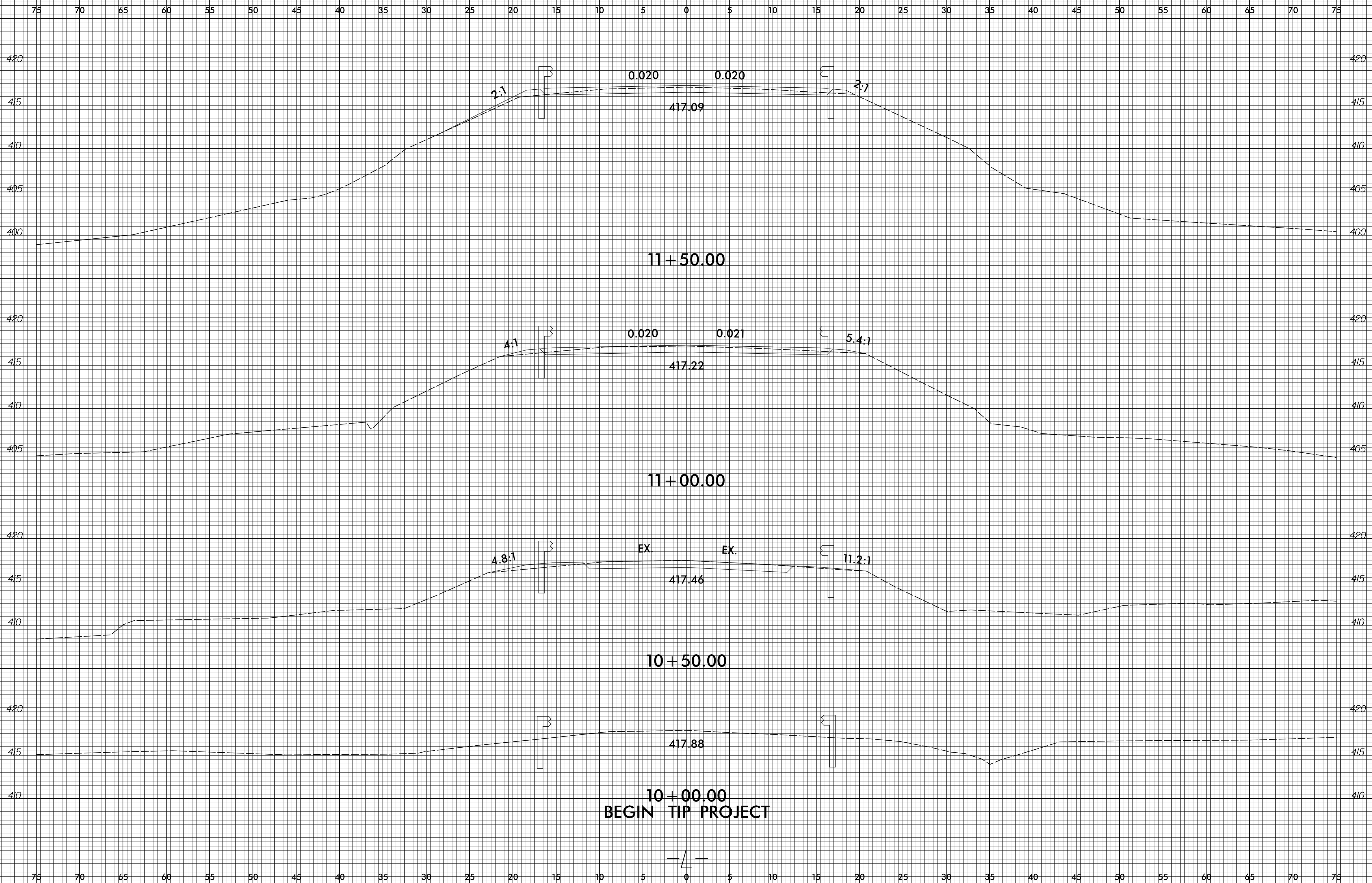

4/12/2017
P:\Regdga\Bcr\qcr\qcrModeling\B5327_rdy_xpl.dgn
PCA ENGINEERING, INC.

75 70 65 60 55 50 45 40 35 30 25 20 15 10 5 0 5 10 15 20 25 30 35 40 45 50 55 60 65 70 75

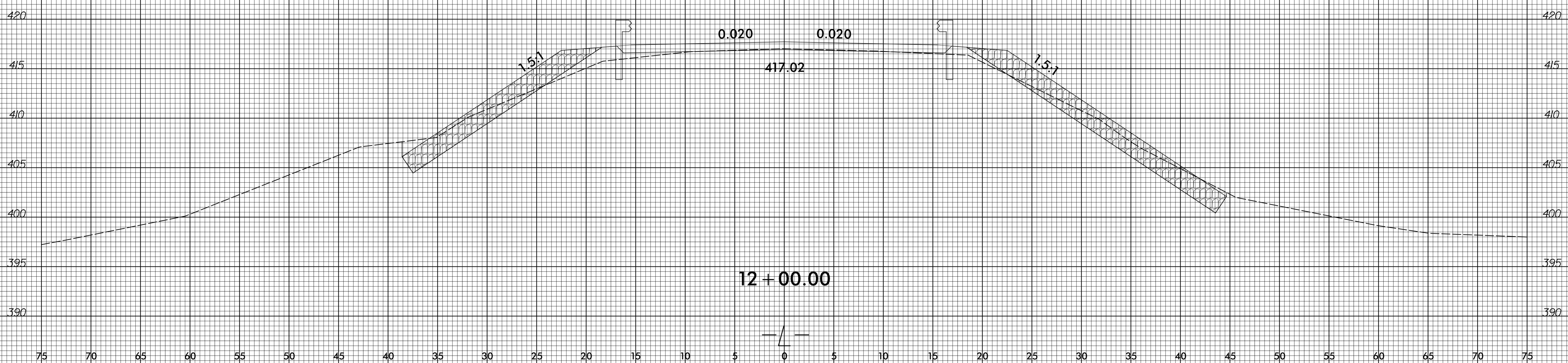
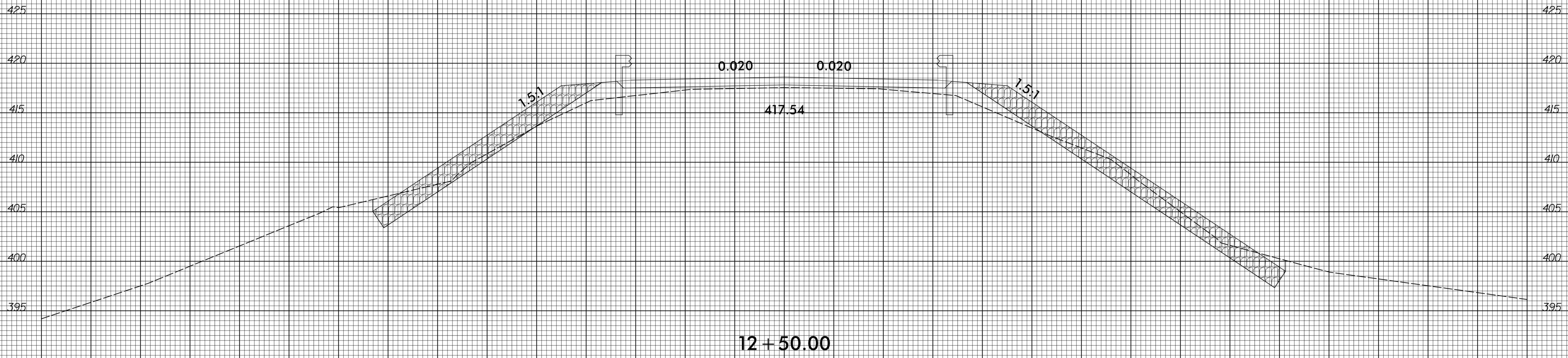

8/23/99

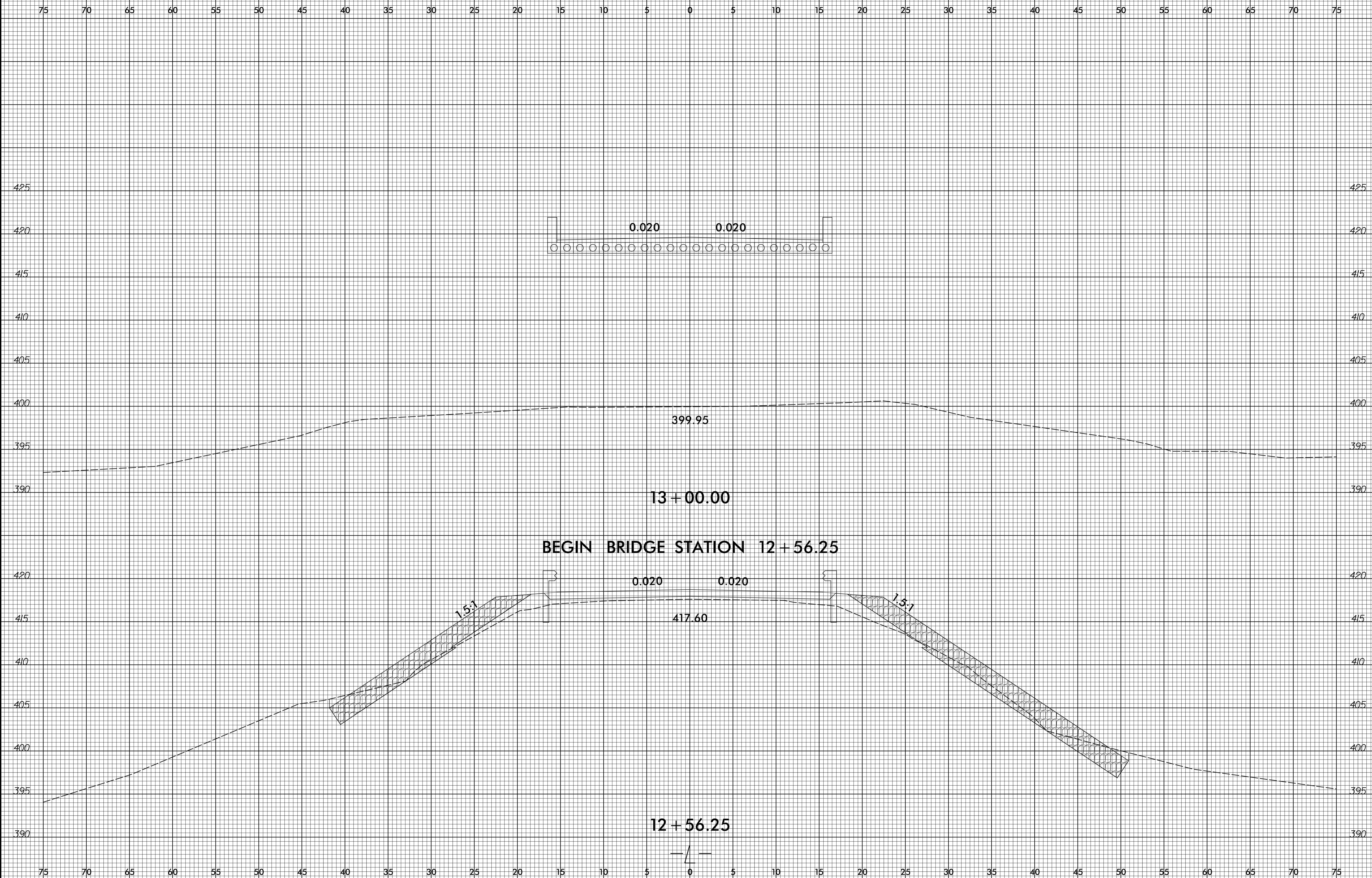

4/24/2017
P:\Projects\B-5327\qcr\qcrModeling\B5327_rfdj_xp1.dgn
PCA ENGINEERING, INC.

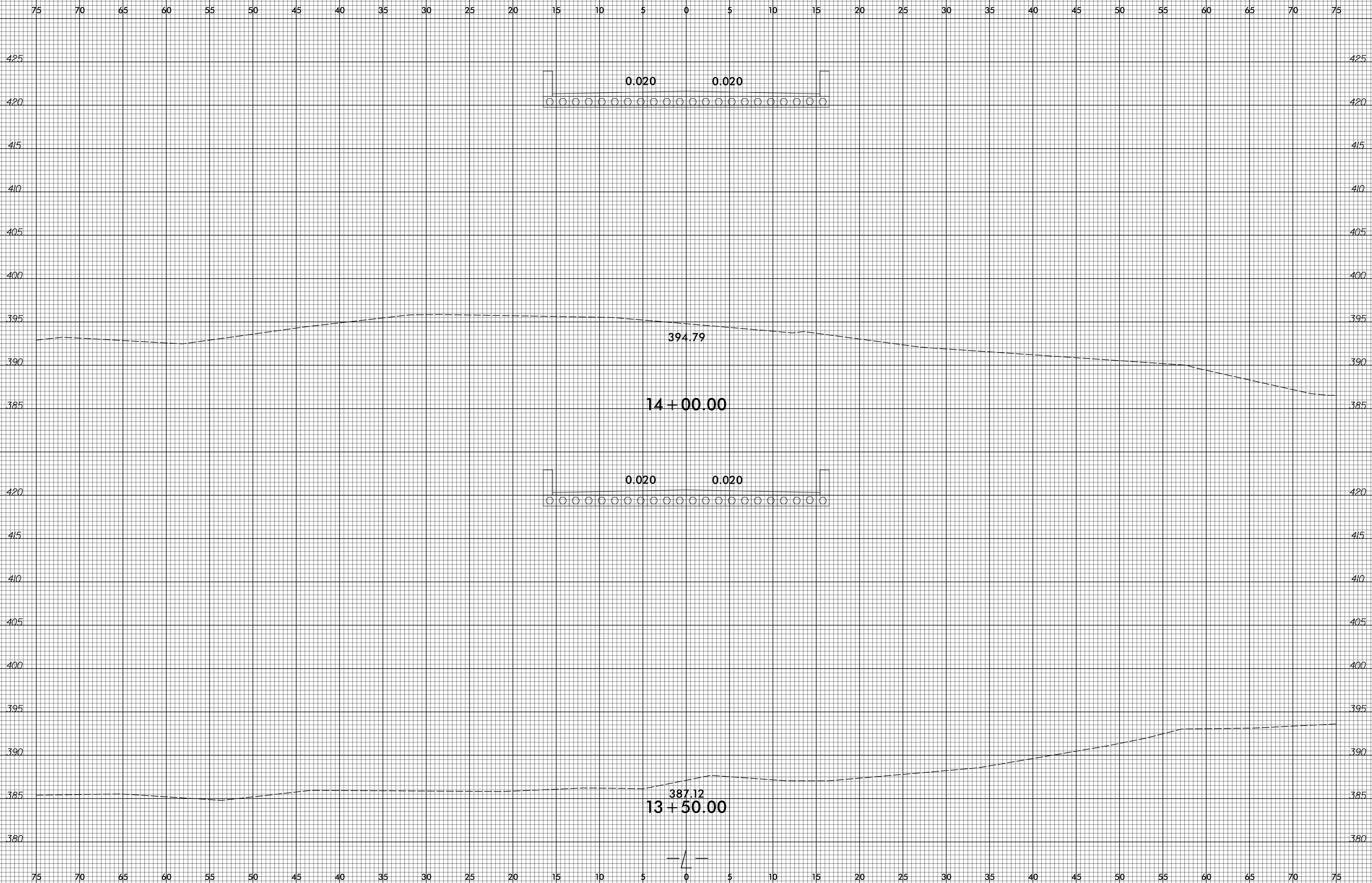

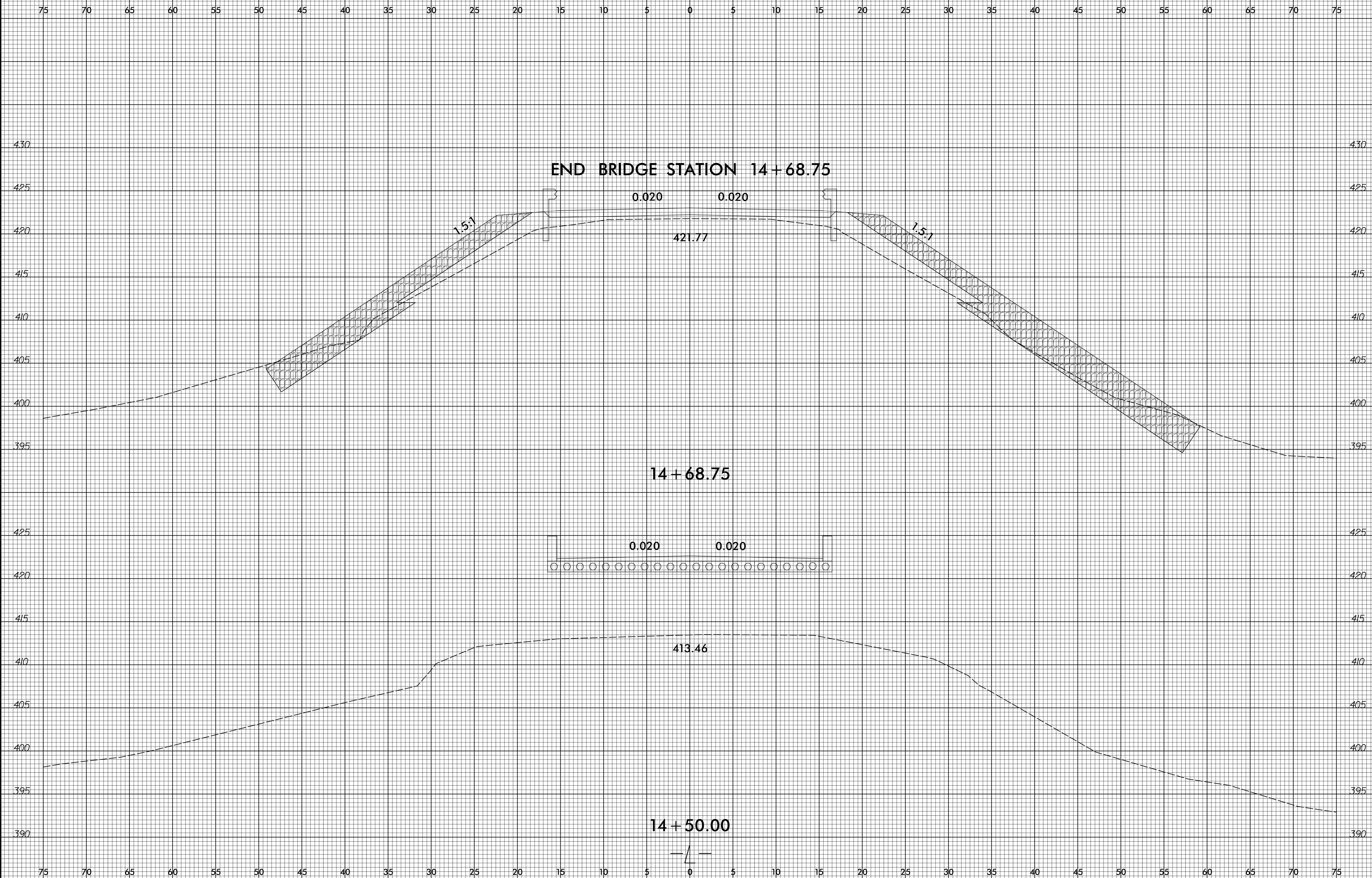

8/23/99

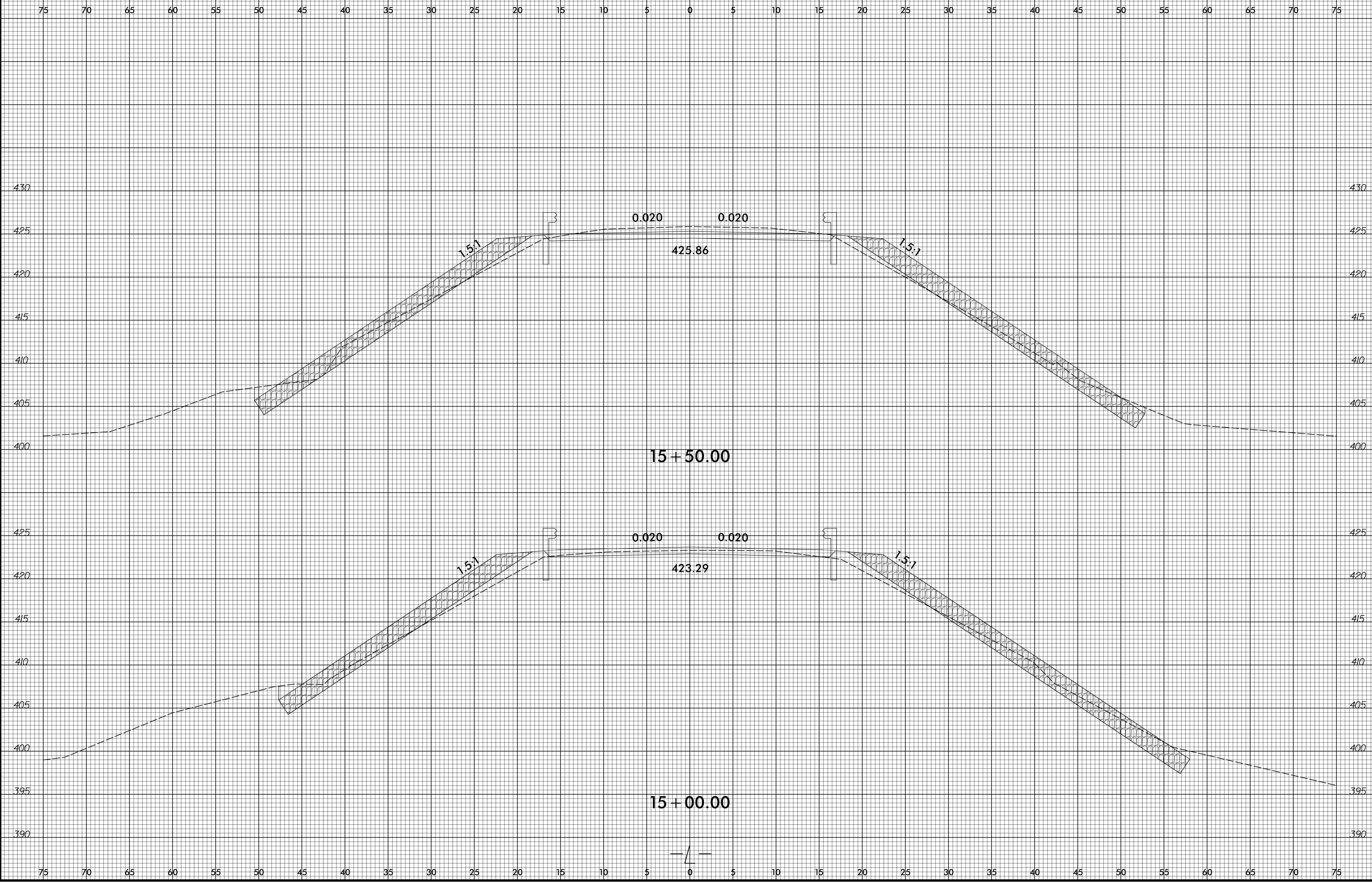

4/12/2017
P:\Regisqa\Borcr\qcr\qcrModeling\B5327_rndj_xpl_1.dgn
PCA ENGINEERING, INC.

8/23/99

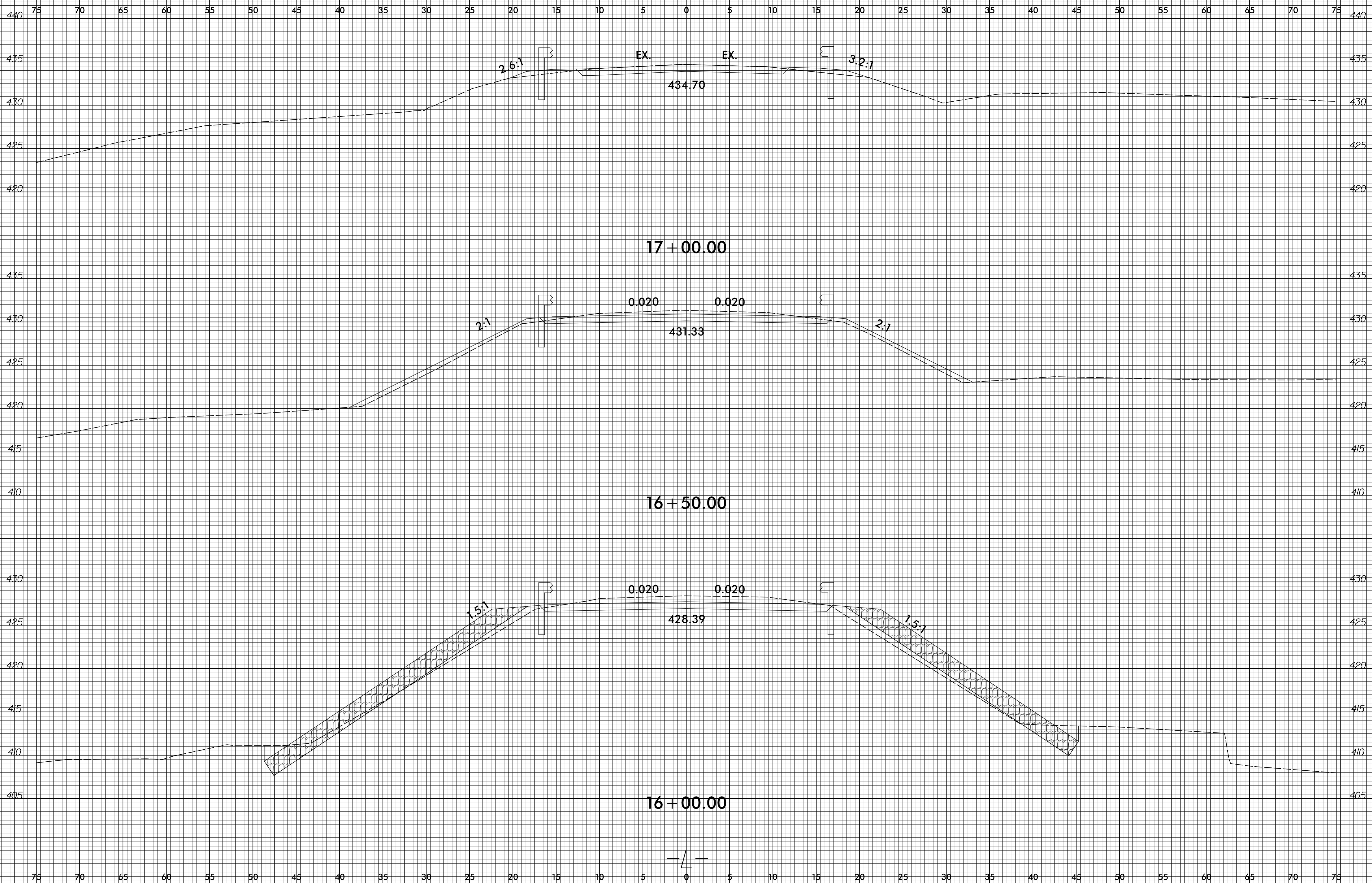

4/12/2017
P:\Regisra\Bcr\qcr\qcr\Mode\ing\b5327_rdl_xpl.dgn
PCA ENGINEERING, INC.

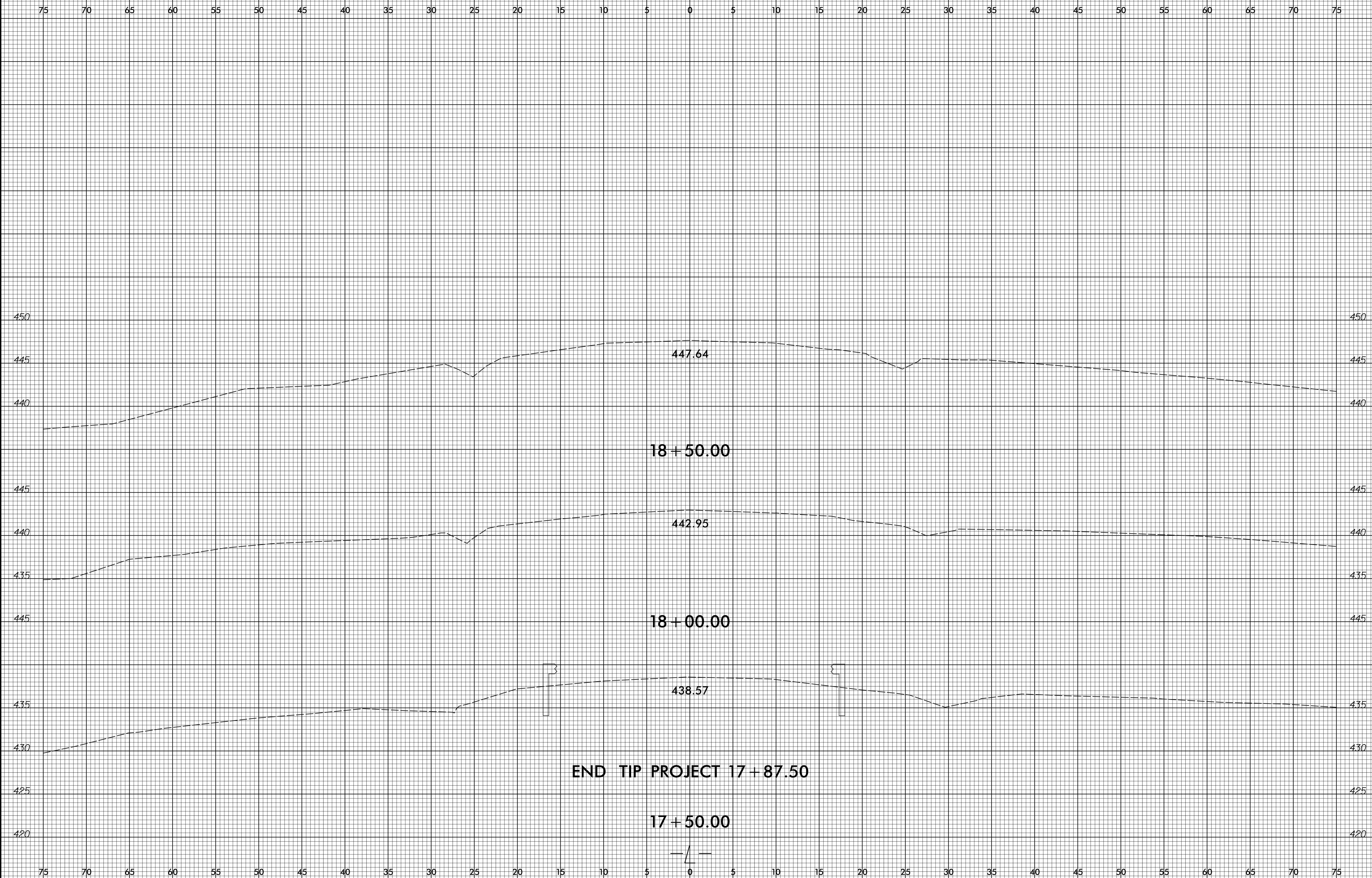

END TIP PROJECT 17+87.50