

**This electronic collection of documents is provided
for the convenience of the user
and is Not a Certified Document –**

**The documents contained herein were originally issued
and sealed by the individuals whose names and license
numbers appear on each page, on the dates appearing
with their signature on that page.**

**This file or an individual page
shall not be considered a certified document.**

4/12/2017
 P:\TIP\Projects-B\B5348\Traffic\Signing\CADD\PM\B-5348_PMP_1.dgn
 Jstacy@dnns

T.I.P.: B-5348

CONTRACT: C203946

**STATE OF NORTH CAROLINA
 DEPARTMENT OF TRANSPORTATION**

**PAVEMENT MARKING PLAN
 ORANGE COUNTY**

LOCATION: BRIDGE NO. 85 OVER A PHILS CREEK ON SR 1005 (OLD GREENSBORO RD)

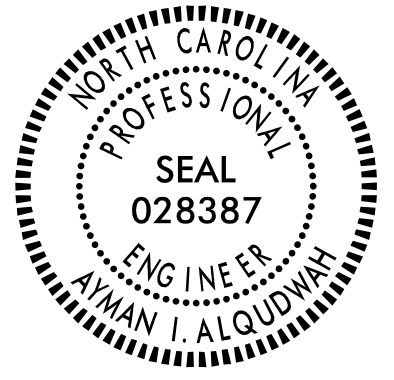
PROJECT REFERENCE NO. B-5348	SHEET NO. PMP - 1
APPROVED: <i>Ayman Alqudwah</i> F32AC5CAF969472	
DATE: 4/12/2017	
SEAL 	
DOCUMENT NOT CONSIDERED FINAL UNLESS ALL SIGNATURES COMPLETED	

ROADWAY STANDARD DRAWING

THE FOLLOWING ROADWAY STANDARDS AS APPEAR IN "ROADWAY STANDARD DRAWINGS" - PROJECT SERVICES UNIT - N.C. DEPARTMENT OF TRANSPORTATION - RALEIGH, N.C., DATED JANUARY 2012 ARE APPLICABLE TO THIS PROJECT AND BY REFERENCE HEREBY ARE CONSIDERED A PART OF THESE PLANS:

STD. NO.	TITLE
1205.01	PAVEMENT MARKINGS - LINE TYPES AND OFFSETS
1205.02	PAVEMENT MARKINGS - TWO-LANE AND MULTILANE ROADWAYS
1261.01	GUARDRAIL AND BARRIER DELINEATORS - INSTALLATION SPACING
1261.02	GUARDRAIL AND BARRIER DELINEATORS - TYPES AND MOUNTING
1262.01	GUARDRAIL END DELINEATION

PAVEMENT MARKING SCHEDULE

SYMBOL	DESCRIPTION
TA	THERMOPLASTIC(4", 90 MILS) WHITE EDGELINE
TI	THERMOPLASTIC(4", 120 MILS) YELLOW DOUBLE CENTER

GENERAL NOTES

THE FOLLOWING GENERAL NOTES APPLY AT ALL TIMES FOR THE DURATION OF THE CONSTRUCTION PROJECT, EXCEPT WHEN OTHERWISE NOTED IN THE PLAN, OR DIRECTED BY THE ENGINEER.

- A) INSTALL PAVEMENT MARKINGS AND PAVEMENT MARKERS ON THE FINAL SURFACE AS FOLLOWS:

ROAD NAME	MARKING	MARKER
SR 1005 (OLD GREENSBORO RD)	THERMOPLASTIC	NONE
- B) TIE PROPOSED PAVEMENT MARKING LINES TO EXISTING PAVEMENT MARKING LINES.
- C) REMOVE/REPLACE ANY CONFLICTING/DAMAGED PAVEMENT MARKINGS AND MARKERS.
- D) PASSING ZONES WILL BE DETERMINED IN THE FIELD AND MUST BE APPROVED BY THE ENGINEER.

PAVEMENT MARKING DETAIL

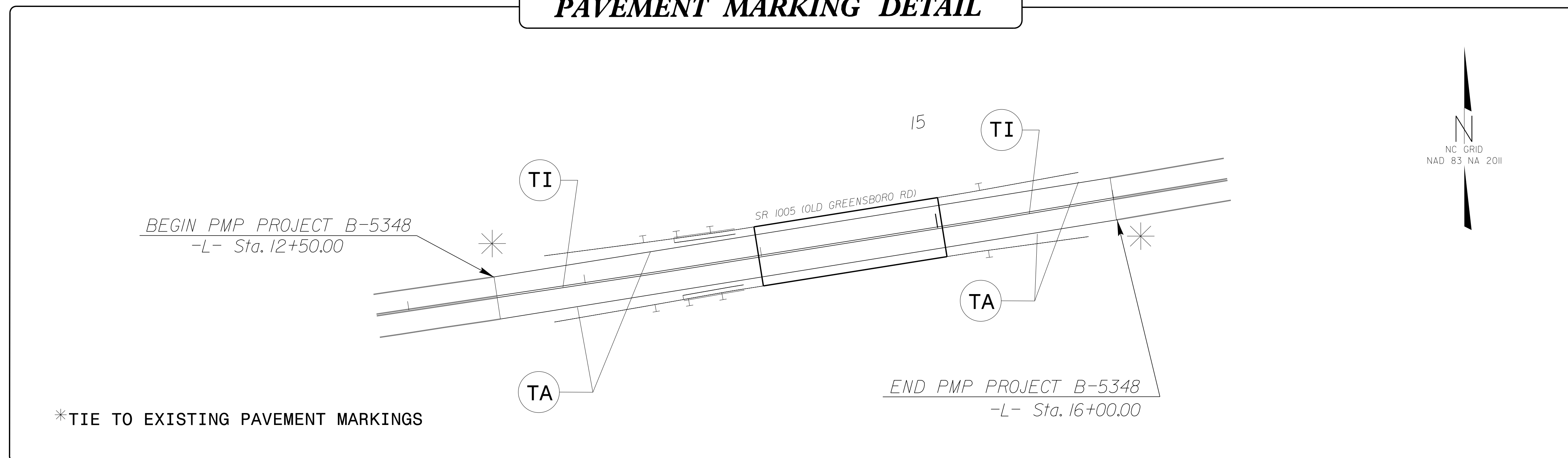

PLAN PREPARED BY: N.C.D.O.T. SIGNING AND DELINEATION UNIT

AYMAN ALQUDWAH, P.E. SIGNING & DELINEATION REGIONAL ENGINEER

STACEY W. JOHNS SIGNING & DELINEATION PROJECT DESIGN ENGINEER

