

TYPICAL SECTION A-A  
-L- STA. 150+50 +/-

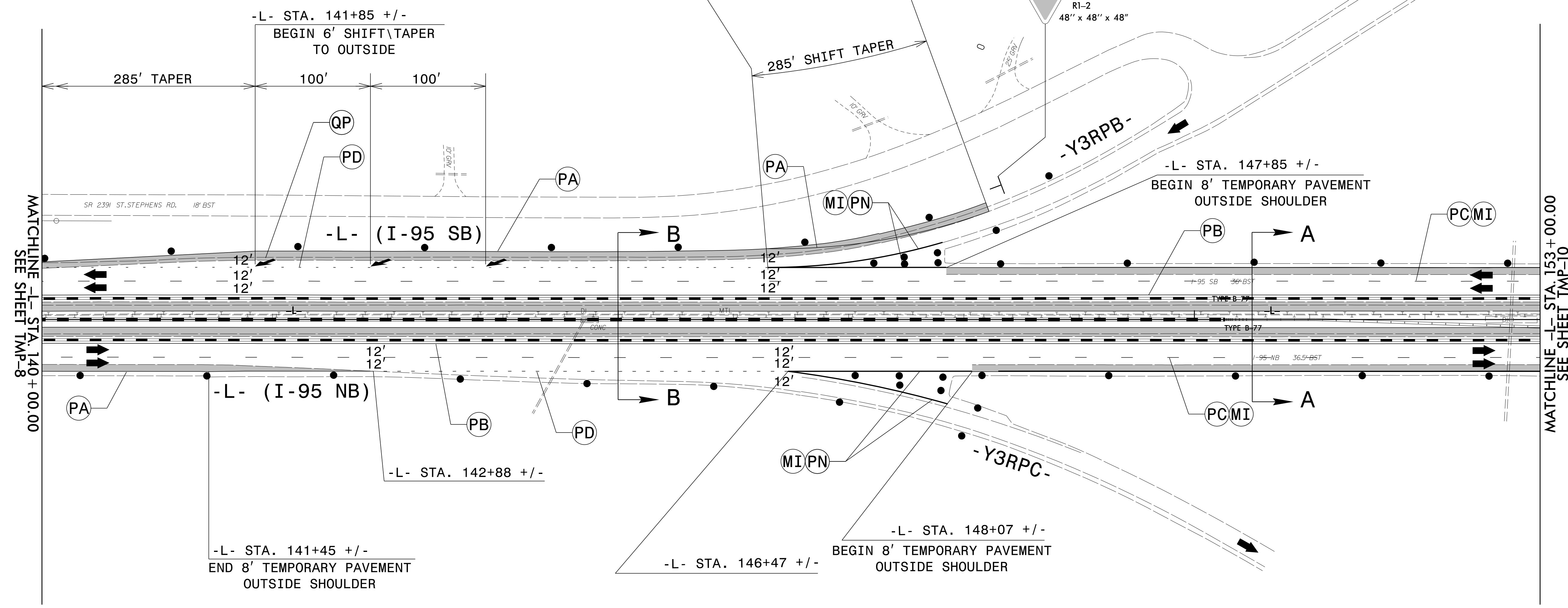

-L- STA. 141+85 +/-  
BEGIN 6' SHIFT/TAPER TO OUTSIDE

-L- STA. 142+88 +/-

-L- STA. 141+45 +/-  
END 8' TEMPORARY PAVEMENT OUTSIDE SHOULDER

-L- STA. 146+47 +/-  
BEGIN 8' TEMPORARY PAVEMENT OUTSIDE SHOULDER

-L- STA. 148+07 +/-  
END 8' TEMPORARY PAVEMENT OUTSIDE SHOULDER

-L- STA. 147+85 +/-  
BEGIN 8' TEMPORARY PAVEMENT OUTSIDE SHOULDER

-L- STA. 146+47 +/-  
END SHIFT TO OUTSIDE SHOULDER

-L- STA. 146+47 +/-  
END 8' TEMPORARY PAVEMENT OUTSIDE SHOULDER

-L- STA. 146+47 +/-  
END SHIFT TO OUTSIDE SHOULDER

-L- STA. 146+47 +/-  
END 8' TEMPORARY PAVEMENT OUTSIDE SHOULDER

-L- STA. 146+47 +/-  
END SHIFT TO OUTSIDE SHOULDER

-L- STA. 146+47 +/-  
END 8' TEMPORARY PAVEMENT OUTSIDE SHOULDER

-L- STA. 146+47 +/-  
END SHIFT TO OUTSIDE SHOULDER

-L- STA. 146+47 +/-  
END 8' TEMPORARY PAVEMENT OUTSIDE SHOULDER

-L- STA. 146+47 +/-  
END SHIFT TO OUTSIDE SHOULDER

-L- STA. 146+47 +/-  
END 8' TEMPORARY PAVEMENT OUTSIDE SHOULDER

-L- STA. 146+47 +/-  
END SHIFT TO OUTSIDE SHOULDER

-L- STA. 146+47 +/-  
END 8' TEMPORARY PAVEMENT OUTSIDE SHOULDER

-L- STA. 146+47 +/-  
END SHIFT TO OUTSIDE SHOULDER

-L- STA. 146+47 +/-  
END 8' TEMPORARY PAVEMENT OUTSIDE SHOULDER

-L- STA. 146+47 +/-  
END SHIFT TO OUTSIDE SHOULDER

-L- STA. 146+47 +/-  
END 8' TEMPORARY PAVEMENT OUTSIDE SHOULDER

-L- STA. 146+47 +/-  
END SHIFT TO OUTSIDE SHOULDER

-L- STA. 146+47 +/-  
END 8' TEMPORARY PAVEMENT OUTSIDE SHOULDER

MATCHLINE -L- STA. 140+00.00  
SEE SHEET TMP-8

MATCHLINE -L- STA. 153+00.00  
SEE SHEET TMP-10

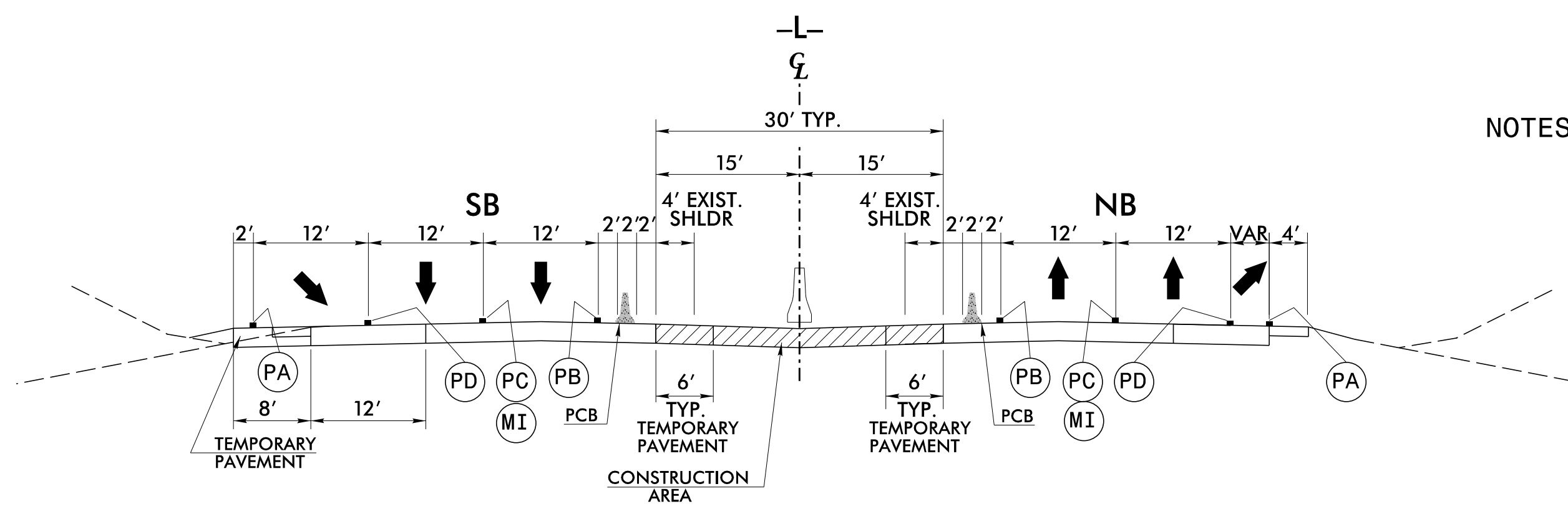

TYPICAL SECTION B-B  
-L- STA. 145+00 +/-

NOTES: SEE SHEET TMP-1A FOR PAVEMENT MARKING SCHEDULE.

DOCUMENT NOT CONSIDERED FINAL  
UNLESS ALL SIGNATURES COMPLETED

**WETHERILL ENGINEERING**

1223 Jones Franklin Rd.  
Raleigh, N.C. 27606  
License No. F-0377  
Bus: 919 851 8077  
Fax: 919 851 8107

TRANSPORTATION PLANNING/DESIGN - BRIDGE/STRUCTURE DESIGN  
CIVIL/SITE DESIGN - GIS/GPS - CONSTRUCTION OBSERVATION

APPROVED: 7/6/2017

DATE:

SEAL

Bob A. May

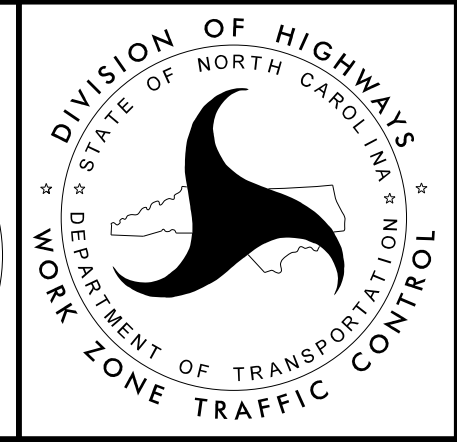

PHASE I  
DETAIL

7/6/2017  
P:\2017\I-5786\TrafficControl\TCPV\I-5786\_TC\_TMP\_PSH\_09.dgn  
User:skennedy