

**NOTES**

- OVERLAP SAW CUTS AT CORNERS AND INTERSECTION POINTS TO ENSURE UNIFORM SAW SLOT DEPTH.
- MAINTAIN 12" SPACING BETWEEN LOOP WIRE TAIL SECTIONS.
- WIRE LOOPS CONNECTED TO THE SAME DETECTOR IN SERIES.
- LOCATE LOOPS IN CENTER OF LANES UNLESS OTHERWISE SHOWN ON PLANS.
- USE A SERIES OF ONE INCH PIECES OF BACKER ROD SPACED ONE FOOT APART ALONG THE ENTIRE LENGTH OF THE FEEDER SLOT AND LOOP SAW SLOT.
- CONSULT LOOP SEALANT MANUFACTURER TO DETERMINE CURING TIME REQUIRED PRIOR TO MILLING.
- REFER TO STANDARD DRAWING 1725.01 SHEETS 2 AND 3 FOR ADDITIONAL REQUIREMENTS.

**SAW SLOT DEPTH CHART**  
ASSUMING 2" MILLING DEPTH

DEPTH (IN)	MAX NO. OF WIRE LAYERS				
	2	3	4	5	6
SAW SLOT DEPTH	4.0	4.5	5.0	5.0	5.0
MINIMUM TOTAL ASPHALT DEPTH REQUIRED	5.0	5.5	6.0	6.0	6.0

**LOOP WIRE TWISTING METHOD**

INCORRECT WAY TO TWIST WIRE



CORRECT WAY TO TWIST WIRE

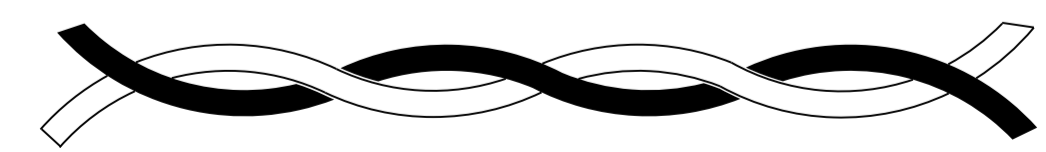

**CONVENTIONAL 4-SIDED LOOP**

I-5852B SIG-2

**SAW CUT OPTIONS**

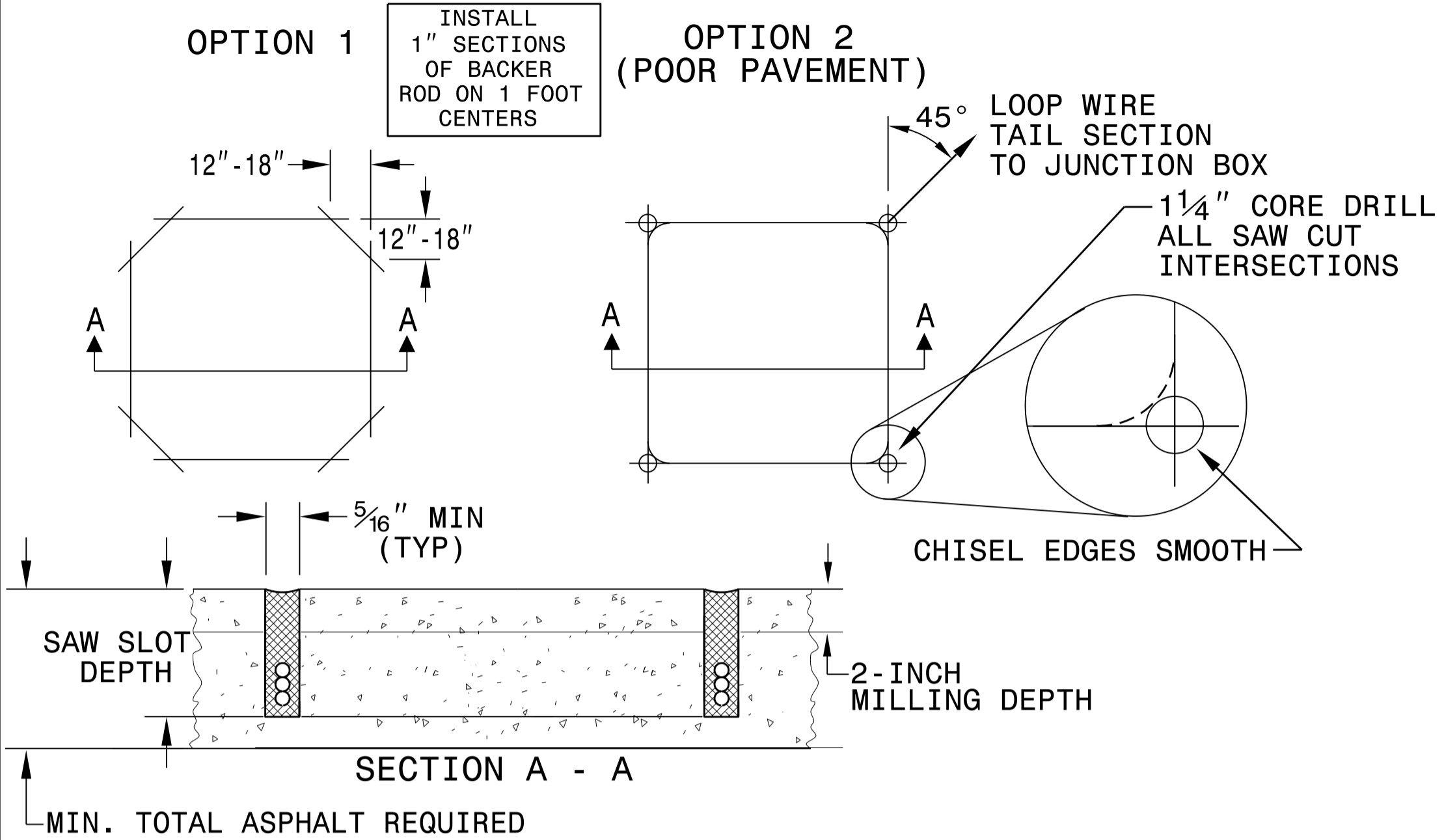

**LOOP WINDING METHOD**

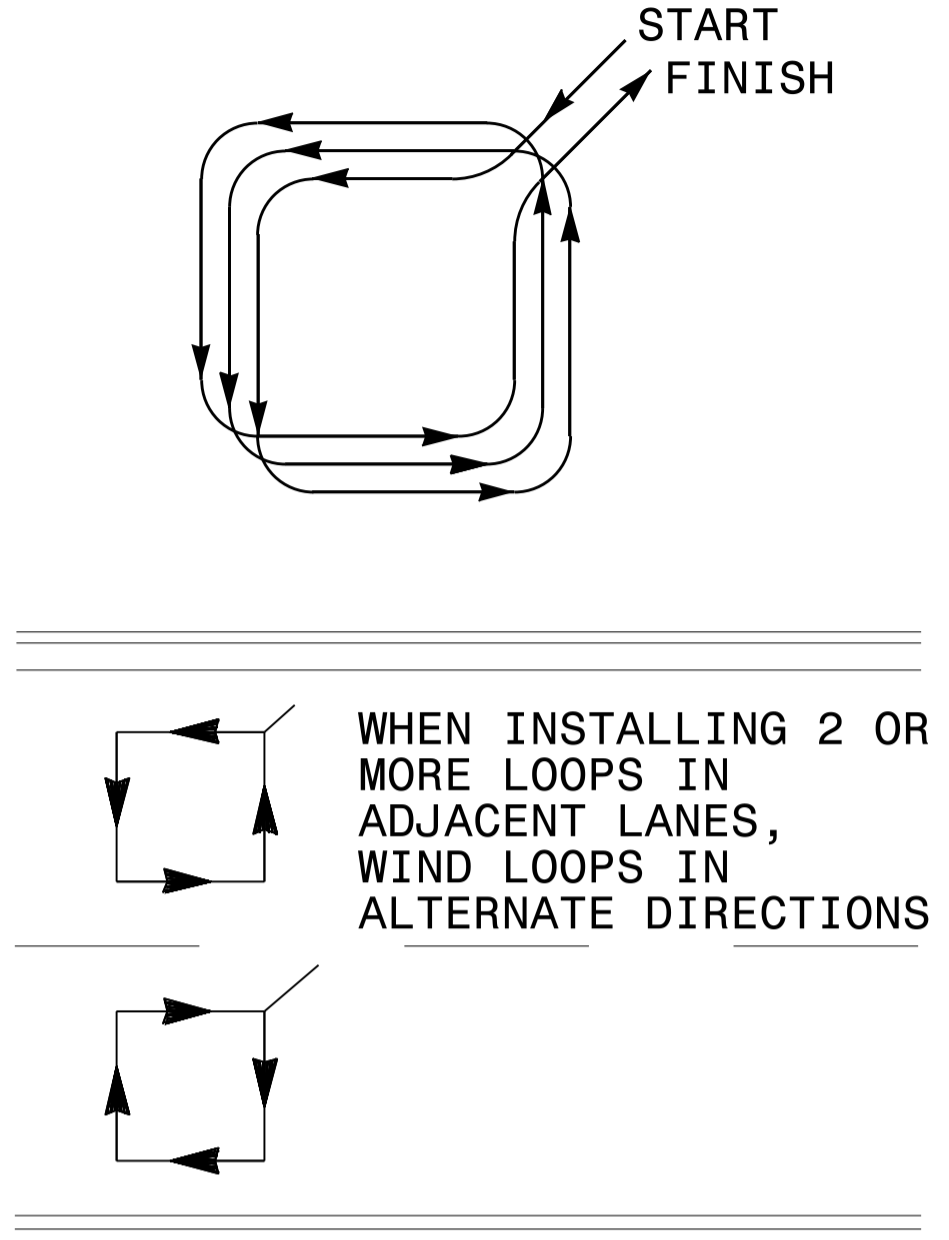

**QUADRUPOLE LOOP**

**SAW CUT OPTIONS**

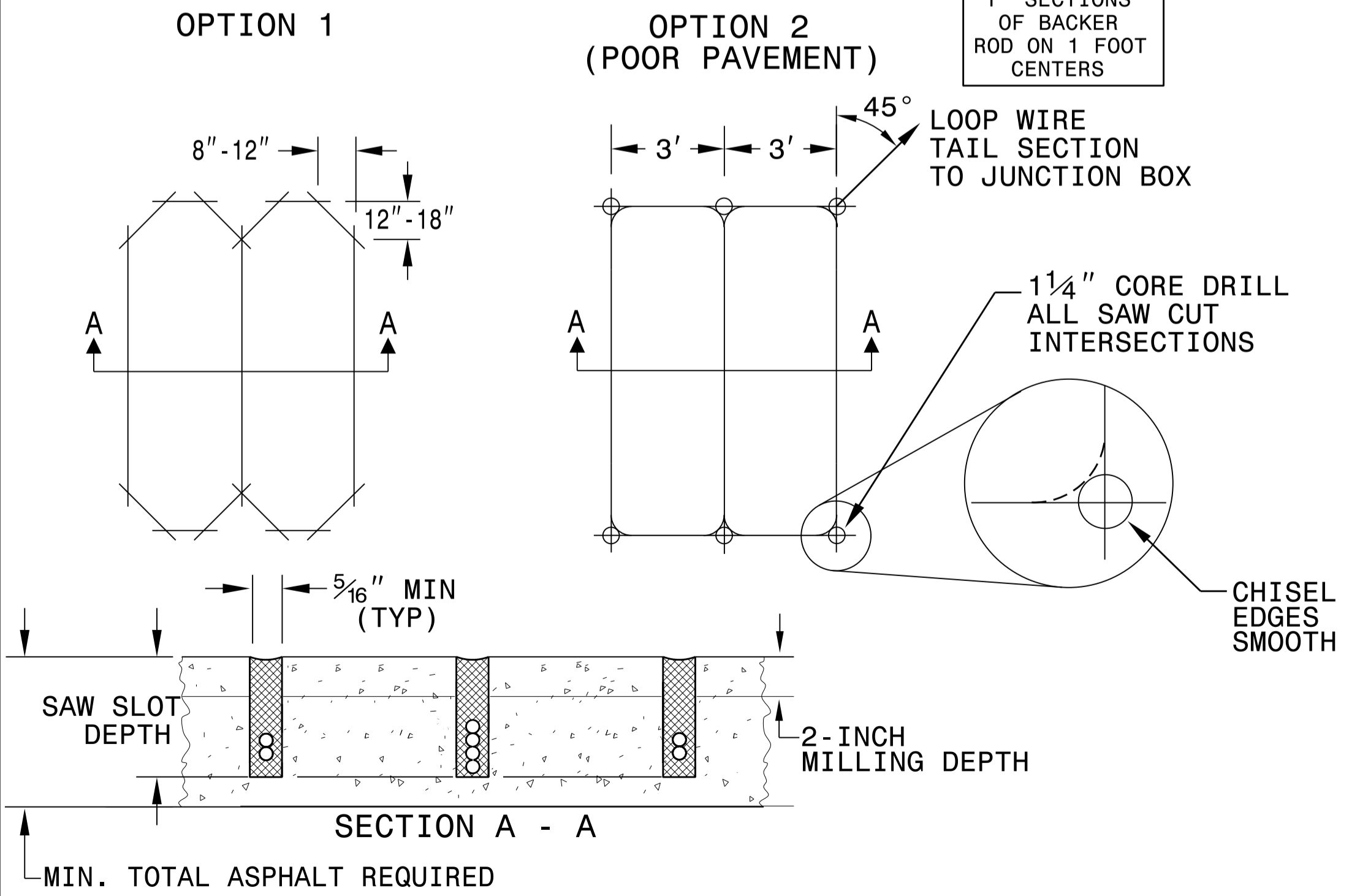

**LOOP WINDING METHOD**

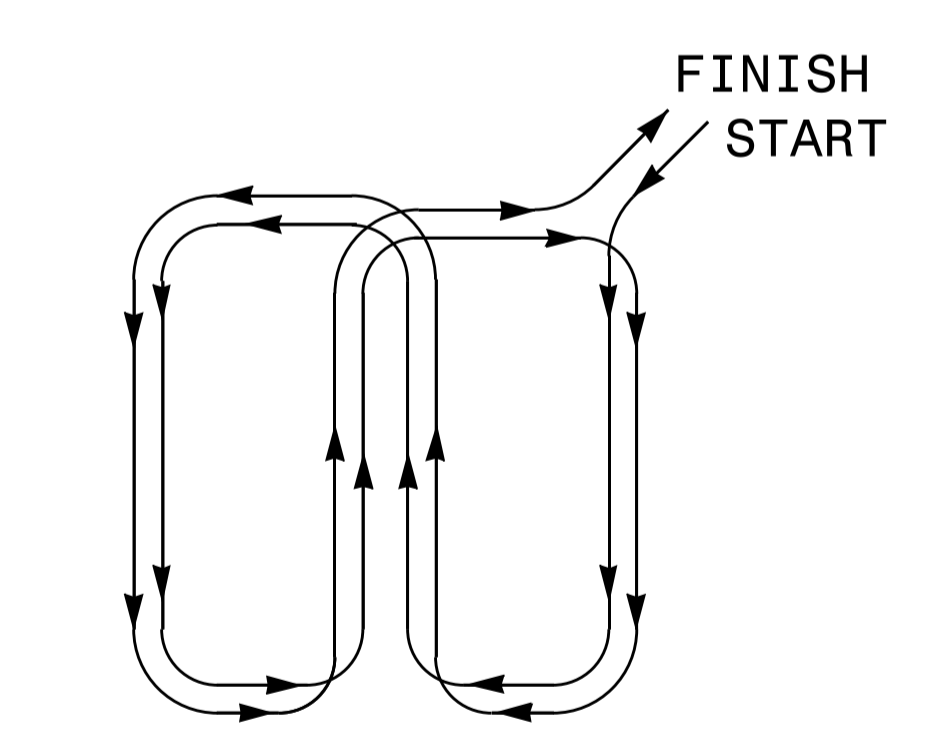

**REVISIONS**

1. REMOVED TWISTING NOTES FROM TAIL SECT. TO JUNCTION BOX. 2/26/08 MWH
2. REVISED SECTION A - A DETAILS. 6/29/15 JTP

