

**This electronic collection of documents is provided
for the convenience of the user
and is Not a Certified Document –**

**The documents contained herein were originally issued
and sealed by the individuals whose names and license
numbers appear on each page, on the dates appearing
with their signature on that page.**

**This file or an individual page
shall not be considered a certified document.**

**PAVEMENT
MARKING SCHEDULE**

SYMBOL	DESCRIPTION	FINAL PAVEMENT MARKINGS
		COLD APPLIED PLASTIC (6") Type2 - Permanent High Performance
C6	WHITE EDGELINE	
C7	YELLOW EDGELINE	
CJ	10 FT. WHITE SKIP	
		THERMOPLASTIC(4", 90 MILS)
TA	WHITE EDGELINE	
TB	YELLOW EDGELINE	
		THERMOPLASTIC(4", 120 MILS)
T8	2 FT. - 6 FT./SP WHITE MINISKIP	
TD	3 FT. - 9 FT./SP WHITE MINISKIP	
TE	WHITE SOLID LANE LINE	
TI	YELLOW DOUBLE CENTER	
		THERMOPLASTIC(6", 90 MILS)
T6	WHITE EDGELINE	
T7	YELLOW EDGELINE	
		THERMOPLASTIC(6", 120 MILS)
TJ	10 FT. WHITE SKIP	
TK	3 FT. - 9 FT./SP WHITE MINISKIP	
		THERMOPLASTIC(12", 90 MILS)
TS	WHITE GORELINE	
TV	YELLOW DIAGONAL	
		THERMOPLASTIC(24", 120 MILS)
T2	WHITE STOPBAR	
		THERMOPLASTIC PAVEMENT MARKING SYMBOLS (90 MILS)
UA	LEFT TURN ARROW	
UC	STRAIGHT ARROW	
UE	COMBO.STRAIGHT/RIGHT	
UG	COMBO LEFT/RIGHT/STRAIGHT	
UP	MERGE ARROW	
UQ	RAMP ARROW SYMBOL	
		PERMANENT RAISED PAVEMENT MARKER
MA	YELLOW & YELLOW	
MB	CRYSTEL & RED	

12/22/2016
 P:\2015\NR-5719\TrafficControl\TC\CPVr5719_TC_PMP_PSH_01.dgn
 User:skennedy

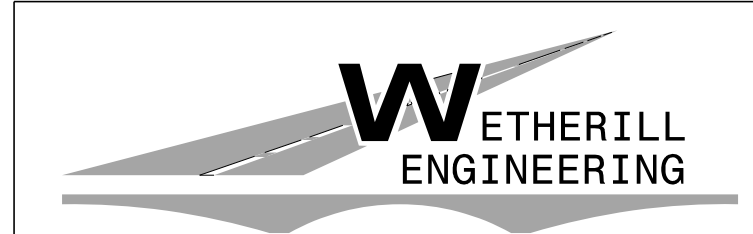

1223 Jones Franklin Rd.
 Raleigh, N.C. 27606
 License No. F-0377
 Bus: 919 851 8077
 Fax: 919 851 8107

TRANSPORTATION PLANNING/DESIGN - BRIDGE/STRUCTURE DESIGN
 CIVIL/SITE DESIGN - GIS/GPS - CONSTRUCTION OBSERVATION

**DOCUMENT NOT CONSIDERED FINAL
 UNLESS ALL SIGNATURES COMPLETED**

APPROVED: _____
 DATE: _____

SEAL

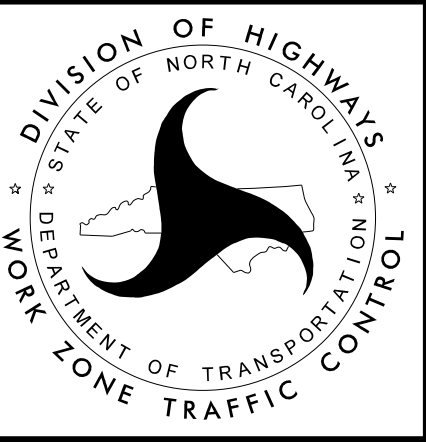

**R-5719 AREA 2
 PAVEMENT MARKING
 SCHEDULE**

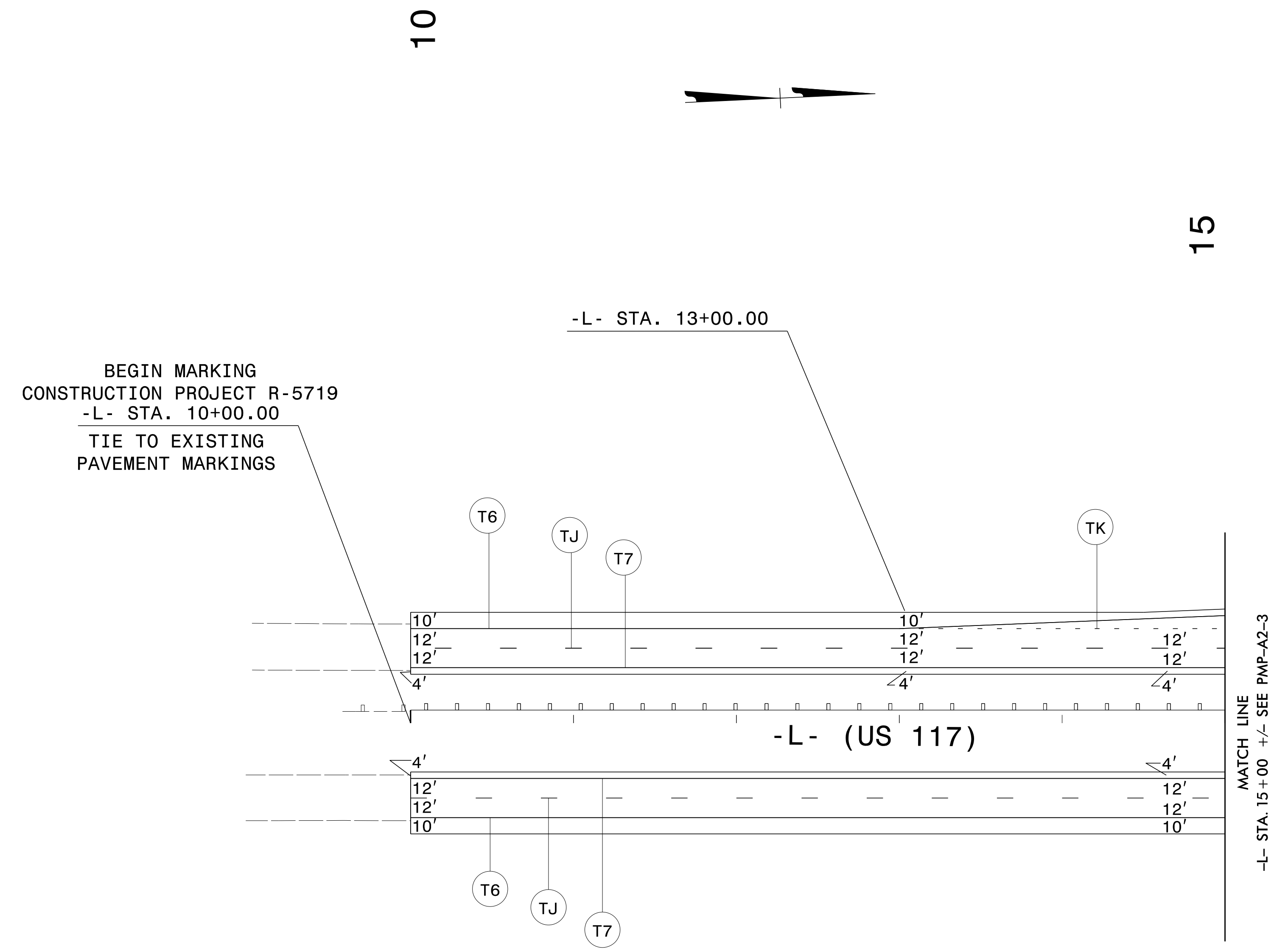

12/22/2016
P:\2015\NR-5719\TrafficControl\TCPVr5719_TC_PMP_PSH_A2-2.dgn
User:skennedy

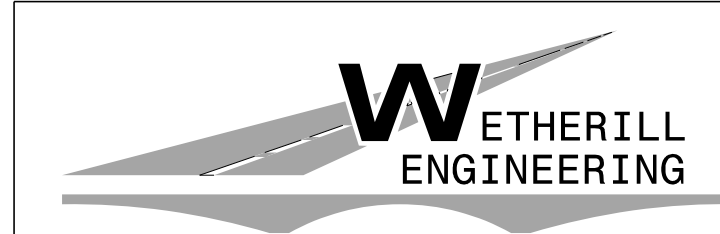

1223 Jones Franklin Rd.
Raleigh, N.C. 27606
License No. F-0377
Bus: 919 851 8077
Fax: 919 851 8107

TRANSPORTATION PLANNING/DESIGN - BRIDGE/STRUCTURE DESIGN
CIVIL/SITE DESIGN - GIS/GPS - CONSTRUCTION OBSERVATION

**DOCUMENT NOT CONSIDERED FINAL
UNLESS ALL SIGNATURES COMPLETED**

APPROVED: _____
DATE: _____

SEAL

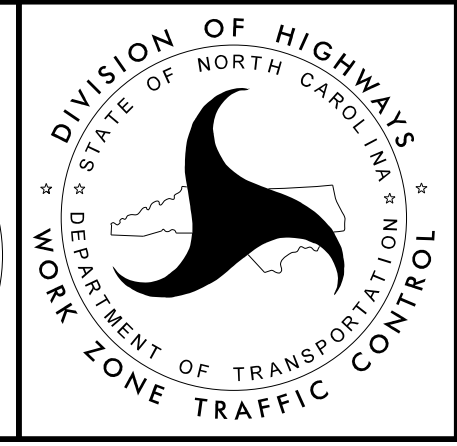

**AREA 2
FINAL PAVEMENT
MARKING PLANS**

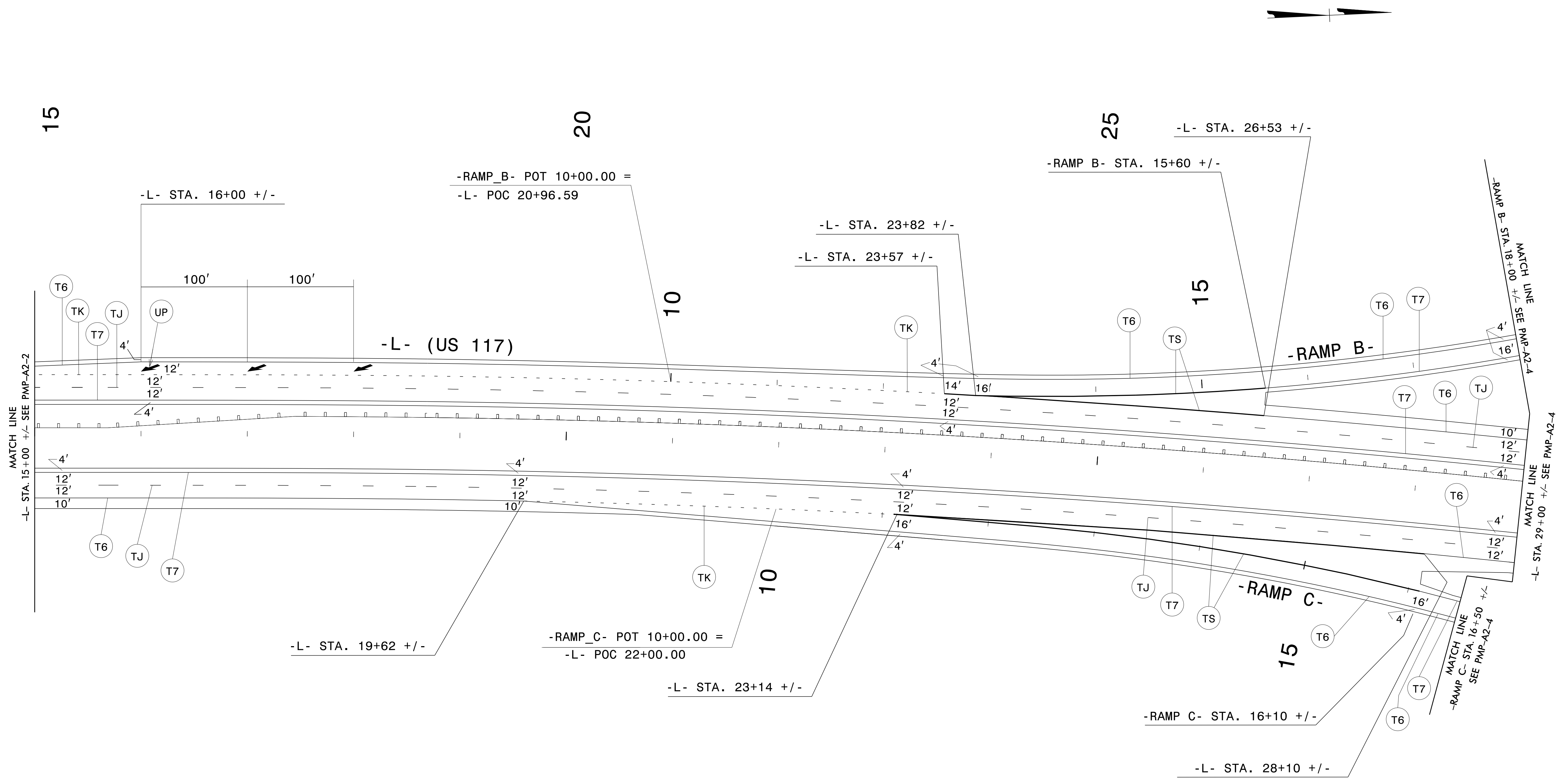

12/22/2016
P:\2015\5719-TrafficControl\TCPVr5719_TC_PMP_PSH_A2-3.dgn
User:skennedy

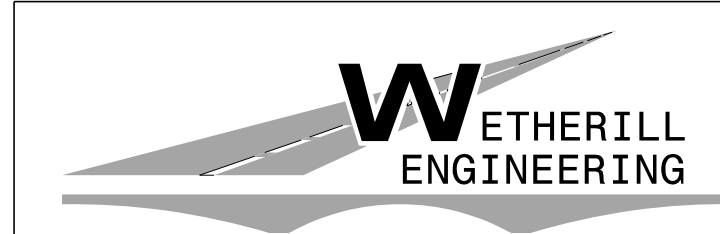

1223 Jones Franklin Rd.
Raleigh, N.C. 27606
License No. F-0377
Bus: 919 851 8077
Fax: 919 851 8107

TRANSPORTATION PLANNING/DESIGN - BRIDGE/STRUCTURE DESIGN
CIVIL/SITE DESIGN - GIS/GPS - CONSTRUCTION OBSERVATION

**DOCUMENT NOT CONSIDERED FINAL
UNLESS ALL SIGNATURES COMPLETED**

APPROVED: _____
DATE: _____

SEAL

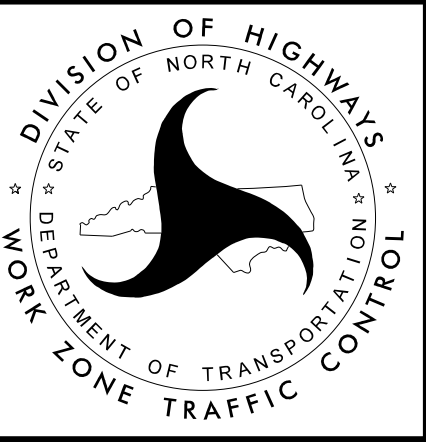

**AREA 2
FINAL PAVEMENT
MARKING PLANS**

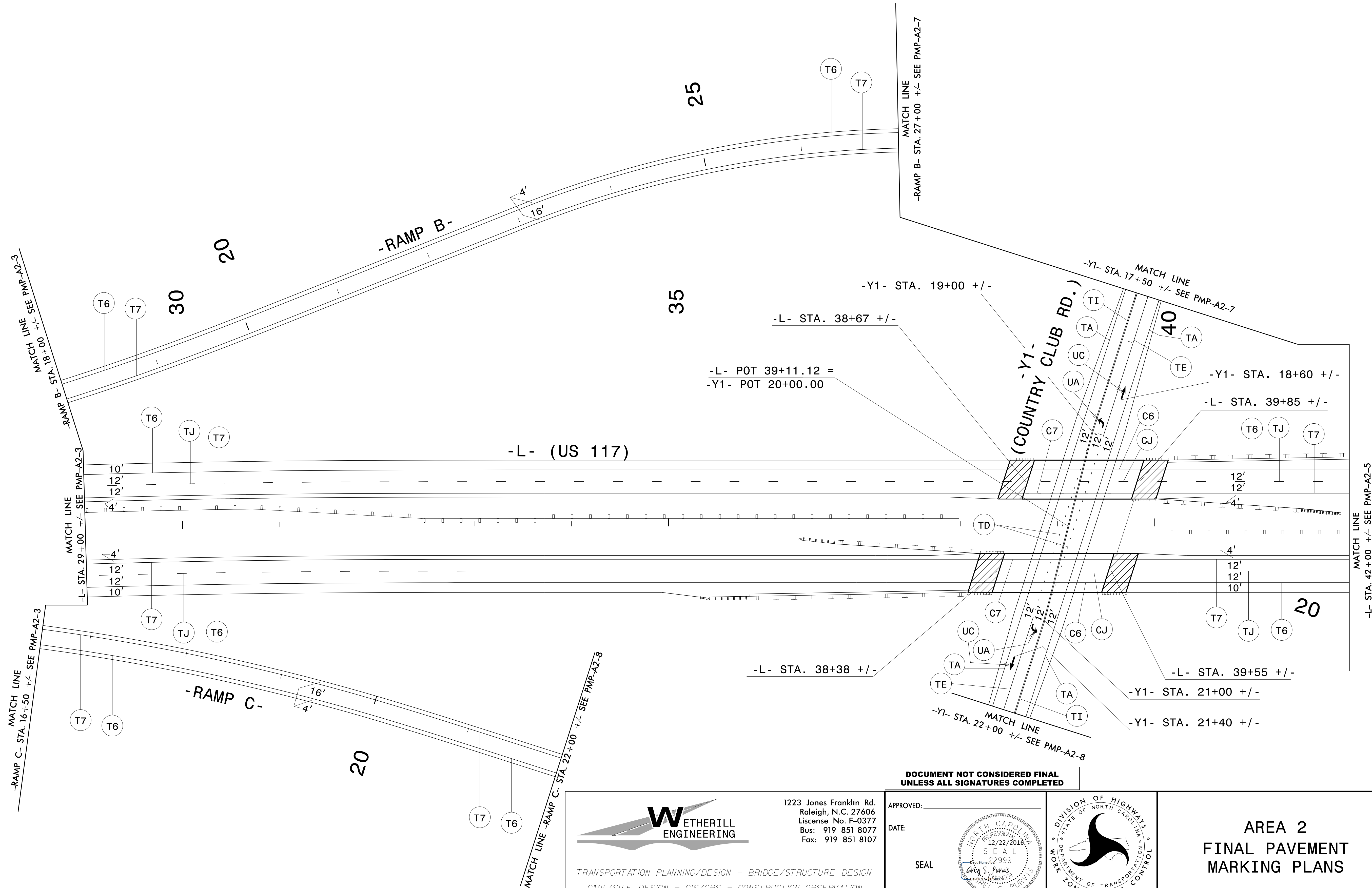
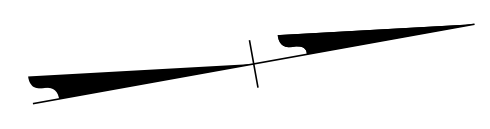

12/22/2016
 P:\2015\5719\TrafficControl\TCPVr5719_TC_PMP_PSH_A2-4.dgn
 User:skennedy

WETHERILL ENGINEERING

1223 Jones Franklin Rd.
 Raleigh, N.C. 27606
 License No. F-0377
 Bus: 919 851 8077
 Fax: 919 851 8107

TRANSPORTATION PLANNING/DESIGN - BRIDGE/STRUCTURE DESIGN
 CIVIL/SITE DESIGN - GIS/GPS - CONSTRUCTION OBSERVATION

**DOCUMENT NOT CONSIDERED FINAL
 UNLESS ALL SIGNATURES COMPLETED**

APPROVED: _____
 DATE: _____
 SEAL

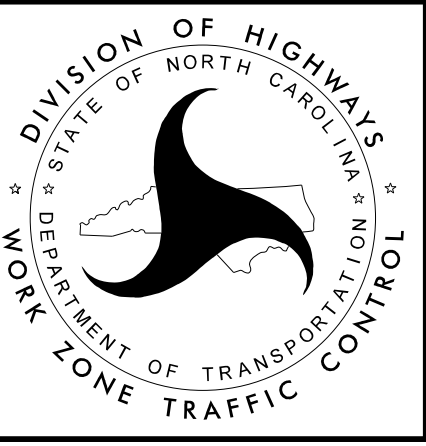

**AREA 2
 FINAL PAVEMENT
 MARKING PLANS**

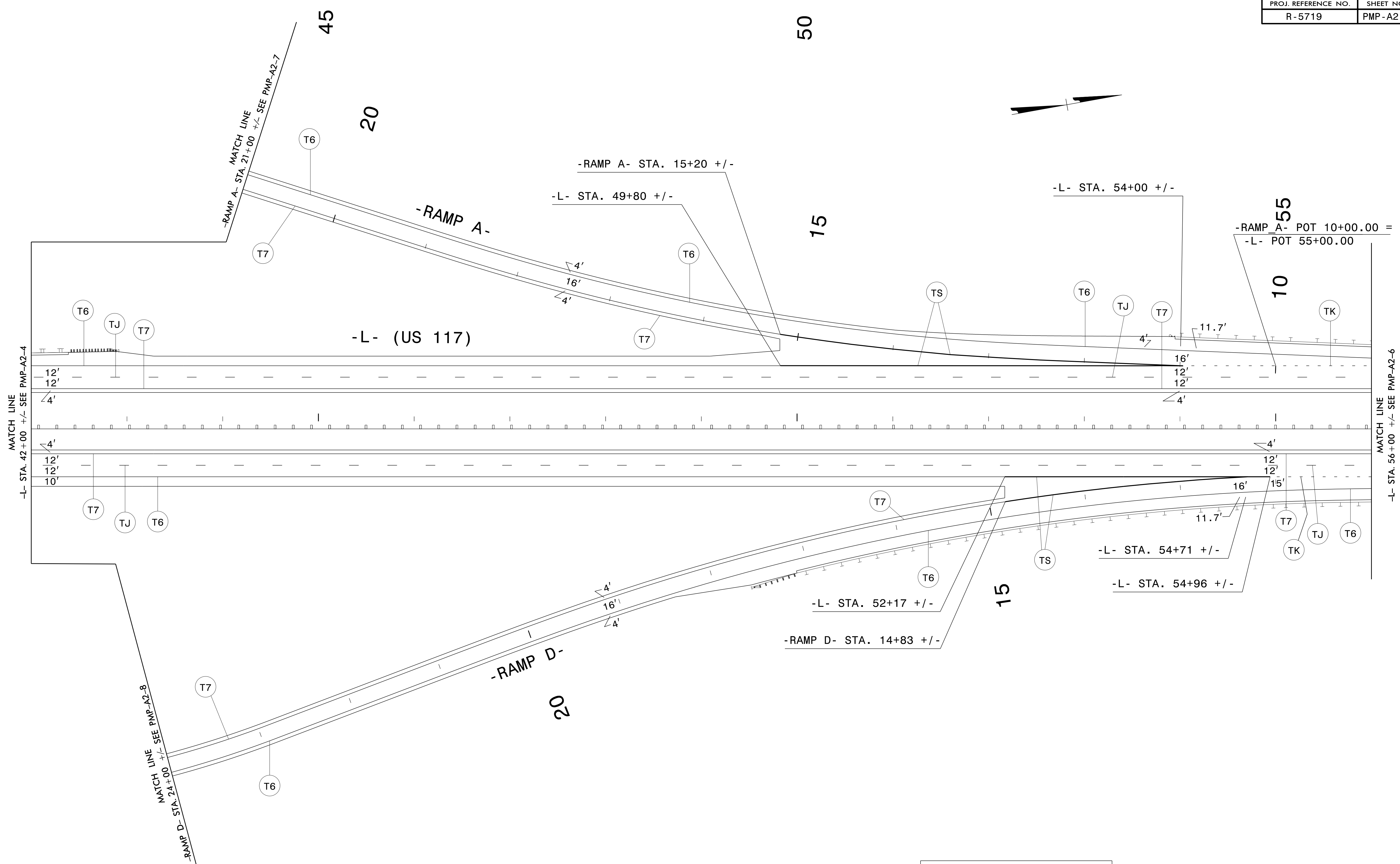

12/22/2016
 P:\2015\NR-5719\TrafficControl\TCPVr5719_TC_PMP_PSH_A2-5.dgn
 User:skennedy

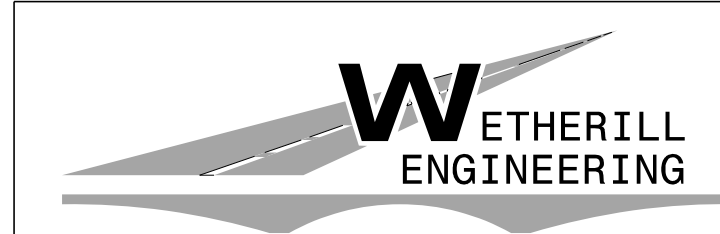

1223 Jones Franklin Rd.
 Raleigh, N.C. 27606
 License No. F-0377
 Bus: 919 851 8077
 Fax: 919 851 8107

TRANSPORTATION PLANNING/DESIGN - BRIDGE/STRUCTURE DESIGN
 CIVIL/SITE DESIGN - GIS/GPS - CONSTRUCTION OBSERVATION

**DOCUMENT NOT CONSIDERED FINAL
UNLESS ALL SIGNATURES COMPLETED**

APPROVED: _____
 DATE: _____
 SEAL

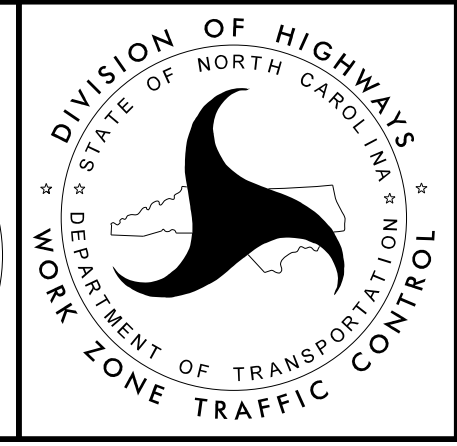
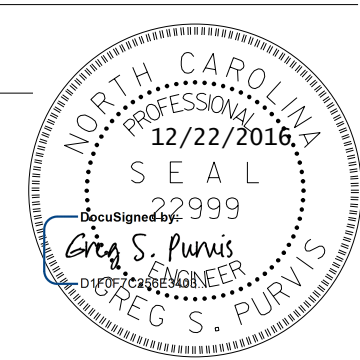

**AREA 2
FINAL PAVEMENT
MARKING PLANS**

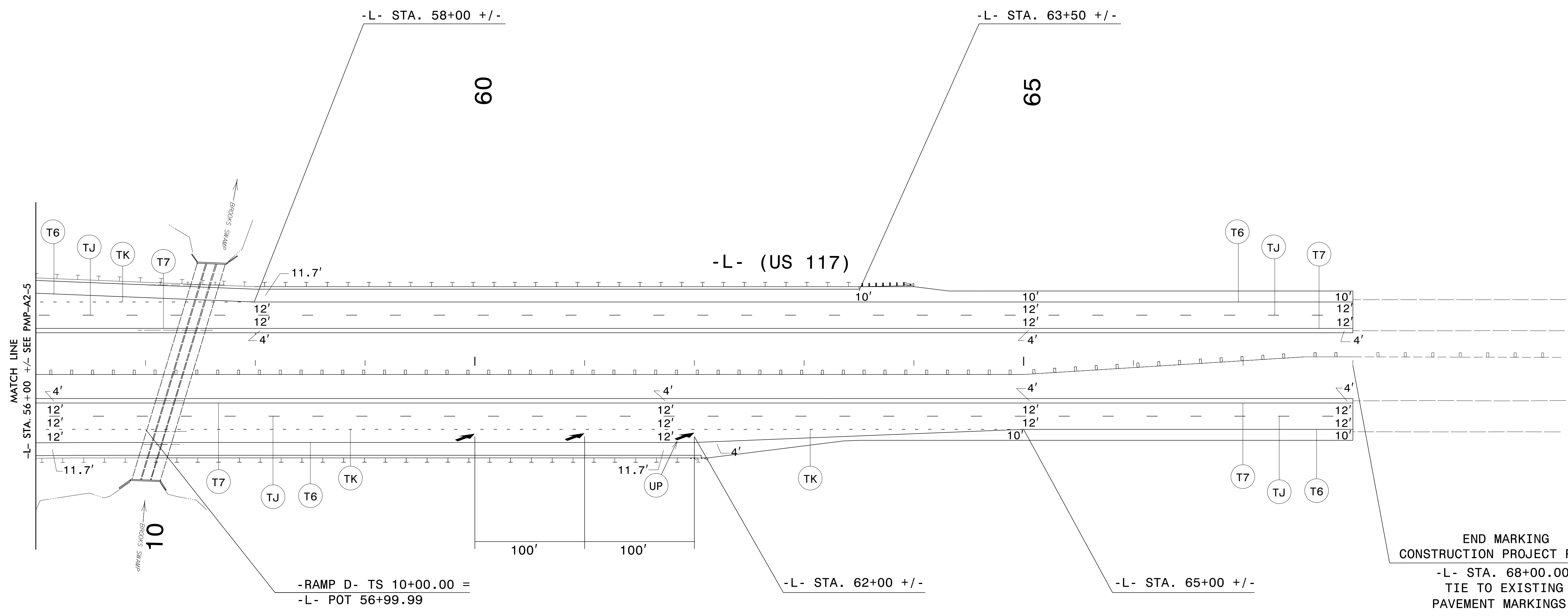
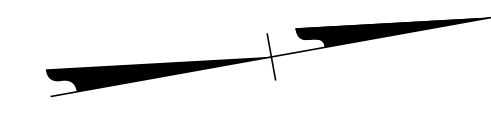

12/22/2016
 P:\2015\NR-5719\TrafficControl\TCVr5719_TC_PMP_PSH_A2-6.dgn
 User: skennedy

**DOCUMENT NOT CONSIDERED FINAL
 UNLESS ALL SIGNATURES COMPLETED**

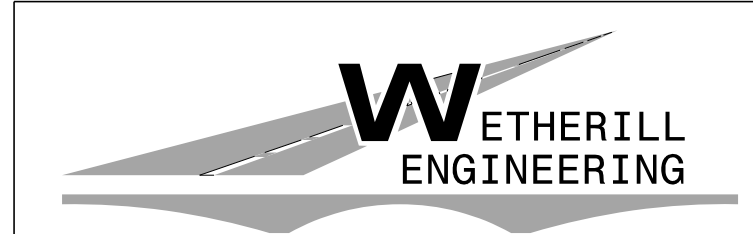

1223 Jones Franklin Rd.
 Raleigh, N.C. 27606
 License No. F-0377
 Bus: 919 851 8077
 Fax: 919 851 8107

TRANSPORTATION PLANNING/DESIGN - BRIDGE/STRUCTURE DESIGN
 CIVIL/SITE DESIGN - GIS/GPS - CONSTRUCTION OBSERVATION

APPROVED: _____
 DATE: _____

SEAL

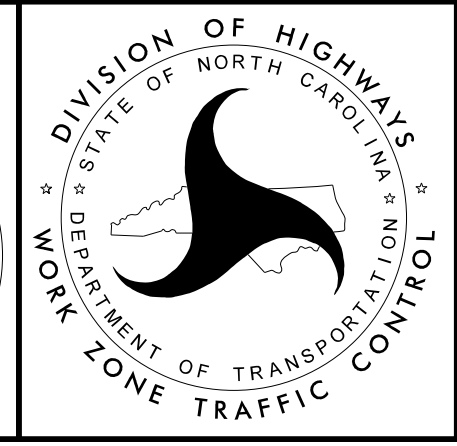

**AREA 2
 FINAL PAVEMENT
 MARKING PLANS**

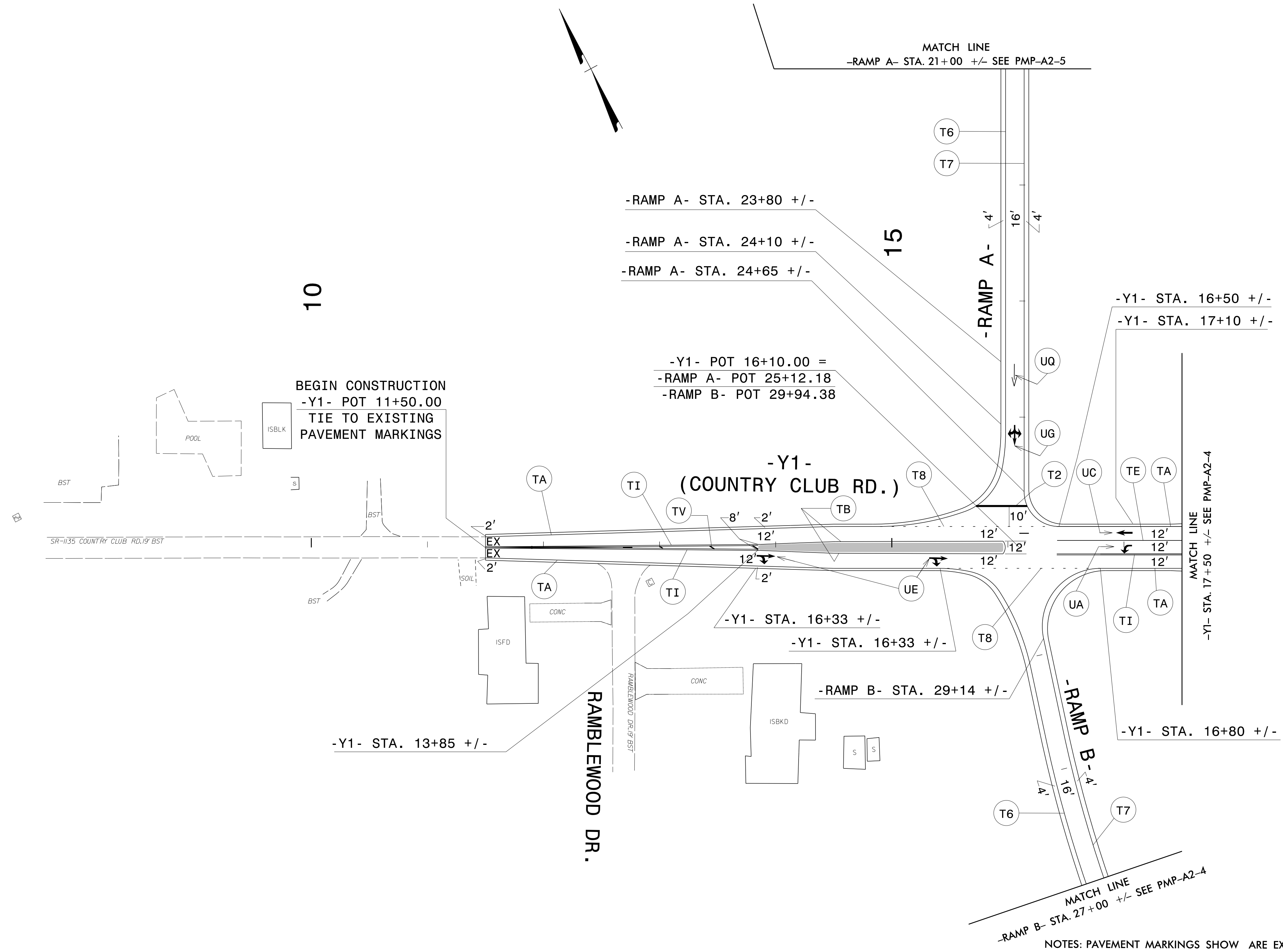

NOTES: PAVEMENT MARKINGS SHOW ARE EXISTING UNLESS OTHERWISE NOTED.
SEE TMP-1A FOR PAVEMENT MARKING SCHEDULE

**DOCUMENT NOT CONSIDERED FINAL
UNLESS ALL SIGNATURES COMPLETED**

WETHERILL ENGINEERING

1223 Jones Franklin Rd.
Raleigh, N.C. 27606
License No. F-0377
Bus: 919 851 8077
Fax: 919 851 8107

TRANSPORTATION PLANNING/DESIGN - BRIDGE/STRUCTURE DESIGN
CIVIL/SITE DESIGN - GIS/GPS - CONSTRUCTION OBSERVATION

APPROVED: _____
DATE: _____

SEAL

**AREA 2
FINAL PAVEMENT
MARKING PLANS**

12/22/2016
P:\2015\SR-5719\TrafficControl\TCPVr5719_TC_PMP_PSH_A2-7.dgn
User:skennedy

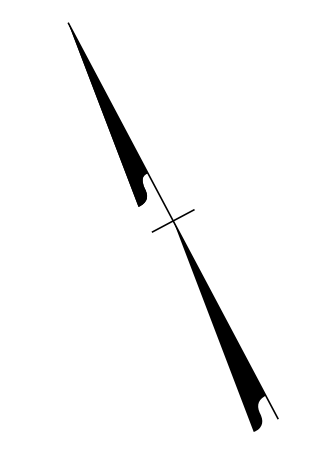
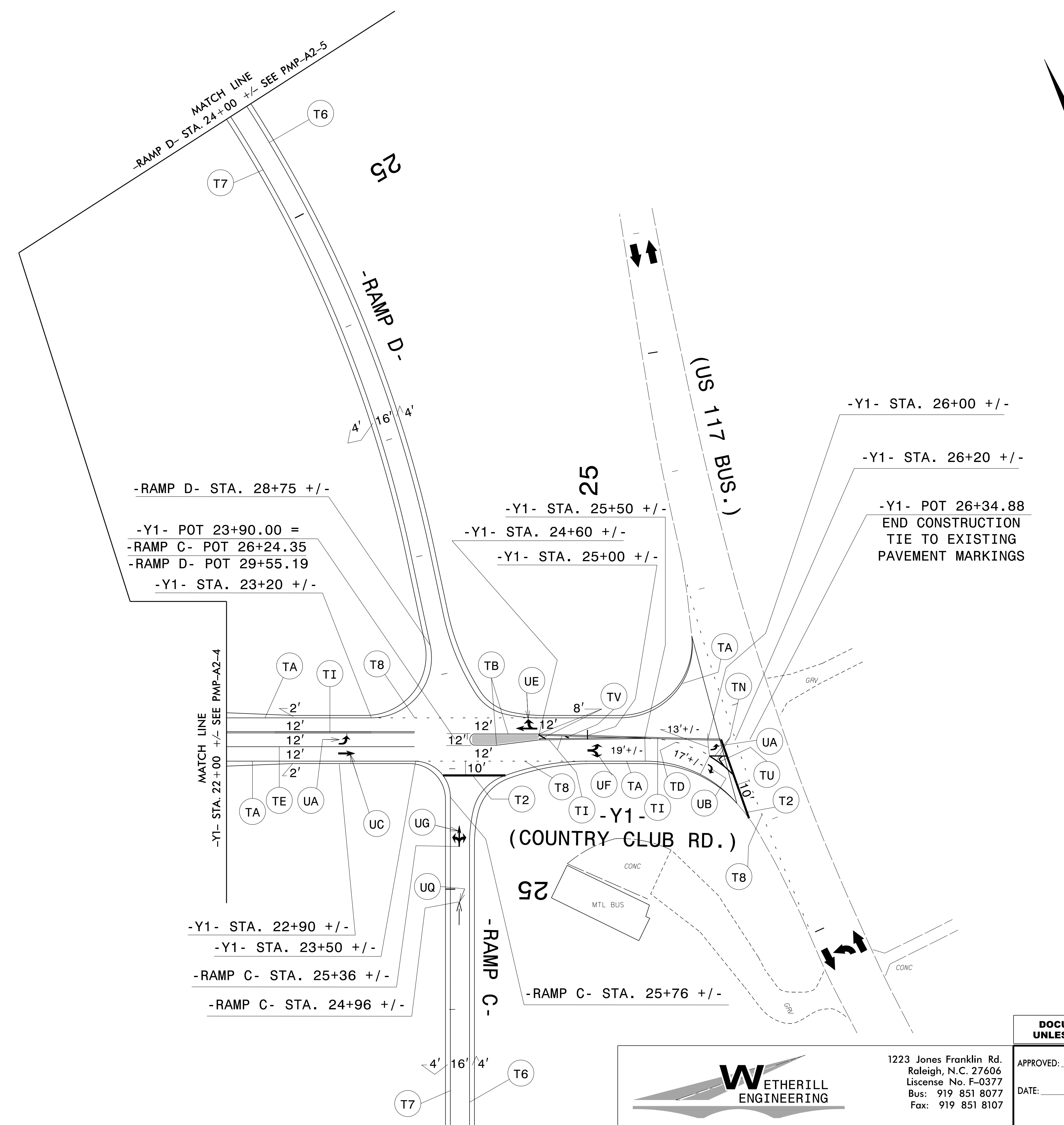

-RAMP D- STA. 28+75 +/-
 -Y1- POT 23+90.00 =
 -RAMP C- POT 26+24.35
 -RAMP D- POT 29+55.19
 -Y1- STA. 23+20 +/-

-Y1- STA. 25+50 +/-
 -Y1- STA. 24+60 +/-
 -Y1- STA. 25+00 +/-

-Y1- STA. 26+00 +/-
 -Y1- STA. 26+20 +/-
 -Y1- POT 26+34.88
 END CONSTRUCTION
 TIE TO EXISTING
 PAVEMENT MARKINGS

MATCH LINE
 -Y1- STA. 22+00 +/- SEE PMP-A2-4
 -Y1- STA. 22+90 +/-
 -Y1- STA. 23+50 +/-
 -RAMP C- STA. 25+36 +/-
 -RAMP C- STA. 24+96 +/-

-RAMP C- STA. 25+76 +/-
 -RAMP C- STA. 25+90 +/-

NOTES: PAVEMENT MARKINGS SHOW ARE EXISTING UNLESS OTHERWISE NOTED.
 SEE TMP-1A FOR PAVEMENT MARKING SCHEDULE

12/22/2016
 P:\2015\NR-5719\TrafficControl\TCPVr5719_TC_PMP_PSH_A2-8.dgn
 User:skennedy

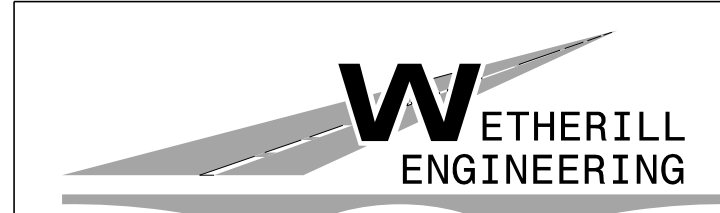

1223 Jones Franklin Rd.
 Raleigh, N.C. 27606
 License No. F-0377
 Bus: 919 851 8077
 Fax: 919 851 8107

TRANSPORTATION PLANNING/DESIGN - BRIDGE/STRUCTURE DESIGN
 CIVIL/SITE DESIGN - GIS/GPS - CONSTRUCTION OBSERVATION

**DOCUMENT NOT CONSIDERED FINAL
 UNLESS ALL SIGNATURES COMPLETED**

APPROVED: _____
 DATE: _____
 SEAL

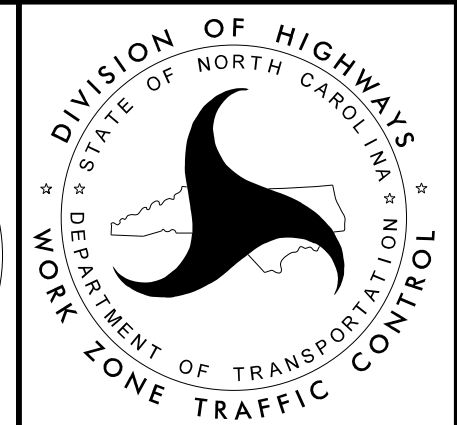
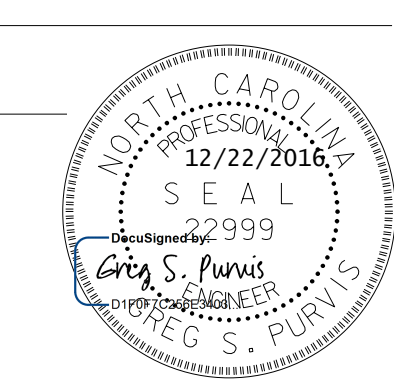

**AREA 2
 FINAL PAVEMENT
 MARKING PLANS**