

NOTES

THE CONCRETE IN THE SHADED AREA OF THE WING SHALL BE POURED AFTER THE PARAPET AND END POST ARE CAST IF SLIP FORMING IS USED.

INSTALL THE 4" DIA. DRAIN PIPE THROUGH THE WING WALL AS REQUIRED FOR REINFORCED BRIDGE APPROACH FILLS, SEE THE ROADWAY PLANS. REINFORCING STEEL IN THE WING WALL MAY BE SHIFTED AS NECESSARY TO CLEAR THE DRAIN PIPE.

THE TOP SURFACE OF THE END BENT CAP WITHIN THE LIMITS OF THE INTEGRAL ABUTMENT, EXCEPT THE BEARING AREA, SHALL BE RAKED TO A DEPTH OF 1/4".

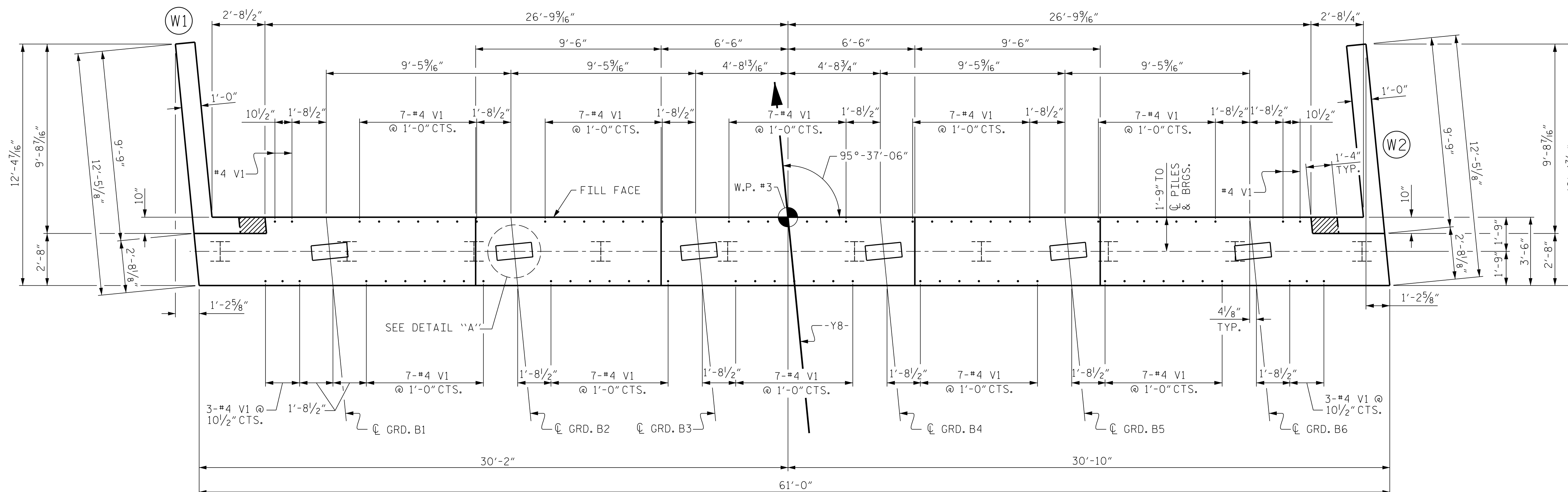

PLAN

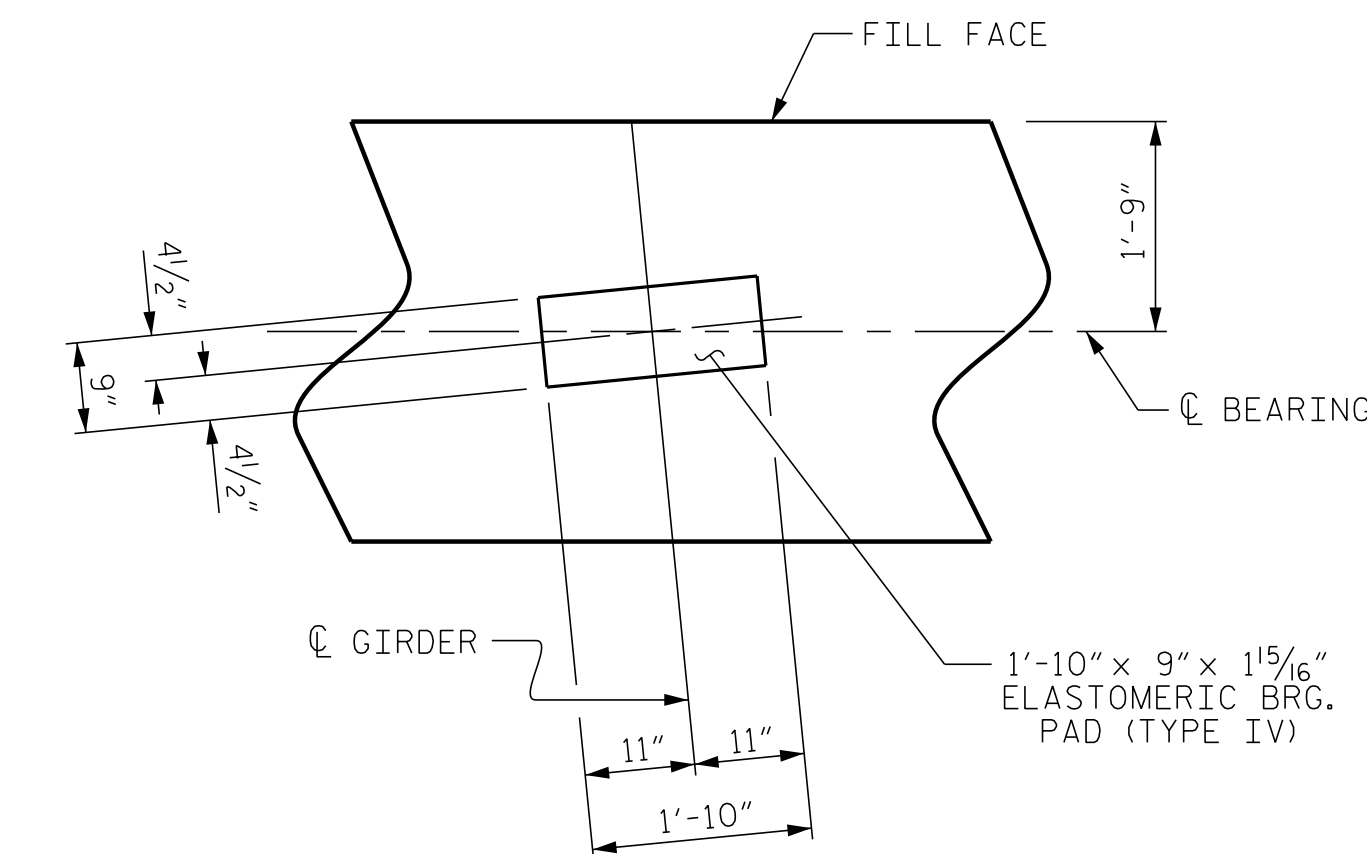

DETAIL A

(TYP. EACH GIRDER)

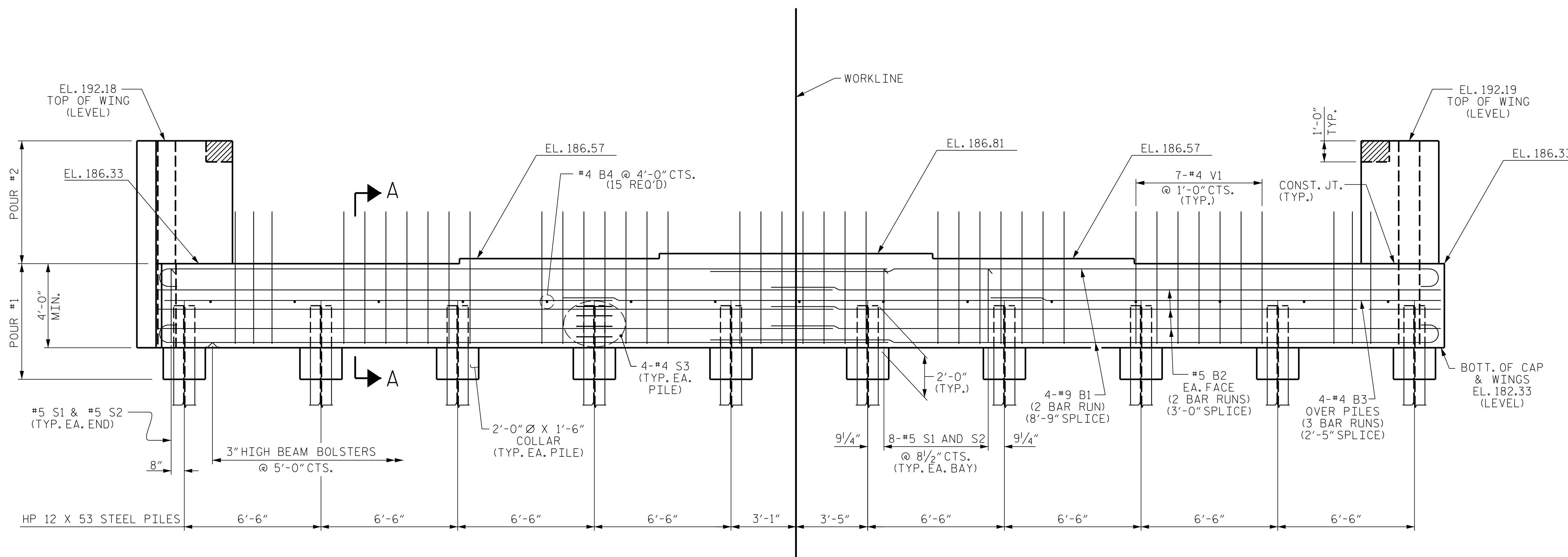

ELEVATION

FOR SECTION A-A, SEE SHEET 3 OF 3.

PROJECT NO. U-5796  
 WAYNE COUNTY  
 STATION: 27+41.30 -Y8-

SHEET 1 OF 3

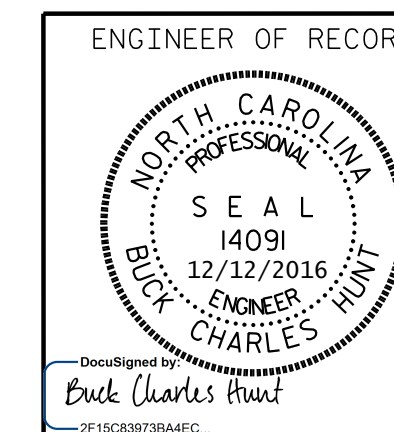

STATE OF NORTH CAROLINA  
 DEPARTMENT OF TRANSPORTATION  
 RALEIGH

SUBSTRUCTURE  
 END BENT No. 2

REVISIONS

NO.	BY:	DATE:	NO.	BY:	DATE:
1			3		
2			4		

SHEET NO.  
 S01-28  
 TOTAL SHEETS  
 34

DRAWN BY: B.C. HUNT/DAH DATE: 2/16  
 CHECKED BY: J. DILWORTH DATE: 2/16

DOCUMENT NOT CONSIDERED FINAL  
 UNLESS ALL SIGNATURES COMPLETED

P:\2015\U-5796\Structures\DG\U5796\_EB\_WE I.dgn  
 12/7/2016 11:32:05 AM