

NOTES

THE CONCRETE IN THE SHADED AREA OF THE WING SHALL BE POURED AFTER THE BARRIER RAILS ARE CAST IF SLIP FORMING IS USED.

INSTALL THE 4" DIA. DRAIN PIPE THROUGH THE WING WALL AS REQUIRED FOR REINFORCED BRIDGE APPROACH FILLS, SEE THE ROADWAY PLANS. REINFORCING STEEL IN THE WING WALL MAY BE SHIFTED AS NECESSARY TO CLEAR THE DRAIN PIPE.

THE TOP SURFACE OF THE END BENT CAP WITHIN THE LIMITS OF THE INTEGRAL ABUTMENT, EXCEPT THE BEARING AREA, SHALL BE RAKED TO A DEPTH OF 1/4".

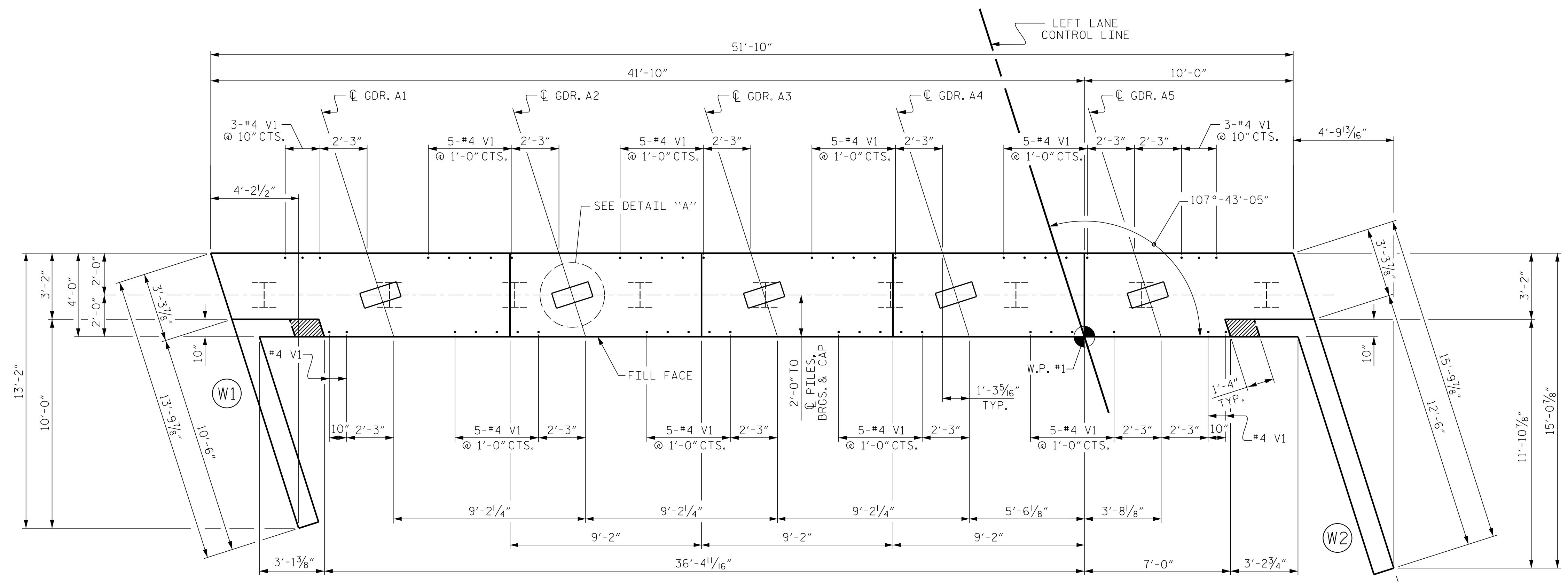

PLAN

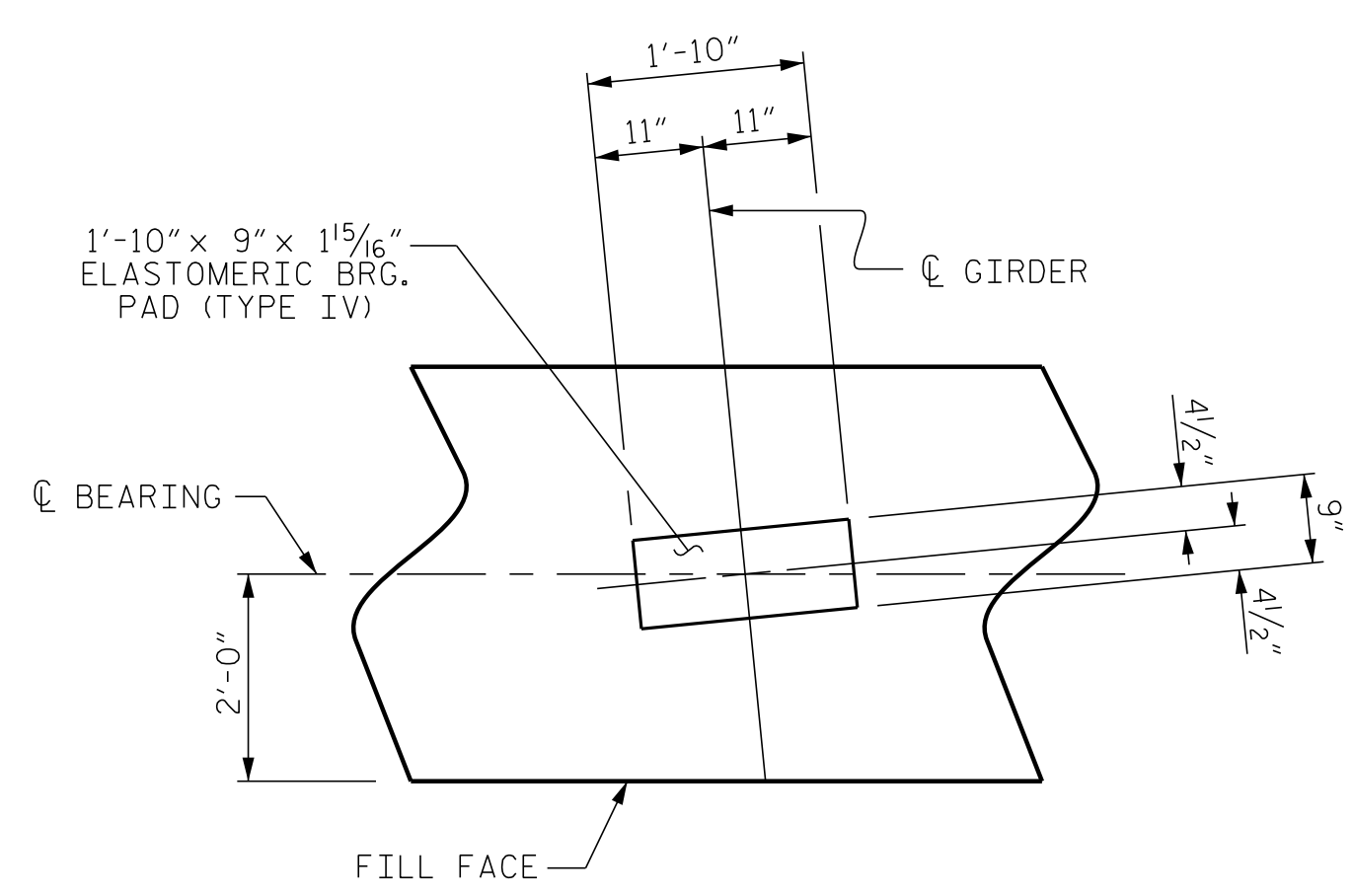

DETAIL A

(TYP. EACH GIRDER)

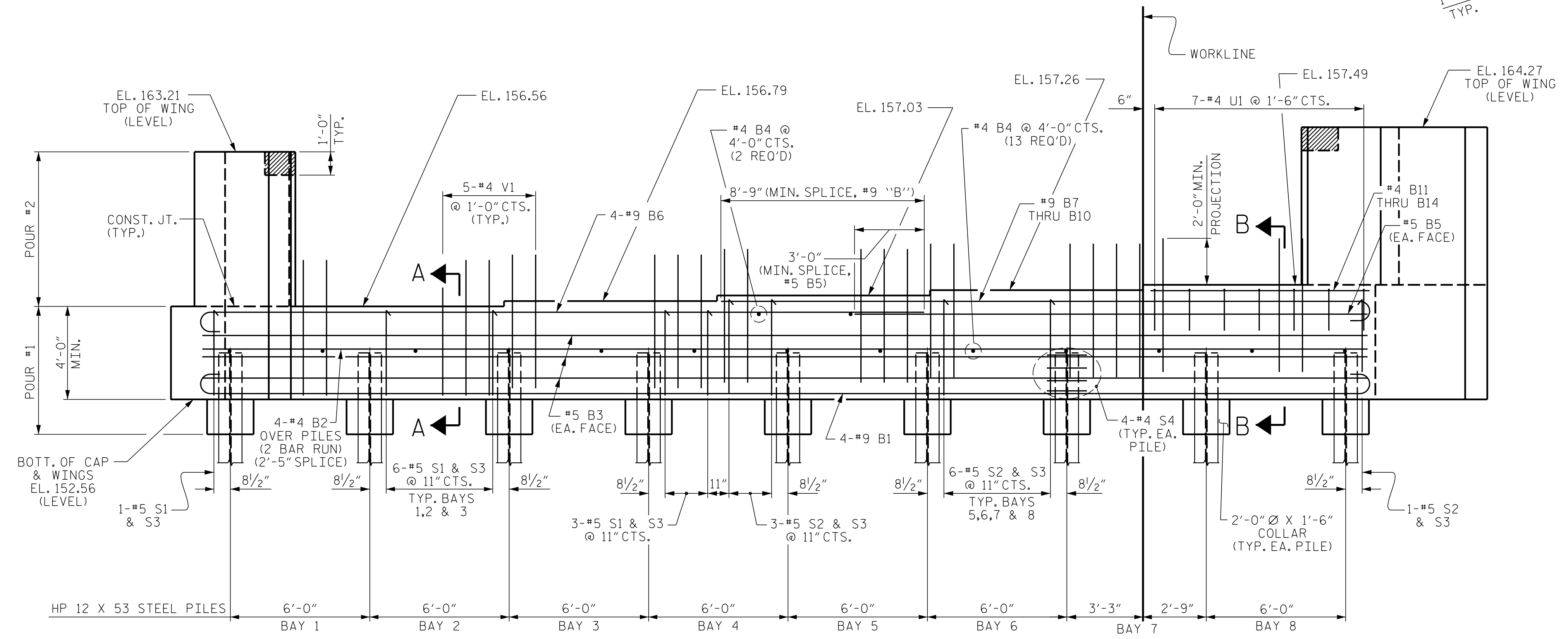

ELEVATION

FOR SECTIONS A-A & B-B, SEE SHEET 3 OF 3.

PROJECT NO. R-5719
 WAYNE COUNTY
 STATION: 39+11.12 -L-

SHEET 1 OF 3

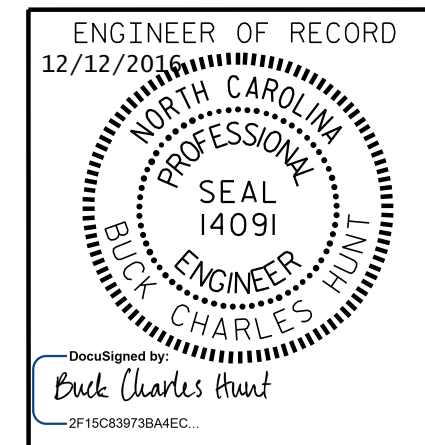

STATE OF NORTH CAROLINA
 DEPARTMENT OF TRANSPORTATION
 RALEIGH

**SUBSTRUCTURE
 END BENT No. 1
 (LEFT LANE)**

REVISIONS				SHEET NO.			
NO.	BY:	DATE:	NO.	BY:	DATE:	SHEET NO.	
1			3			S01-17	
2			4			TOTAL SHEETS 26	

DRAWN BY: D. HODGE DATE: 2/16
 CHECKED BY: J. DILWORTH DATE: 2/16

DOCUMENT NOT CONSIDERED FINAL
 UNLESS ALL SIGNATURES COMPLETED

P:\2015\A-5719\Structures\DWG\Left Lane\A-5719_L1_EBT_WE_I.dgn
 12/16/2016 1:04:33 PM