

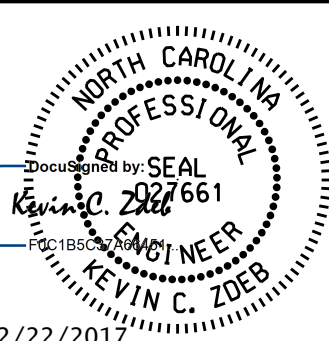
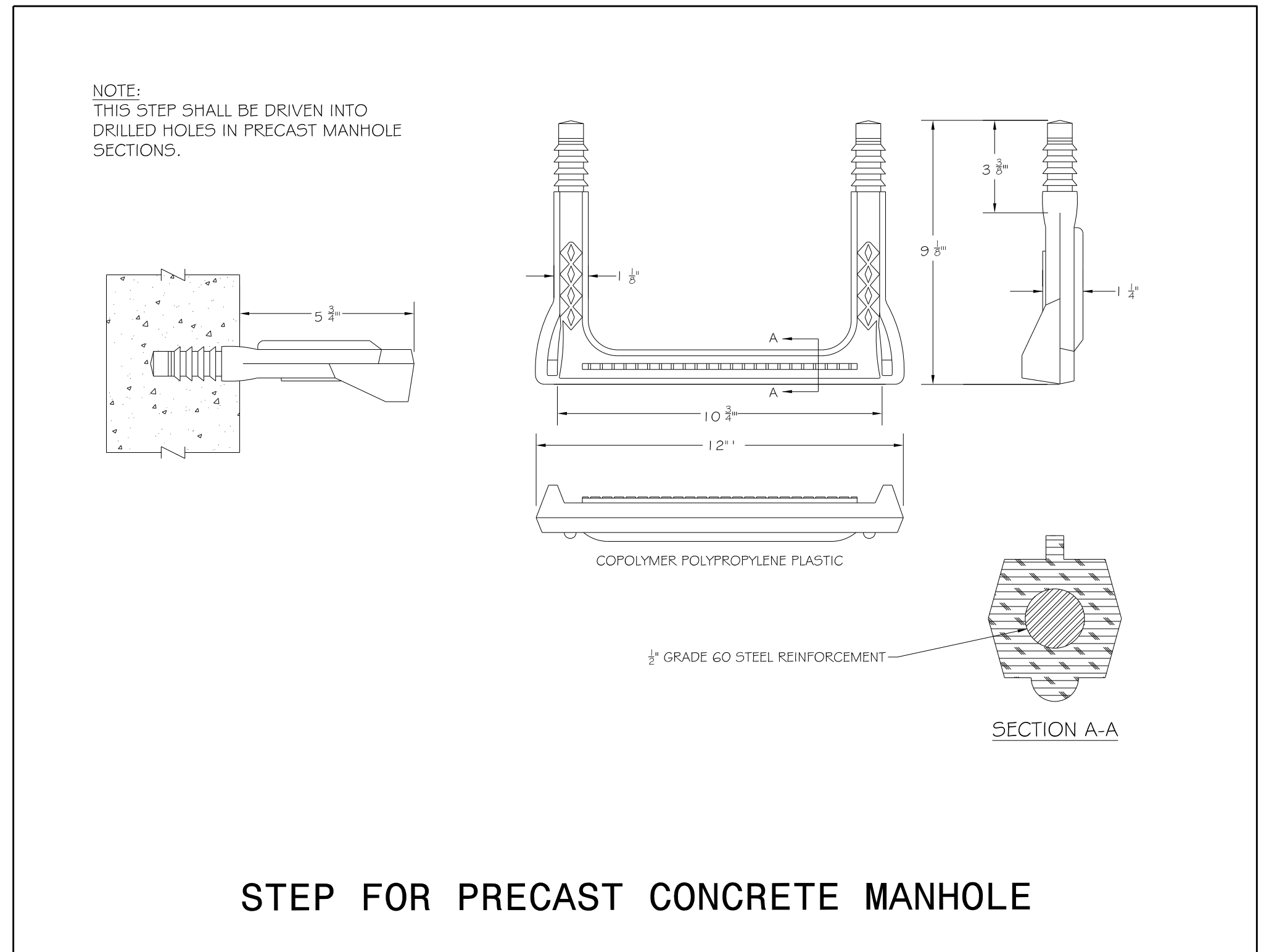

PROJECT REFERENCE NO. U-3621A	SHEET NO. UC-3I
DESIGNED BY: GJB	
DRAWN BY: GJB	
CHECKED BY: KCZ	
APPROVED BY: KCZ	
REVISED:	
NORTH CAROLINA DEPARTMENT OF TRANSPORTATION UTILITIES ENGINEERING SEC. PHONE: (919) 707-6690 FAX: (919) 250-4151	
UTILITY CONSTRUCTION PLANS ONLY 2/22/2017 KEVIN C. ZOLNER	
UTILITY CONSTRUCTION	
DOCUMENT NOT CONSIDERED FINAL UNTIL ALL SIGNATURES ARE COMPLETED	
 M A Engineering Consultants, Inc. <small>998 East Chatham Street - Suite 137 Cary, NC 27511 Phone: 919.297.0220 Fax: 919.297.0221 NC License: F-0160</small>	

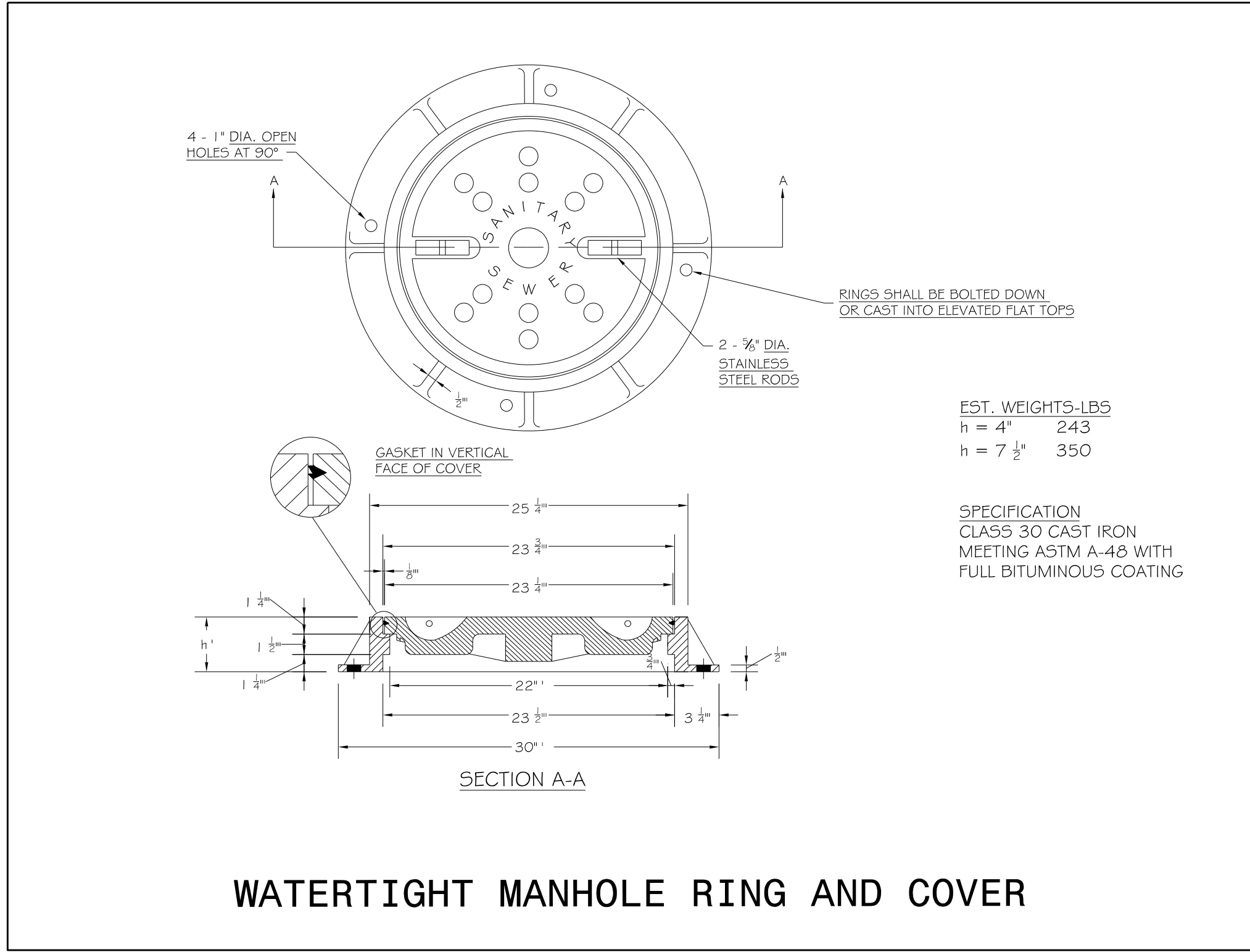
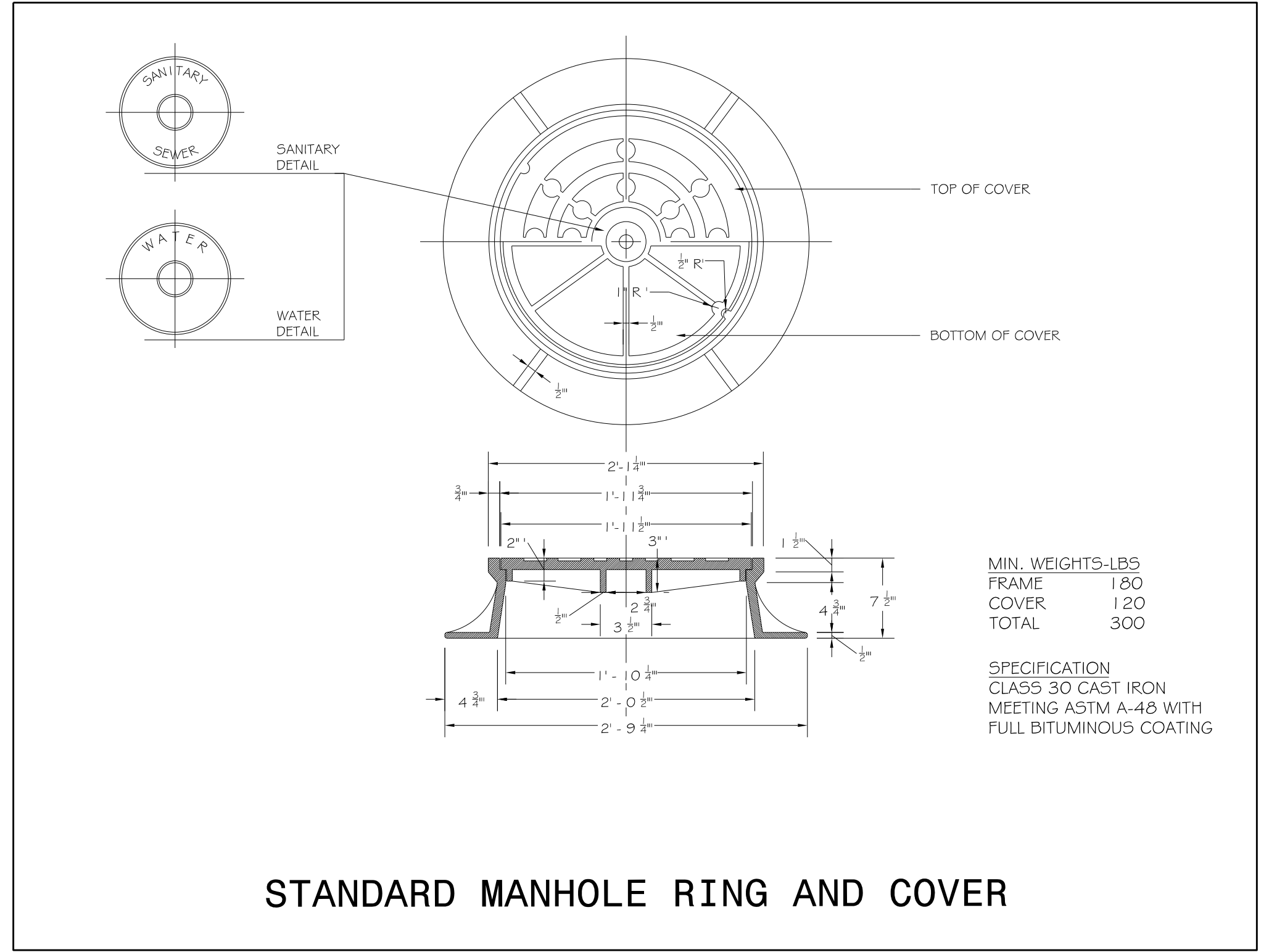

5/14/99
 65
 66
 67
 68
 69
 70
 71
 72
 73
 74
 75
 76
 77
 78
 79
 80
 81
 82
 83
 84
 85
 86
 87
 88
 89
 90
 91
 92
 93
 94
 95
 96
 97
 98
 99
 100