

NOTES:

STIRRUPS IN CAP MAY BE SHIFTED AS NECESSARY TO CLEAR ANCHOR BOLTS.

HOOKS ON V1 BARS MAY BE TURNED AS NECESSARY FOR PLACING REINFORCING STEEL.

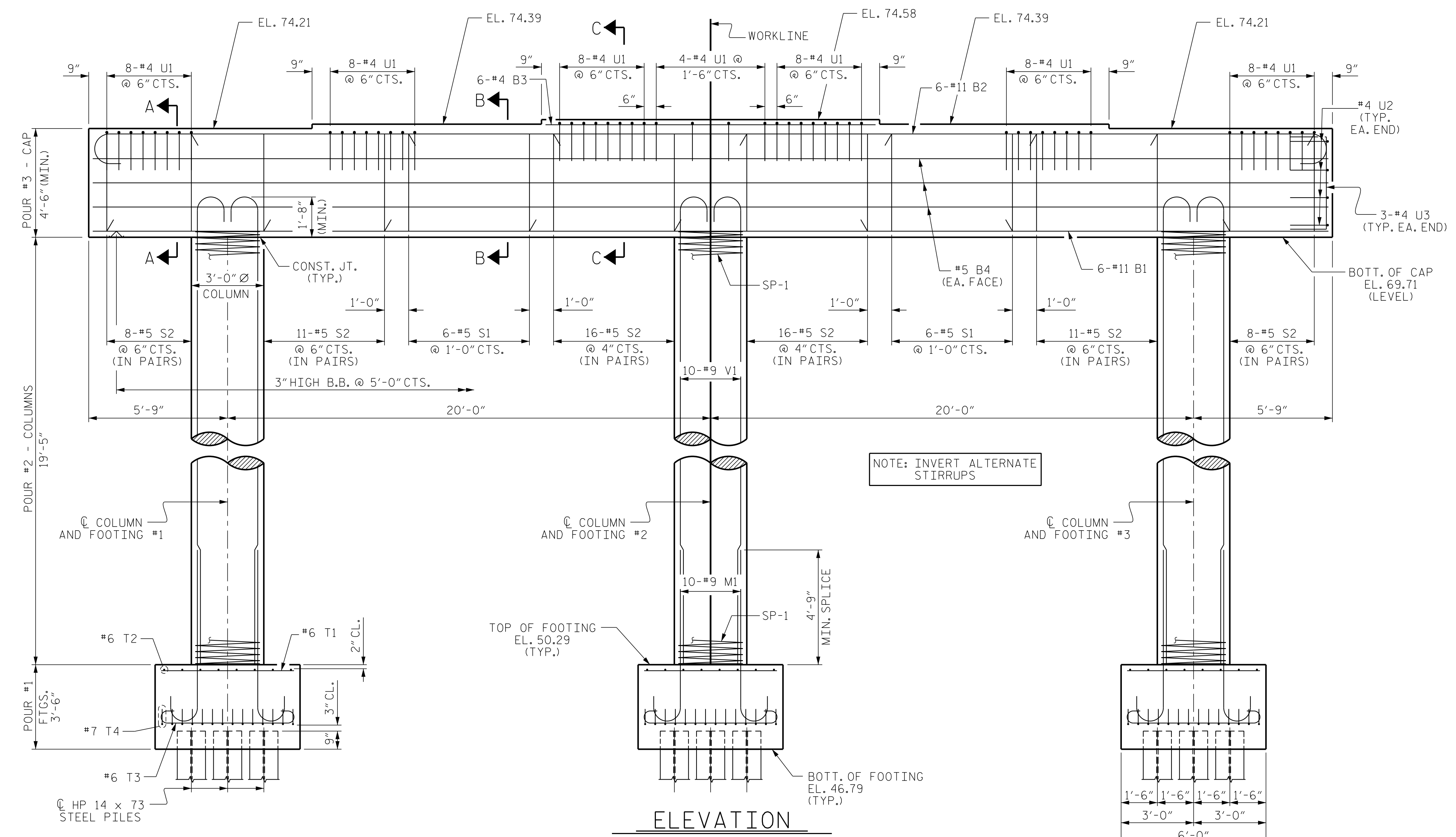
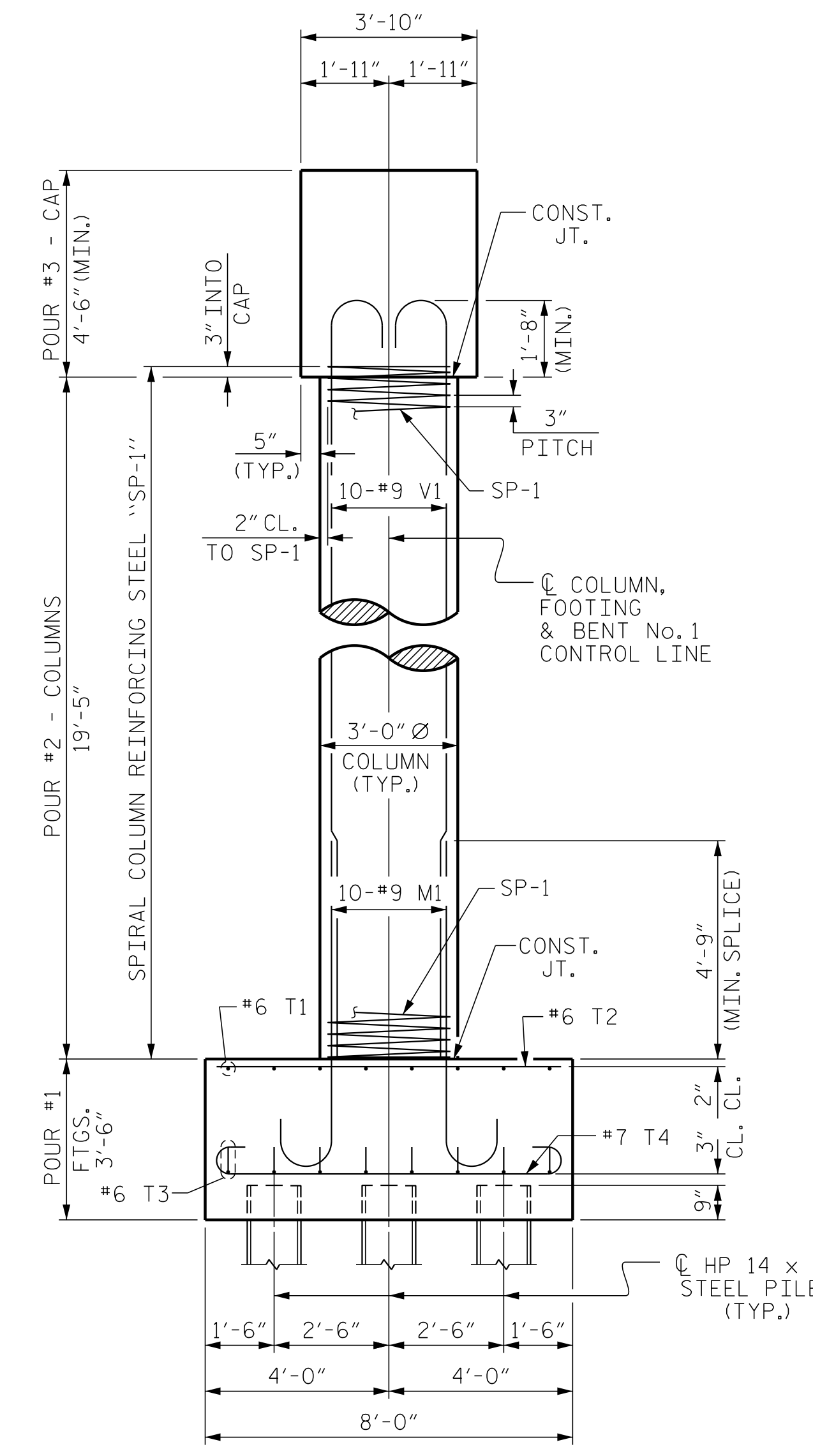

NOTE: INVERT ALTERNATE STIRRUPS

PILE PLACEMENT, REINFORCING STEEL AND DIMENSIONS ARE TYPICAL FOR EACH FOOTING AND COLUMN.

DOCUMENT NOT CONSIDERED FINAL UNLESS ALL SIGNATURES COMPLETED

P:\2015\A-5311A\Structures\Str 2 -Y2-DMNR-5311A-STR-Y2-BT.dgn 12/20/2016 2:50:31 PM

DRAWN BY: D. HODGE DATE: 7/16
CHECKED BY: J. DILWORTH DATE: 8/16

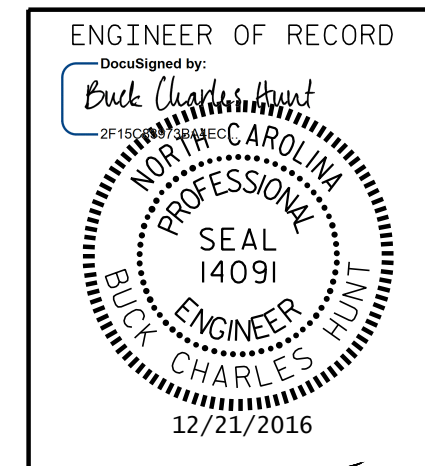

1223 Jones Franklin Rd.
Raleigh, N.C. 27606
Bus: 919 851 8077
Fax: 919 851 8107
LICENSE NO. F-0377

PROJECT NO. R-5311A
HERTFORD COUNTY
STATION: 50+99.00 -Y2-
SHEET 1 OF 2

STATE OF NORTH CAROLINA DEPARTMENT OF TRANSPORTATION RALEIGH					
SUBSTRUCTURE BENT No. 1					
REVISIONS					
NO.	BY:	DATE:	NO.	BY:	DATE:
1			3		
2			4		

SHEET NO. S02-23
TOTAL SHEETS 61