

PROJECT REFERENCE NO. B-5345	SHEET NO. EC-5/CONST. 5
ROADWAY ENGINEER	HYDRAULICS ENGINEER

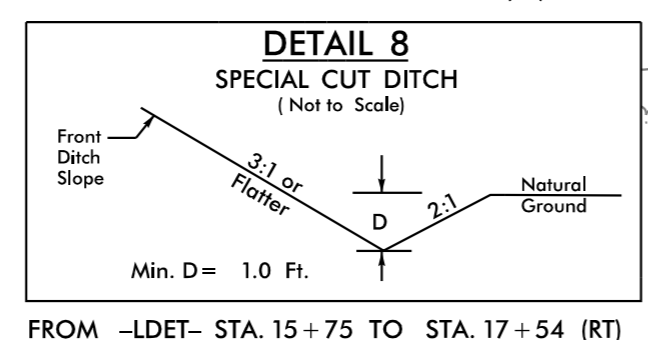
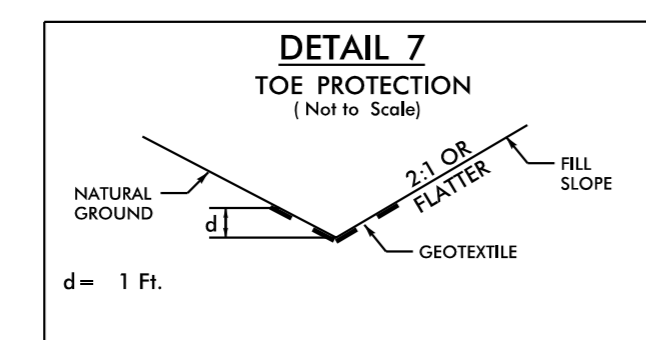
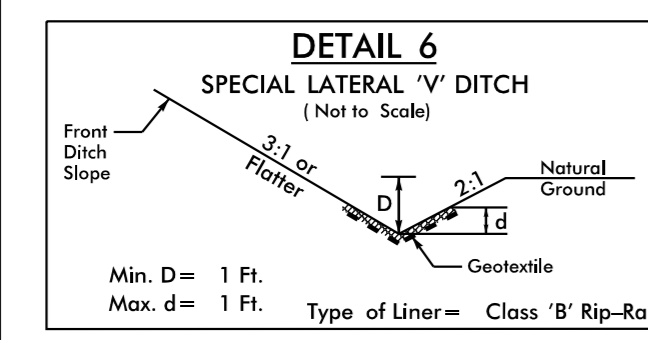
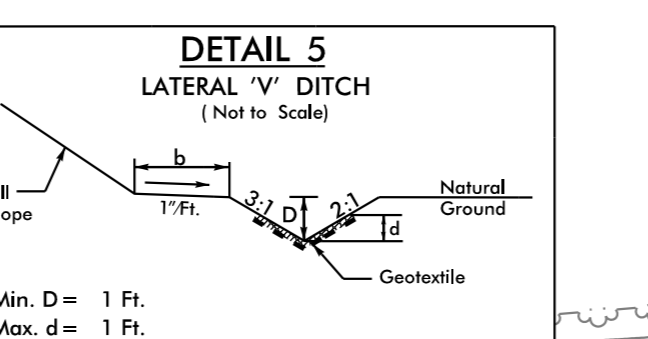
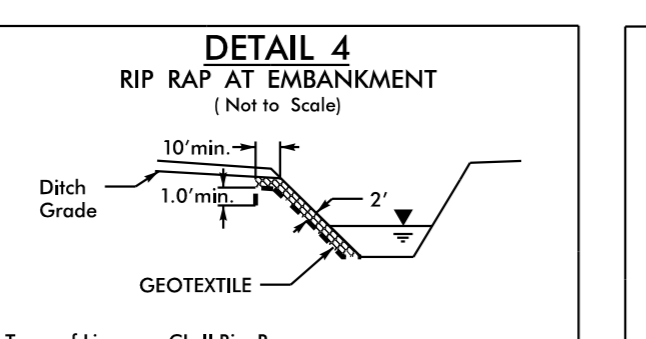
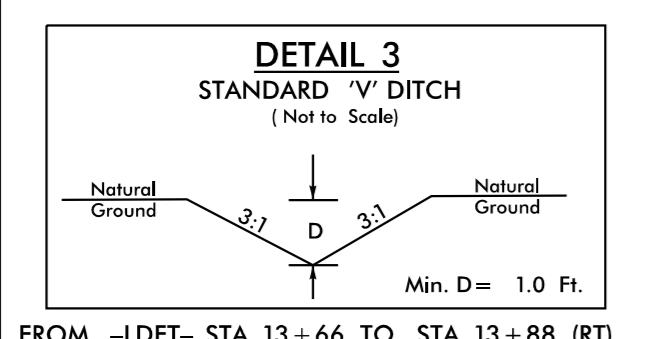
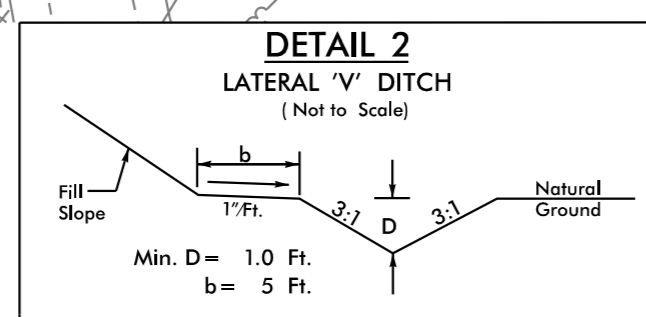
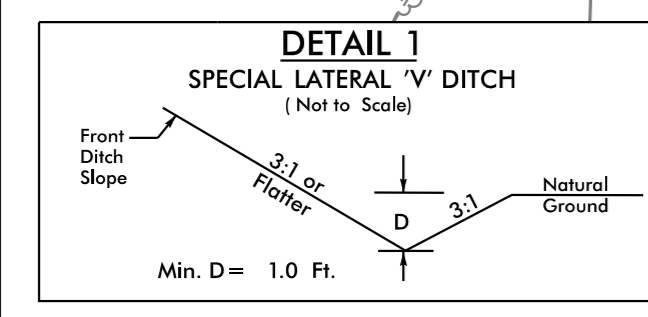
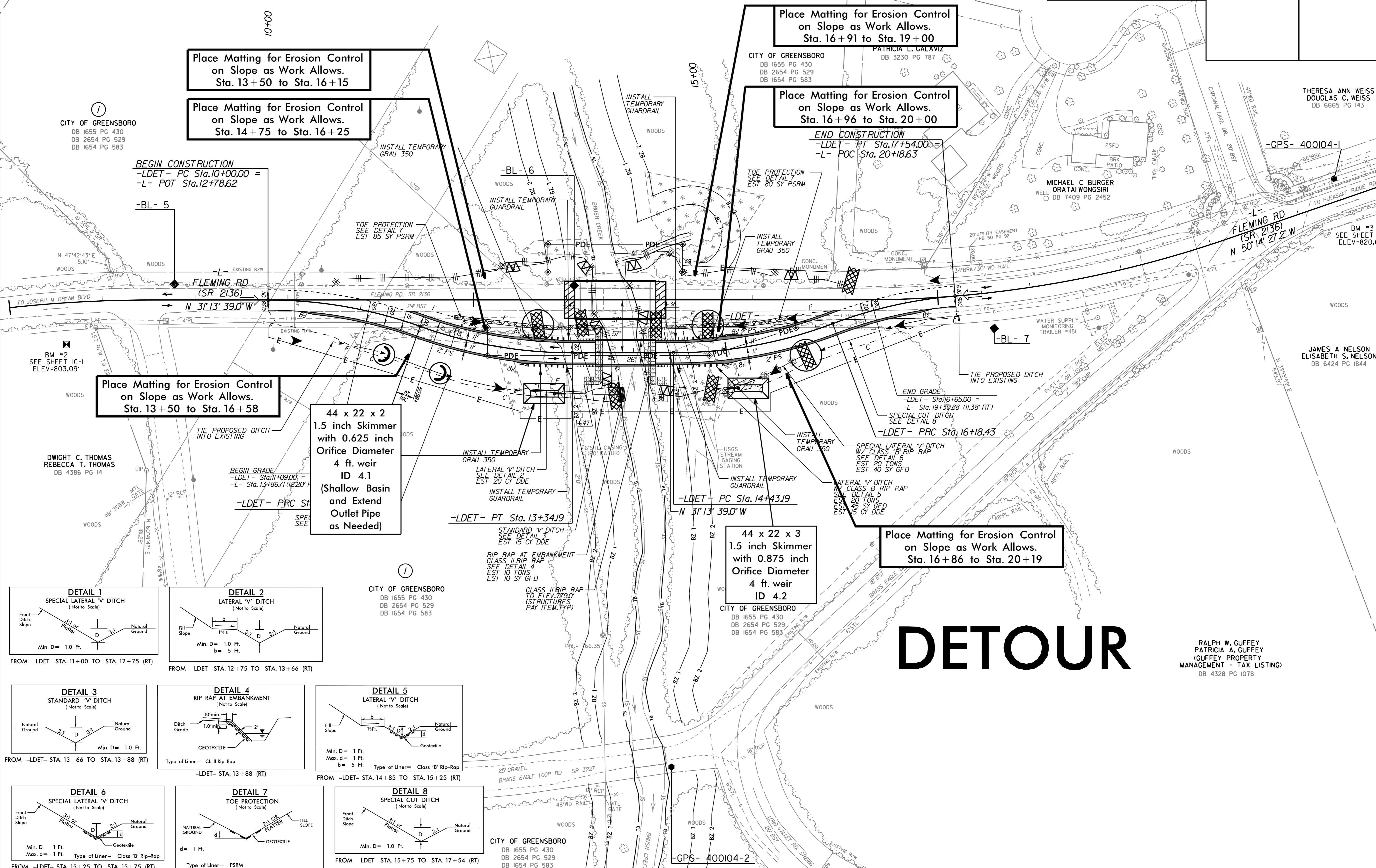
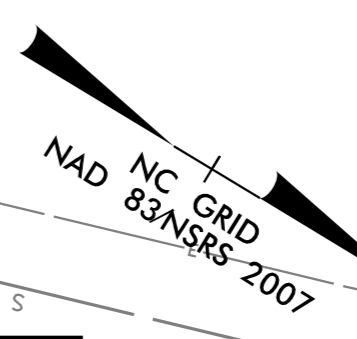

**DETOUR**

RALPH W. GUFFEY  
PATRICIA A. GUFFEY  
(GUFFEY PROPERTY  
MANAGEMENT - TAX LISTING)  
DB 4328 PG 1078

K:\PAL\_Roadway\01036275 - B-5345-Erosion Contron\B5345\_ero\_pst05.dgn 2/16/2017

SEE SHEET 6 FOR -LDET- PROFILE