

**This electronic collection of documents is provided
for the convenience of the user
and is Not a Certified Document –**

**The documents contained herein were originally issued
and sealed by the individuals whose names and license
numbers appear on each page, on the dates appearing
with their signature on that page.**

**This file or an individual page
shall not be considered a certified document.**

TIP PROJECT: B-5165

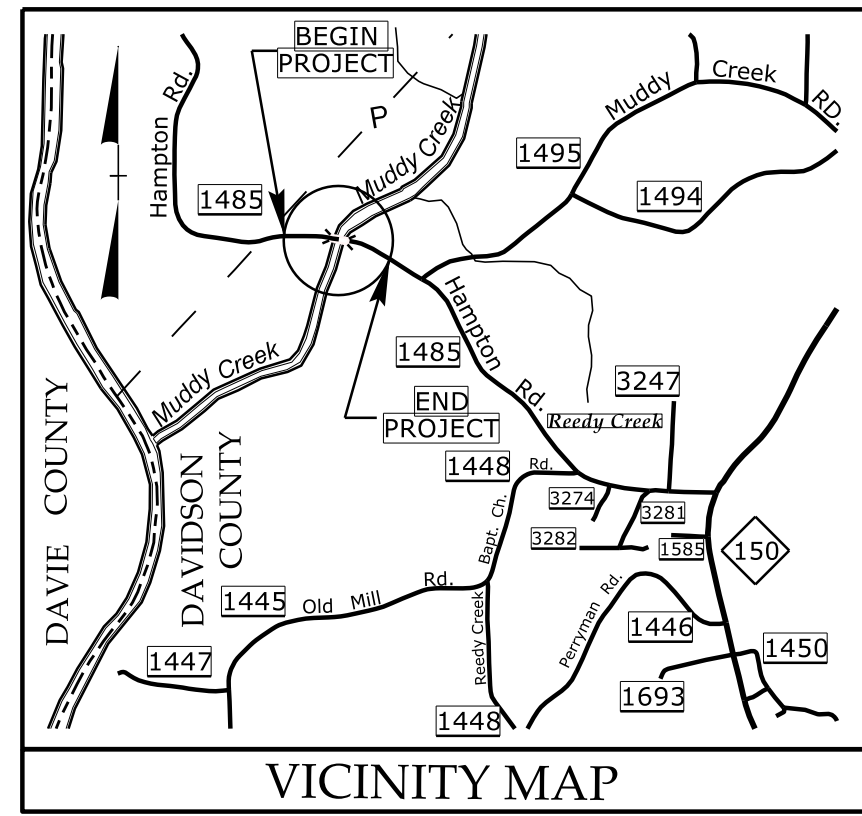

STATE OF NORTH CAROLINA
DIVISION OF HIGHWAYS

**UTILITIES BY OTHERS PLANS
DAVIDSON COUNTY**

LOCATION: BRIDGE NO. 42 OVER MUDDY CREEK ON SR 1485 (HAMPTON RD.)

**TYPE OF WORK: POWER DISTRIBUTION, TELEPHONE
AND CABLE TELEVISION RELOCATION**

T.I.P. NO.	SHEET NO.
B-5165	UO-1

NOTE:
ALL UTILITY WORK SHOWN ON THIS SHEET IS DONE BY OTHERS.
NO PAYMENT WILL BE MADE TO THE CONTRACTOR FOR UTILITY WORK SHOWN ON THIS SHEET.

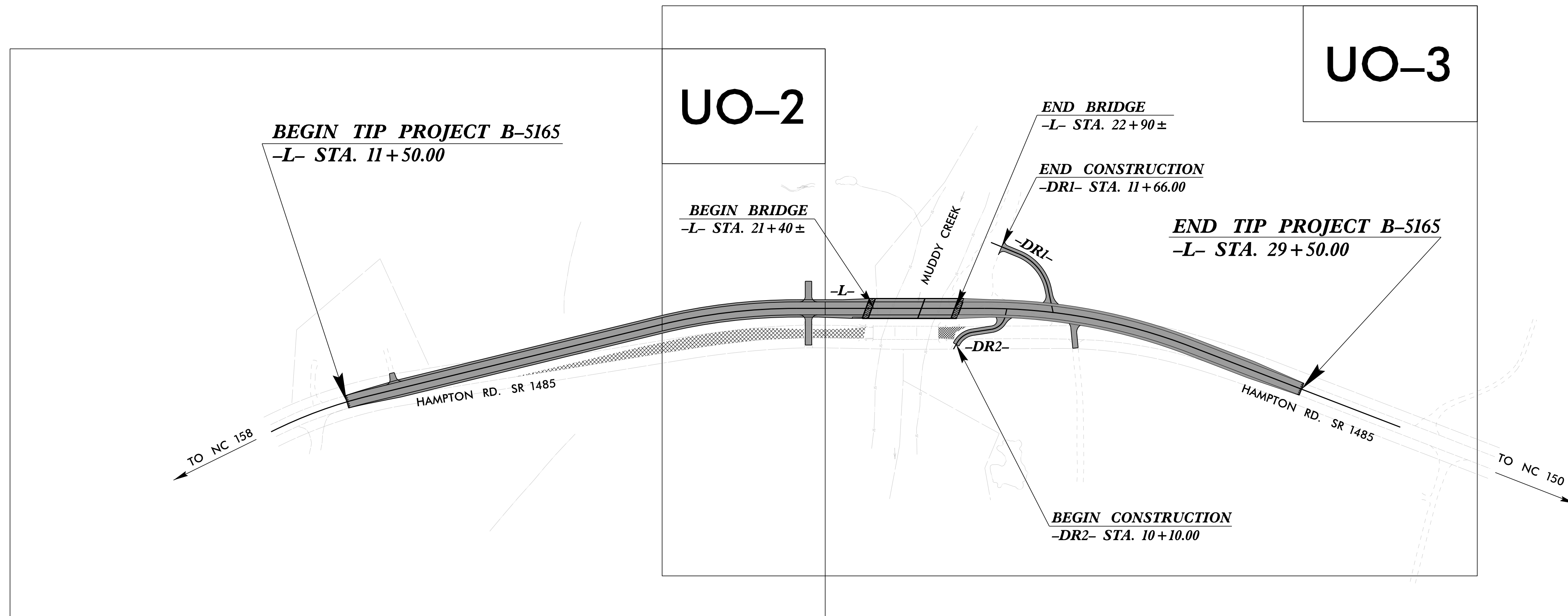

CLEARING ON THIS PROJECT SHALL BE PERFORMED TO THE LIMITS ESTABLISHED BY METHOD ____.
THIS PROJECT IS NOT WITHIN ANY MUNICIPAL BOUNDARIES.

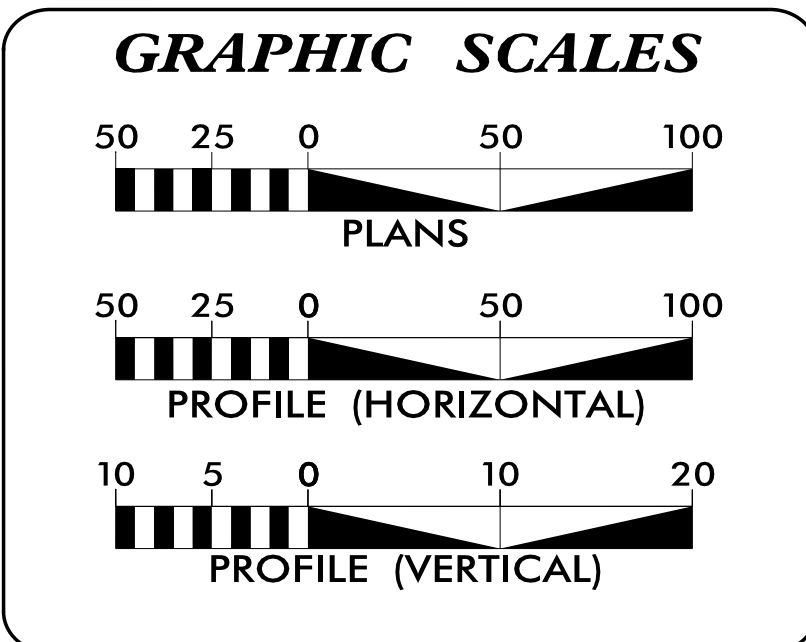

INDEX OF SHEETS

SHEET NO.:	DESCRIPTION:
UO-1	TITLE SHEET
UO-2 THRU UO-3	UBO PLAN SHEETS

UTILITY OWNERS WITH CONFLICTS

(A) POWER (DISTRIBUTION) - ENERGY UNITED
(B) COMMUNICATIONS - SURRY TELEPHONE
(C) WATER - DAVIDSON WATER
(D) SEWER - CITY OF WINSTON

PREPARED IN THE OFFICE OF:

Michael Baker
INTERNATIONAL

Michael Baker Engineering, Inc.
8000 Regency Parkway, Suite 600
Cary, NC 27518
919-463-5488

Brandy Creech	UTILITY PROJECT MANAGER
Brandy Creech	PROJECT UTILITY COORDINATOR
Christina Newsome	PROJECT UTILITY TECHNICIAN

**DIVISION OF HIGHWAYS
UTILITIES UNIT**
1555 MAIL SERVICES CENTER
RALEIGH NC 27699-1555
PHONE (919) 707-6690
FAX (919) 250-4151

Donna Jackson, P.E.	UTILITIES REGIONAL ENGINEER
J. T. Yoon, P.E.	UTILITIES ENGINEER
Ed Reams	UTILITIES AREA COORDINATOR
Kyle Pleasant	UTILITIES COORDINATOR

UTILITIES BY OTHERS

NOTE:
ALL UTILITY WORK SHOWN ON THIS SHEET WILL BE DONE BY OTHERS. NO PAYMENT WILL BE MADE TO THE CONTRACTOR FOR UTILITY WORK SHOWN ON THIS SHEET.

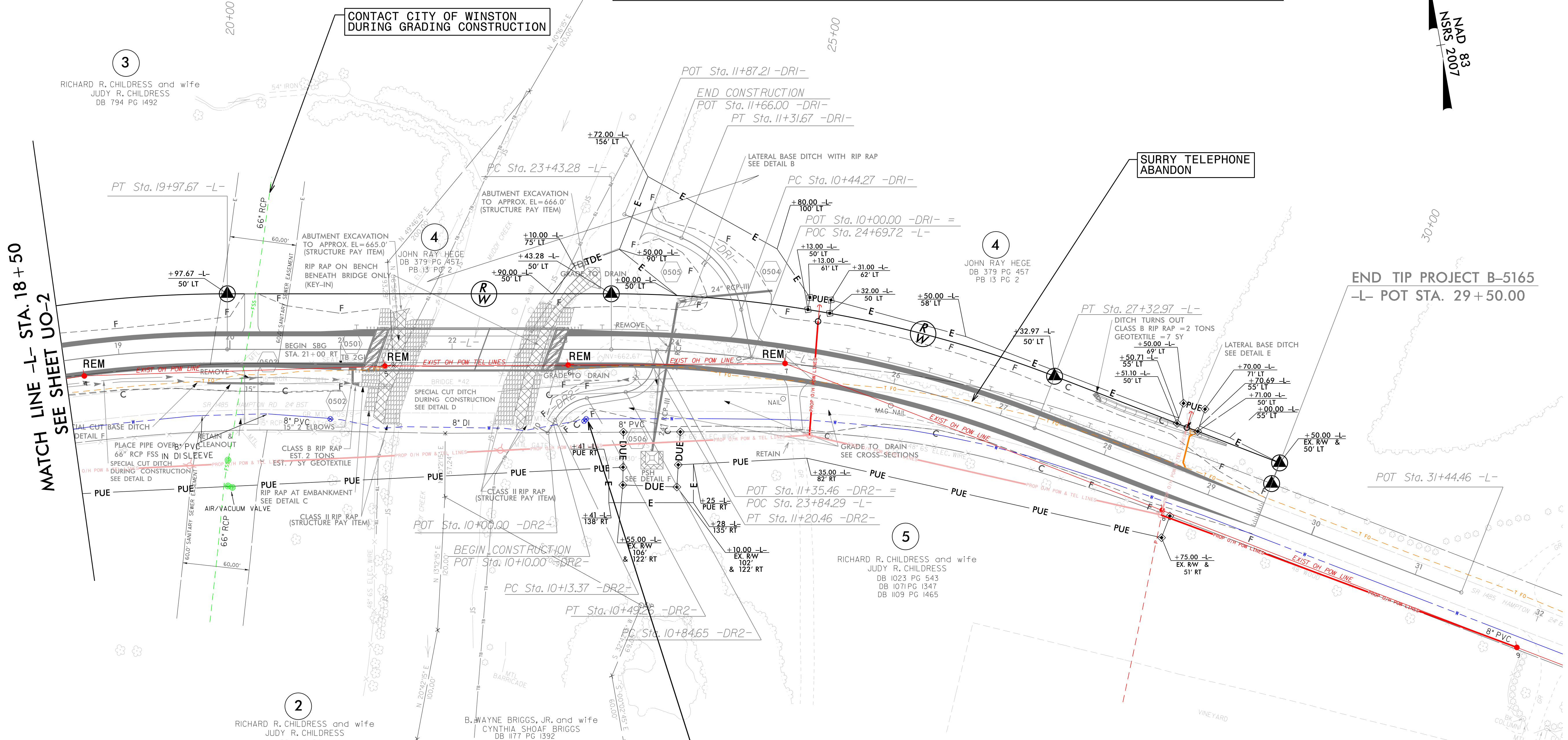
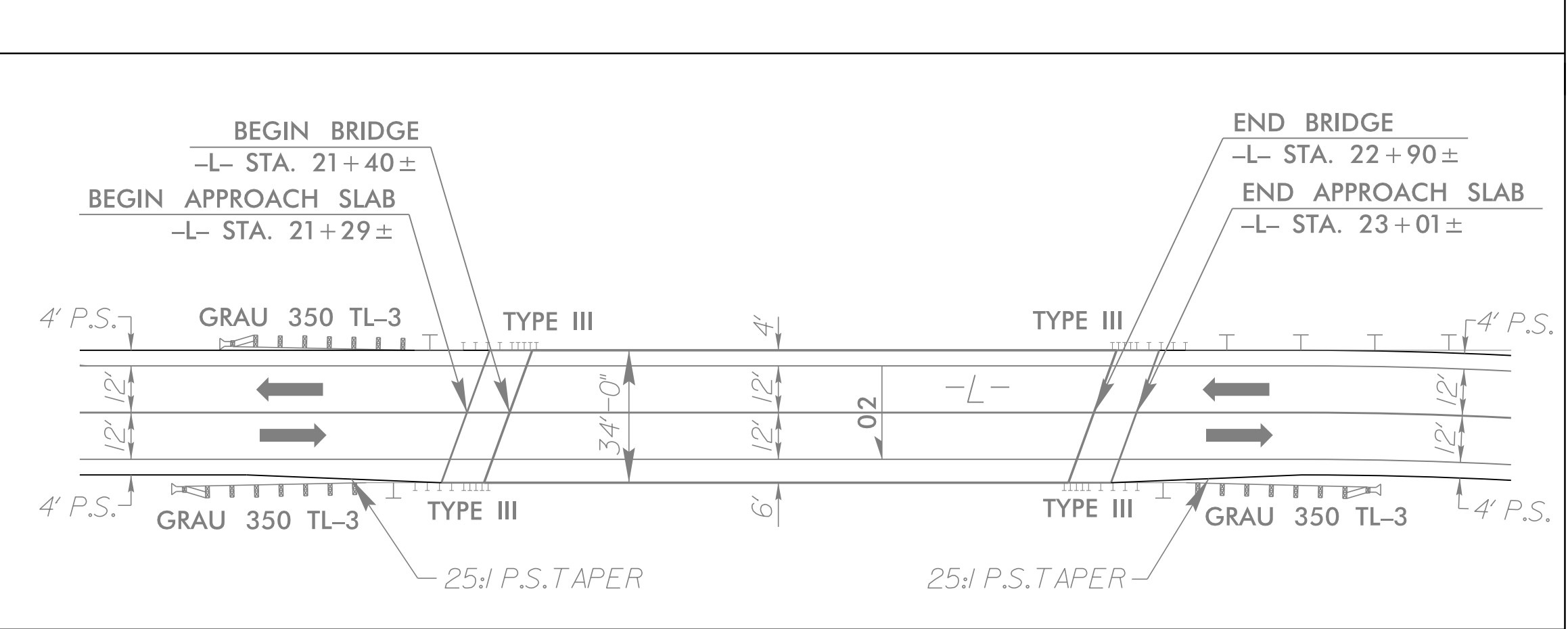

MATCH LINE -L- STA. 18+50
SEE SHEET U0-2

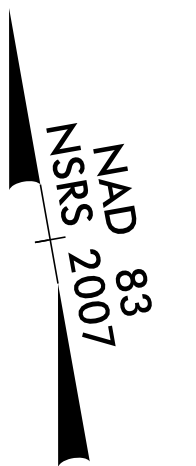

5/14/99
03-FEB-2017 10:23
C:\Coll Center\B5165\Utilities\B5165.ut.rd\5_U03_psh.dgn
Davidson County\Utilities\B5165.ut.rd\5_U03_psh.dgn

Michael Baker
INTERNATIONAL
Michael Baker Engineering, Inc.
8000 Regency Parkway, Suite 600
Cary, NC 27518
919-463-5488