

### UTILITIES BY OTHERS

NOTE:  
ALL UTILITY WORK SHOWN ON THIS SHEET WILL BE DONE BY OTHERS. NO PAYMENT WILL BE MADE TO THE CONTRACTOR FOR UTILITY WORK SHOWN ON THIS SHEET.

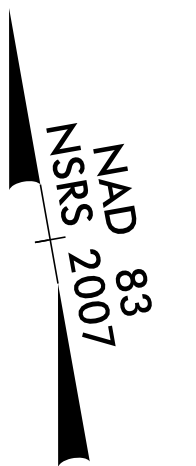
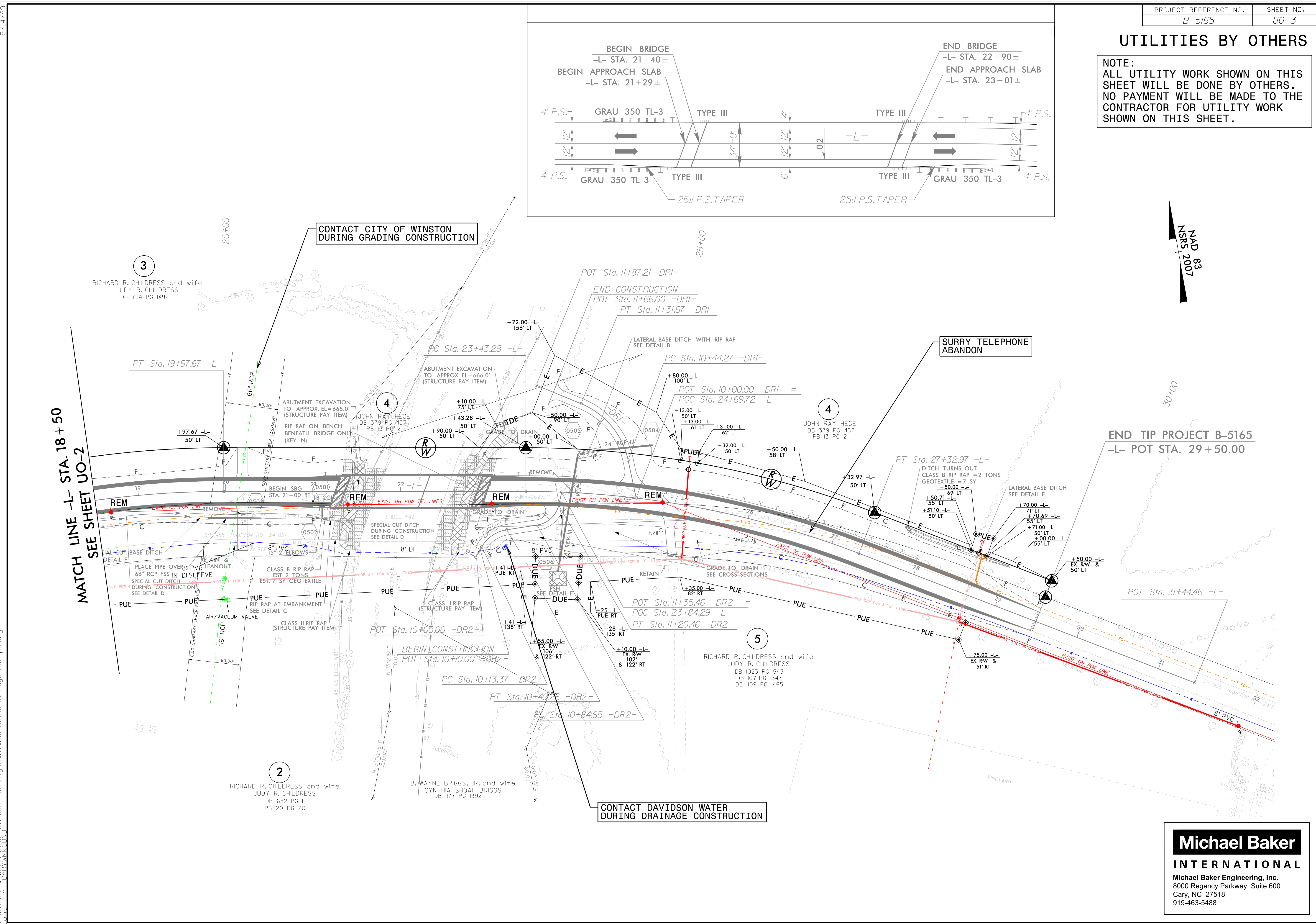
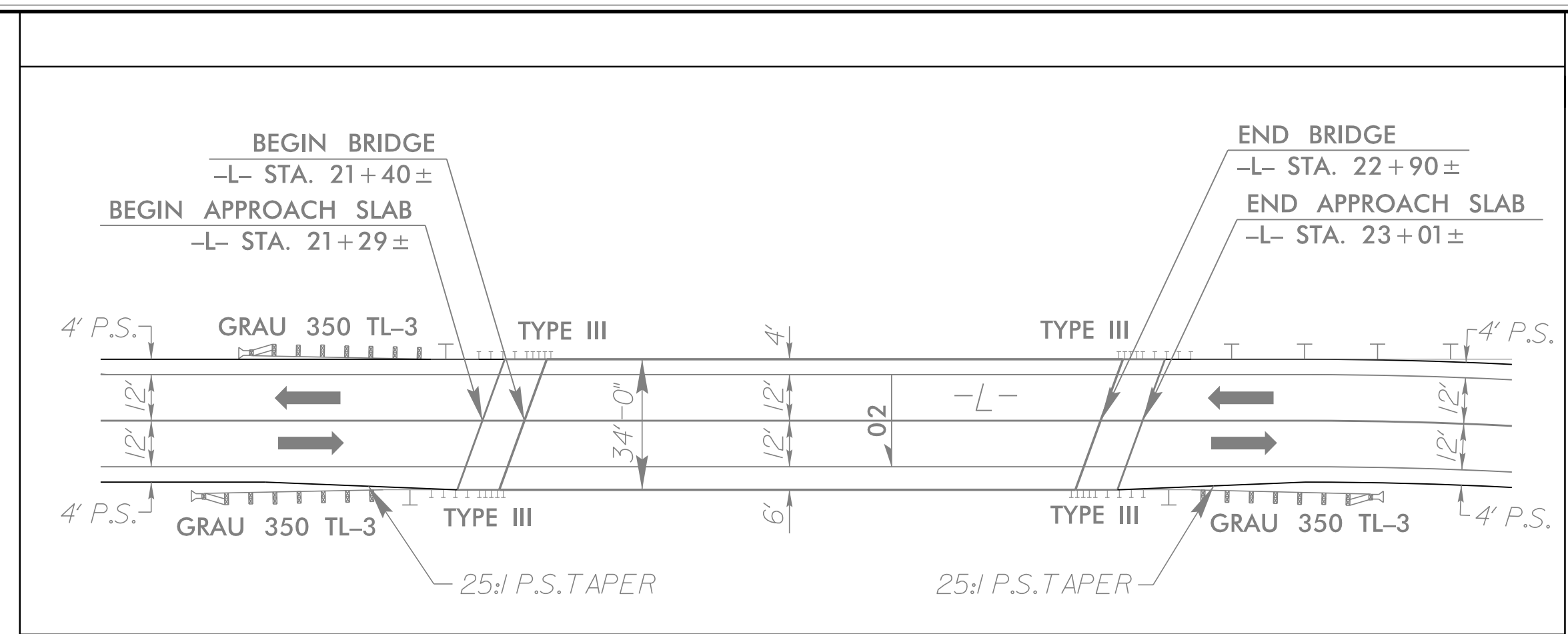

**Michael Baker**  
INTERNATIONAL  
Michael Baker Engineering, Inc.  
8000 Regency Parkway, Suite 600  
Cary, NC 27518  
919-463-5488

5/14/99  
03-FEB-2017 10:23  
C:\Coll Center\B5165\Utilities\B5165.ut.ut.rdy5\_U03\_psh.dgn  
Davidson County\Utilities\B5165.ut.ut.rdy5\_U03\_psh.dgn