

MASTER RADIO LOCATION

**US 70
AT WALMART ENTRANCE
SIG. INV. #02-0873**

Notes:
Unused fibers left coiled and stored in splice tray.
Unused Buffer Tubes left coiled and stored in splice tray.

LEGEND
X = FUSION SPICE

COLOR CODE TIA/EIA 598-A	
(1) BLUE	(7) RED
(2) ORANGE	(8) BLACK
(3) GREEN	(9) YELLOW
(4) BROWN	(10) VIOLET
(5) SLATE	(11) ROSE
(6) WHITE	(12) AQUA

GENERAL NOTE:
1. NOTIFY THE NCDOT DEPUTY DIVISION TRAFFIC ENGINEER, MARY MOORE, PE, AT (252)439-2800, FIVE (5) DAYS PRIOR TO BEGINNING WORK ON WIRELESS COMMUNICATIONS SYSTEM. NOTIFY THE NCDOT DEPUTY DIVISION TRAFFIC ENGINEER AFTER ALL WORK IS PERFORMED TO ENSURE THAT ALL COMMUNICATION CIRCUITS ARE FUNCTIONING PROPERLY. ALL WORK IS NOT COMPLETE UNTIL THE SIGNAL SYSTEM IS BACK UP AND OPERATIONAL.

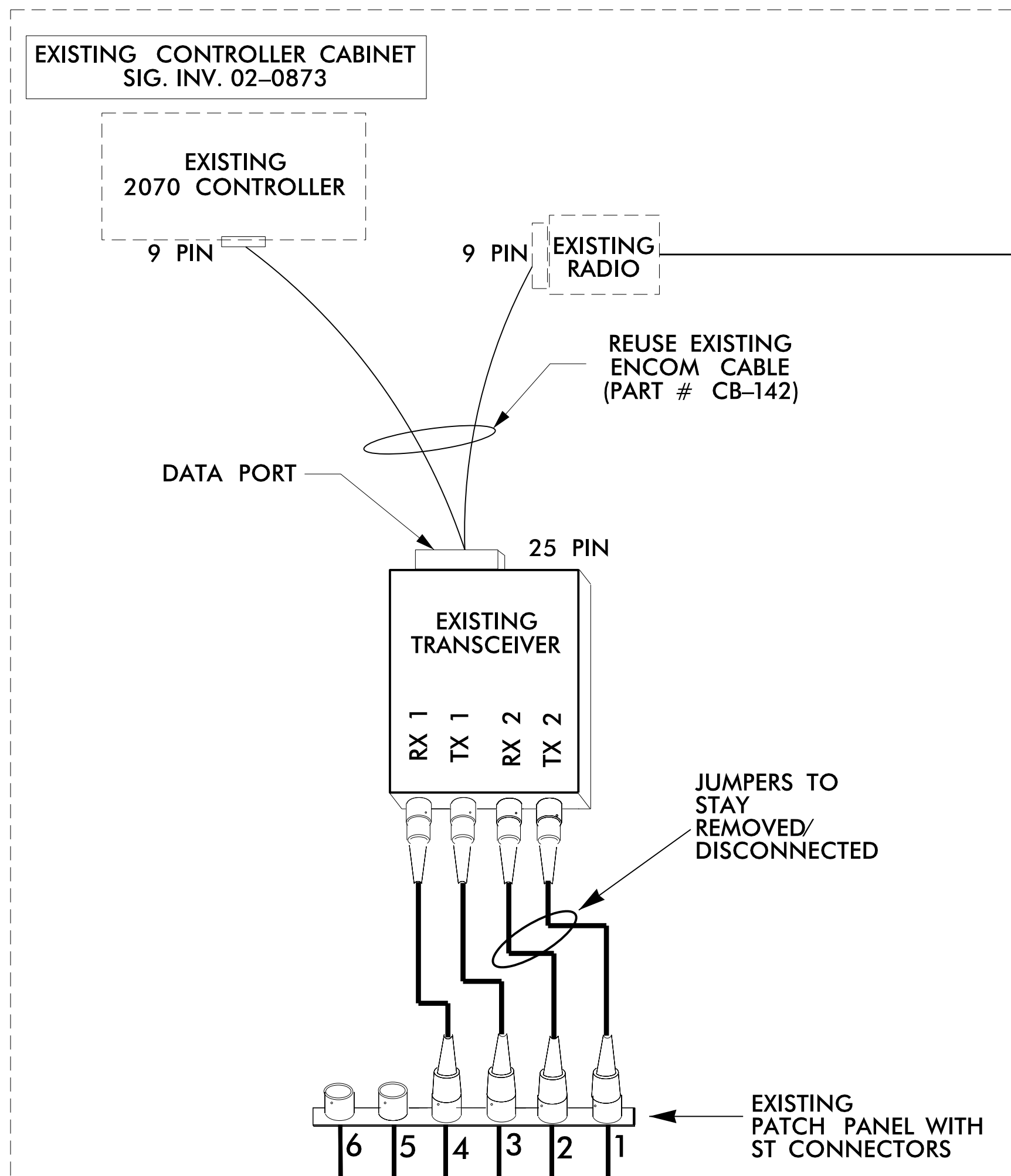

EXISTING 13 DB YAGI ANTENNA

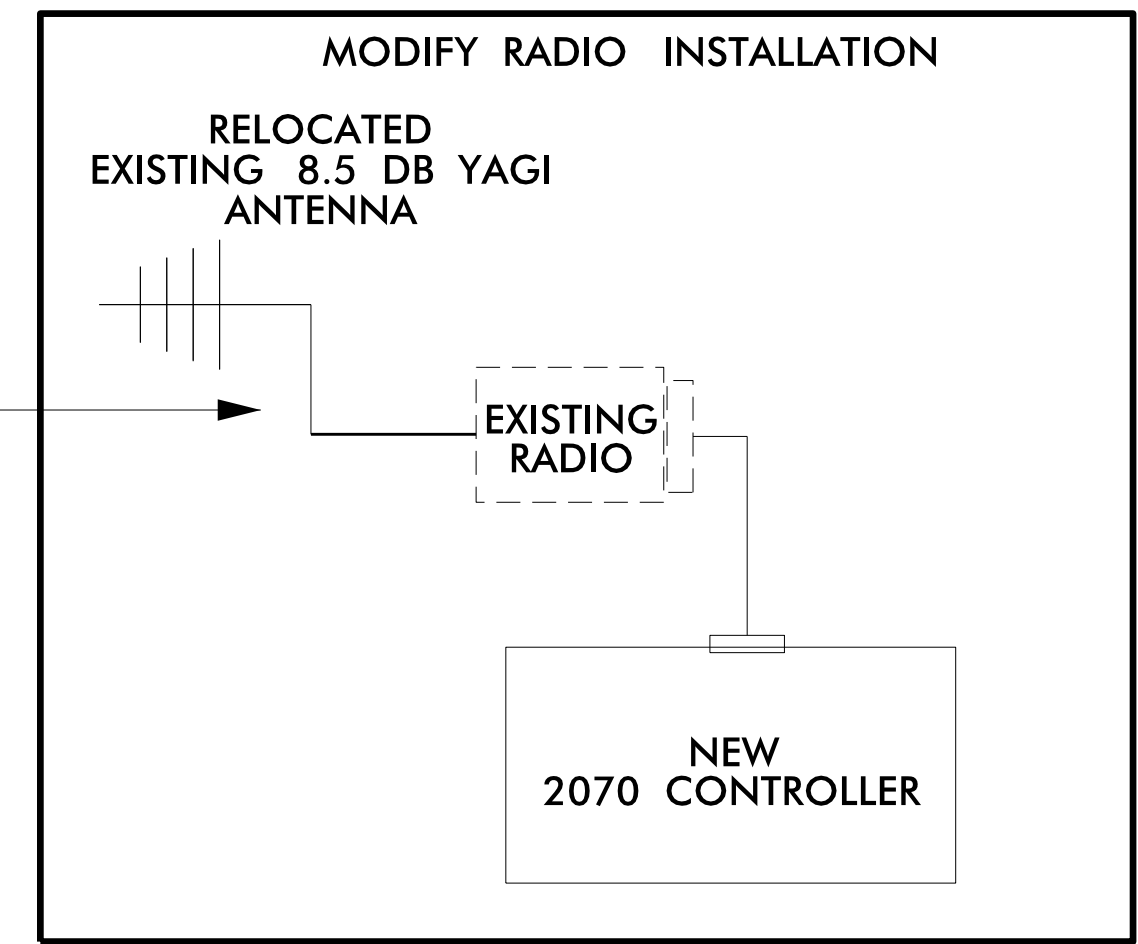

TO 02-0672

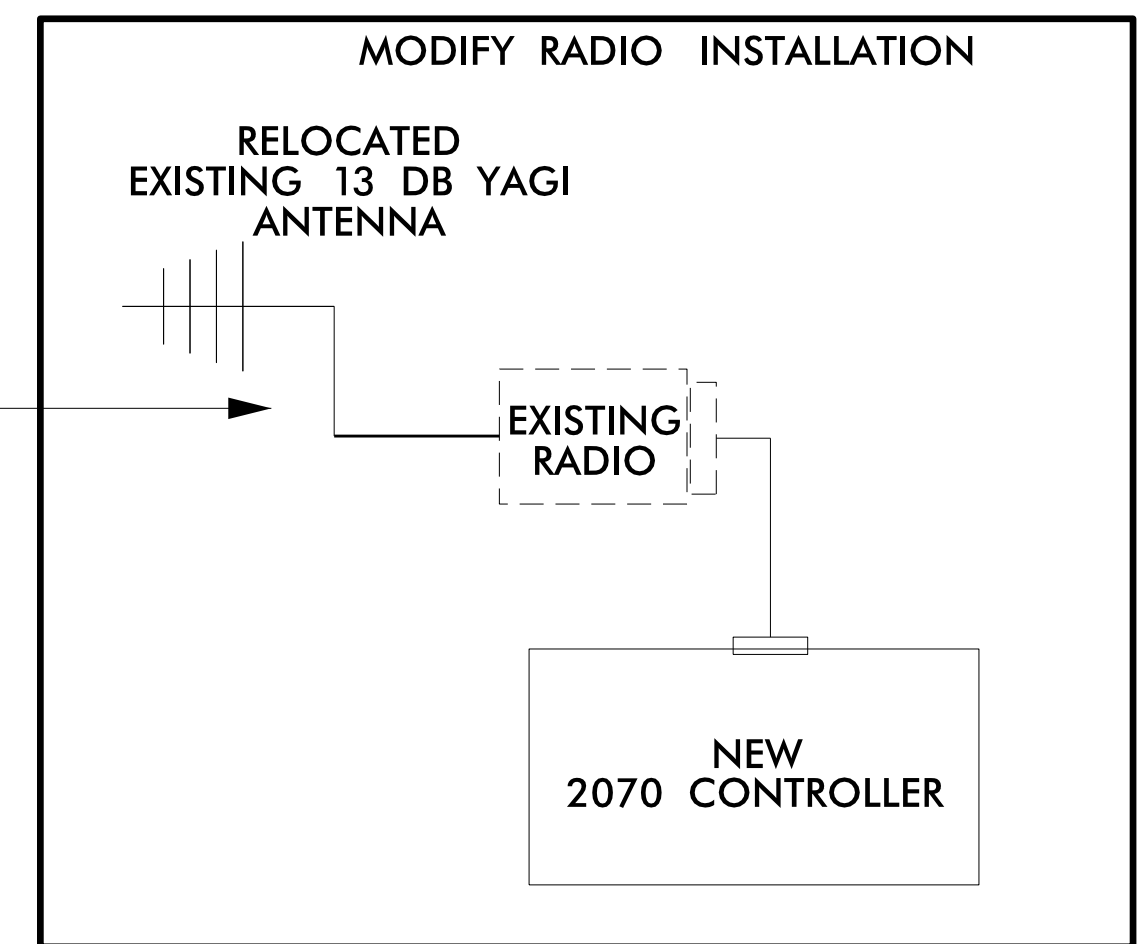

TO 02-0563

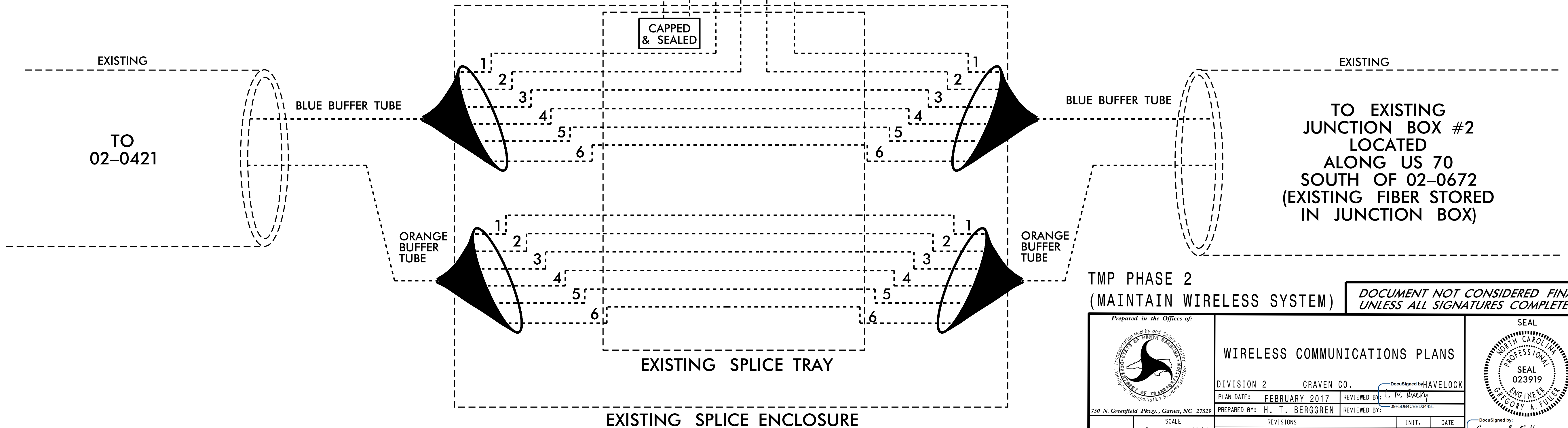

TMP PHASE 2
(MAINTAIN WIRELESS SYSTEM)

DOCUMENT NOT CONSIDERED FINAL
UNLESS ALL SIGNATURES COMPLETED

<p>750 N. Greenfield Pkwy., Garner, NC 27529</p>	<p>WIRELESS COMMUNICATIONS PLANS</p> <p>DIVISION 2 CRAVEN CO.</p> <p>PLAN DATE: FEBRUARY 2017</p> <p>PREPARED BY: H. T. BERGGREN</p>		<p>SEAL 023919</p> <p>ENGINEER</p> <p>GREGORY A. FULLER</p>
	<p>REVISIONS</p> <p>INIT. DATE</p>		
<p>SCALE: NONE</p>	<p>DocuSigned by: HAVELock</p> <p>DocuSigned by: Gregory A. Fuller</p>		<p>DATE: 2/15/2017</p>