

Welded Ring Stiffened Mast Arm Connection

PROJECT ID. NO.

SHEET NO.

R-5516

Sig.M5

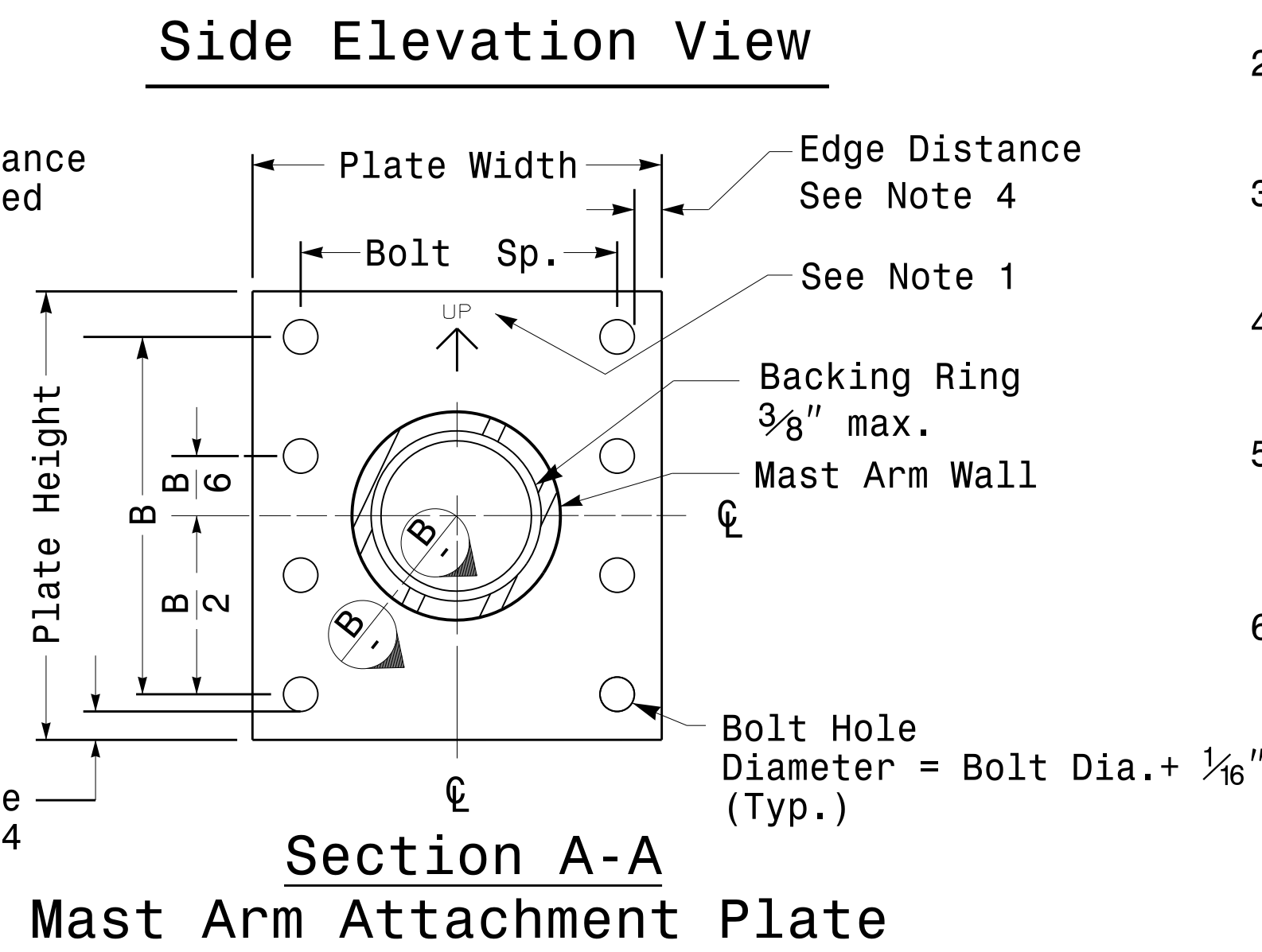
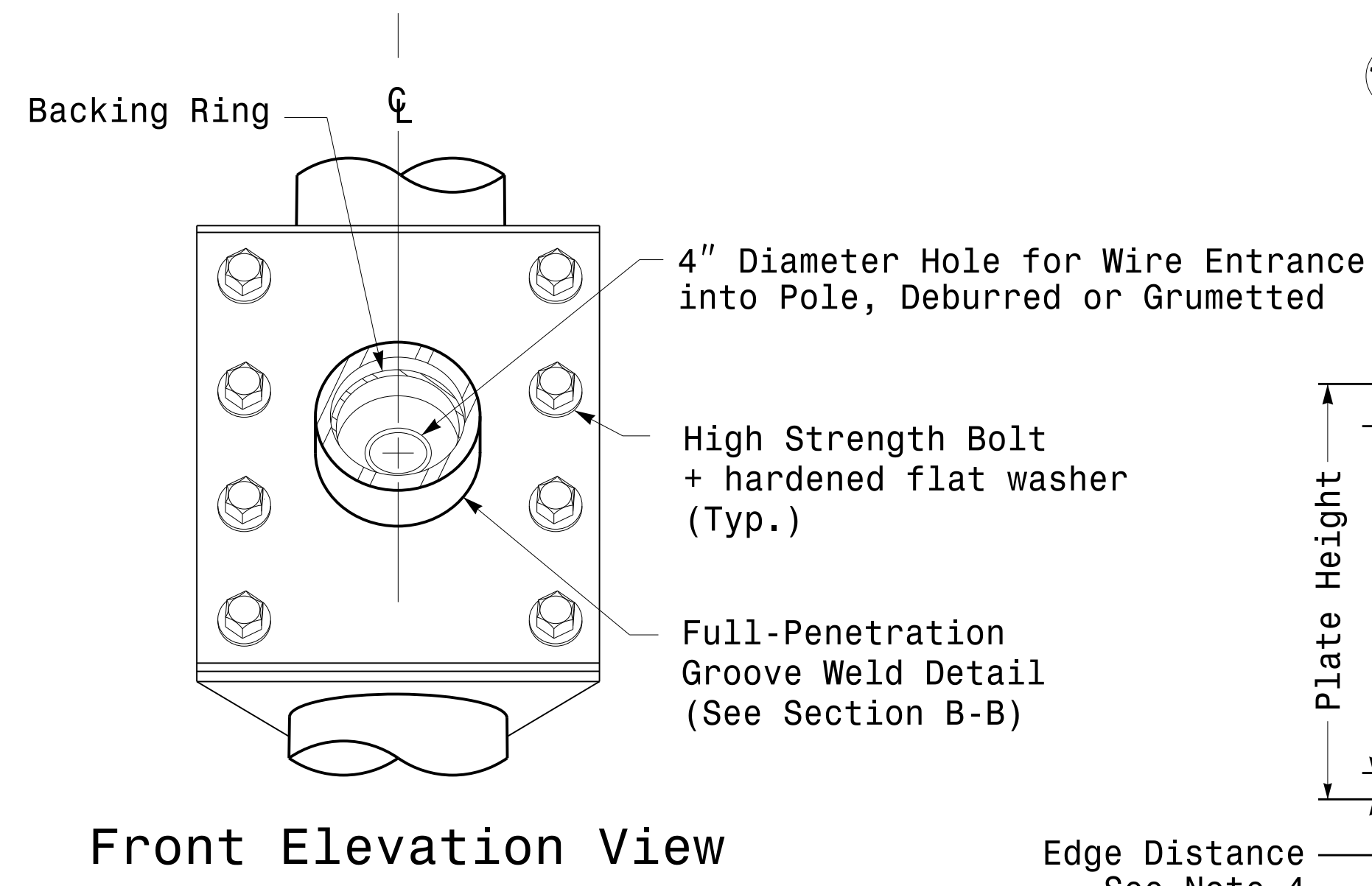
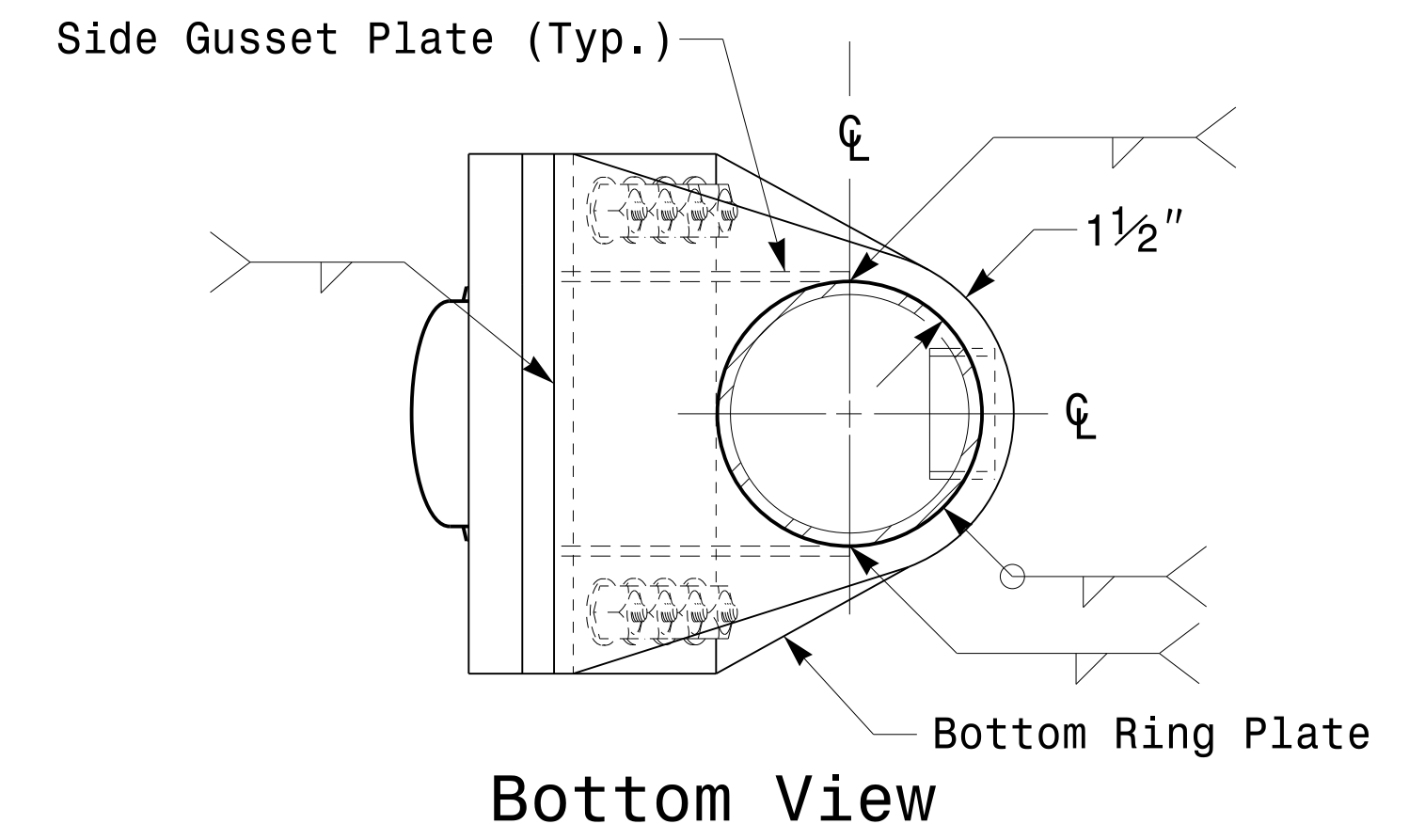
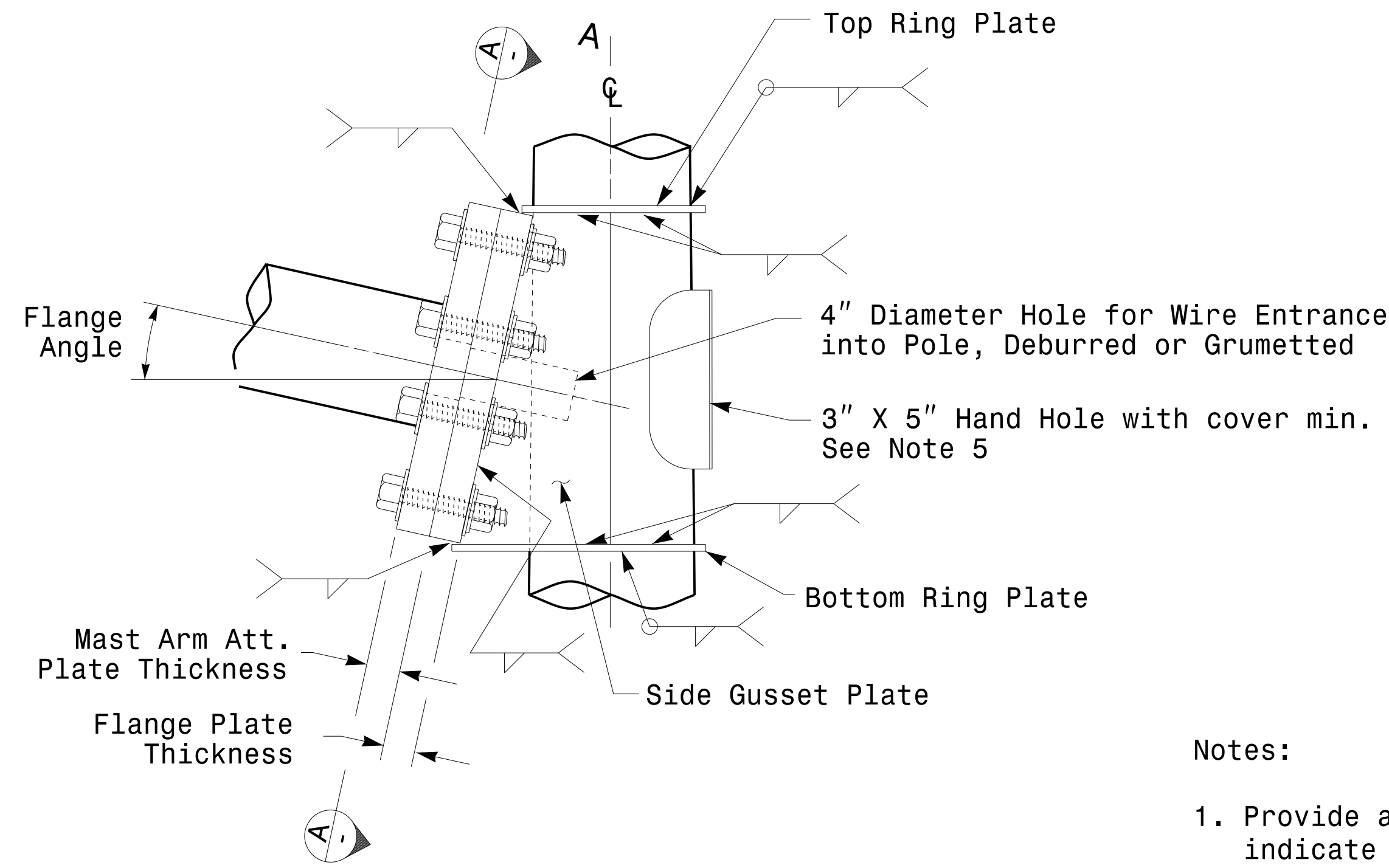
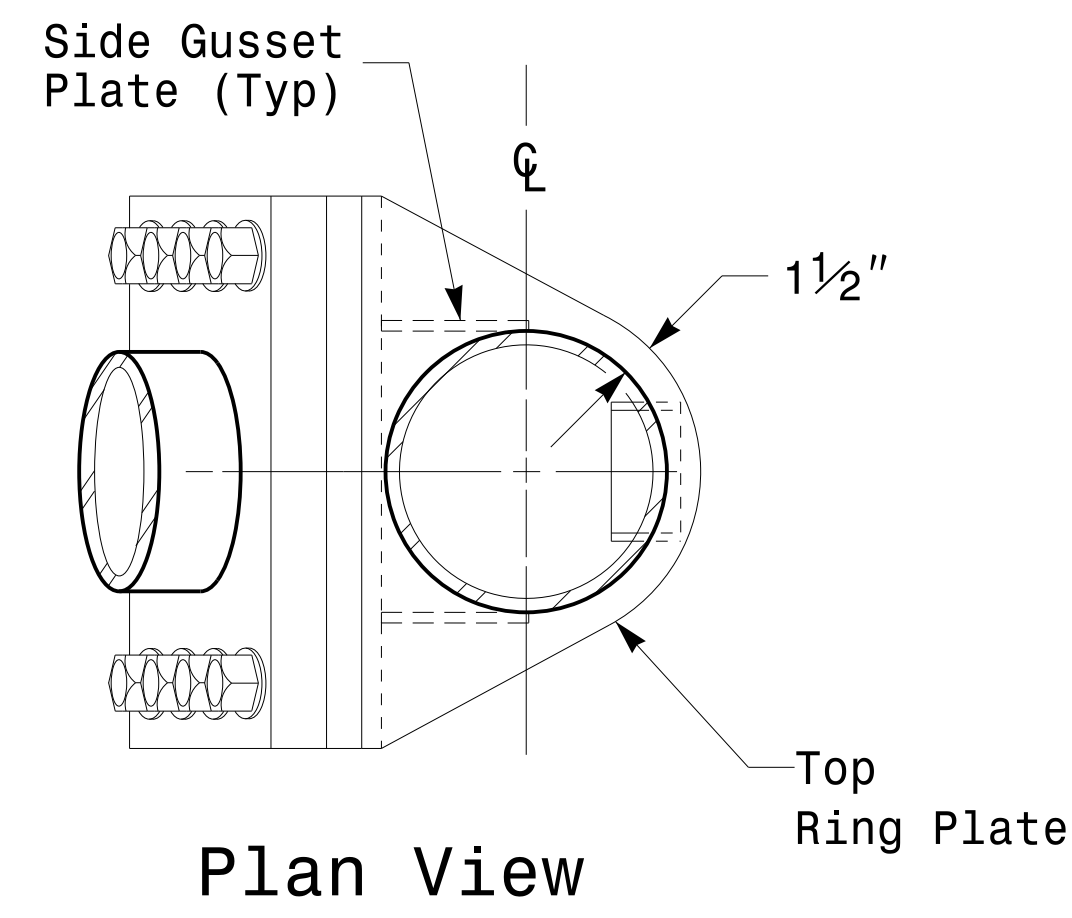

Notes:

1. Provide a permanent means of identification above the mast arm to indicate proper attachment orientation of the mast arm.
2. Designer will determine the size of all structural components, plates, fasteners, and welds shown unless they are already specified.
3. Fabricator is responsible for providing appropriate holes at drainage points to drain galvanizing materials.
4. For minimum edge distance follow AISC Table J3.4 and J3.5. For nominal bolt hole size use Table J3.3.
5. Provide upper handhole as necessary when shaft extensions are required for luminaire arms or camera. For poles without luminaires/camera, wiring can be done through the top of pole.
6. Allowable range of flange tilt angle will vary from 0° to as required.

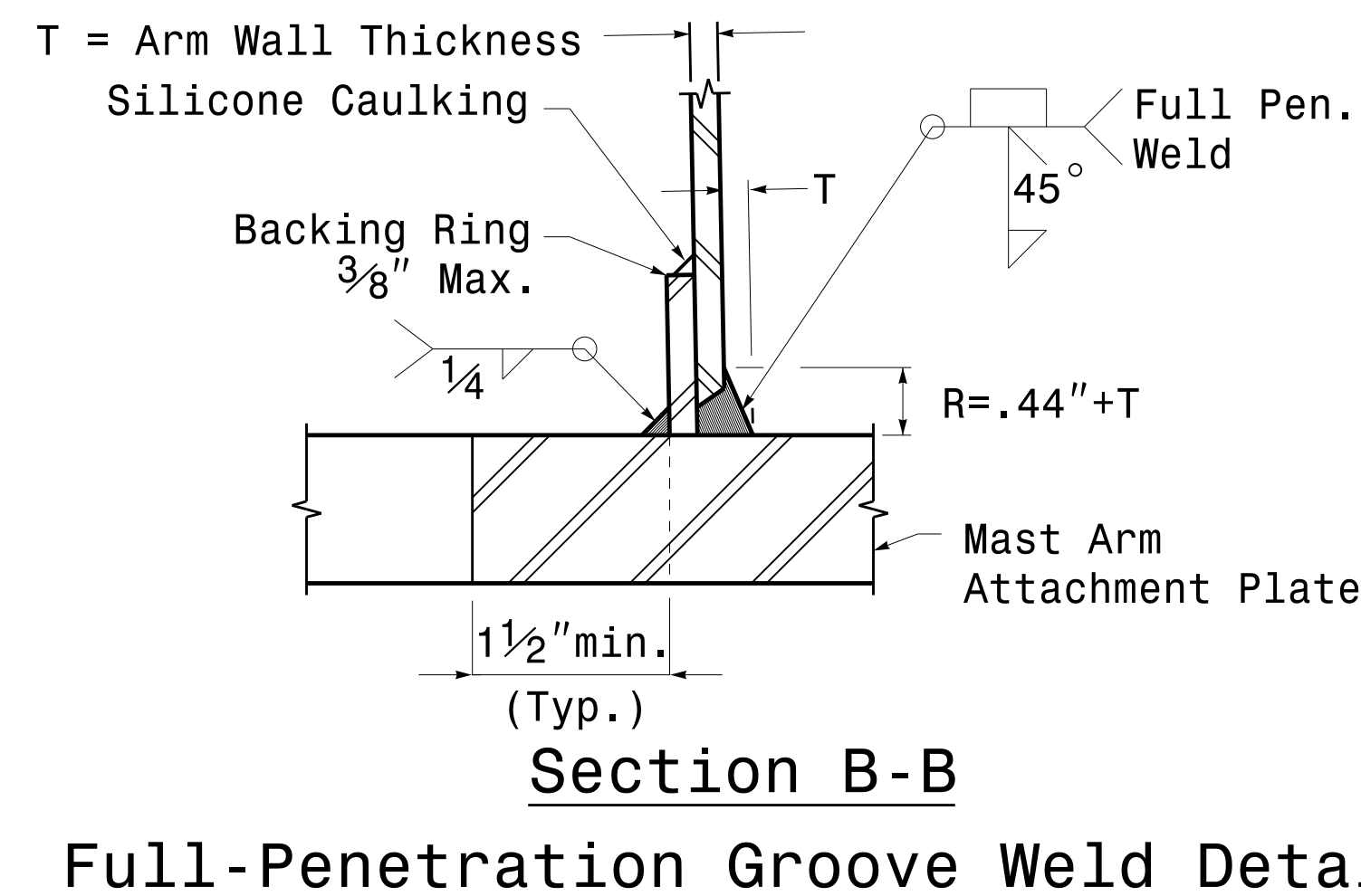
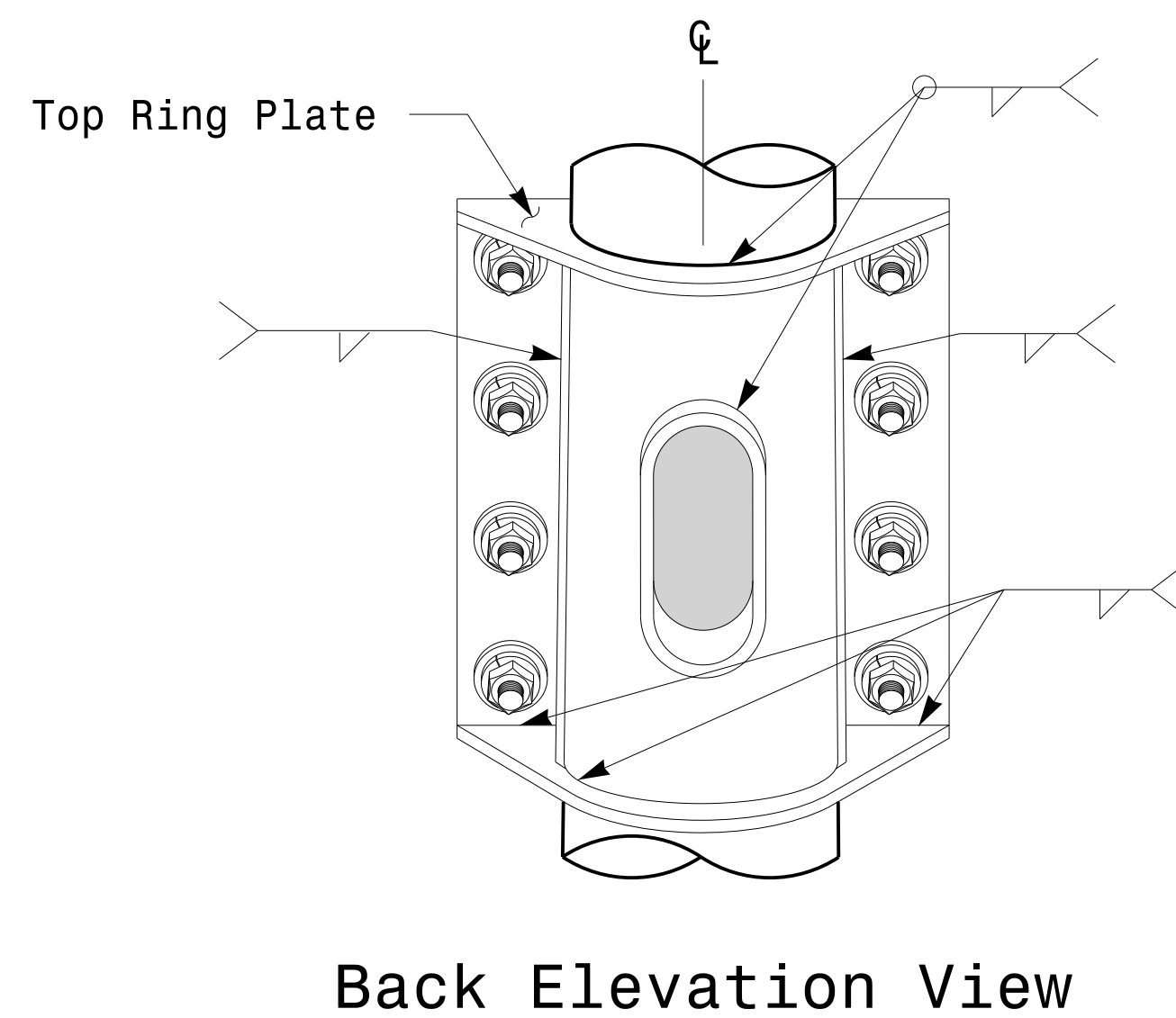

Prepared in the Offices of:

750 N. Greenfield Pkwy, Garner, NC 27529

SCALE: 0 NA NONE

Typical Fabrication Details For Mast Arm Connection To Pole

PLAN DATE: FEBRUARY 2016	DESIGNED BY: C.F. ANDREWS
PREPARED BY: N. BITTING	REVIEWED BY: D.C. SARKAR
REVISIONS	INIT. DATE

SEAL

DocuSigned by: Debesh C. Sarkar

2/17/2016

DATE

Fabrication Details - Mast Arm Connection

17-FEB-2016 16:06 T:\CSG\W115\SigM5.dgn Design Section\Eastern Region\W115\SigM5.dgn Connection Fabrication Detail\Mast Arm Pole.dgn