

**This electronic collection of documents is provided
for the convenience of the user
and is Not a Certified Document –**

**The documents contained herein were originally issued
and sealed by the individuals whose names and license
numbers appear on each page, on the dates appearing
with their signature on that page.**

**This file or an individual page
shall not be considered a certified document.**

09.08/99

See Sheet 1-A For Index of Sheets

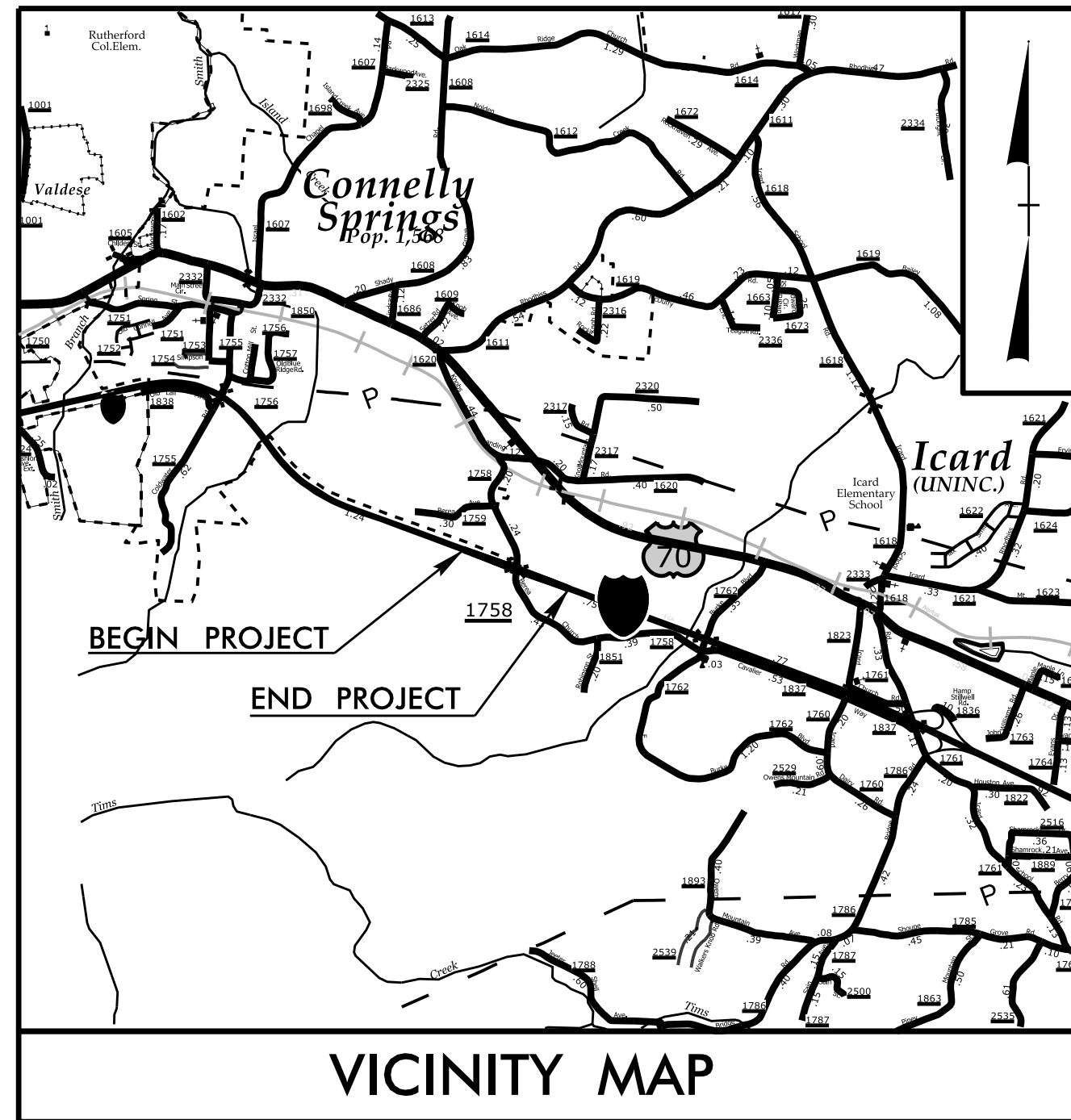

TIP PROJECT: B-4447

STATE OF NORTH CAROLINA
DIVISION OF HIGHWAYS

**UTILITIES BY OTHERS PLANS
BURKE COUNTY**

**LOCATION: BRIDGE NO. 160 & 162 ON I-40 OVER
SR 1758 (BEREA CHURCH ROAD)**

TYPE OF WORK: DISTRIBUTION POWER RELOCATION

T.I.P. NO.	SHEET NO.
B-4447	UO-1

NOTE:
ALL UTILITY WORK SHOWN ON THIS SHEET IS DONE BY OTHERS.
NO PAYMENT WILL BE MADE TO THE CONTRACTOR FOR UTILITY WORK SHOWN ON THIS SHEET.

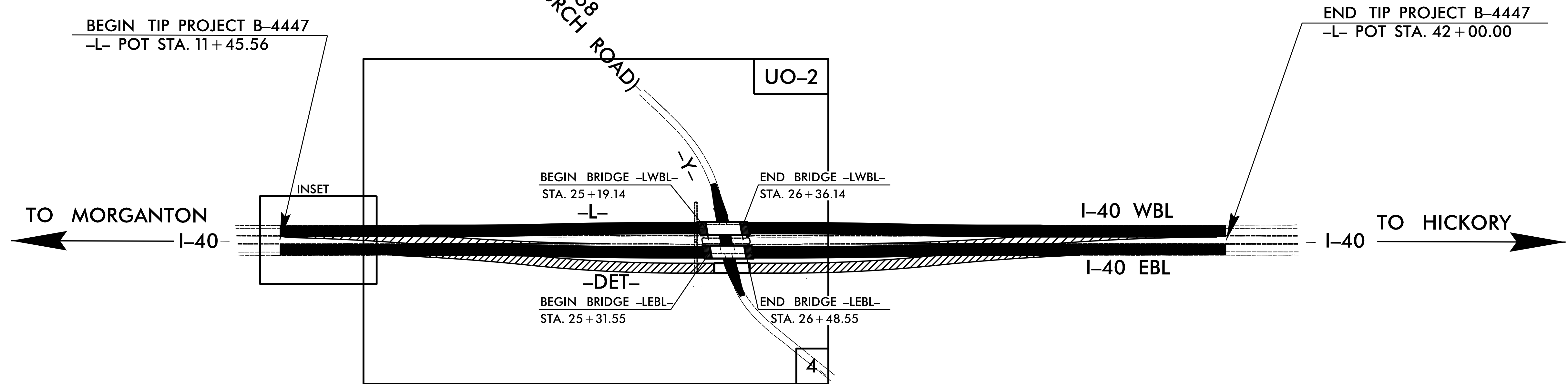
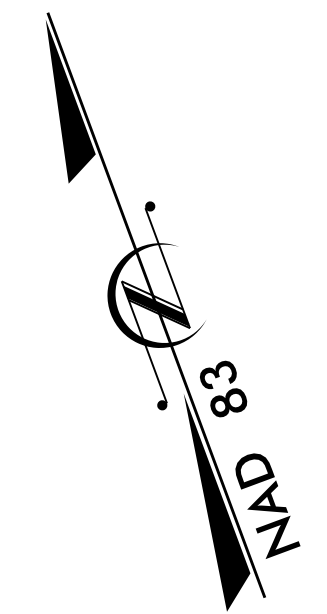

GRAPHIC SCALES

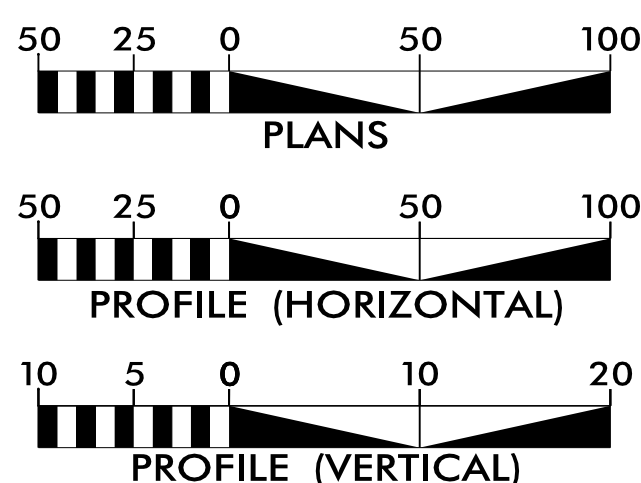

INDEX OF SHEETS

SHEET NO.:	DESCRIPTION:
UO-1	TITLE SHEET
UO-02	UBO PLAN SHEET

UTILITY OWNERS WITH CONFLICTS

- (A) POWER - DUKE ENERGY
- (B) WATER - ICARD WATER

PREPARED IN THE OFFICE OF:

M A Engineering NC License: F-0160
Consultants, Inc. Cary, NC 27511
598 East Chatham Street Suite 137 Phone: 919.297.0220 Fax: 919.297.0221

WEBB WHITE PROJECT UTILITY COORDINATOR

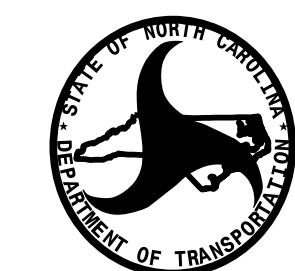

**DIVISION OF HIGHWAYS
UTILITIES UNIT**
1555 MAIL SERVICES CENTER
RALEIGH, NC 27699-1555
PHONE (919) 707-6690
FAX (919) 250-4151

CARL BARCLAY, PE WESTERN UTILITIES MANAGER
JAMES SWINSON UTILITIES ENGINEER
AMY DUPREE WESTERN COORDINATOR
TODD LAPHAM UTILITIES COORDINATOR

3/2/2017
E:\JOBS\0659\089\B4447\Utilities\B4447_ut_tsh_u01_psh.dgn
3:58:41 PM

