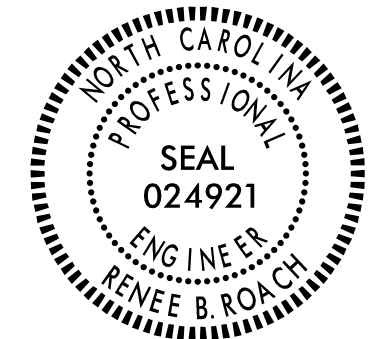

**This electronic collection of documents is provided
for the convenience of the user
and is Not a Certified Document –**

**The documents contained herein were originally issued
and sealed by the individuals whose names and license
numbers appear on each page, on the dates appearing
with their signature on that page.**

**This file or an individual page
shall not be considered a certified document.**

TIP NO.	SHEET NO.
B-4447	PMP-1
APPROVED: <i>rene roach</i> <small>Documented by B309627CF48400</small>	
DATE: 3/13/2017	
SEAL	
	
DOCUMENT NOT CONSIDERED FINAL UNLESS ALL SIGNATURES COMPLETED	

**STATE OF NORTH CAROLINA
DEPARTMENT OF TRANSPORTATION**

**PAVEMENT MARKING PLAN
BURKE COUNTY**

**LOCATION: BRIDGES 160 AND 162 ON I-40 OVER SR 1758
(BEREA CHURCH ROAD)**

T.I.P.: B-4447

CONTRACT: C203935

ROADWAY STANDARD DRAWING

THE FOLLOWING ROADWAY STANDARDS AS APPEAR IN "ROADWAY STANDARD DRAWINGS" - PROJECT SERVICES UNIT - N.C. DEPARTMENT OF TRANSPORTATION - RALEIGH, N.C., DATED JANUARY 2012 ARE APPLICABLE TO THIS PROJECT AND BY REFERENCE HEREBY ARE CONSIDERED A PART OF THESE PLANS:

STD. NO.	TITLE
1205.01	PAVEMENT MARKINGS - LINE TYPES AND OFFSETS
1205.02	PAVEMENT MARKINGS - TWO-LANE AND MULTILANE ROADWAYS
1205.12	PAVEMENT MARKINGS - BRIDGES
1250.01	RAISED PAVEMENT MARKERS - INSTALLATION SPACING
1251.01	RAISED PAVEMENT MARKERS - PERMANENT AND TEMPORARY
1253.01	RAISED PAVEMENT MARKERS - SNOWPLOWABLE
1261.01	GUARDRAIL AND BARRIER DELINEATORS - INSTALLATION SPACING
1261.02	GUARDRAIL AND BARRIER DELINEATORS - TYPES AND MOUNTING
1262.01	GUARDRAIL END DELINEATION

**B-4447 PAVEMENT
MARKING SCHEDULE**

SYMB	DESCRIPTION
FINAL PAVEMENT MARKINGS	
POLYUREA (4") Highly Reflective Media	
VA	WHITE EDGELINE
VI	YELLOW DOUBLE CENTER
POLYUREA (6") Highly Reflective Media	
V6	WHITE EDGELINE
V7	YELLOW EDGELINE
VJ	10 FT. WHITE SKIP
MARKERS	
PERMANENT RAISED PAVEMENT MARKERS	
MB	CRYSTAL & RED
SNOWPLOWABLE RAISED PAVEMENT MARKERS	
MF	CRYSTAL & RED

GENERAL NOTES

THE FOLLOWING GENERAL NOTES APPLY AT ALL TIMES FOR THE DURATION OF THE CONSTRUCTION PROJECT, EXCEPT WHEN OTHERWISE NOTED IN THE PLAN, OR DIRECTED BY THE ENGINEER.

- A) INSTALL PAVEMENT MARKINGS AND PAVEMENT MARKERS ON THE FINAL SURFACE AS FOLLOWS:

ROAD NAME	MARKING	MARKER
I-40	POLYUREA WITH HIGHLY REFLECTIVE MEDIA	SNOW PLOWABLE PERMANENT RAISED ON BRIDGE
BEREA CH. RD.	POLYUREA WITH HIGHLY REFLECTIVE MEDIA	NONE

- B) TIE PROPOSED PAVEMENT MARKING LINES TO EXISTING PAVEMENT MARKING LINES.
C) REMOVE/REPLACE ANY CONFLICTING/DAMAGED PAVEMENT MARKINGS AND MARKERS.
D) REMOVE ALL RESIDUE AND SURFACE LAITANCE BY ACCEPTABLE METHODS ON CONCRETE BRIDGE DECKS PRIOR TO PLACING POLYUREA WITH HIGHLY REFLECTIVE MEDIA PAVEMENT MARKING MATERIAL.

INDEX

SHEET NO.	DESCRIPTION
PMP-1	PAVEMENT MARKING PLAN TITLE AND SCHEDULE SHEET
PMP-2-3	PAVEMENT MARKING DETAIL

PLAN PREPARED BY: N.C.D.O.T. SIGNING AND DELINEATION UNIT

KELVIN L. JORDAN SIGNING & DELINEATION REGIONAL ENGINEER

DERRICK H. BEARD SIGNING & DELINEATION PROJECT DESIGN ENGINEER

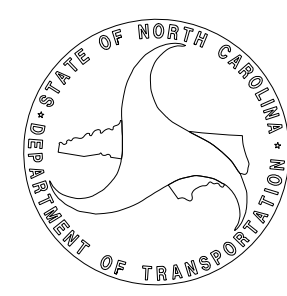

TIP NO.	SHEET NO.
B-4447	PMP-2
APPROVED: <i>Walter Roach</i>	
DATE: 3/13/2017	
SEAL	
DOCUMENT NOT CONSIDERED FINAL UNLESS ALL SIGNATURES COMPLETED	

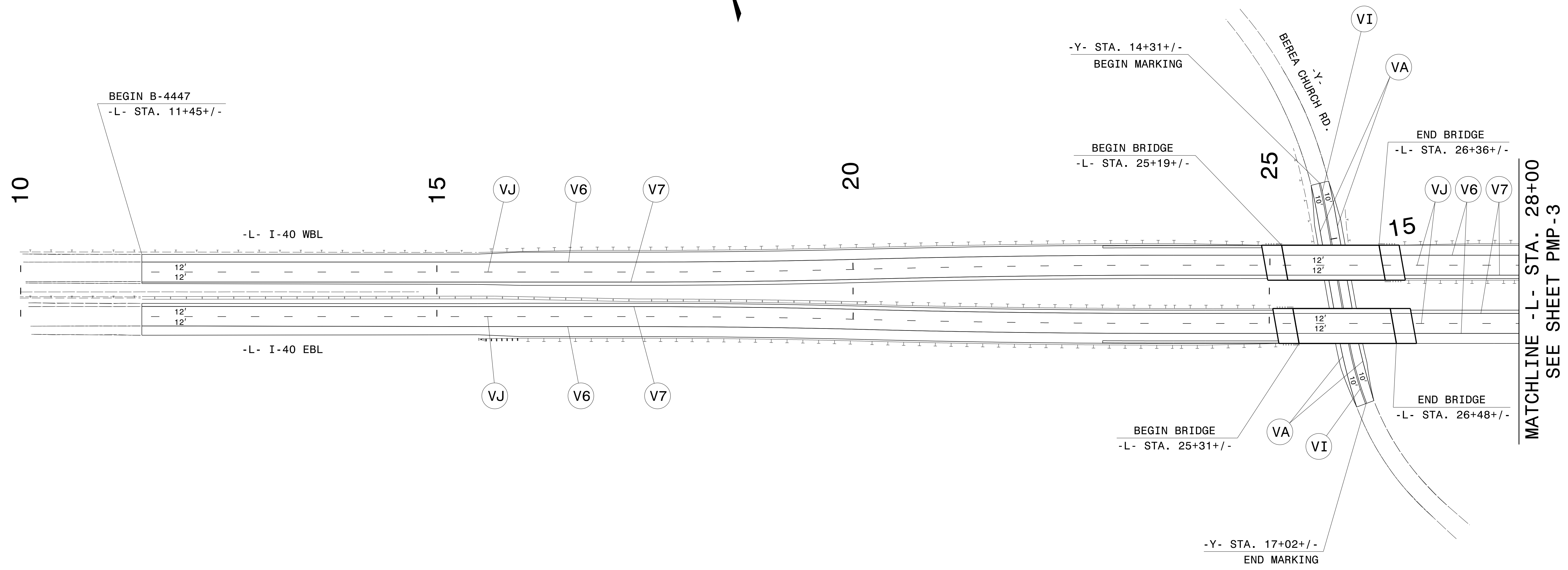
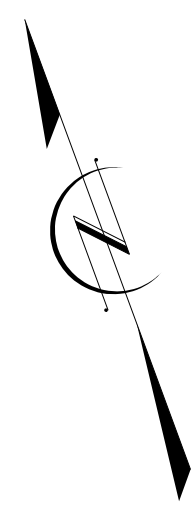

MATCHLINE -L- STA. 28+00
SEE SHEET PMP-3

PAVEMENT MARKING DETAIL

3/13/2017
P:\Projects\B-4447\Traffic\Signing\CADD\PM\B-4447_PMP-2.dgn
User:dhbearf

TIP NO.	SHEET NO.
B - 4447	PMP - 3
APPROVED: <i>rene b. roach</i>	
DATE: 3/13/2017	
SEAL	
DOCUMENT NOT CONSIDERED FINAL UNLESS ALL SIGNATURES COMPLETED	

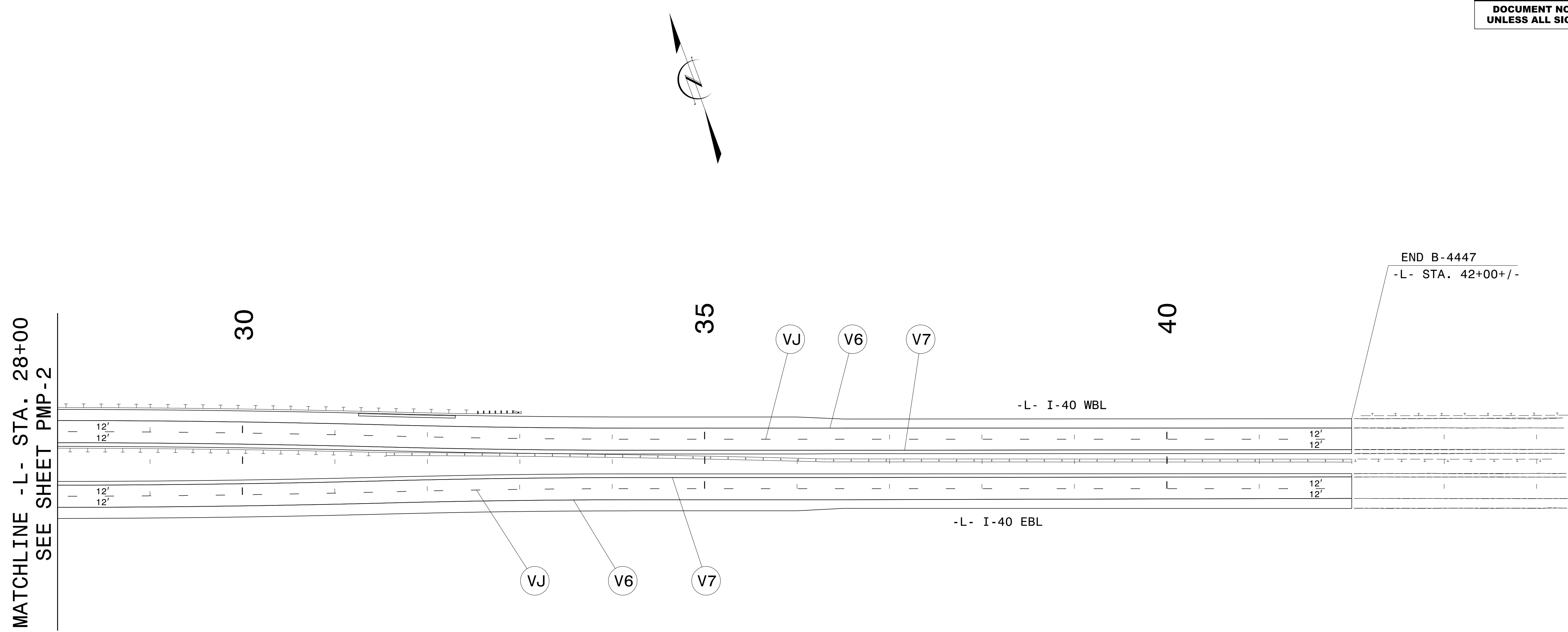

3/13/2017
P:\TIP\Projects-B\B4447\Traffic\Signing\CADD\PM\B-4447_PMP-3.dgn
User:dhbearD

PAVEMENT MARKING DETAIL