

PLAN

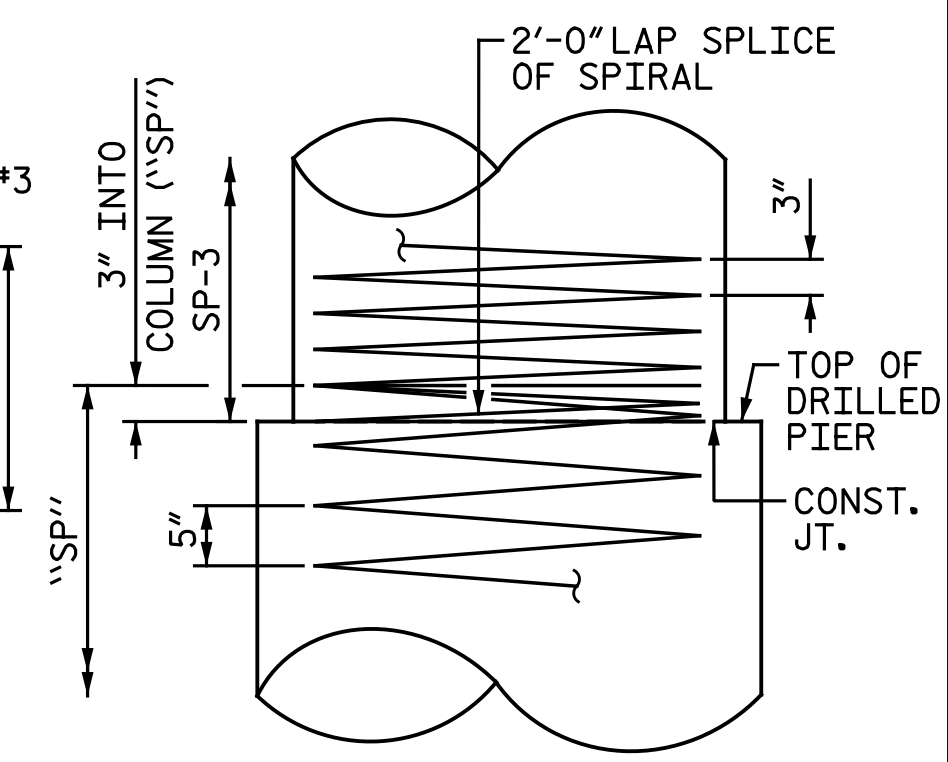

CONSTRUCTION JT. DETAIL

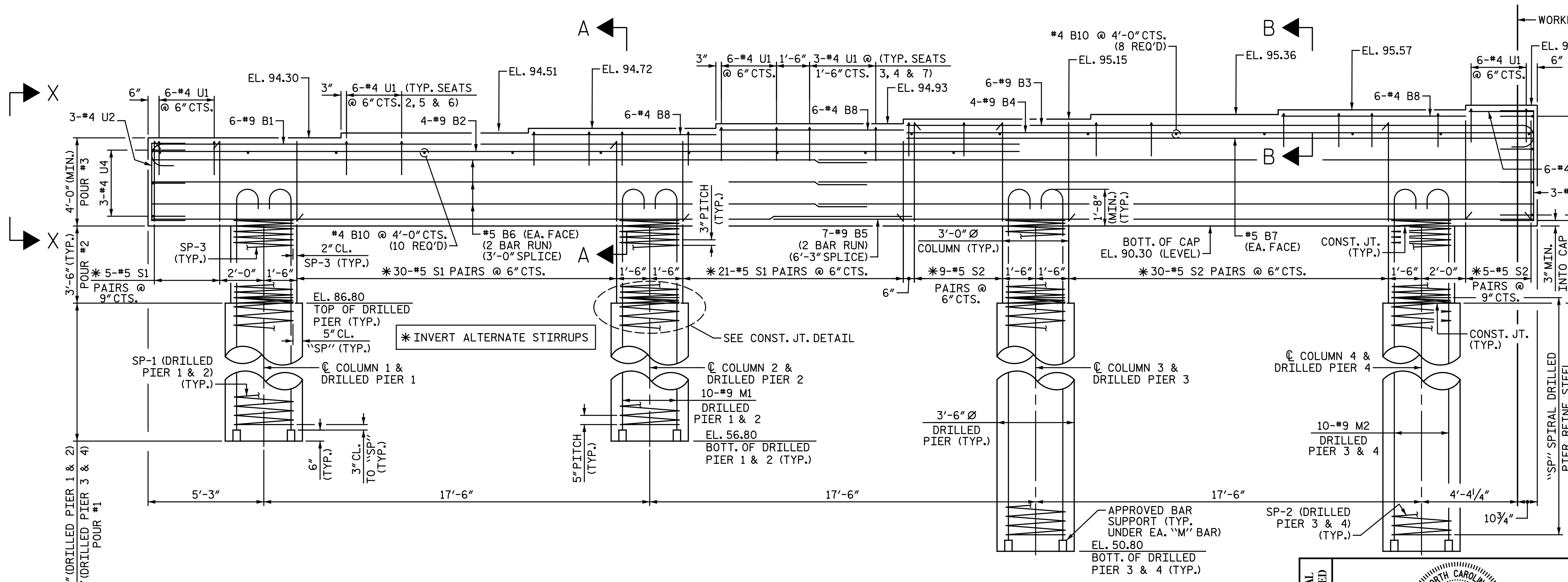

ELEVATION

PROJECT NO. U-3330
NASH COUNTY
 STATION: 61+03.00 -L-

DRAWN BY: M. D. MAYHEW DATE: 11-29-16
 CHECKED BY: A. H. SHARPE DATE: 12-9-16

DOCUMENT NOT CONSIDERED FINAL UNLESS ALL SIGNATURES COMPLETED		STATE OF NORTH CAROLINA DEPARTMENT OF TRANSPORTATION RALEIGH SUBSTRUCTURE BENT 2 STAGE I		SHEET NO. S3-32 TOTAL SHEETS 42
		REVISIONS		
		NO. 1 BY: [Signature] DATE: [Date]	NO. 2 BY: [Signature] DATE: [Date]	

Michael Baker International
 Michael Baker Engineering
 8000 Regency Parkway, Suite 600
 Cary, North Carolina 27518
 NC License No.: F-1084