

PLAN @ END BENT 1

PLAN @ END BENT 2

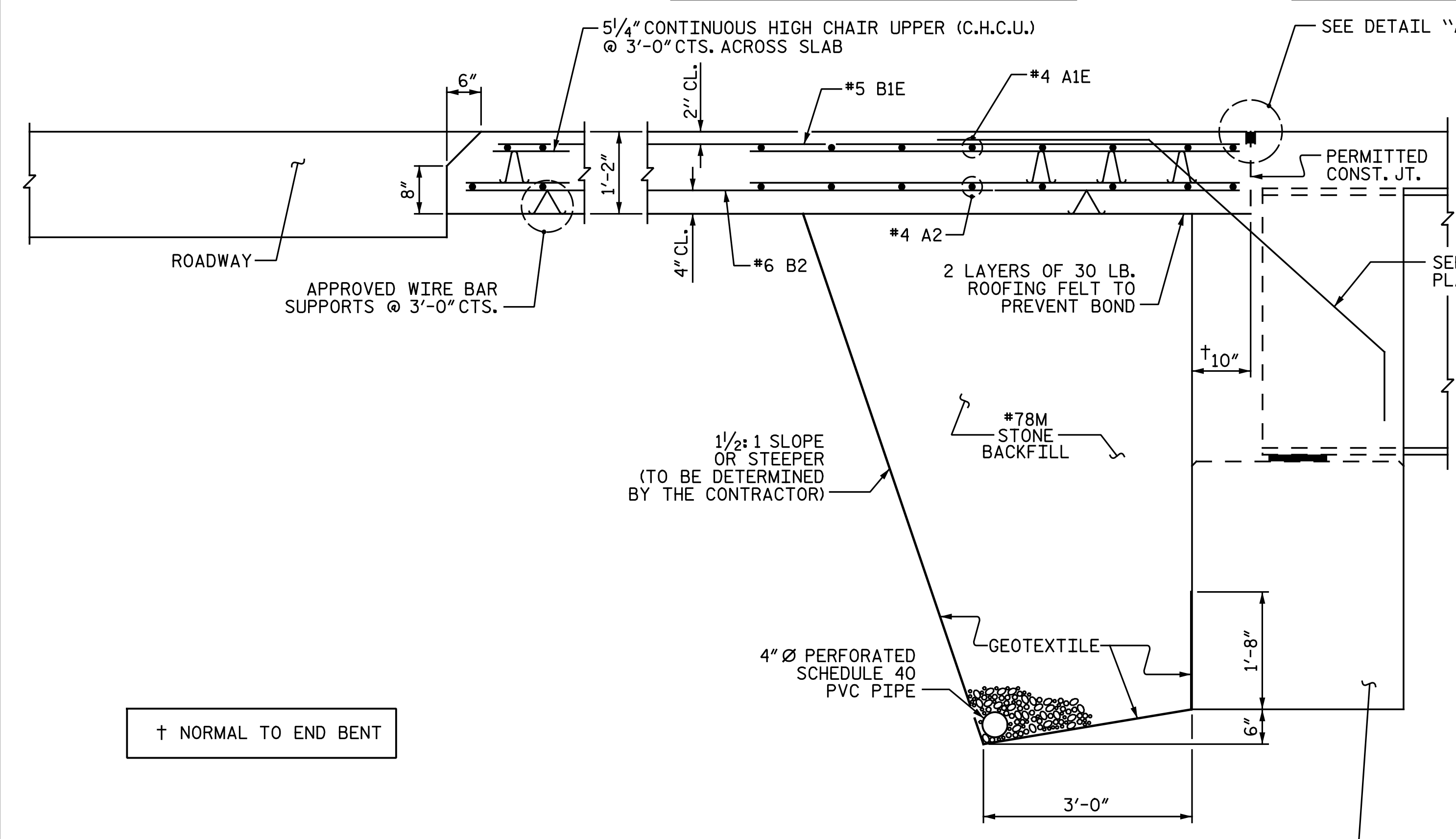

SECTION THRU SLAB

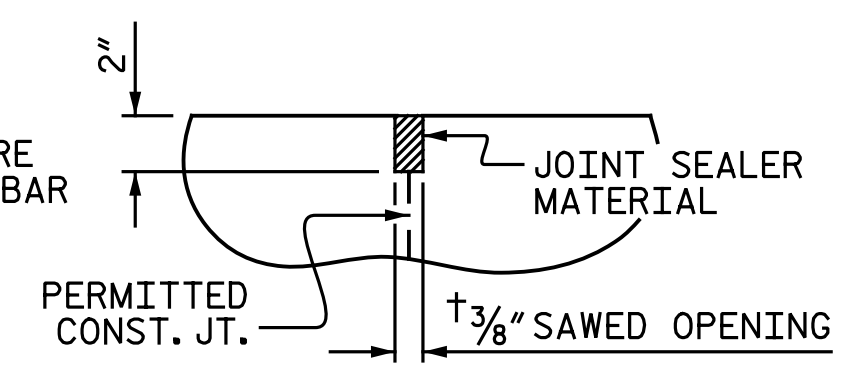

DETAIL "A"

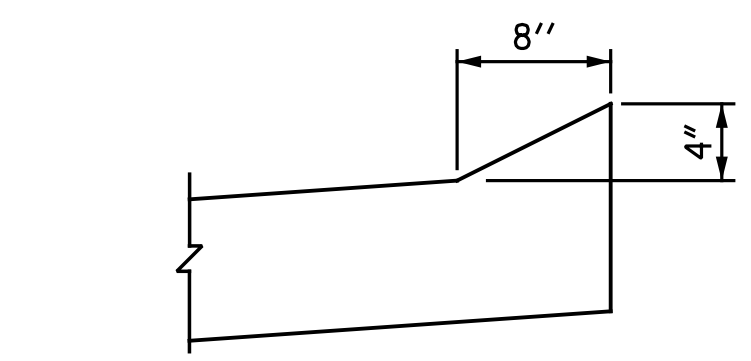

SECTION M-M

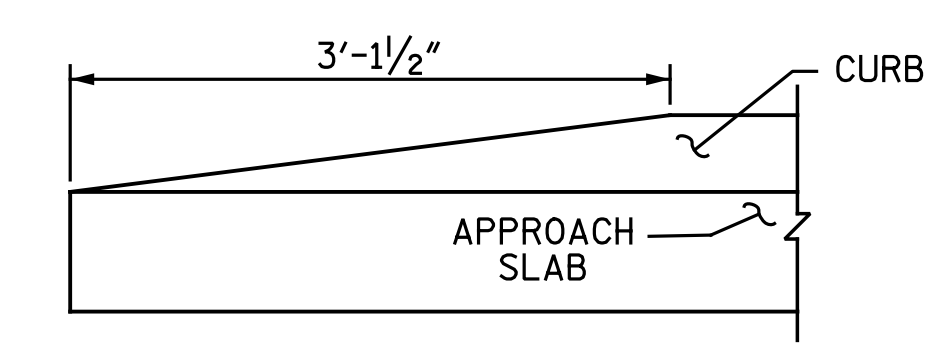

END OF CURB WITHOUT SHOULDER BERM GUTTER

NOTES

AT THE CONTRACTOR'S OPTION, THE APPROACH SLAB MAY BE CAST MONOLITHICALLY WITH THE INTEGRAL END BENT DIAPHRAGM AND THE END SECTION OF BRIDGE DECK. IF CAST WITH THE INTEGRAL DIAPHRAGM, THE LAYERS OF ROOFING FELT SHALL BE OMITTED. IF CAST SEPARATE FROM THE INTEGRAL DIAPHRAGM, APPROACH SLAB SHALL NOT BE CONSTRUCTED PRIOR TO COMPLETION OF THE BRIDGE DECK.

THE JOINT OPENING AT THE APPROACH SLAB/DECK INTERFACE SHALL BE SAWED NO MORE THAN 12 HOURS AFTER THE APPROACH SLAB IS CAST. THE JOINT SHALL BE CLEANED OF ALL DEBRIS BEFORE THE SEALANT IS APPLIED. THE JOINT SEALER MATERIAL SHALL CONFORM TO THE REQUIREMENTS OF SECTION 1028-3 OF THE STANDARD SPECIFICATIONS.

THE JOINT IN THE DECK SHALL BE SAWED PRIOR TO THE CASTING OF THE SIDEWALK.

FOR BRIDGE APPROACH FILL INCLUDING GEOTEXTILE, 4" Ø DRAINAGE PIPE, AND #78M STONE BACKFILL, SEE ROADWAY PLANS.

GEOTEXTILE SHALL BE TYPE 1 IN ACCORDANCE WITH THE STANDARD SPECIFICATIONS SECTION 1056.

#78M STONE BACKFILL (CLASS V SELECT MATERIAL) SHALL BE IN ACCORDANCE WITH STANDARD SPECIFICATIONS SECTION 1016.

#78M STONE BACKFILL IS TO BE CONTINUOUS ALONG FILL FACE OF BACKWALL FROM OUTSIDE EDGE TO OUTSIDE EDGE OF APPROACH SLAB.

FOR THE 4" Ø DRAINAGE PIPE OUTLET(S), SEE ROADWAY STANDARD DRAWINGS.

AREA BETWEEN THE WINGWALL AND APPROACH SLAB SHALL BE GRADED TO DRAIN THE WATER AWAY FROM THE FILL FACE OF THE BRIDGE AND SHALL BE PAVED. SEE ROADWAY PLANS.

BILL OF MATERIAL

APPROACH SLAB AT END BENT 1					
BAR	NO.	SIZE	TYPE	LENGTH	WEIGHT
A1E	52	#4	STR.	19' - 3"	669
A2	52	#4	STR.	19' - 1"	663
B1E	68	#5	STR.	24' - 2"	1,714
B2	68	#6	STR.	24' - 8"	2,519
B3E	4	#4	STR.	24' - 8"	66
G1E	25	#4	STR.	5' - 3"	88
U1E	8	#4	1	3' - 0"	16

EPOXY COATED REINFORCING STEEL	LBS.	2,553
REINFORCING STEEL	LBS.	3,182
CLASS AA CONCRETE	C.Y.	40.0

BILL OF MATERIAL

APPROACH SLAB AT END BENT 2					
BAR	NO.	SIZE	TYPE	LENGTH	WEIGHT
A1E	52	#4	STR.	19' - 3"	669
A2	52	#4	STR.	19' - 1"	663
B1E	68	#5	STR.	24' - 2"	1,714
B2	68	#6	STR.	24' - 8"	2,519
B3E	4	#4	STR.	24' - 8"	66
G1E	25	#4	STR.	5' - 3"	88
U1E	8	#4	1	3' - 0"	16

EPOXY COATED REINFORCING STEEL	LBS.	2,553
REINFORCING STEEL	LBS.	3,182
CLASS AA CONCRETE	C.Y.	40.0

BAR TYPE

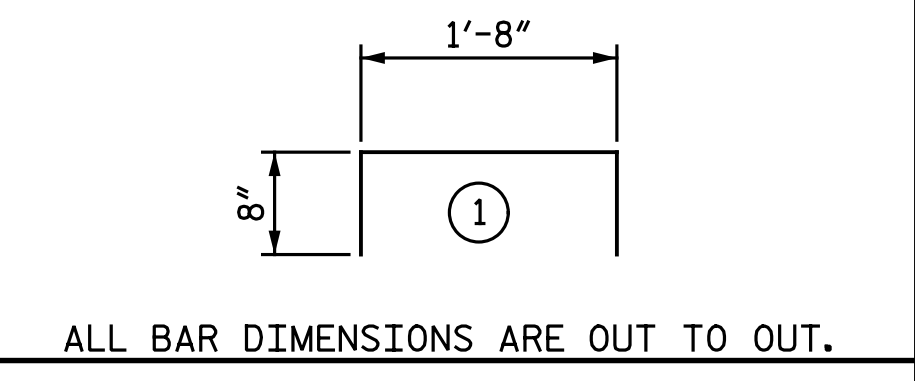

ALL BAR DIMENSIONS ARE OUT TO OUT.

SPlice LENGTHS		
BAR SIZE	EPOXY COATED	UNCOATED
#4	2'-0"	1'-9"
#5	2'-6"	2'-2"
#6	3'-10"	2'-7"

PROJECT NO. U-3330
 NASH COUNTY
 STATION: 18+22.61 -Y1-

DRAWN BY: N. B. SPEAKS DATE: 6-30-16
 CHECKED BY: A. H. SHARPE DATE: 9-2-16

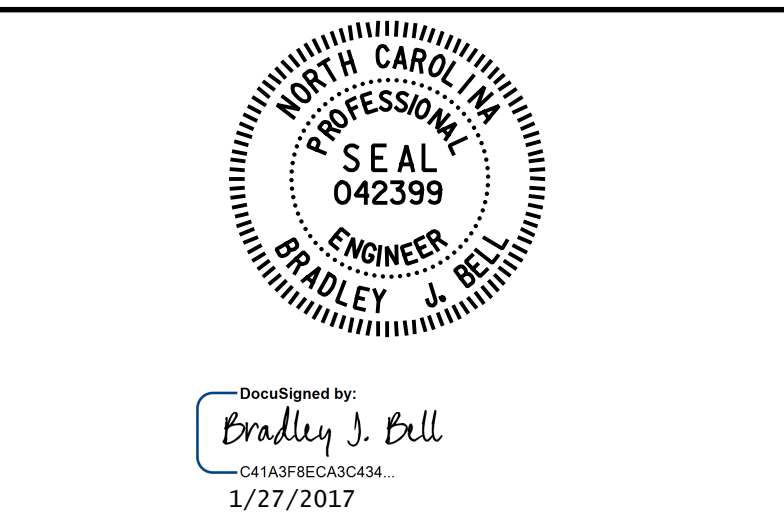

Michael Baker Engineering
 8000 Regency Parkway, Suite 600
 Cary, North Carolina 27518
 NC License No.: F-1084

STATE OF NORTH CAROLINA
 DEPARTMENT OF TRANSPORTATION
 RALEIGH
 BRIDGE APPROACH SLAB
 FOR INTEGRAL ABUTMENT
 LEFT LANES

REVISIONS					SHEET NO. SI-37
NO.	BY:	DATE:	NO.	BY:	
1			3		TOTAL SHEETS
2			4		38

STD. NO. BAS5