

PHASING DIAGRAM

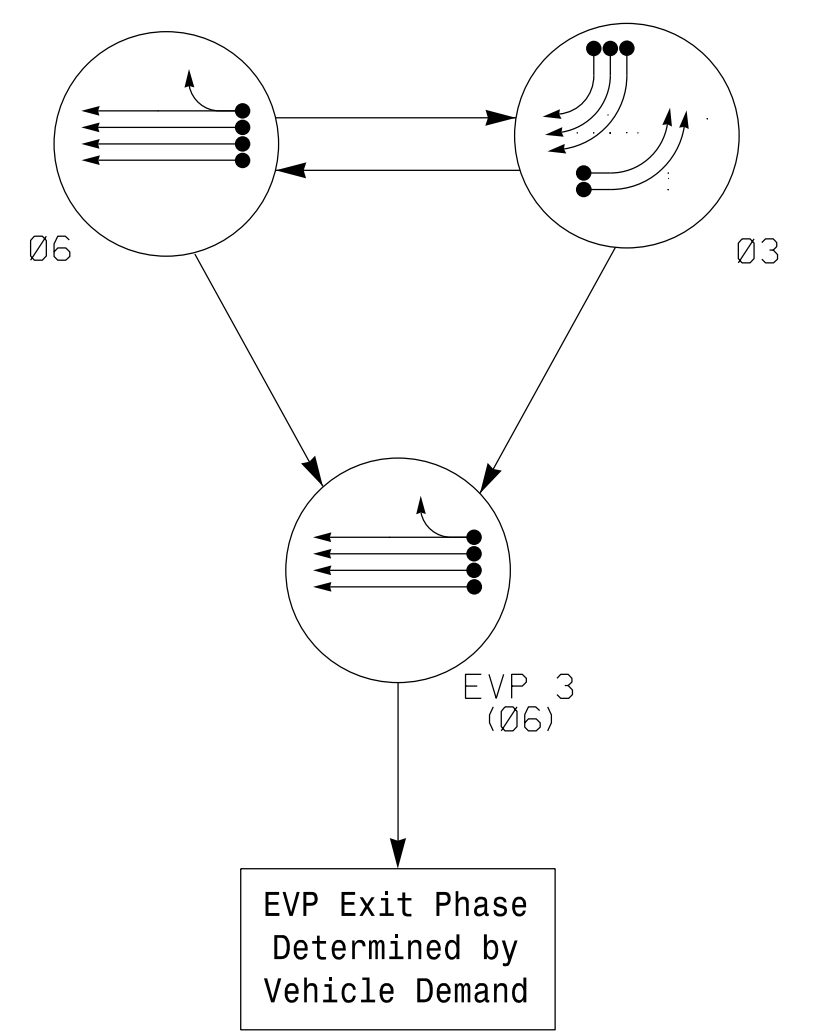
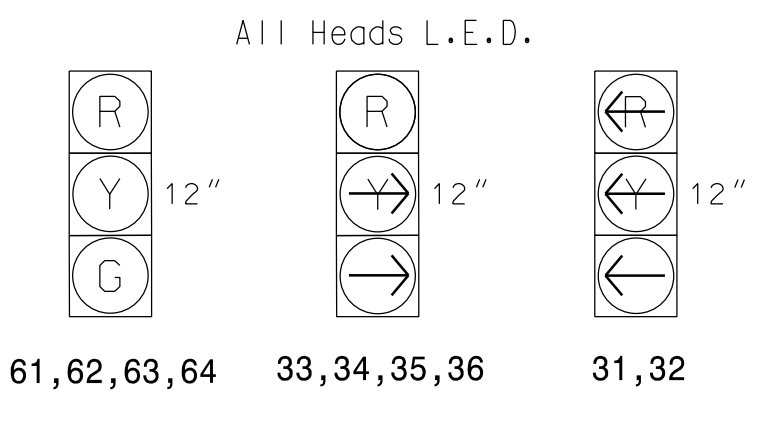

TABLE OF OPERATION table with columns for SIGNAL FACE, PHASE, and various signal settings.

SIGNAL FACE I.D.



OASIS 2070 LOOP & DETECTOR INSTALLATION CHART table with columns for LOOP, SIZE, DISTANCE FROM STOPBAR, TURNS, NEW LOOP, PHASE, CALLING, EXTENSION, FULL TIME DELAY, STRETCH TIME, DELAY TIME, SYSTEM LOOP, and NEW CARD.

2 Phase W/ EV Preempt Fully Actuated Rocky Mount Signal System

NOTES

- 1. Refer to "Roadway Standard Drawings NCDOT" dated January 2012... 2. Do not program signal for late night flashing operation... 3. Set all detector units to presence mode... 4. This intersection features an optical preemption system... 5. Relocate EVP 3 detector onto new span... 6. Maximum times shown in timing charts are for free-run operation only.

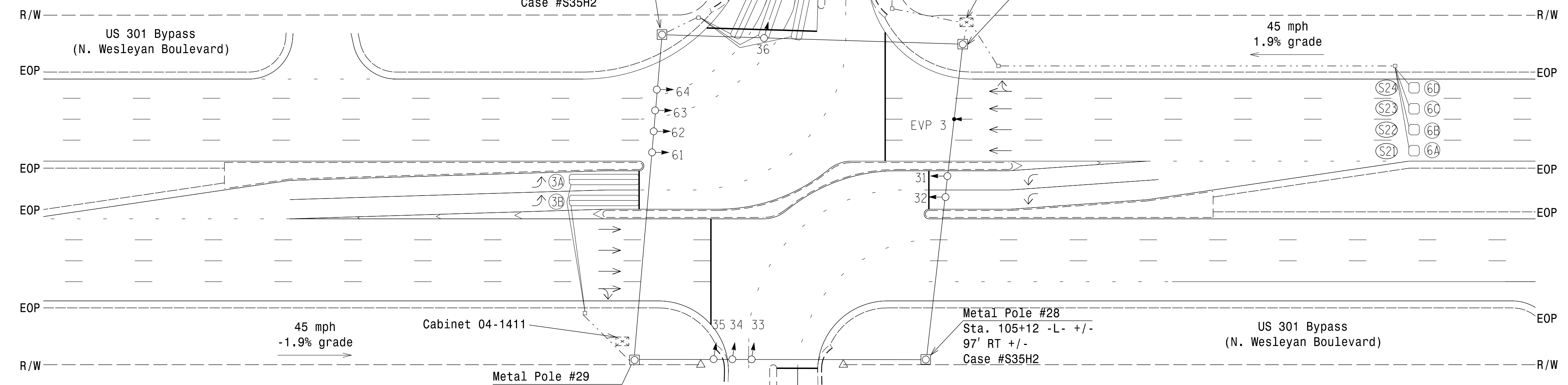
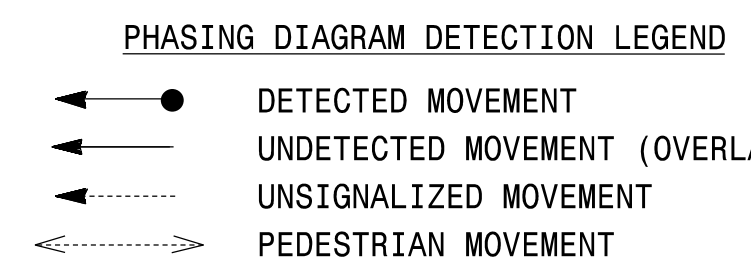

OASIS 2070E TIMING CHART table with columns for FEATURE, PHASE 3, and PHASE 6.

OASIS 2070 EV PREEMPT table with columns for FUNCTION and PRE 3.

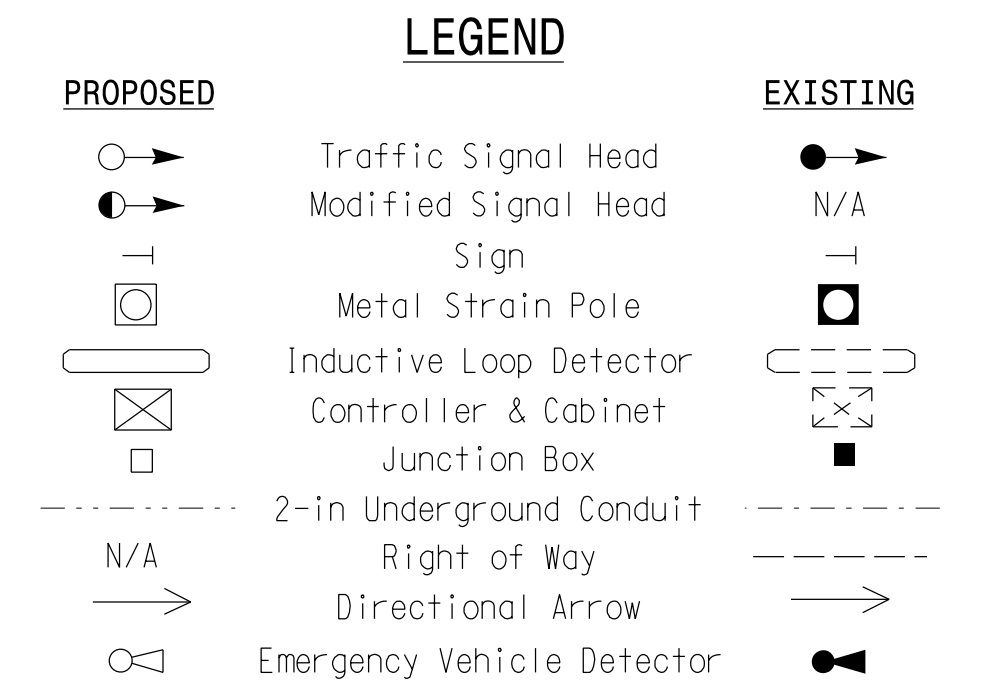

* These values may be field adjusted. Do not adjust Min Green and Extension times for phases 2 and 6 lower than what is shown.

ATKINS 1616 EAST MILLBROOK ROAD, SUITE 160 RALEIGH, NORTH CAROLINA 27609 (919) 876-8888 NCBEES #F-0326

Signal Upgrade - Final Design DOCUMENT NOT CONSIDERED FINAL UNLESS ALL SIGNATURES COMPLETED. Includes project details, dates, and professional seals.

30-JAN-2017 18:10:06 D:\Projects\2017\10002135_U-3330_Signals\402_Signals\04-0802.dgn