

CULVERT SECTION NORMAL TO ROADWAY

NOTE: WING WALLS NOT SHOWN FOR CLARITY
SCALE: NTS

** A146-A166 ARE PHASE 3 BOTTOM OF FLOOR SLAB BARS.
A234-A248 ARE PHASE 3 TOP OF FLOOR SLAB BARS.
A319-A333 ARE PHASE 2 BOTTOM OF ROOF SLAB BARS.
A430-A456 ARE PHASE 2 TOP OF ROOF SLAB BARS.
THESE BARS ARE NOT SHOWN FOR CLARITY.

NOTES:

- BARS ON LEFT END ON PHASE 2 SHOULD EXTEND INTO PHASE 3 IN THE FOLLOWING LENGTHS:
A125-A145: 2'-11"
A219-A233: 2'-4"
A319-A333: 3'-11"
A430-A456: 2'-4"
- PHASE 2 "C" BARS RUN 1'-11" INTO PHASE 3.
- (3) A100, A200, A300 AND A400 BARS EXTEND BEYOND CONSTRUCTION JOINT.

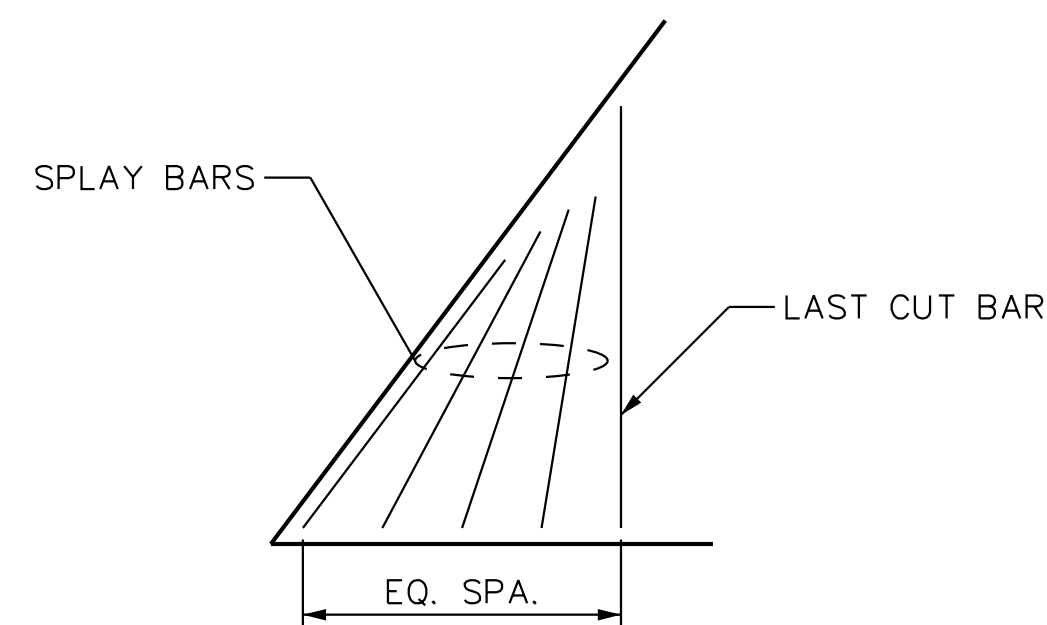

SPLAY BAR DETAIL

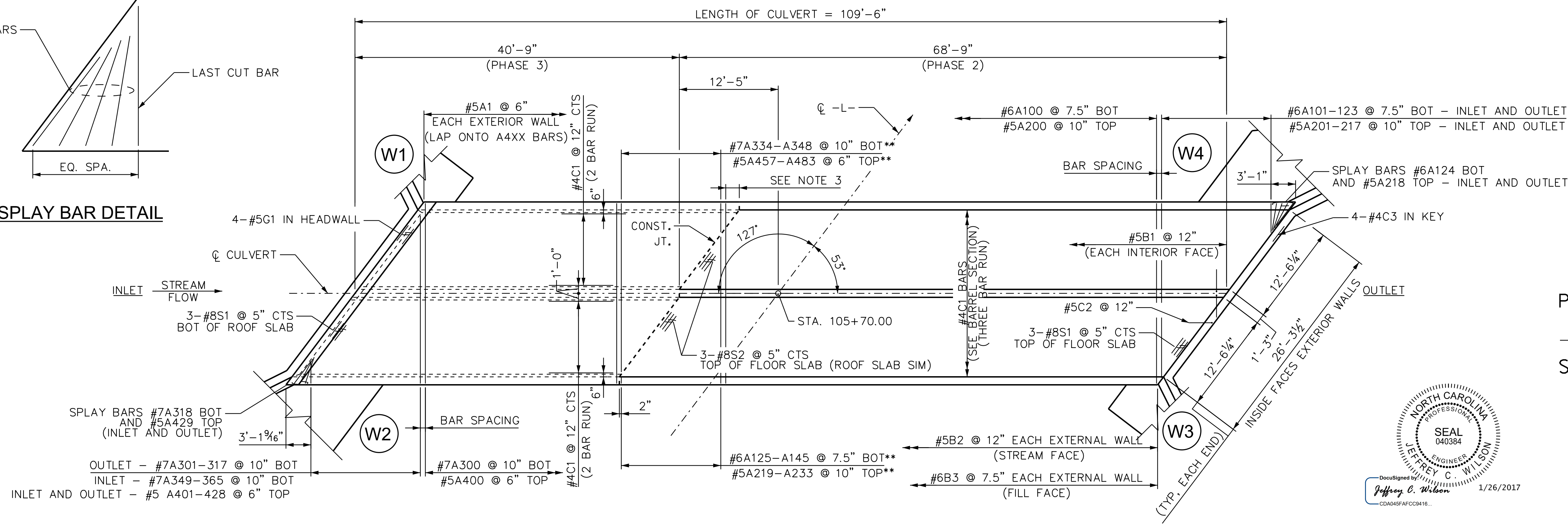

PART PLAN - ROOF SLAB

SCALE: 1/8" = 1'-0"

PART PLAN - FLOOR SLAB

SCALE: 1/8" = 1'-0"

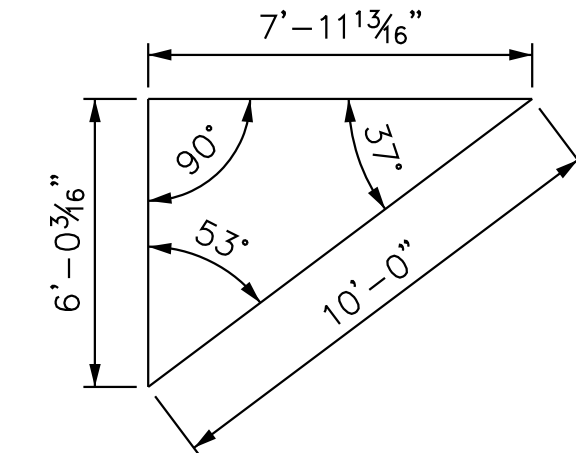

SKEW TRIANGLE

PROJECT NO. EB-4707B
DURHAM COUNTY
STATION: 105+70.00 -L-

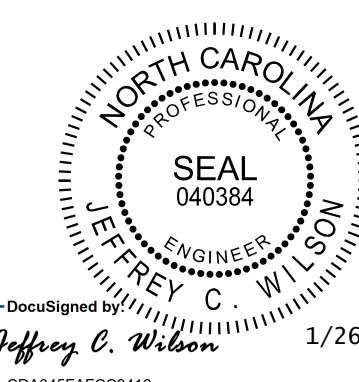

Kimley»Horn

421 Fayetteville Street, Suite 600
Raleigh, NC 27601-1772
Phone (919) 677-2000
NC LICENSE # F-0102

STATE OF NORTH CAROLINA
DEPARTMENT OF TRANSPORTATION
RALEIGH
**DOUBLE 10' x 7'
CONCRETE BOX CULVERT
53° SKEW**
CULVERT SECTION AND PLAN

REVISIONS					
NO.	BY	DATE	NO.	BY	DATE
1			3		
2			4		

DRAWN BY: JIK DATE: 1/17
CHECKED BY: DJW DATE: 1/17

This document, together with the concepts and designs presented herein, is an instrument of service, is intended only for the specific purpose and client for which it was prepared. Reuse of and Engineer reliance of this document without written authorization and approval by Kimley-Horn and Associates, Inc. shall be without liability to Kimley-Horn and Associates, Inc.
Copyright Kimley-Horn and Associates, Inc., 2017

SHEET NO. **C3**
TOTAL SHEETS **24**