

PROJECT REFERENCE NO. R-2707C	SHEET NO. PMP-1
APPROVED: <u>Andrew D. Klinksiek</u> <small>DocuSigned by: Andrew D. Klinksiek E3D78FB469E44B</small>	
DATE: 2/17/2017	
SEAL 	
DOCUMENT NOT CONSIDERED FINAL UNLESS ALL SIGNATURES COMPLETED	

**STATE OF NORTH CAROLINA  
DEPARTMENT OF TRANSPORTATION**

**PAVEMENT MARKING PLAN  
CLEVELAND COUNTY**

**LOCATION: US 74 SHELBY BYPASS FROM EAST OF NC 226  
TO EAST OF NC 150**

**CONTRACT: C203905 T.I.P.: R-2707C**

**INDEX**

<u>SHEET NO.</u>	<u>DESCRIPTION</u>
PMP-1	PAVEMENT MARKING PLAN TITLE, LIST OF STANDARD DRAWINGS, GENERAL NOTES AND INDEX OF SHEETS
PMP-1A	FINAL PAVEMENT MARKING SCHEDULE AND LEGEND
PMP-1B & 1C	REVISED PAVEMENT MARKING ROADWAY STANDARD DRAWINGS
PMP-2 THRU PMP-14	PAVEMENT MARKING DETAILS

**GENERAL NOTES**

- THE FOLLOWING GENERAL NOTES APPLY AT ALL TIMES FOR THE DURATION OF THE CONSTRUCTION PROJECT, EXCEPT WHEN OTHERWISE NOTED IN THE PLAN, OR DIRECTED BY THE ENGINEER.
- A) INSTALL PAVEMENT MARKINGS AND PAVEMENT MARKERS ON THE FINAL SURFACE AS FOLLOWS:
- | <u>ROAD NAME</u>      | <u>MARKING</u>                | <u>MARKER</u> |
|-----------------------|-------------------------------|---------------|
| -Y2- (SR 1850)        | THERMOPLASTIC                 | SNOWPLOWABLE  |
| -Y3- (SR 1005)        | THERMOPLASTIC                 | SNOWPLOWABLE  |
| -Y4-REV (SR 1827)     | THERMOPLASTIC                 | SNOWPLOWABLE  |
| -Y6A- (SR 1843)       | THERMOPLASTIC                 | SNOWPLOWABLE  |
| -Y9- (NC 18)          | THERMOPLASTIC                 | SNOWPLOWABLE  |
| -Y8-REV               | THERMOPLASTIC                 | SNOWPLOWABLE  |
| -Y8A- (SR 1927)       | THERMOPLASTIC                 | SNOWPLOWABLE  |
| -Y11-REV2 (NC 180)    | THERMOPLASTIC                 | SNOWPLOWABLE  |
| -Y14- (NC 150)        | THERMOPLASTIC                 | SNOWPLOWABLE  |
| -Y16-REV (SR 2155)    | THERMOPLASTIC                 | SNOWPLOWABLE  |
| -SR2-                 | THERMOPLASTIC                 | SNOWPLOWABLE  |
| -Y5-, -Y10- AND -Y18- | NONE                          | NONE          |
| ALL BRIDGE DECKS      | COLD APPLIED PLASTIC, TYPE II | RAISED        |
- B) TIE PROPOSED PAVEMENT MARKING LINES TO EXISTING PAVEMENT MARKING LINES.
- C) REMOVE/REPLACE ANY CONFLICTING/DAMAGED PAVEMENT MARKINGS AND MARKERS.
- D) PASSING ZONES WILL BE DETERMINED IN THE FIELD AND MUST BE APPROVED BY THE ENGINEER.
- E) STOP BAR LOCATION AT NON-SIGNALIZED INTERSECTIONS MAY BE ADJUSTED AS DIRECTED BY THE ENGINEER.
- F) REMOVE ALL RESIDUE AND SURFACE LAITANCE BY ACCEPTABLE METHODS ON CONCRETE BRIDGE DECKS PRIOR TO PLACING COLD APPLIED PLASTIC PAVEMENT MARKING MATERIAL.
- G) UNLESS OTHERWISE SPECIFIED, HEATED-IN-PLACE THERMOPLASTIC MAY BE USED IN LIEU OF EXTRUDED THERMOPLASTIC FOR STOP BARS, SYMBOLS, CHARACTERS AND DIAGONALS. IF HEATED-IN-PLACE IS USED, IT SHALL BE PAID FOR USING THE EXTRUDED THERMOPLASTIC PAY ITEM.
- H) TYPE III COLD APPLIED PLASTIC MAY BE USED IN LIEU OF TYPE II COLD APPLIED PLASTIC. IF TYPE III COLD APPLIED PLASTIC IS USED, IT SHALL BE PAID FOR USING THE TYPE II COLD APPLIED PLASTIC PAY ITEM.

**ROADWAY STANDARD DRAWING**

THE FOLLOWING ROADWAY STANDARDS AS APPEAR IN "ROADWAY STANDARD DRAWINGS" - PROJECT SERVICES UNIT - N.C. DEPARTMENT OF TRANSPORTATION - RALEIGH, N.C., DATED JANUARY 2012 ARE APPLICABLE TO THIS PROJECT AND BY REFERENCE HEREBY ARE CONSIDERED A PART OF THESE PLANS:

<u>STD. NO.</u>	<u>TITLE</u>
1205.01	PAVEMENT MARKINGS - LINE TYPES AND OFFSETS
1205.02	PAVEMENT MARKINGS - TWO-LANE AND MULTILANE ROADWAYS
1205.04	PAVEMENT MARKINGS - INTERSECTIONS
1205.05	PAVEMENT MARKINGS - TURN LANES
1205.06	PAVEMENT MARKINGS - LANE DROPS
1205.08	PAVEMENT MARKINGS - SYMBOLS AND WORD MESSAGES
1205.09	PAVEMENT MARKINGS - PAINTED ISLANDS
1205.12	PAVEMENT MARKINGS - BRIDGES
1250.01	RAISED PAVEMENT MARKERS - INSTALLATION SPACING
1251.01	RAISED PAVEMENT MARKERS - PERMANENT AND TEMPORARY
1253.01	RAISED PAVEMENT MARKERS - SNOWPLOWABLE
1261.01	GUARDRAIL AND BARRIER DELINEATORS - INSTALLATION SPACING
1261.02	GUARDRAIL AND BARRIER DELINEATORS - TYPES AND MOUNTING
1262.01	GUARDRAIL END DELINEATION
1264.01	OBJECT MARKERS - TYPES
1264.02	OBJECT MARKERS - INSTALLATION

PLAN REVIEWED BY: N.C.D.O.T. SIGNING AND DELINEATION UNIT

K. L. Jordan SIGNING & DELINEATION REGIONAL ENGINEER

Bobby Navarrete SIGNING & DELINEATION PROJECT DESIGN ENGINEER/TECHNICIAN

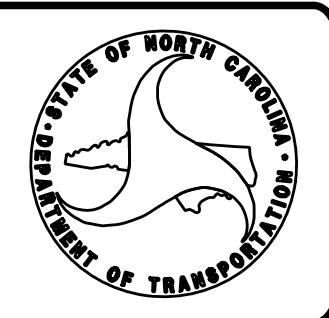

PLAN PREPARED BY: HNTB NORTH CAROLINA, P.C.

A. Klinksiek, PE, PTOE PROJECT ENGINEER

J. Phillips PROJECT DESIGNER

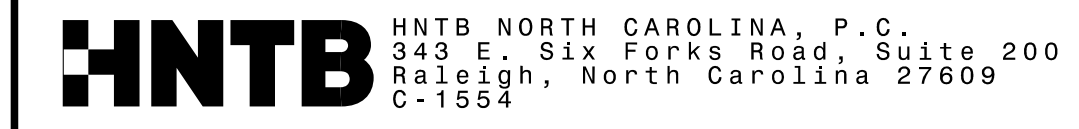

TIP NO. R - 2707C	SHEET NO. PMP - 1A
APPROVED: <i>Andrew D. Klincksiek</i> E3D78FB4596E44B...	
DATE: 2/17/2017	
	
DOCUMENT NOT CONSIDERED FINAL UNLESS ALL SIGNATURES COMPLETED	

# FINAL PAVEMENT MARKING SCHEDULE

MATERIAL	SYMBOL	DESCRIPTION
<b>PAVEMENT MARKING</b>		
<u>COLD APPLIED PLASTIC, TYPE II (4")</u>		
	CA	WHITE EDGELINE
	CB	YELLOW EDGELINE
	CC	10' WHITE SKIP
	CI	YELLOW DOUBLE CENTERLINE
<u>COLD APPLIED PLASTIC, TYPE II (8")</u>		
	CP	YELLOW DIAGONAL
<u>THERMOPLASTIC (4") (90 MIL)</u>		
	TA	WHITE EDGELINE
	TB	YELLOW EDGELINE
<u>THERMOPLASTIC (4") (120 MIL)</u>		
	T8	2FT-6FT WHITE MINI-SKIP
	TC	10FT WHITE SKIP
	TD	3FT-9FT WHITE MINI-SKIP
	TE	WHITE SOLID LANE LINE
	TI	YELLOW DOUBLE CENTER
<u>THERMOPLASTIC (8") (90 MIL)</u>		
	TN	WHITE GORE
	TP	YELLOW DIAGONAL
<u>THERMOPLASTIC (8") (120 MIL)</u>		
	T13	3 FT - 9FT /SP WHITE MINISKIP
	T17	3 FT - 3FT /SP WHITE MINISKIP
	TR	WHITE SOLID LANE LINE
<u>THERMOPLASTIC (24") (120 MIL)</u>		
	T2	WHITE STOPBAR
<u>THERMOPLASTIC SYMBOL (90 MIL)</u>		
	UA	LEFT TURN ARROW
	UB	RIGHT TURN ARROW
	UC	STRAIGHT ARROW
	UD	COMBO. LEFT/STRAIGHT ARROW
	UE	COMBO. RIGHT/STRAIGHT ARROW
	UN	12" YIELD LINE TRIANGLE
	UU	FISH-HOOK STRAIGHT ARROW
	UW	FISH-HOOK RIGHT/STRAIGHT ARROW
	UZ	FISH-HOOK W/CIRCLE STRAIGHT ARROW
	WA	FISH-HOOK W/CIRLCE LEFT ARROW
	WB	FISH-HOOK W/CIRCLE LEFT/STRAIGHT ARROW
	WC	FISH-HOOK W/CIRCLE LEFT/RIGHT/STRAIGHT ARROW
<u>THERMOPLASTIC CHARACTERS (120 MIL)</u>		
	UI	ALPHANUMERIC CHAR.

## LEGEND

### GENERAL

- DIRECTION OF TRAFFIC FLOW
- NORTH ARROW
- ..... PROPOSED PVMT.    - - - - - EXIST. PVMT.

### PAVEMENT MARKINGS

#### PAVEMENT MARKING SYMBOLS

- UA
- UB
- UC
- UD
- UE
- UI ONLY
- UN
- UU
- UW
- UZ
- WA
- WB
- WC

\$\$\$SYTIME\$\$\$\$  
 \$\$\$DCON\$\$\$\$  
 \$\$\$USERNAME\$\$\$\$



## FINAL PAVEMENT MARKING SCHEDULE AND LEGEND

TIP NO.	SHEET NO. PMP-1B
APPROVED: <i>RWJ</i> 3/6/12	
DATE:	
SEAL	
	

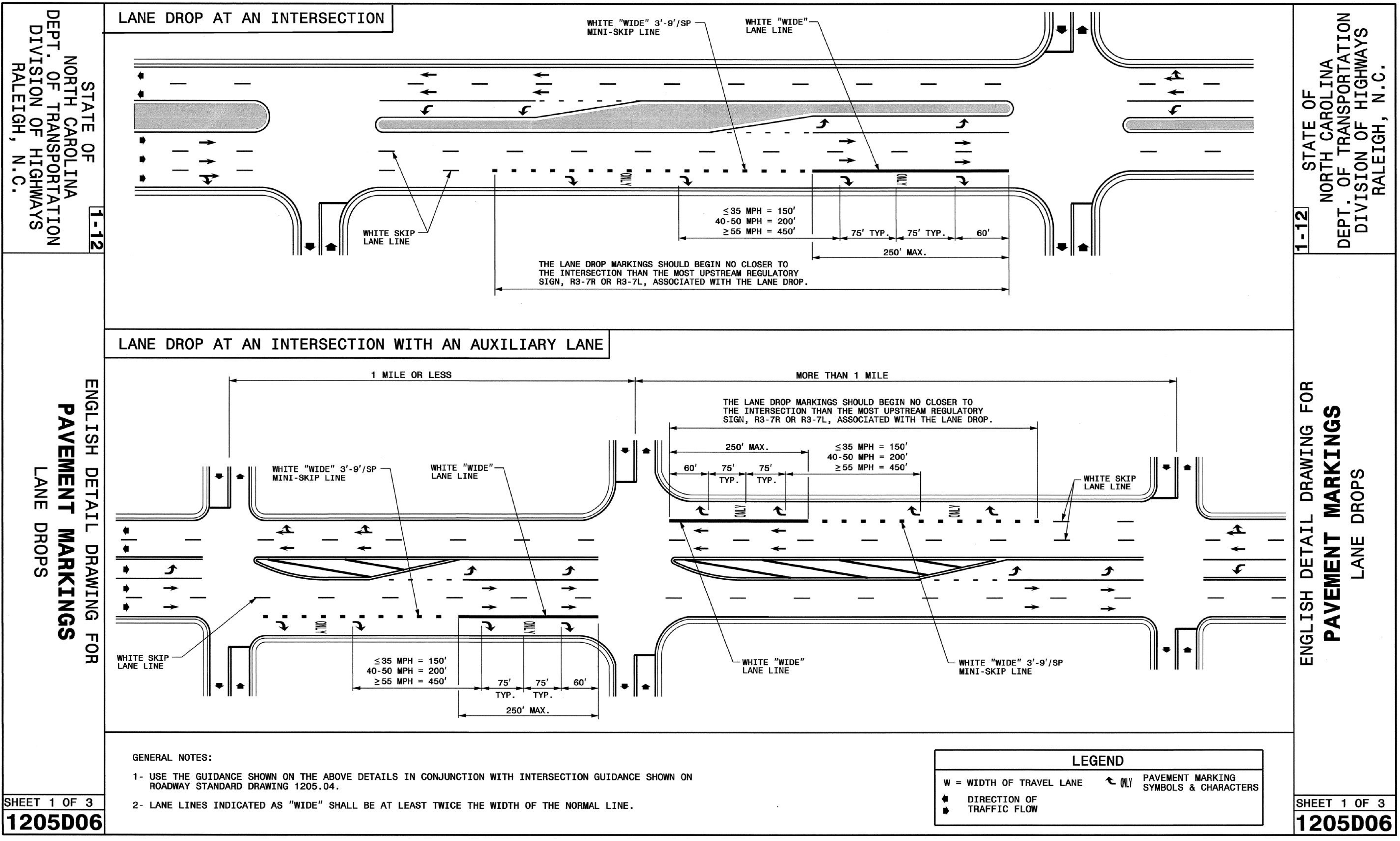

08-MAR-2012 11:09  
 S:\3300\Standard Drawings\Standard Drawings\8-17-11\Revised\1205D06\Revised 9-14-11\_Scaled.dgn  
 Storages AT 12344745  
 \*\*\*\*\*  
 \$\$\$\$SYTIME\$\$\$\$  
 \$\$\$\$DGN\$\$\$\$  
 \$\$\$\$USERNAME\$\$\$\$

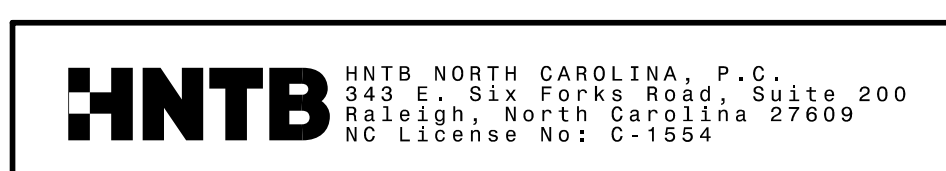

REVISED PAVEMENT MARKING  
ROADWAY STANDARD DRAWING

REVISED PAVEMENT MARKING  
ROADWAY STANDARD DRAWING



TIP NO. R - 2707C	SHEET NO. PMP - 2
APPROVED: <u>Andrew D. Klinck</u> E3078F8459E448	
DATE: 2/17/2017	
SEAL	
	
DOCUMENT NOT CONSIDERED FINAL UNLESS ALL SIGNATURES COMPLETED	

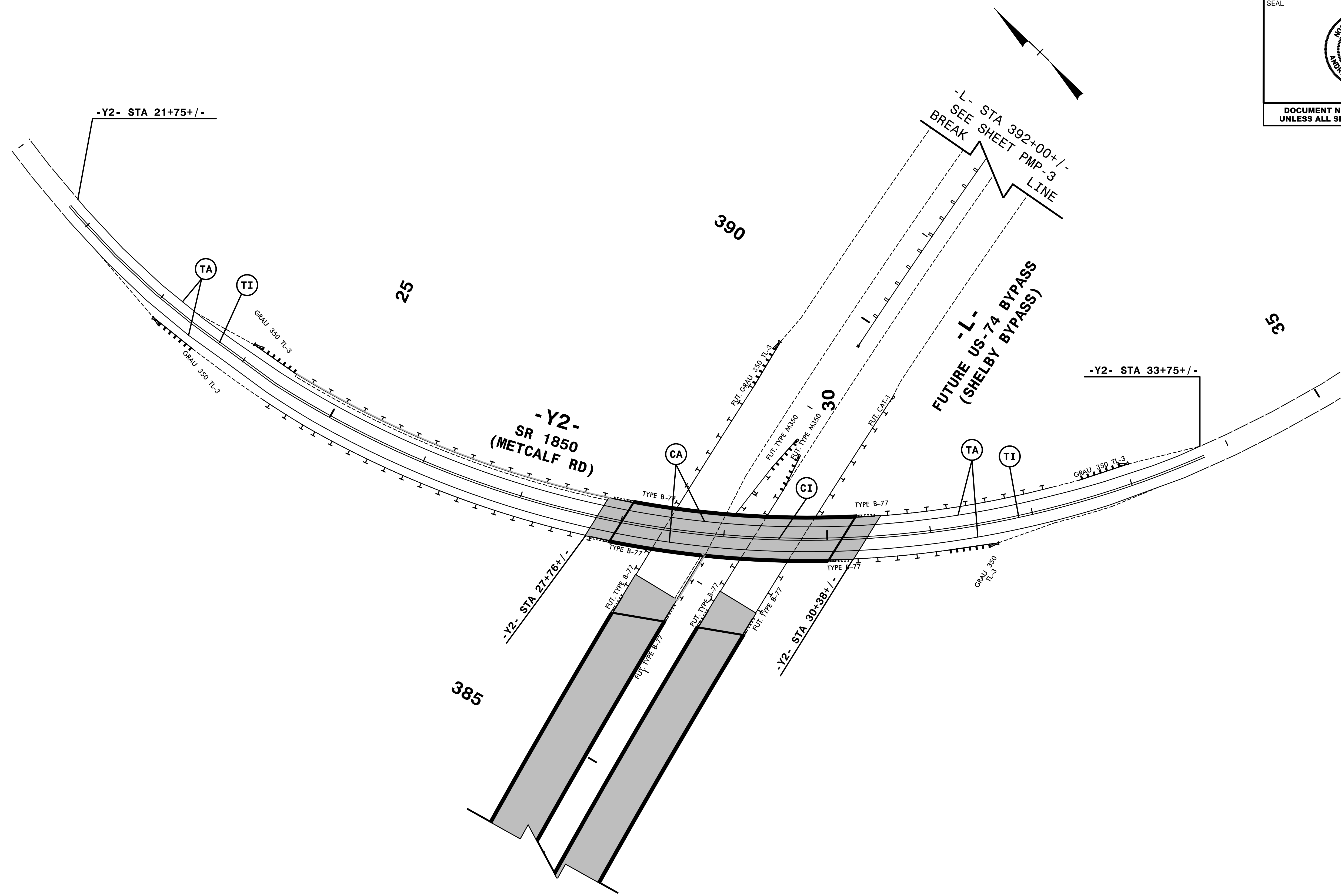

NOTE: ALL LANE WIDTHS ARE 12' UNLESS OTHERWISE SHOWN.

\$\$\$\$\$SYTIME\$\$\$\$\$  
\$\$\$\$\$DUN\$\$\$\$\$  
\$\$\$\$\$USERNAME\$\$\$\$\$

**HNTB** HNTB NORTH CAROLINA, P.C.  
343 E. SLX FORKS ROAD, SUITE 200  
RALEIGH, NORTH CAROLINA 27609  
NC LICENSE NO: C-1554

**PAVEMENT MARKING DETAIL**

TIP NO. R-2707C	SHEET NO. PMP-3
APPROVED: <i>Andrew D. Klincksiek</i> E3078FB4596E44B	
DATE: 2/17/2017	
SEAL	
	
DOCUMENT NOT CONSIDERED FINAL UNLESS ALL SIGNATURES COMPLETED	

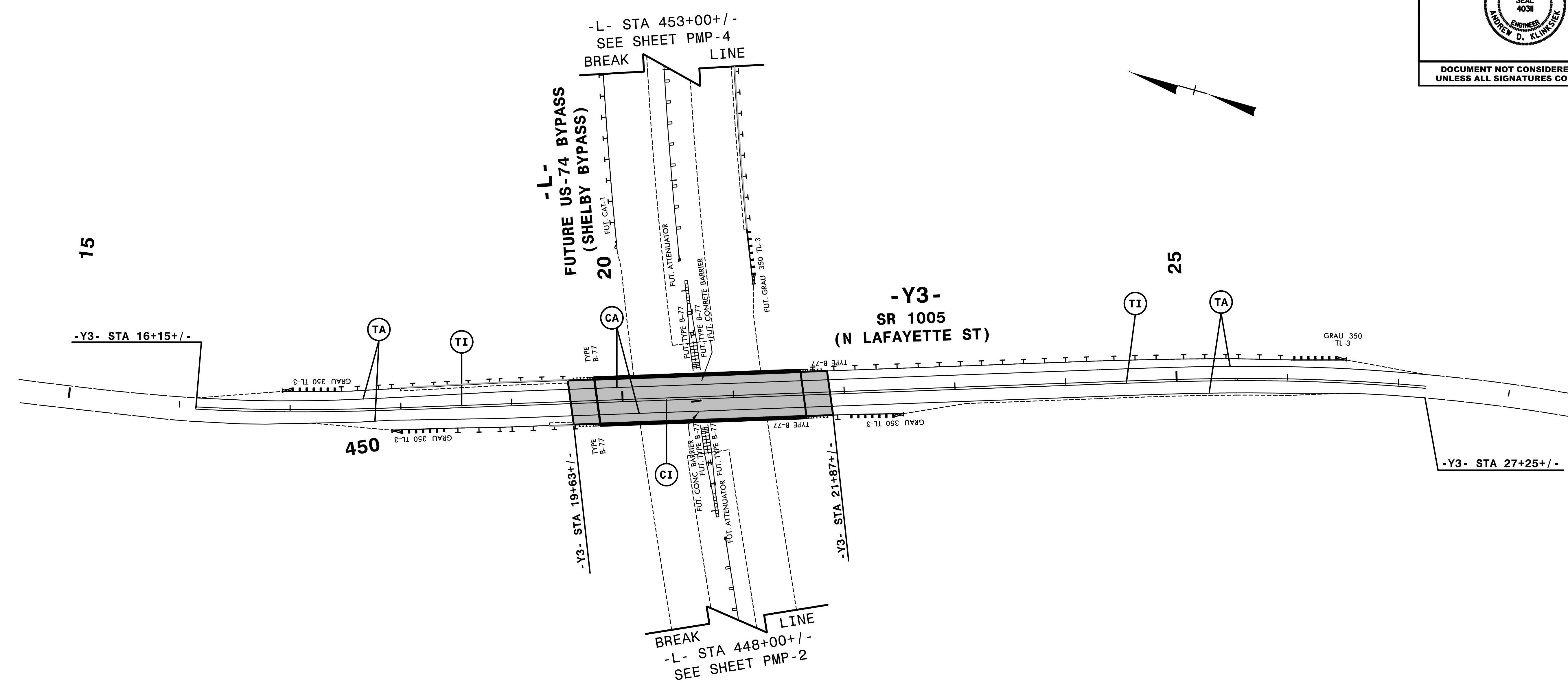

NOTE: ALL LANE WIDTHS ARE 12' UNLESS OTHERWISE SHOWN.

\$\$\$SYTIME\$\$\$  
\$\$\$DCN\$\$\$  
\$\$\$USERNAME\$\$\$

**HNTB** HNTB NORTH CAROLINA, P.C.  
343 E. SIX FORKS ROAD, SUITE 200  
RALEIGH, NORTH CAROLINA 27609  
NC LICENSE NO: C-1554

**PAVEMENT MARKING DETAIL**

TIP NO. R-2707C	SHEET NO. PMP-4
APPROVED: <i>Andrew D. Klincksiek</i> E3078FB459E44B	
DATE: 2/17/2017	
SEAL	
	
DOCUMENT NOT CONSIDERED FINAL UNLESS ALL SIGNATURES COMPLETED	

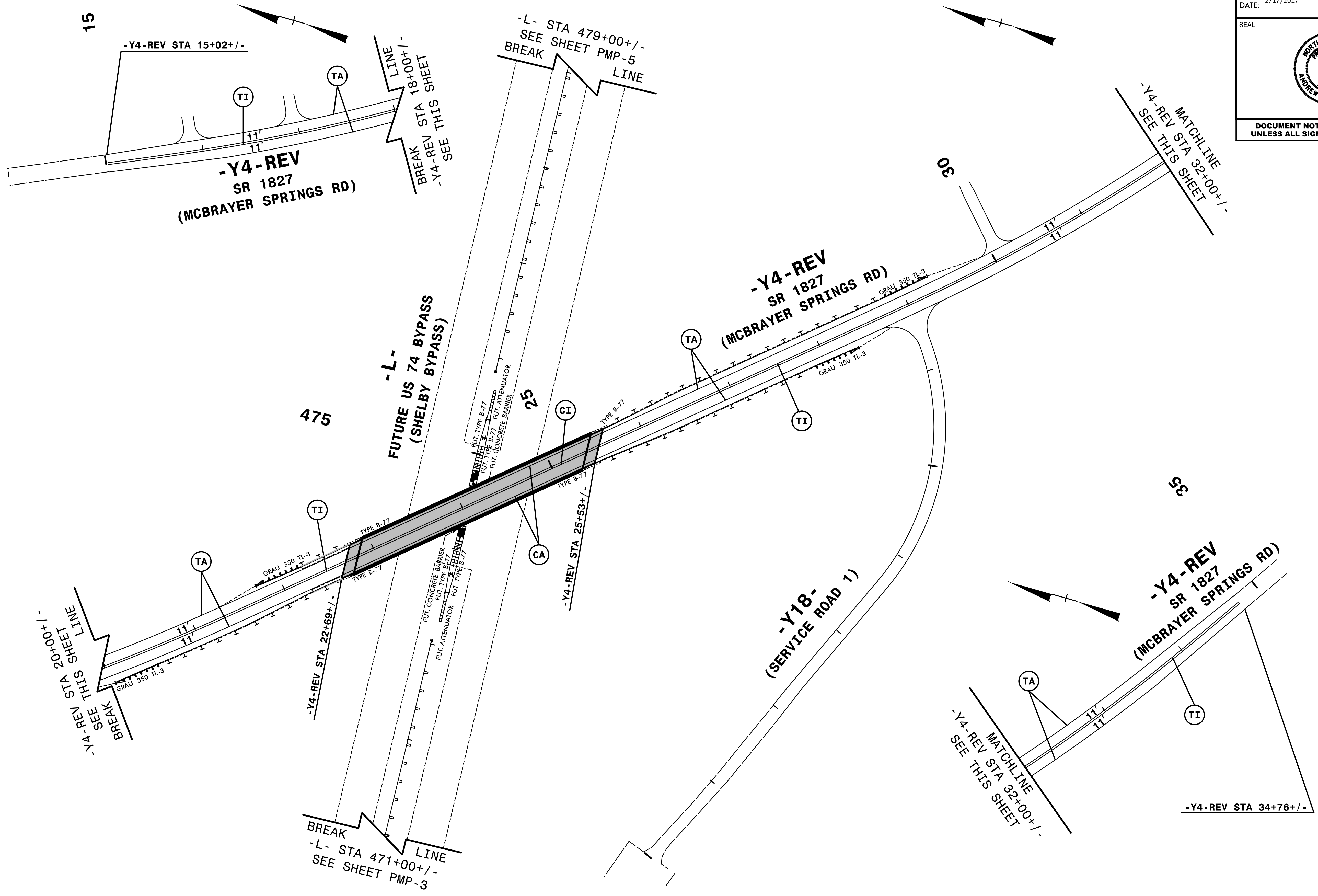

\$\$\$\$\$SYTIME\$\$\$\$\$  
 \$\$\$\$DCN\$\$\$\$\$  
 \$\$\$\$USERNAME\$\$\$\$\$

**HNTB** HNTB NORTH CAROLINA, P.C.  
 343 E. SLX FORKS ROAD, SUITE 200  
 RALEIGH, NORTH CAROLINA 27609  
 NC LICENSE NO: C-1554

**PAVEMENT MARKING DETAIL**

TIP NO. R-2707C	SHEET NO. PMP-5
APPROVED: <i>Andrew D. Klincksiek</i> E3078FB459E44B	
DATE: 2/17/2017	
SEAL	
	
DOCUMENT NOT CONSIDERED FINAL UNLESS ALL SIGNATURES COMPLETED	

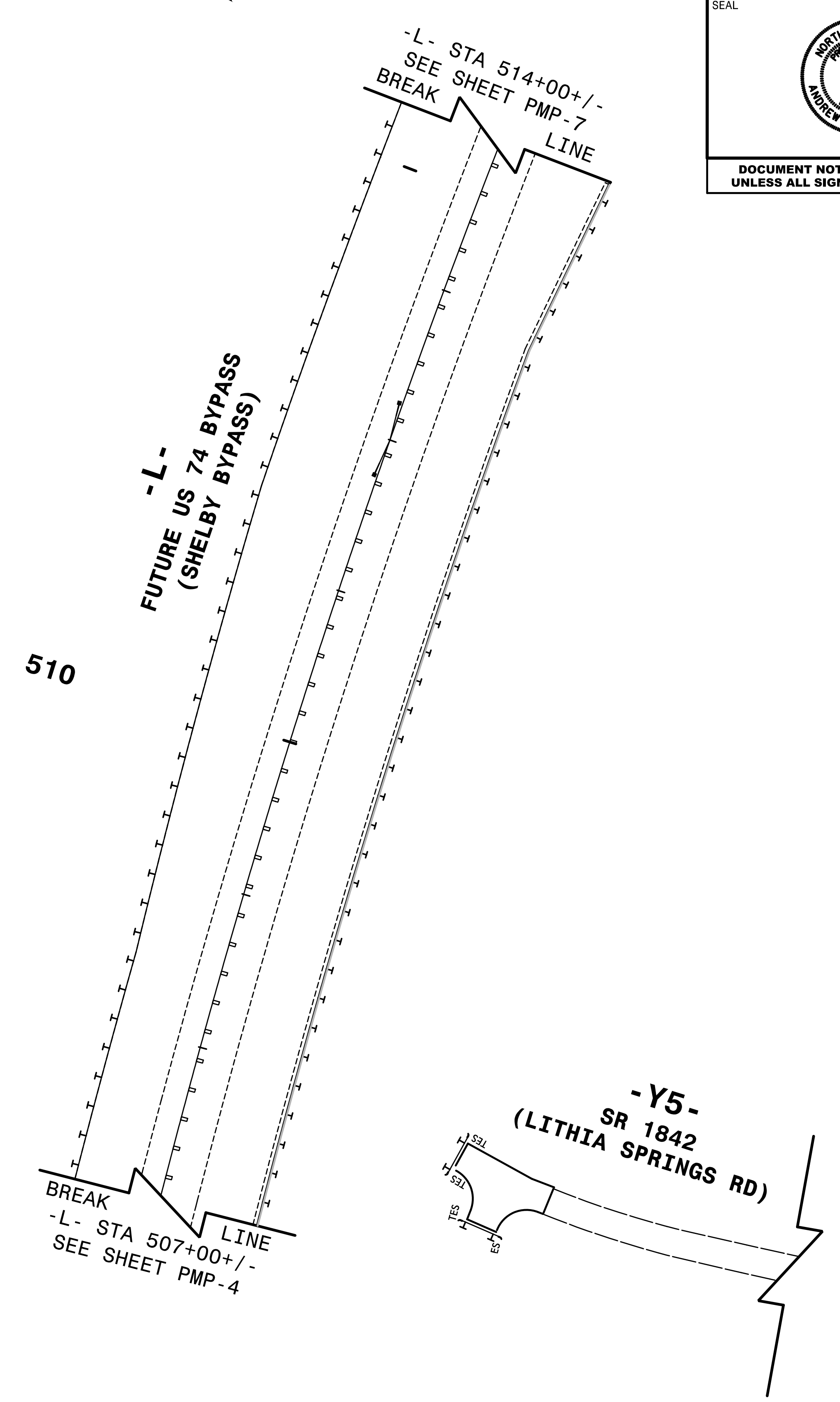
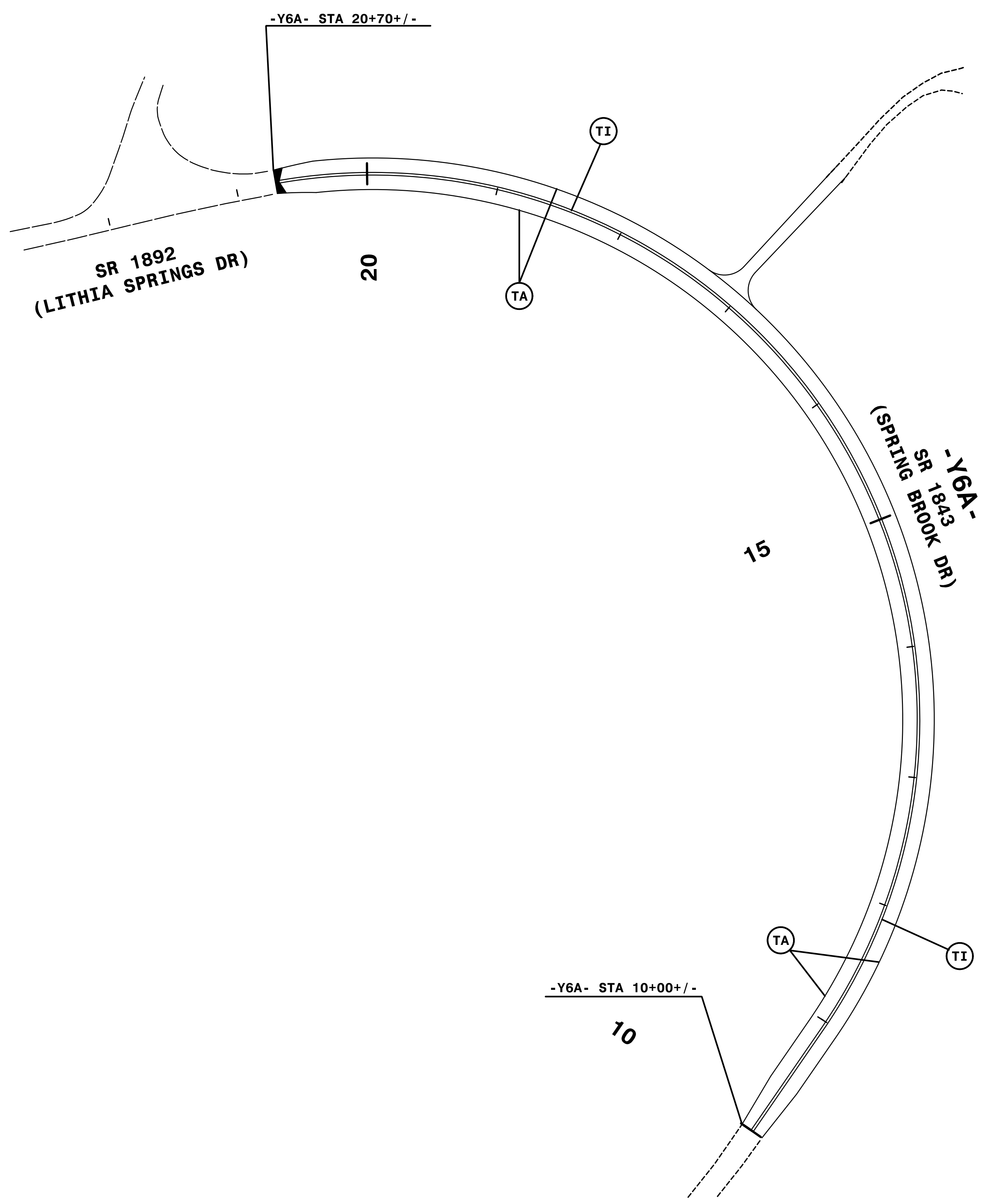

NOTE: ALL LANE WIDTHS ARE 12' UNLESS OTHERWISE SHOWN.

\$\$\$SYTIME\$\$\$  
\$\$\$DUN\$\$\$  
\$\$\$USERNAME\$\$\$

**HNTB** HNTB NORTH CAROLINA, P.C.  
343 E. SLX FORKS ROAD, SUITE 200  
RALEIGH, NORTH CAROLINA 27609  
NC LICENSE NO: C-1554

**PAVEMENT MARKING DETAIL**



TIP NO. R - 2707C	SHEET NO. PMP - 6
APPROVED: <i>Andrew D. Klincksiek</i> E3078FB4598E44B...	
DATE: 2/17/2017	
SEAL	
	
DOCUMENT NOT CONSIDERED FINAL UNLESS ALL SIGNATURES COMPLETED	

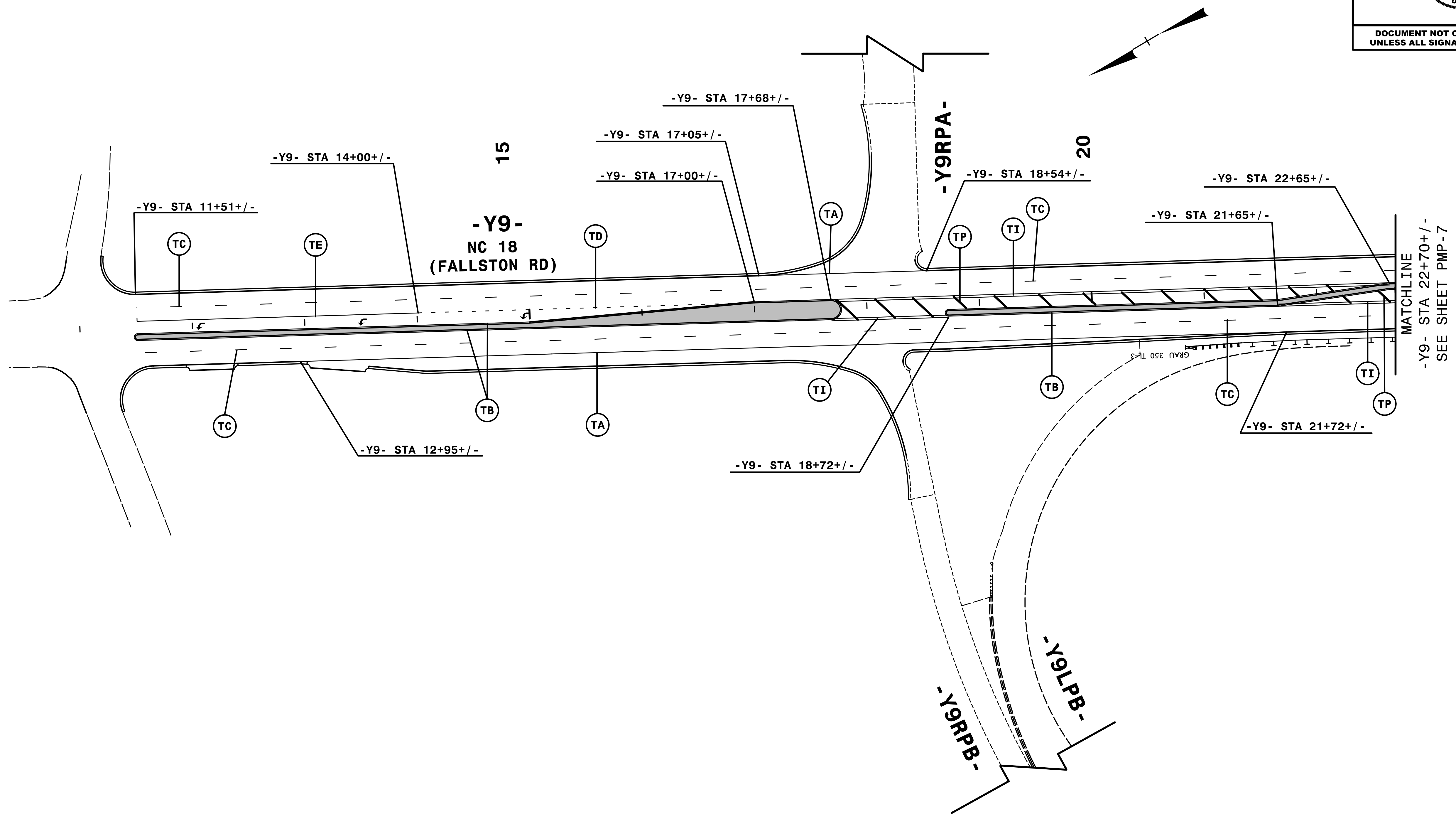

NOTE: ALL LANE WIDTHS ARE 12' UNLESS OTHERWISE SHOWN.

\$\$\$SYTIME\$\$\$  
\$\$\$DCN\$\$\$  
\$\$\$USERNAME\$\$\$

**HNTB** HNTB NORTH CAROLINA, P.C.  
343 E. SLX FORKS ROAD, SUITE 200  
RALEIGH, NORTH CAROLINA 27609  
NC LICENSE NO: C-1554

**PAVEMENT MARKING DETAIL**

TIP NO. R-2707C	SHEET NO. PMP-7
APPROVED: <i>Andrew D. Klincksiek</i> E3078FB4596E44B	
DATE: 2/17/2017	
SEAL	
	
DOCUMENT NOT CONSIDERED FINAL UNLESS ALL SIGNATURES COMPLETED	

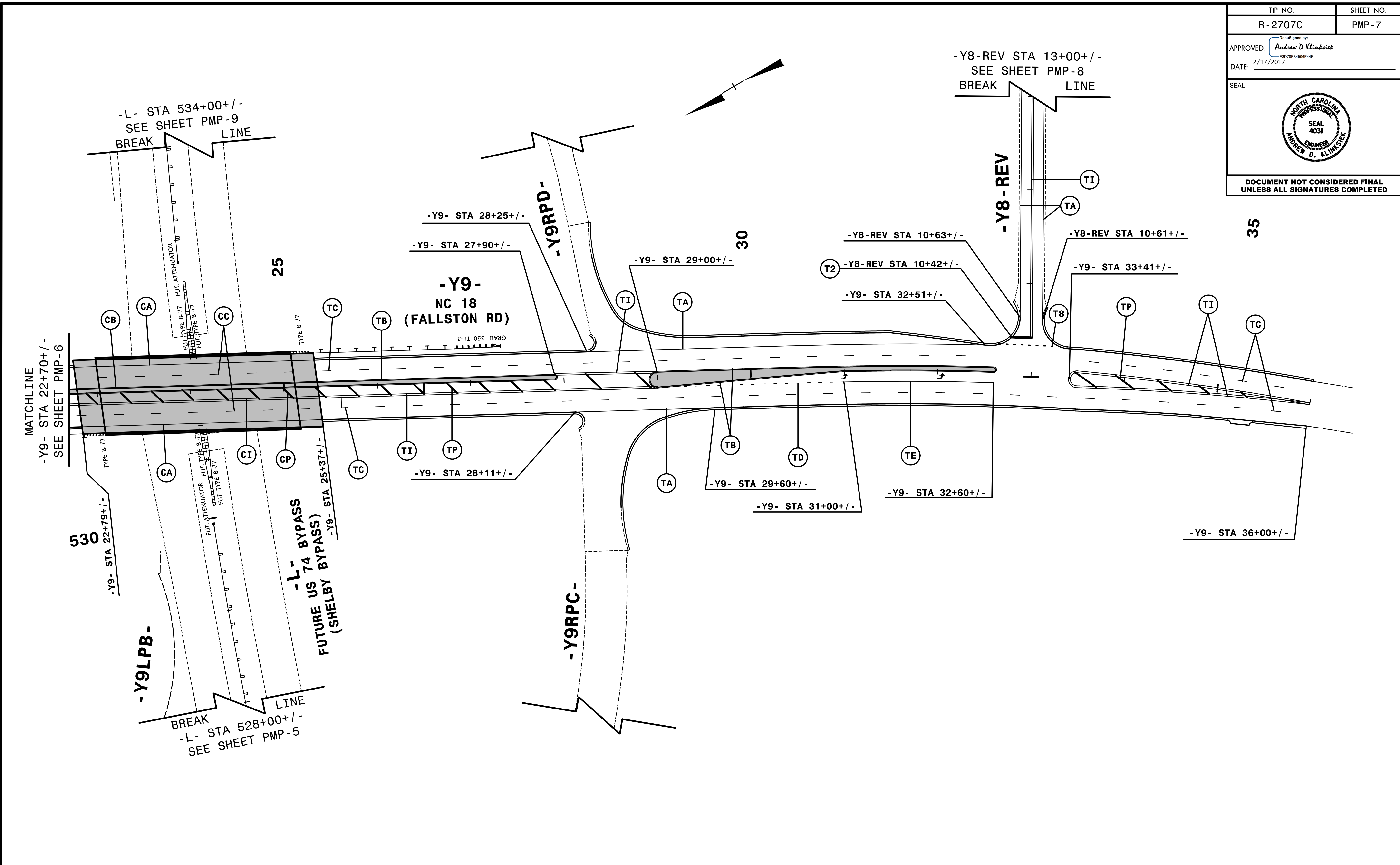

ENGINEER TO APPROVE LOCATION OF ALL UNSIGNALIZED STOPBARS.

NOTE: ALL LANE WIDTHS ARE 12' UNLESS OTHERWISE SHOWN.

\$\$\$SYTIME\$\$\$  
 \$\$\$DCN\$\$\$  
 \$\$\$USERNAME\$\$\$

**HNTB** HNTB NORTH CAROLINA, P.C.  
 343 E. SIX FORKS ROAD, SUITE 200  
 RALEIGH, NORTH CAROLINA 27609  
 NC License No: C-1554

**PAVEMENT MARKING DETAIL**

TIP NO. R-2707C	SHEET NO. PMP-8
APPROVED: <i>Andrew D. Klinkrick</i> E3078F8459E44B	
DATE: 2/17/2017	
SEAL	
	
DOCUMENT NOT CONSIDERED FINAL UNLESS ALL SIGNATURES COMPLETED	

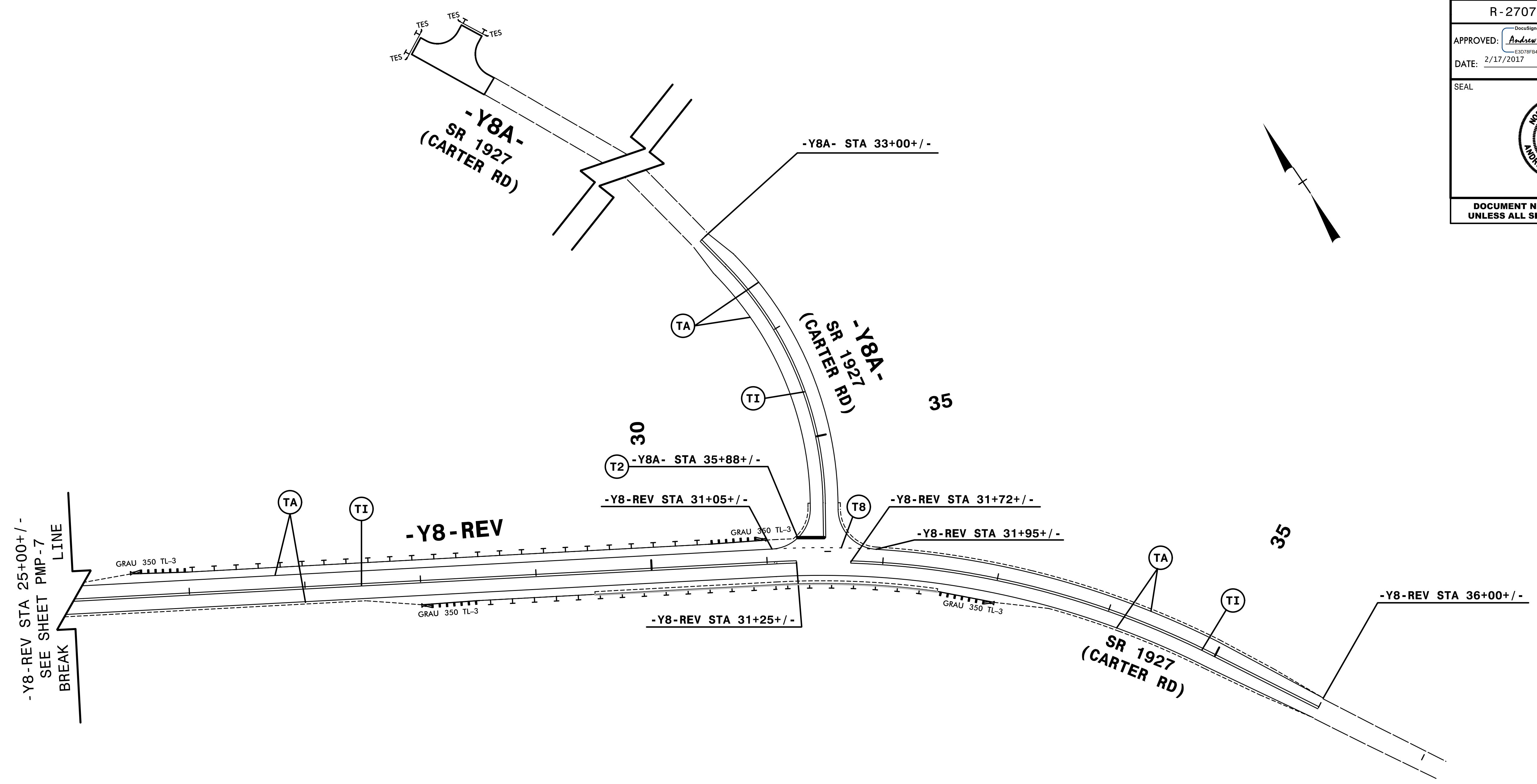

ENGINEER TO APPROVE LOCATION OF ALL UNSIGNALIZED STOPBARS.

NOTE: ALL LANE WIDTHS ARE 12' UNLESS OTHERWISE SHOWN.

SYTIME  
D:\CON  
USERNA

**HNTB** HNTB NORTH CAROLINA, P.C.  
343 E. SIX FORKS ROAD, SUITE 200  
RALEIGH, NORTH CAROLINA 27609  
NC LICENSE NO: C-1554

# PAVEMENT MARKING DETAIL

TIP NO. R-2707C	SHEET NO. PMP-9
APPROVED: <i>Andrew D. Klincksiek</i> E3078F8499E44B	
DATE: 2/17/2017	
SEAL	
	
DOCUMENT NOT CONSIDERED FINAL UNLESS ALL SIGNATURES COMPLETED	

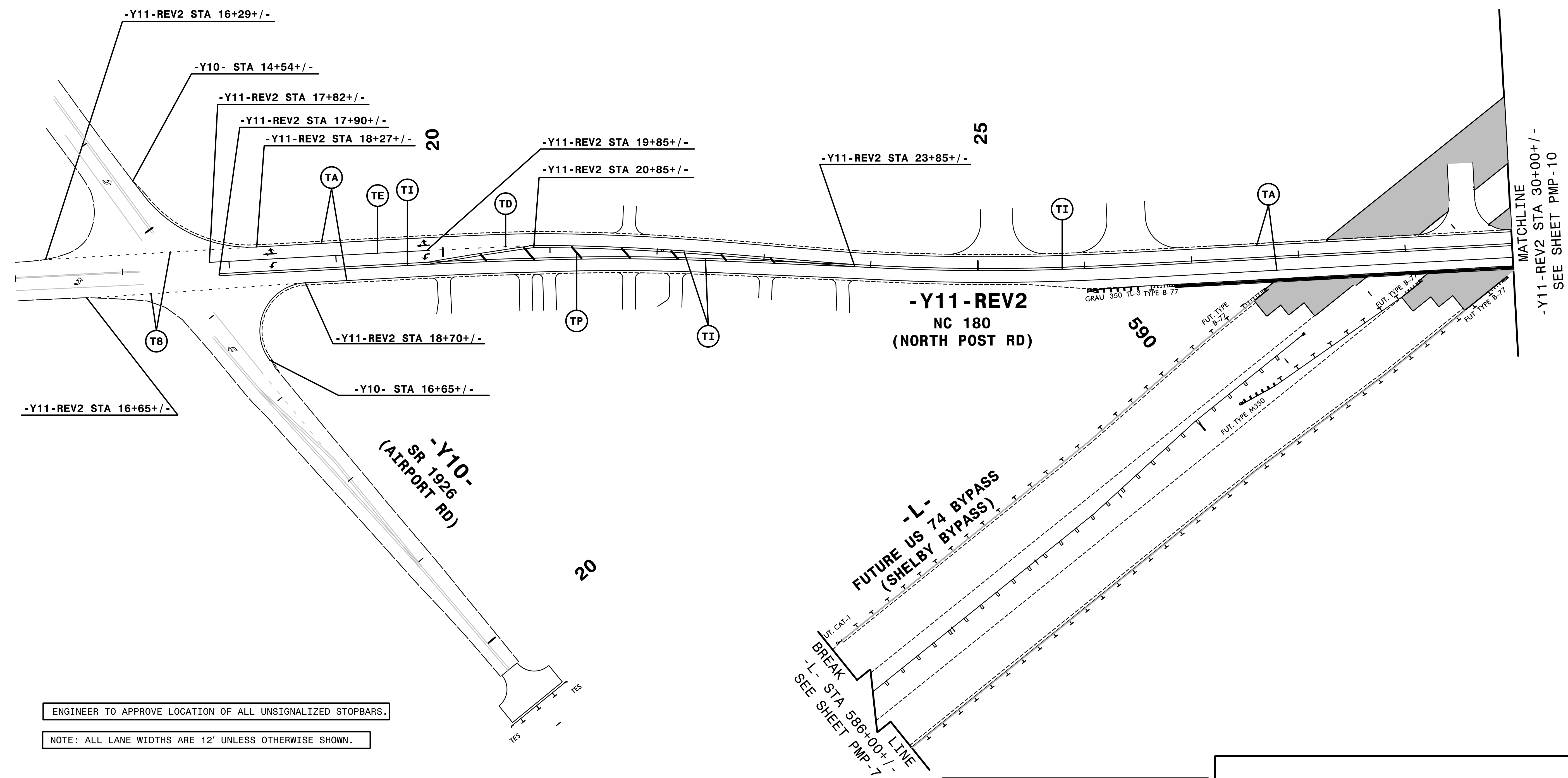
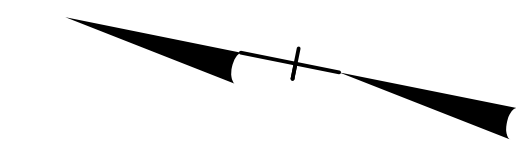

ENGINEER TO APPROVE LOCATION OF ALL UNSIGNALIZED STOPBARS.

NOTE: ALL LANE WIDTHS ARE 12' UNLESS OTHERWISE SHOWN.

\$\$\$\$\$SYTIME\$\$\$\$\$  
\$\$\$\$\$DUCN\$\$\$\$\$  
\$\$\$\$\$USERNAME\$\$\$\$\$

**HNTB** HNTB NORTH CAROLINA, P.C.  
343 E. SLX FORKS ROAD, SUITE 200  
RALEIGH, NORTH CAROLINA 27609  
NC LICENSE NO: C-1554

**PAVEMENT MARKING DETAIL**

MATCHLINE  
-Y11-REV2 STA 30+00+/-  
SEE SHEET PMP-10

TIP NO. R-2707C	SHEET NO. PMP-10
APPROVED: <i>Andrew D. Klincksiek</i> E3078FB459E44B	
DATE: 2/17/2017	
SEAL	
	
DOCUMENT NOT CONSIDERED FINAL UNLESS ALL SIGNATURES COMPLETED	

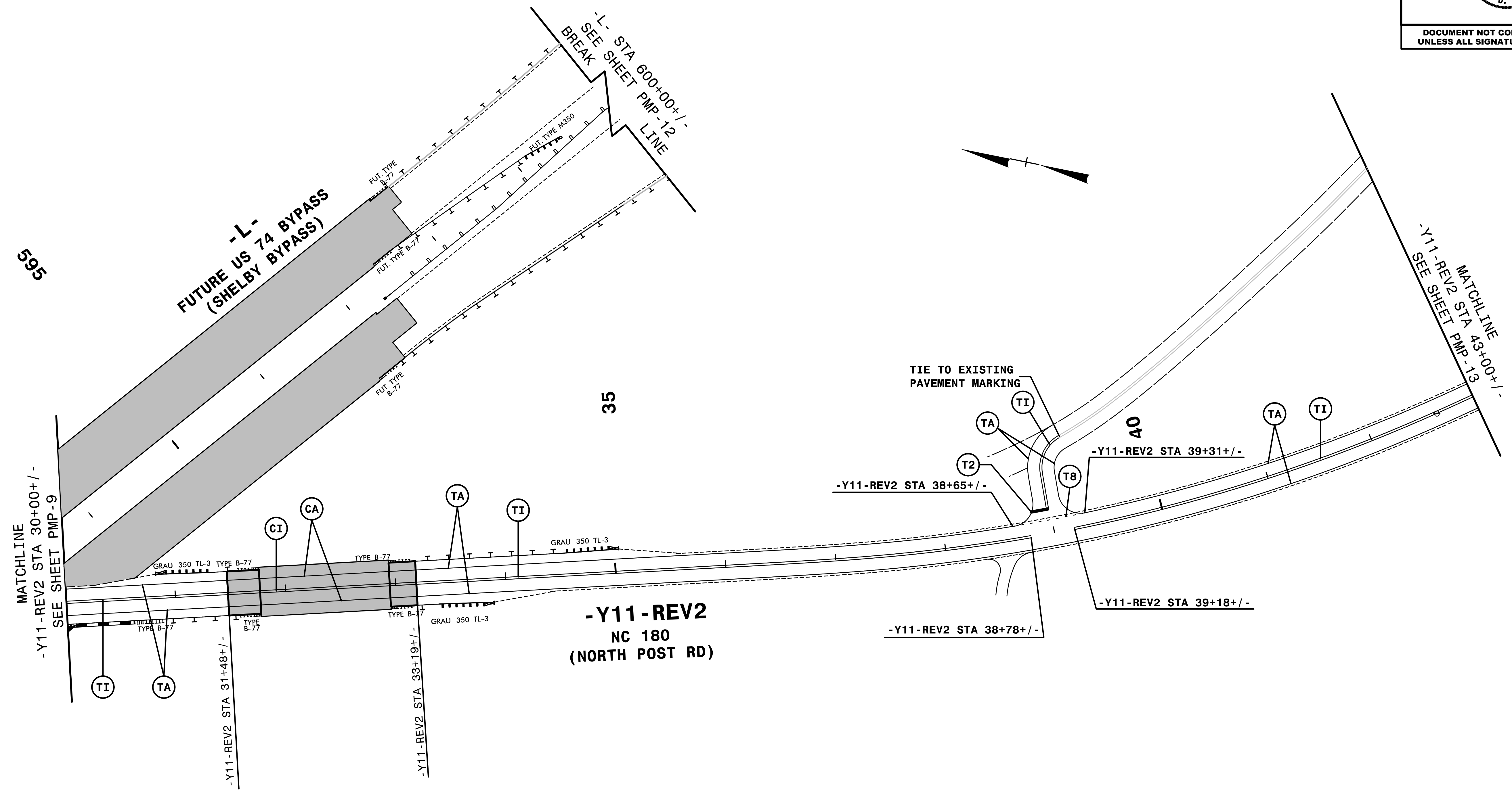

ENGINEER TO APPROVE LOCATION OF ALL UNSIGNALIZED STOPBARS.

NOTE: ALL LANE WIDTHS ARE 12' UNLESS OTHERWISE SHOWN.

\$\$\$SYTIME\$\$\$  
 \$\$\$CDON\$\$\$  
 \$\$\$USERNAME\$\$\$



**PAVEMENT MARKING DETAIL**

TIP NO. R-2707C	SHEET NO. PMP-11
APPROVED: <i>Andrew D. Klinkoski</i> E3078FB459E44B	
DATE: 2/17/2017	
SEAL	
	
DOCUMENT NOT CONSIDERED FINAL UNLESS ALL SIGNATURES COMPLETED	

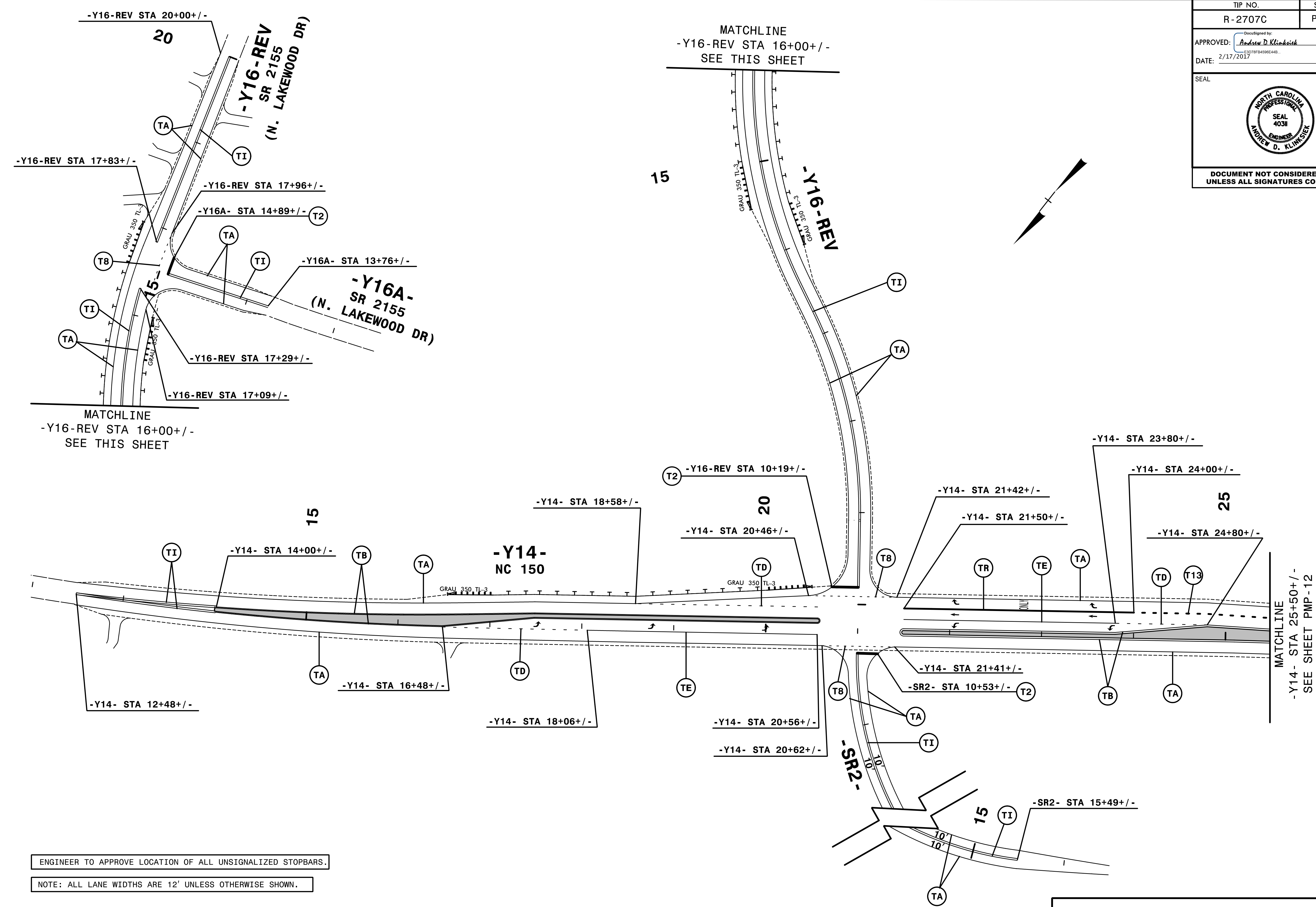

ENGINEER TO APPROVE LOCATION OF ALL UNSIGNALIZED STOPBARS.

NOTE: ALL LANE WIDTHS ARE 12' UNLESS OTHERWISE SHOWN.

**HNTB**  
 HNTB NORTH CAROLINA, P.C.  
 343 E. SIX FORKS ROAD, SUITE 200  
 RALEIGH, NORTH CAROLINA 27609  
 NC LICENSE NO: C-1554

# PAVEMENT MARKING DETAIL

\$\$\$\$\$SYTIME\$\$\$\$\$  
\$\$\$\$\$DCN\$\$\$\$\$  
\$\$\$\$\$USERNAME\$\$\$\$\$

TIP NO. R-2707C	SHEET NO. PMP-12
APPROVED: <i>Andrew D. Klincksiek</i> E3078FB4596E44B	
DATE: 2/17/2017	
SEAL 	
DOCUMENT NOT CONSIDERED FINAL UNLESS ALL SIGNATURES COMPLETED	

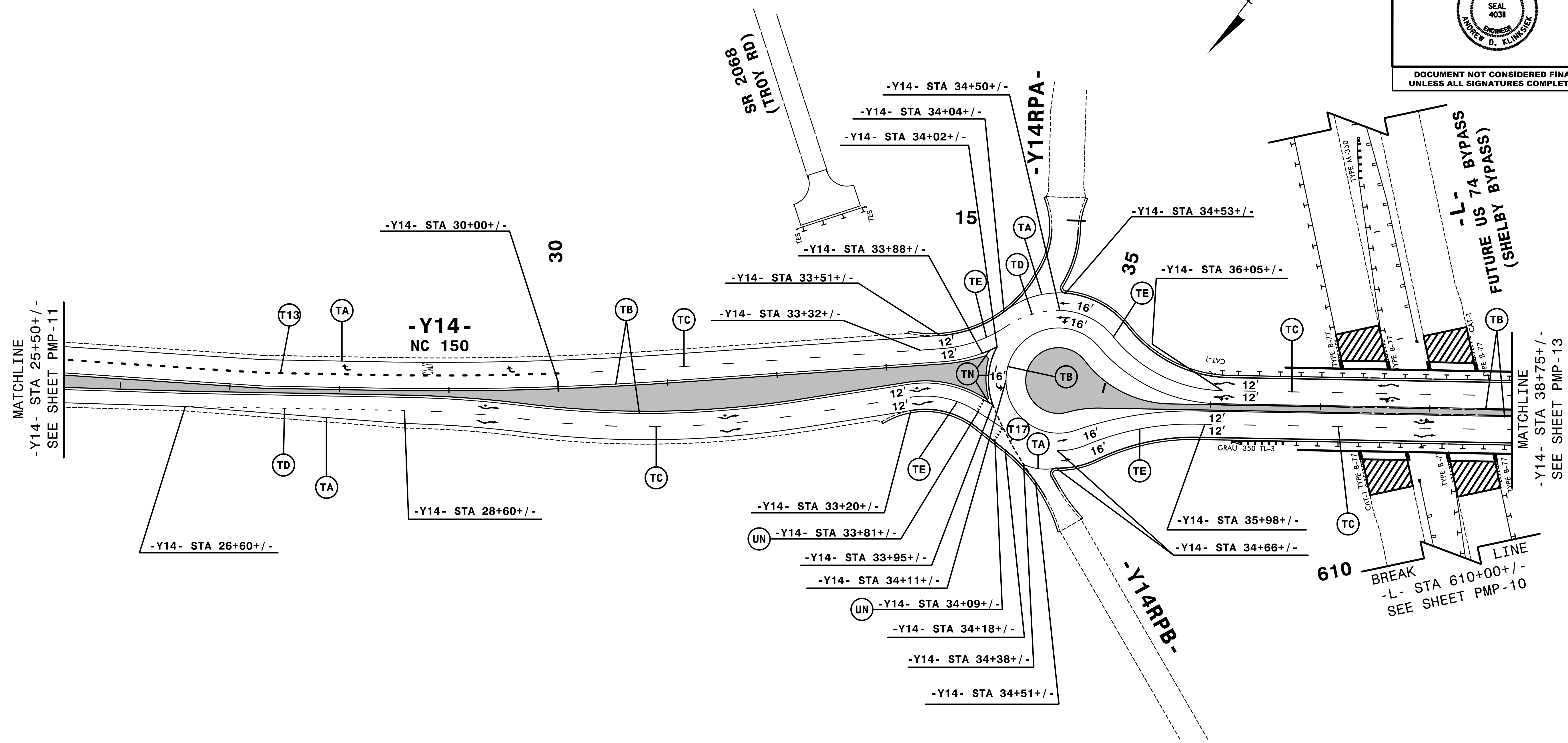

ROUNDBOUT PAVEMENT MARKING SYMBOLS			
(UU)	~	(WA)	~
(UW)	~	(WB)	~
(UZ)	~	(WC)	~

NOTE: ALL LANE WIDTHS ARE 12' UNLESS OTHERWISE SHOWN.

**HNTB** HNTB NORTH CAROLINA, P.C.  
343 E. SIX FORKS ROAD, SUITE 200  
RALEIGH, NORTH CAROLINA 27609  
NC LICENSE NO: C-1554

**PAVEMENT MARKING DETAIL**

\$\$\$\$SYTIME\$\$\$\$  
\$\$\$\$DCN\$\$\$\$  
\$\$\$\$USERNAME\$\$\$\$

TIP NO. R-2707C	SHEET NO. PMP-13
APPROVED: <i>Andrew D. Klincksiek</i> E3078F8499E44B	
DATE: 2/17/2017	
SEAL 	
DOCUMENT NOT CONSIDERED FINAL UNLESS ALL SIGNATURES COMPLETED	

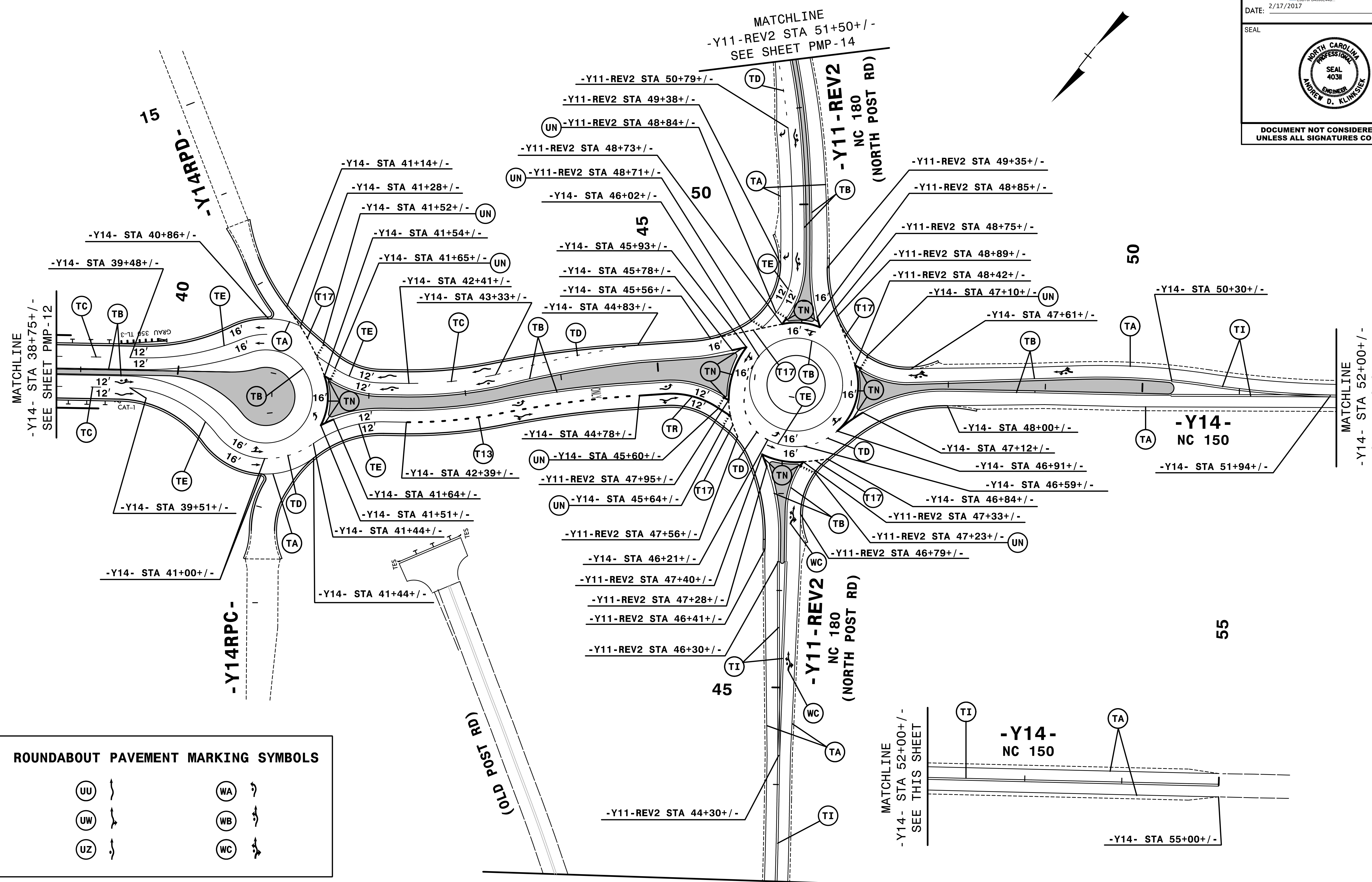

(UU)	~	(WA)	~
(UW)	~	(WB)	~
(UZ)	~	(WC)	~

NOTE: ALL LANE WIDTHS ARE 12' UNLESS OTHERWISE SHOWN.

**HNTB**  
 HNTB NORTH CAROLINA, P.C.  
 343 E. SIX FORKS ROAD, SUITE 200  
 RALEIGH, NORTH CAROLINA 27609  
 NC LICENSE NO: C-1554

**PAVEMENT MARKING DETAIL**

\$\$\$\$\$SYTIME\$\$\$\$\$  
 \$\$\$\$DCN\$\$\$\$\$  
 \$\$\$\$USERNAME\$\$\$\$\$



TIP NO. R-2707C	SHEET NO. PMP-14
APPROVED: <i>Andrew D. Klinck</i> E3078FB459E44B...	
DATE: 2/17/2017	
SEAL	
	
DOCUMENT NOT CONSIDERED FINAL UNLESS ALL SIGNATURES COMPLETED	

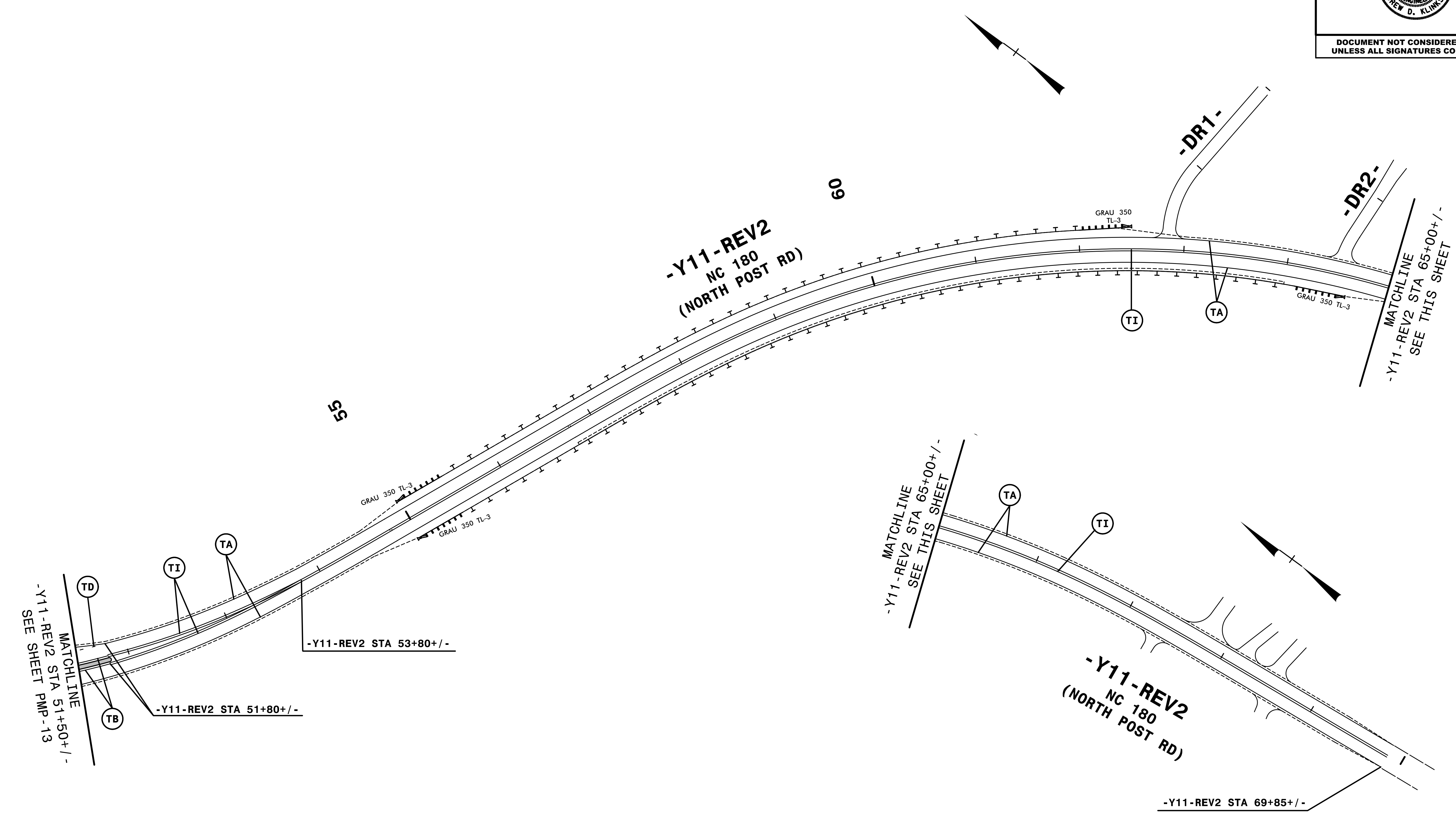

NOTE: ALL LANE WIDTHS ARE 12' UNLESS OTHERWISE SHOWN.

\$\$\$\$\$SYTIME\$\$\$\$\$  
\$\$\$\$\$DCN\$\$\$\$\$  
\$\$\$\$\$USERNAME\$\$\$\$\$

**HNTB** HNTB NORTH CAROLINA, P.C.  
343 E. SLX FORKS ROAD, SUITE 200  
RALEIGH, NORTH CAROLINA 27609  
NC LICENSE NO: C-1554

**PAVEMENT MARKING DETAIL**