

BAR TYPE		BILL OF MATERIAL				
BAR	NO.	SIZE	TYPE	LENGTH	WEIGHT	
A1	1708	#5	1	7'-2"	12767	
A2	1708	#5	1	7'-2"	12767	
A100	631	#8	STR.	10'-5"	17550	
A101	4	#8	STR.	8'-2"	87	
A102	4	#8	STR.	5'-11"	63	
A103	4	#8	STR.	3'-8"	39	
A104	4	#8	STR.	1'-5"	15	
A200	631	#8	STR.	10'-5"	17550	
A201	4	#8	STR.	8'-2"	87	
A202	4	#8	STR.	5'-11"	63	
A203	4	#8	STR.	3'-8"	39	
A204	4	#8	STR.	1'-5"	15	
A300	316	#4	STR.	10'-5"	2199	
A301	2	#4	STR.	8'-2"	11	
A302	2	#4	STR.	5'-10"	8	
A303	2	#4	STR.	3'-7"	5	
A400	316	#4	STR.	10'-5"	2199	
A401	2	#4	STR.	8'-2"	11	
A402	2	#4	STR.	5'-10"	8	
A403	2	#4	STR.	3'-7"	5	
B1	854	#4	STR.	9'-1"	5182	
B2	854	#4	STR.	6'-0"	3423	
C1	600	#4	STR.	28'-4"	11356	
S1	6	#8	STR.	11'-6"	185	
S2	6	#8	STR.	11'-6"	185	
G1	4	#5	STR.	11'-6"	48	
G2	4	#6	STR.	1'-11"	12	
G3	52	#6	STR.	2'-11"	228	
REINFORCING STEEL					86,107 LBS	

SPLICE CHART		
BAR	SIZE	SPLICE LENGTH
B1	#4	1'-9"
C1	#4	1'-11"

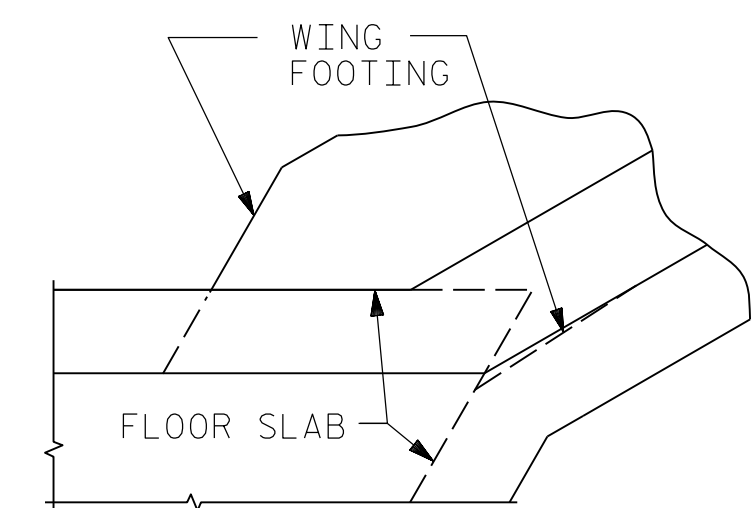
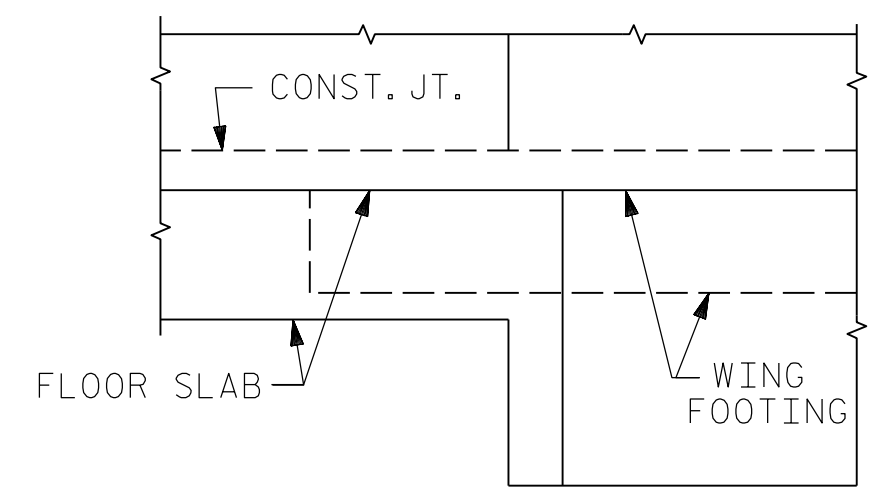
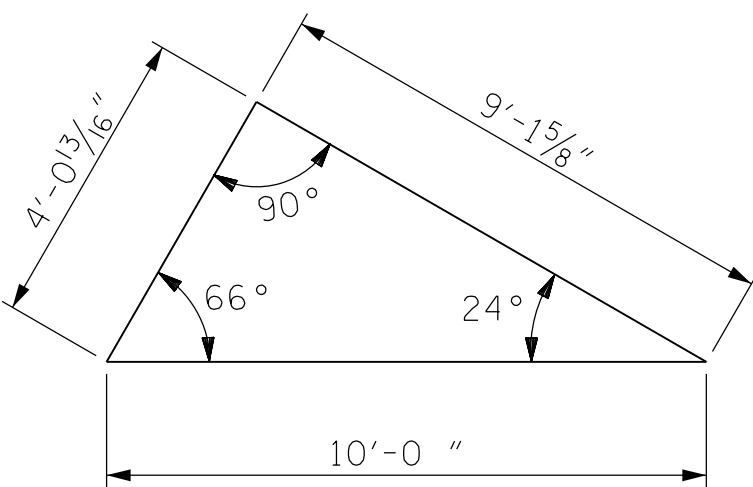
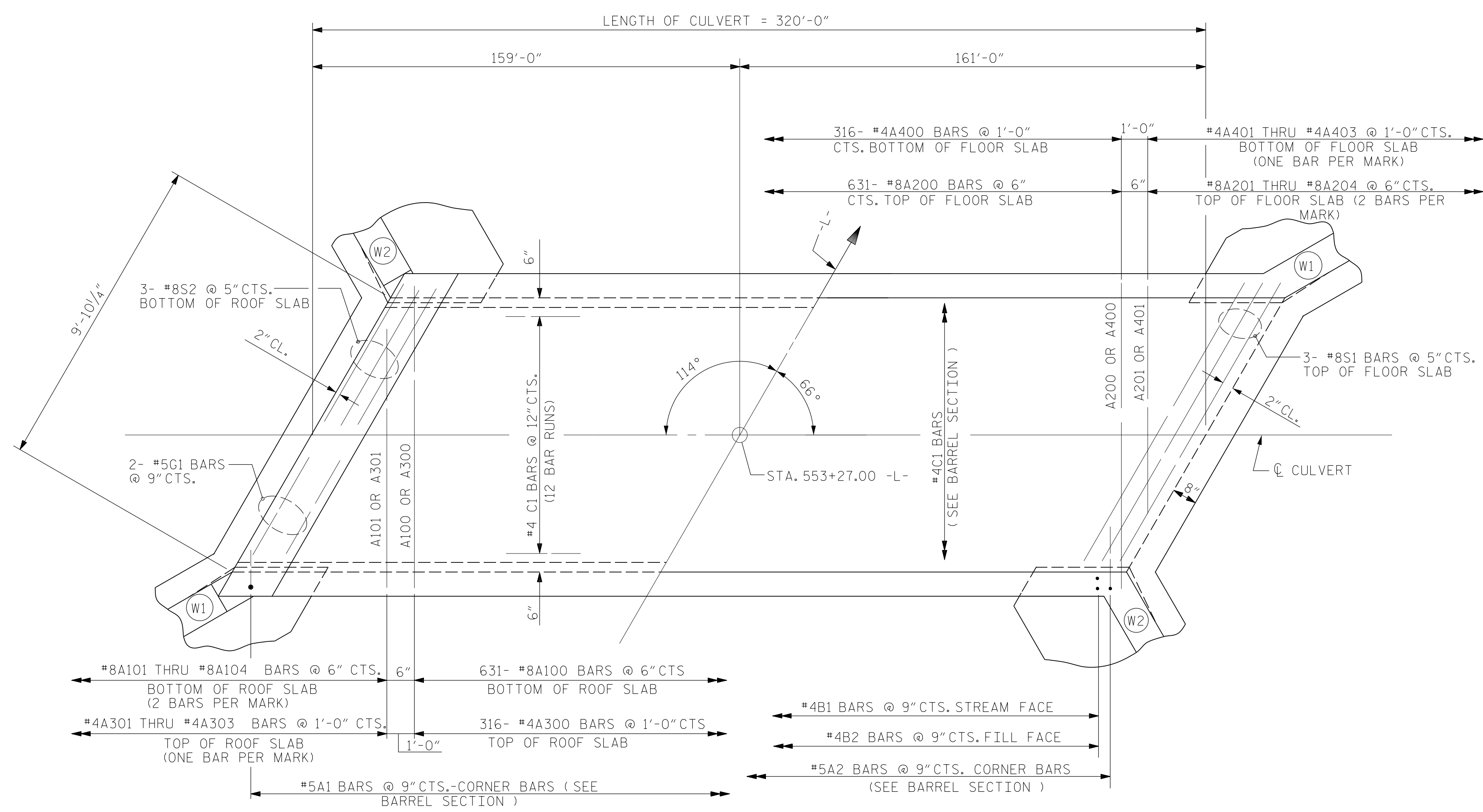
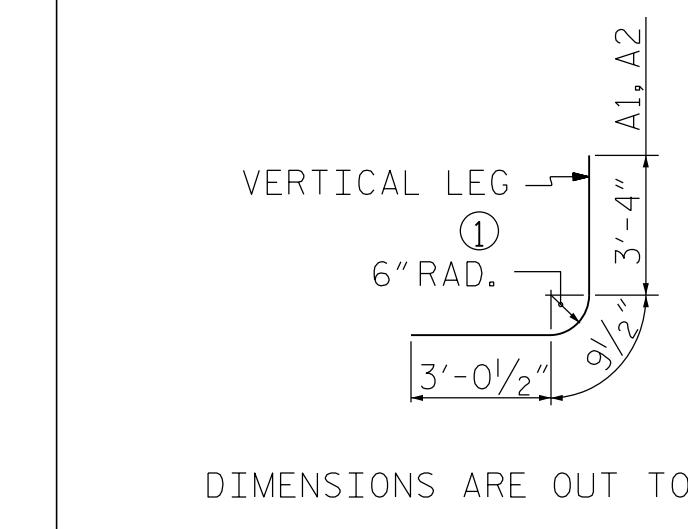

CONNECTION OF WING FOOTING  
AND FLOOR SLAB WHEN SLAB  
IS THICKER THAN FOOTING

PROJECT NO. R-2707C  
CLEVELAND COUNTY  
 STATION: 553+27.00 -L-  
 SHEET 3 OF 5



2/10/2017  
**DOCUMENT NOT CONSIDERED FINAL  
 UNLESS ALL SIGNATURES COMPLETED**

**STEWART**  
 Firm License No. C-1051  
 421 Fayetteville St,  
 Suite 400  
 Raleigh, NC 27601  
 T 919.380.8750  
 www.stewartinc.com

STATE OF NORTH CAROLINA DEPARTMENT OF TRANSPORTATION RALEIGH					
SINGLE 9 FT. X 7 FT. CONCRETE BOX CULVERT 66° SKEW					
REVISIONS					SHEET NO.
NO.	BY:	DATE:	NO.	BY:	DATE:
1			3		
2			4		
					TOTAL SHEETS 5

DRAWN BY: H.ASSFOURA DATE: 11/16  
 CHECKED BY: D. RUGGLES DATE: 12/16  
 DESIGN ENGINEER OF RECORD: D. RUGGLES DATE: 12/16

R 2707C-SITE 3  
 2/10/2017  
 \\413-005.R2707C-SMU-SP03-C13-3.dgn  
 USER:dfault