

BAR TYPE		BILL OF MATERIAL				
BAR	NO.	SIZE	TYPE	LENGTH	WEIGHT	
A1	1272	#5	1	7'-2"	9508	
A2	1272	#5	1	7'-2"	9508	
A100	472	#8	STR.	9'-9"	12288	
A101	2	#8	STR.	7'-11"	42	
A102	2	#8	STR.	6'-1"	32	
A103	2	#8	STR.	4'-3"	23	
A104	2	#8	STR.	2'-5"	13	
A200	472	#8	STR.	9'-9"	12288	
A201	2	#8	STR.	7'-11"	42	
A202	2	#8	STR.	6'-1"	32	
A203	2	#8	STR.	4'-3"	23	
A204	2	#8	STR.	2'-5"	13	
A300	252	#4	STR.	9'-9"	1641	
A301	2	#4	STR.	6'-3"	8	
A302	2	#4	STR.	2'-10"	4	
A400	252	#4	STR.	9'-9"	1641	
A401	2	#4	STR.	6'-3"	8	
A402	2	#4	STR.	2'-10"	4	
B1	636	#4	STR.	10'-0"	4248	
B2	636	#4	STR.	6'-11"	2939	
C1	588	#4	STR.	28'-4"	11132	
S1	6	#8	STR.	10'-5"	168	
S2	6	#8	STR.	10'-5"	168	
G1	4	#5	STR.	10'-5"	44	
G2	6	#6	STR.	1'-11"	17	
REINFORCING STEEL					65,834 LBS	

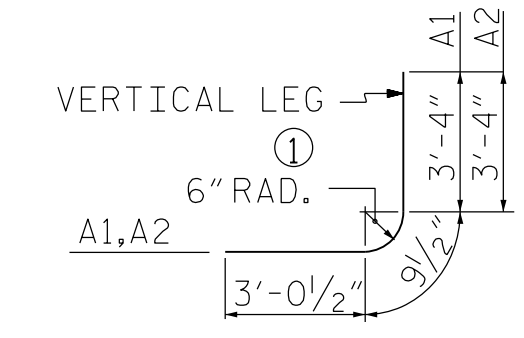

DIMENSIONS ARE OUT TO OUT

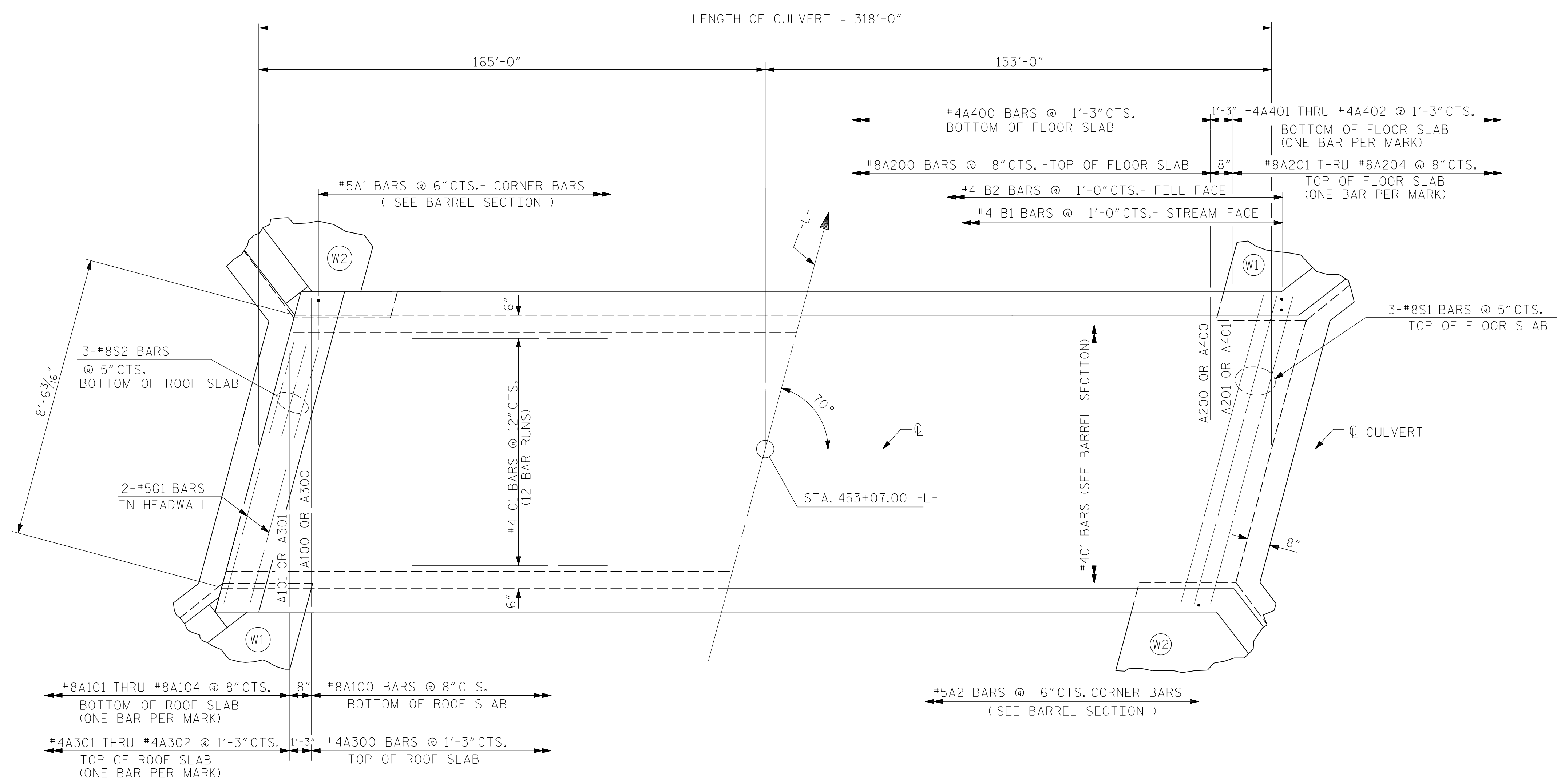

PART PLAN - ROOF SLAB PART PLAN - FLOOR SLAB

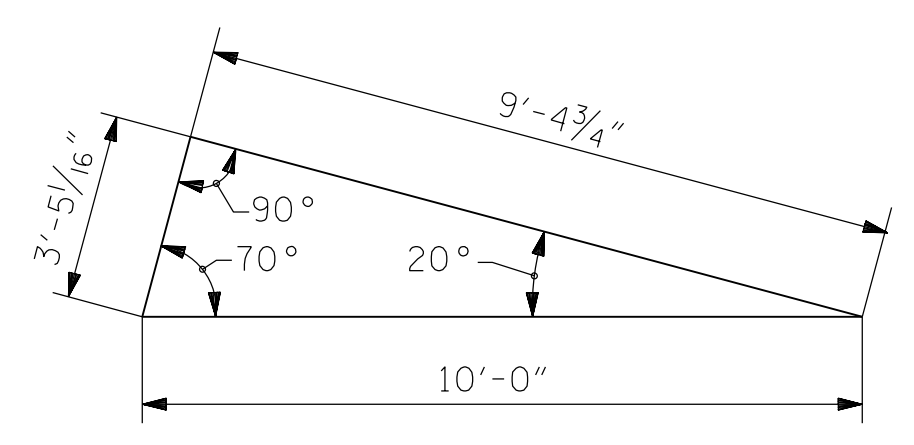

SKIEW TRIANGLE

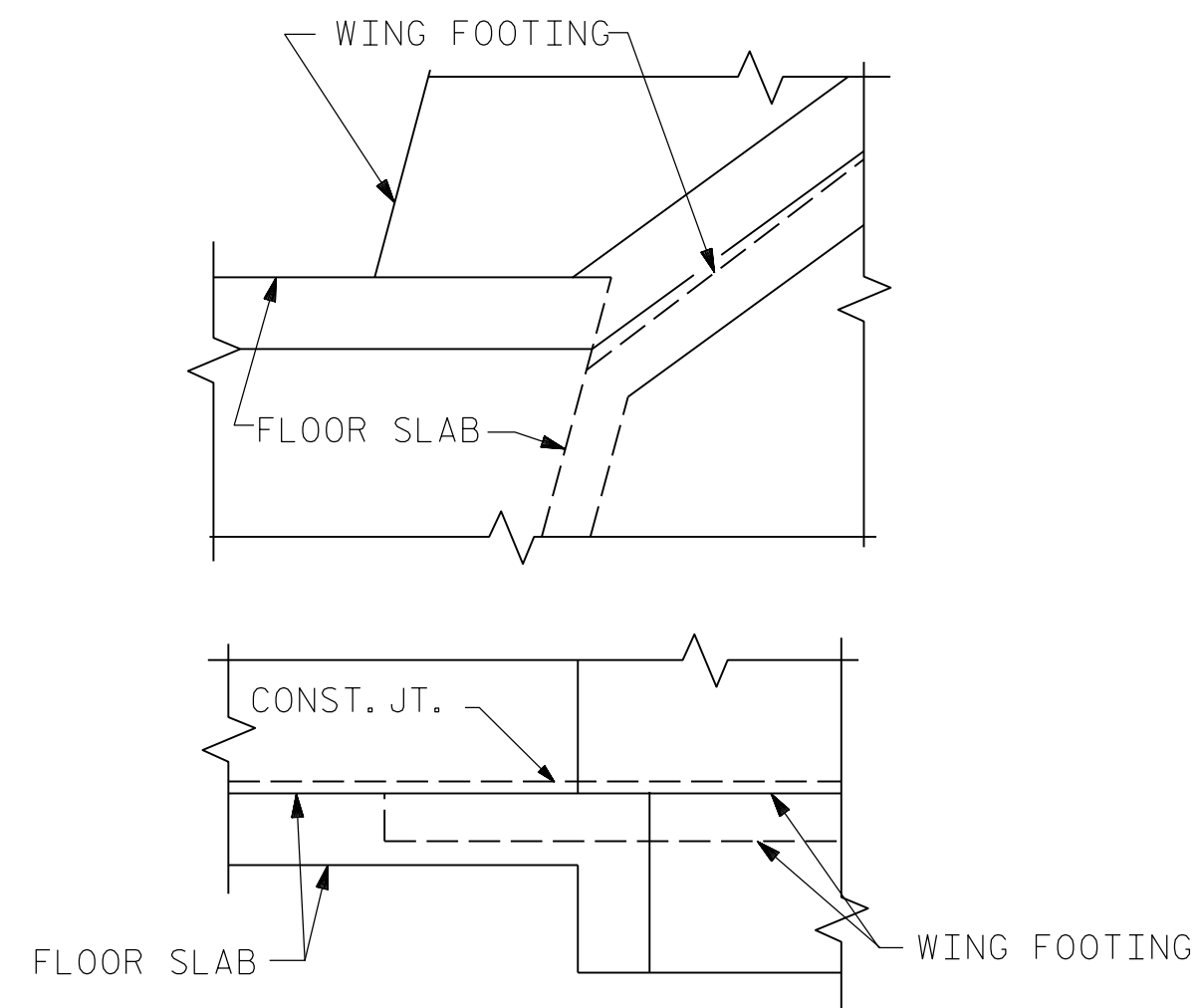

DETAIL
CONNECTION OF WING FOOTING
AND FLOOR SLAB WHEN SLAB
IS THICKER THAN FOOTING

SPLICE CHART		
BAR	SIZE	SPLICE LENGTH
B1	#4	1'-9"
C1	#4	1'-11"

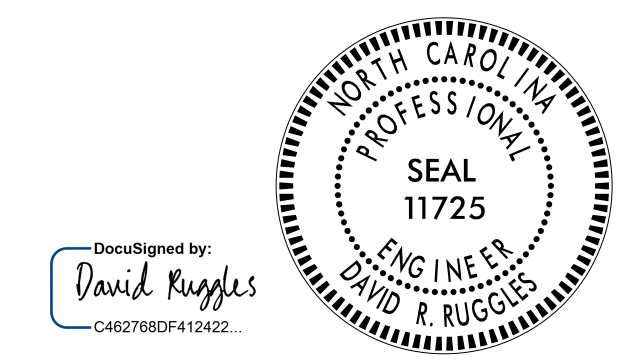

2/10/2017
**DOCUMENT NOT CONSIDERED FINAL
UNLESS ALL SIGNATURES COMPLETED**

STEWART
Firm License No. C-1051
421 Fayetteville St,
Suite 400
Raleigh, NC 27601
T 919.380.8750
www.stewartinc.com

PROJECT NO. R-2707C
CLEVELAND COUNTY
STATION: 453+07.00 -L-

SHEET 3 OF 5
STATE OF NORTH CAROLINA
DEPARTMENT OF TRANSPORTATION
RALEIGH
SINGLE 8 FT. X 8 FT.
CONCRETE BOX CULVERT
70°SKEW

REVISIONS						SHEET NO.
NO.	BY:	DATE:	NO.	BY:	DATE:	C12-03
1			3			TOTAL SHEETS
2			4			5

DRAWN BY: H.ASSFOURA DATE: 11/16
CHECKED BY: D. RUGGLES DATE: 11/16
DESIGN ENGINEER OF RECORD: D. RUGGLES DATE: 11/16

R 2707C-SITE 3
2/10/2017
\\412-005_R2707C-SMU_SPO3-C12-3.dgn
USER:deFault