

- NOTES:**
1. FOR NOTES, SEE SHEET 3 OF 3.
 2. FOR SECTIONS A-A AND B-B, SEE SHEET 3 OF 3.
 3. FOR DETAILS "B" AND "C", SEE SHEET 3 OF 3.
 4. CONTRACTOR SHALL VERIFY WING WALL LENGTH BASED ON MSE WALL DESIGN AND MODIFY THE WING WALL LENGTH ACCORDINGLY SUCH THAT THE WING WALL AND 1" EXPANSION JOINT MATERIAL IS FLUSH WITH THE BACK OF THE MSE WALL PANEL.

ELEVATION
(LOOKING IN THE DIRECTION OF STATIONING)

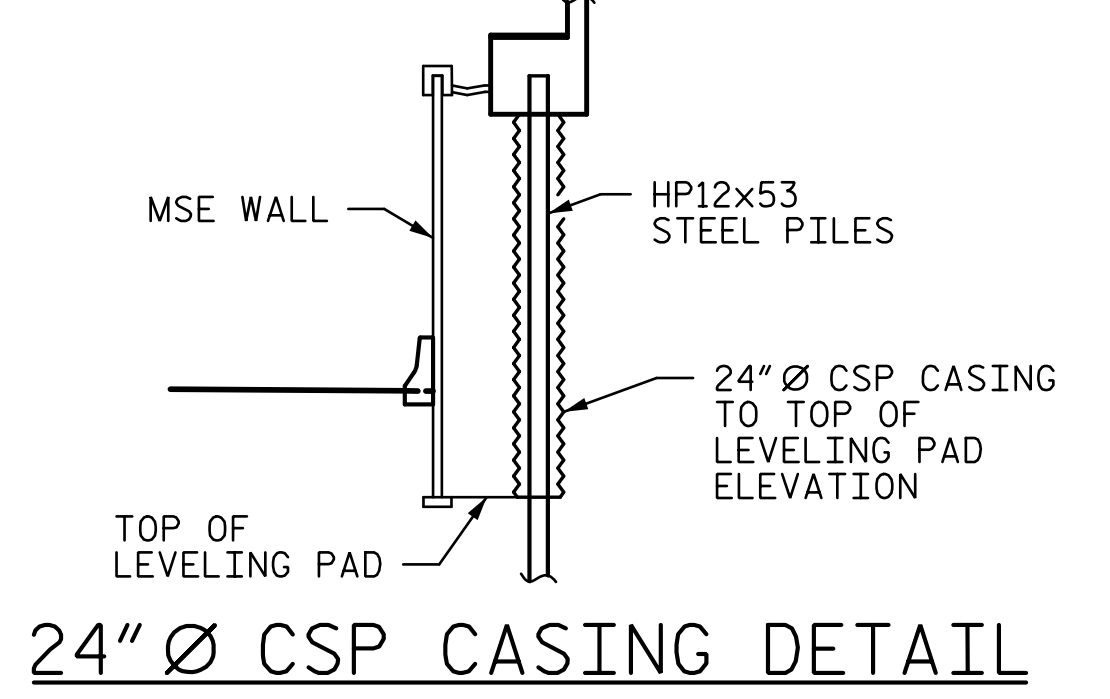

DOCUMENT NOT CONSIDERED FINAL UNLESS ALL SIGNATURES COMPLETED

DocuSigned by:
Tony R. Laws, Jr.
CARCE06FB76AF7
12/13/2016

STATE OF NORTH CAROLINA
DEPARTMENT OF TRANSPORTATION
RALEIGH

**SUBSTRUCTURE
END BENT 2**

(SITE 6R)

| REVISIONS | | | | SHEET NO. | |
|-----------|-----|-------|-----|-----------|-------|
| NO. | BY: | DATE: | NO. | BY: | DATE: |
| 1 | | | 3 | | |
| 2 | | | 4 | | |

DRAWN BY: **MBC** DATE: **9-16**

CHECKED BY: **TJT** DATE: **10-16**

DESIGN ENGINEER OF RECORD: **V. WU** DATE: **10-16**

SHEET NO. **S8-39**

TOTAL SHEETS **44**

R:\408_077_R2707C_SMU_EB201_S8-39.dgn 12/13/2016 7:03:41 PM aveyac