

BEARING STIFFENER DETAIL

■ INCREASE BEARING STIFFENER WIDTH AS REQUIRED WHEN USED AS A CONNECTOR PLATE. INCREASE BEARING STIFFENER THICKNESS AS REQUIRED TO MAINTAIN WIDTH TO THICKNESS RATIO NO LARGER THAN 10.5.

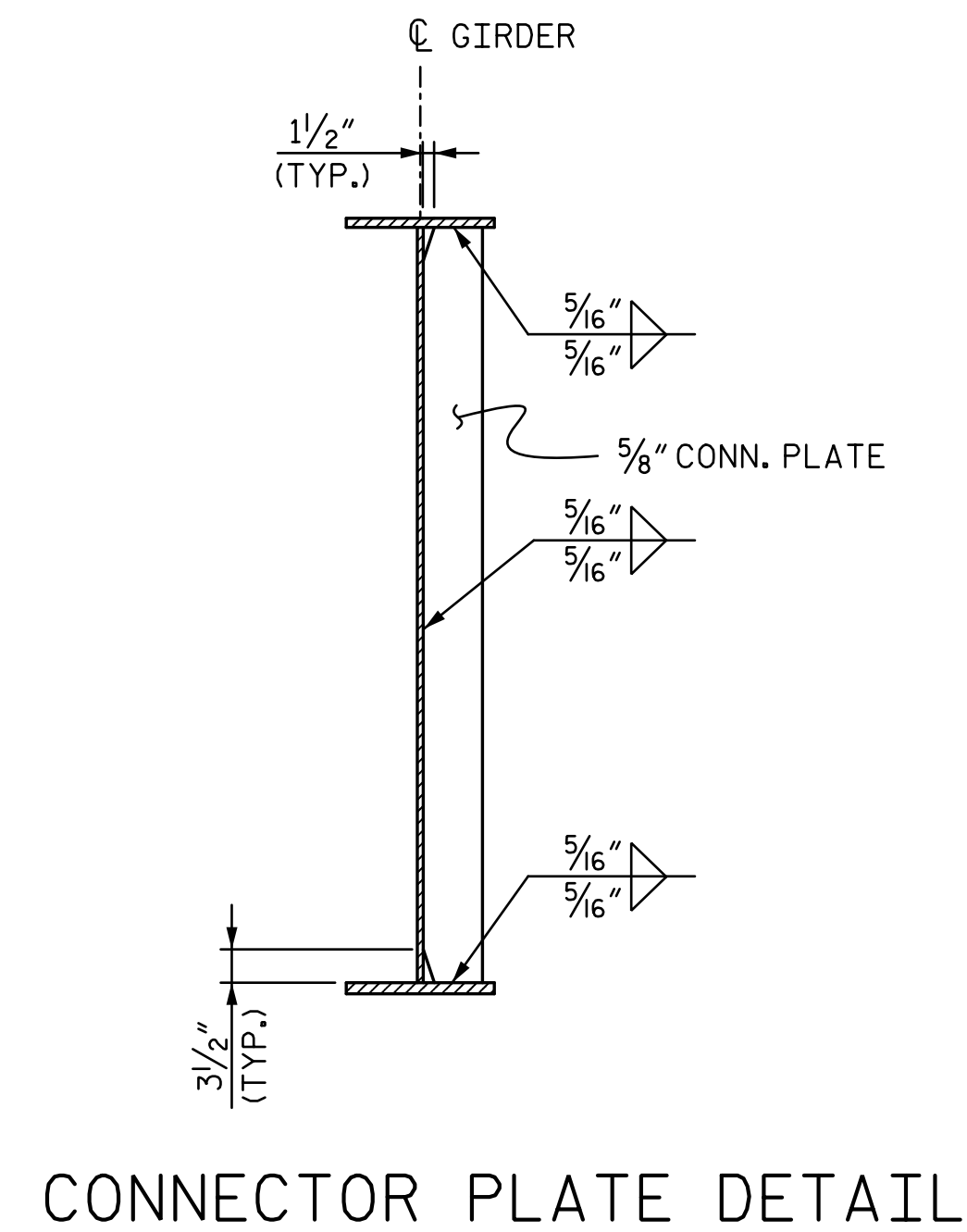

CONNECTOR PLATE DETAIL

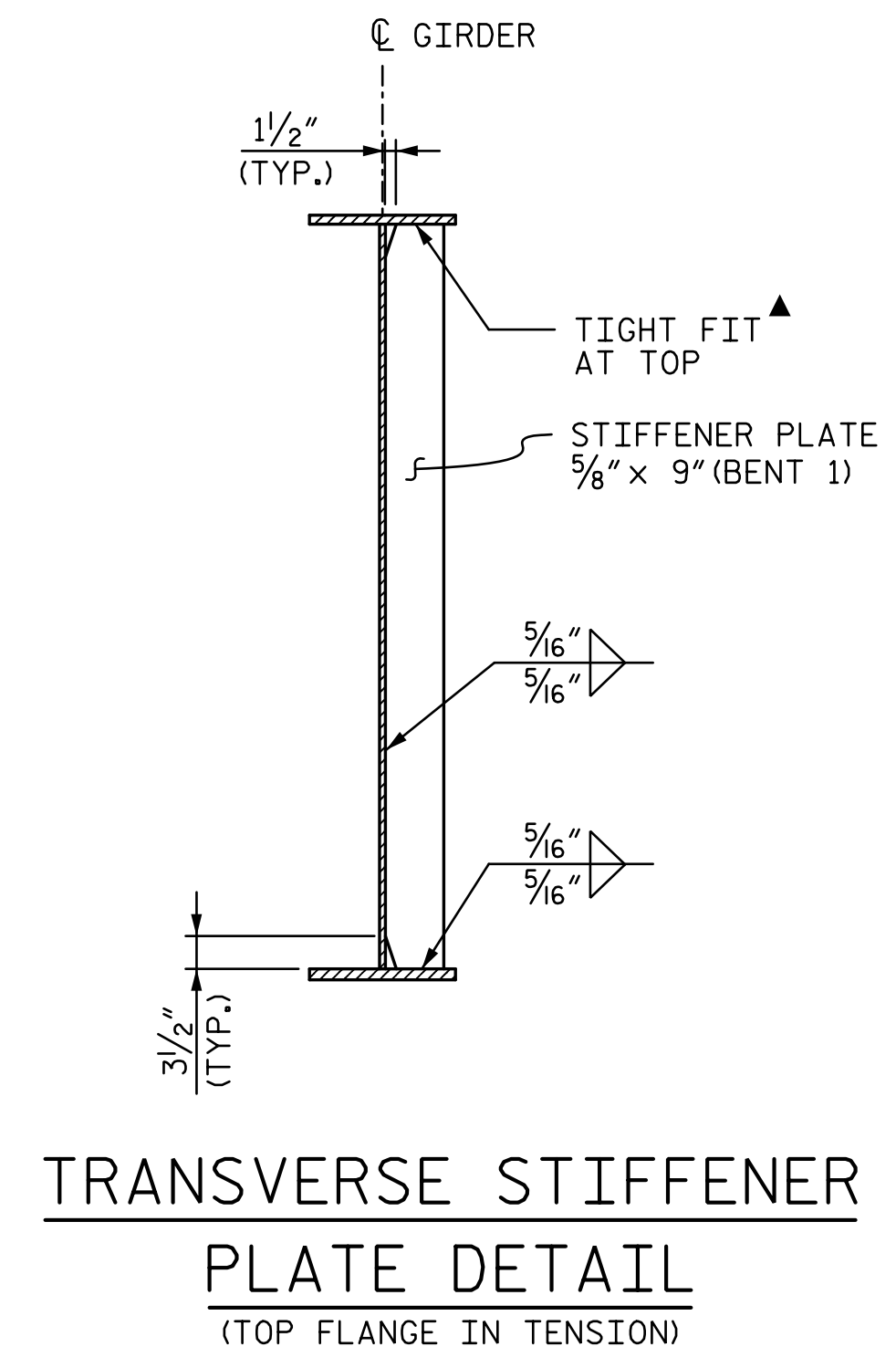

TRANSVERSE STIFFENER PLATE DETAIL (TOP FLANGE IN TENSION)

▲ IF TRANSVERSE STIFFENERS ARE USED FOR CONNECTOR PLATES, WELD TOP & BOTTOM OF STIFFENERS TO FLANGES. INCREASE STIFFENER WIDTH AS REQUIRED WHEN USED AS A CONNECTOR PLATE. INCREASE STIFFENER THICKNESS AS REQUIRED TO MAINTAIN WIDTH TO THICKNESS RATIO NO LARGER THAN 14.0.

STRUCTURAL STEEL NOTES:

1. ALL STRUCTURAL STEEL SHALL BE AASHTO M270, GRADE 50W AND PAINTED IN ACCORDANCE WITH SYSTEM 4 OF ARTICLE 442-8 OF THE STANDARD SPECIFICATIONS UNLESS OTHERWISE NOTED ON THE PLANS.
2. ALL DIMENSIONS SHOWN ARE HORIZONTAL OR VERTICAL, UNLESS OTHERWISE NOTED.
3. ALL FIELD CONNECTIONS SHALL BE 7/8" DIA. HIGH STRENGTH BOLTS UNLESS OTHERWISE NOTED.
4. STIFFENERS ARE NOT REQUIRED ON THE OUTSIDE OF EXTERIOR BEAMS.
5. BEARING STIFFENERS ARE TO BE PLACED NORMAL TO THE WEB OF THE GIRDER AND SHALL BE PLUMB.
6. PERMITTED FLANGE AND WEB SHOP SPLICES SHALL NOT BE LOCATED WITHIN 15 FEET OF MAXIMUM DEAD LOAD DEFLECTION (NOR WITHIN 15 FEET OF INTERMEDIATE BEARINGS OF CONTINUOUS UNITS). KEEP 2 FEET MINIMUM BETWEEN WEB AND FLANGE SHOP SPLICES. KEEP 6" MINIMUM BETWEEN CONNECTOR PLATE OR TRANSVERSE STIFFENER WELDS AND WEB OR FLANGE SHOP SPLICES.
7. STUDS ON GIRDERS MAY BE SHIFTED UP TO 1" IF NECESSARY TO CLEAR FLANGE SPLICE WELD.
8. TENSION ON THE AASHTO M164 BOLTS SHALL BE CALIBRATED USING DIRECT TENSION INDICATOR WASHERS IN ACCORDANCE WITH ARTICLE 440-8 OF THE STANDARD SPECIFICATIONS.
9. END OF BEAMS AND GIRDERS SHALL BE PLUMB.
10. BEARING STIFFENER MAY REQUIRE COPING IF WIDER THAN BOTTOM FLANGE.
11. FABRICATORS SHALL DETAIL CROSSFRAME MEMBERS AND CONNECTIONS FOR FULL DEAD LOAD FIT UP. GIRDERS SHOULD BE PLUMB AFTER FULL AMOUNT OF DEAD LOAD IS APPLIED.

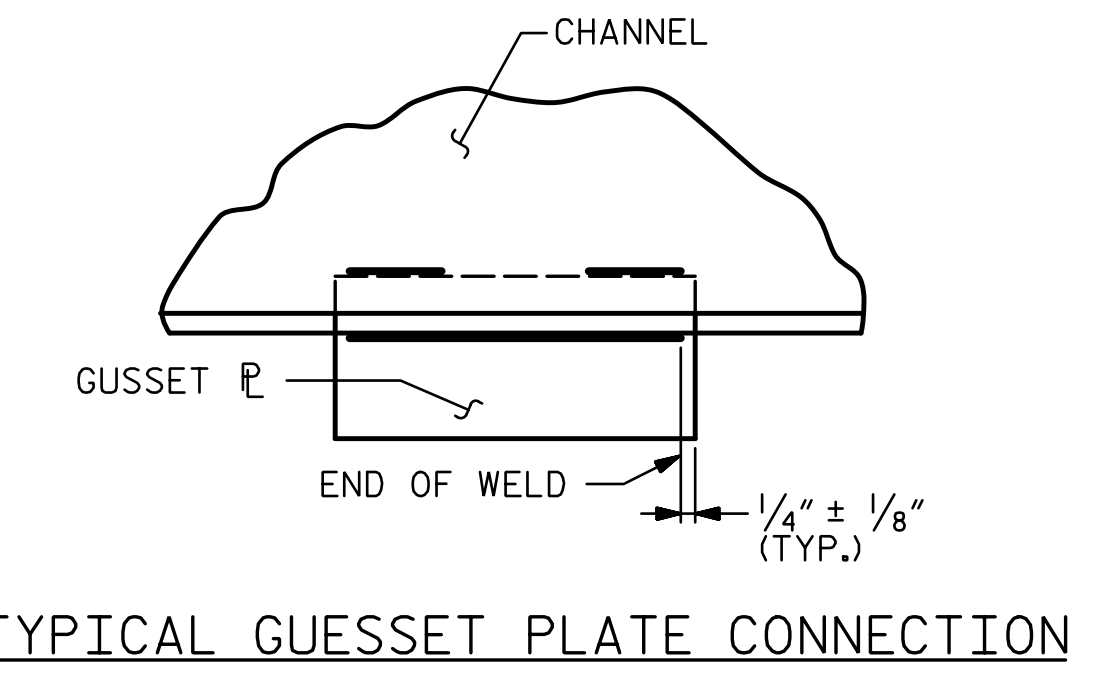

TYPICAL GUSSET PLATE CONNECTION

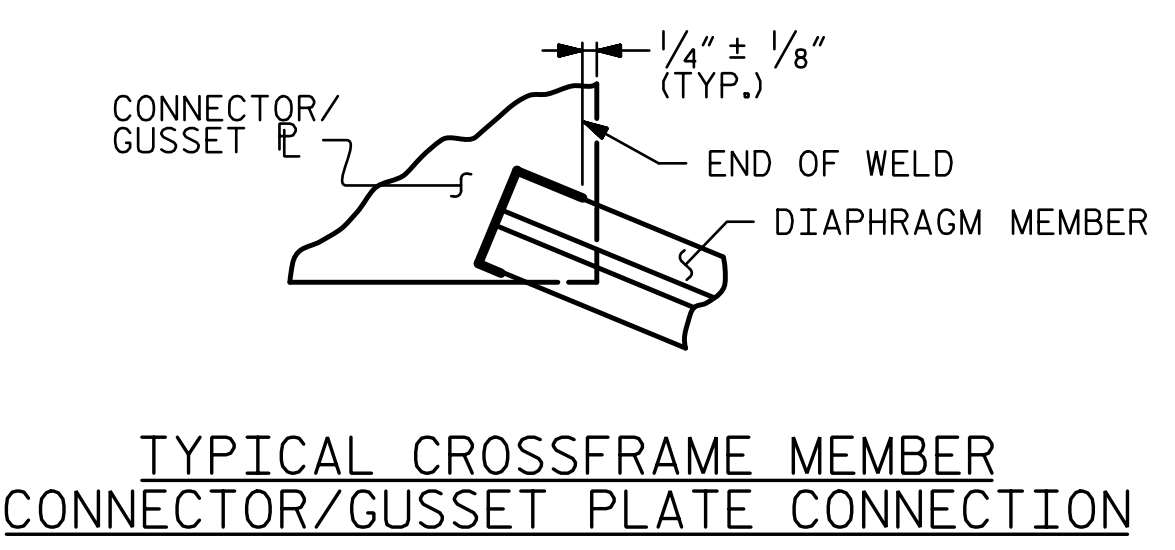

TYPICAL CROSSFRAME MEMBER CONNECTOR/GUSSET PLATE CONNECTION

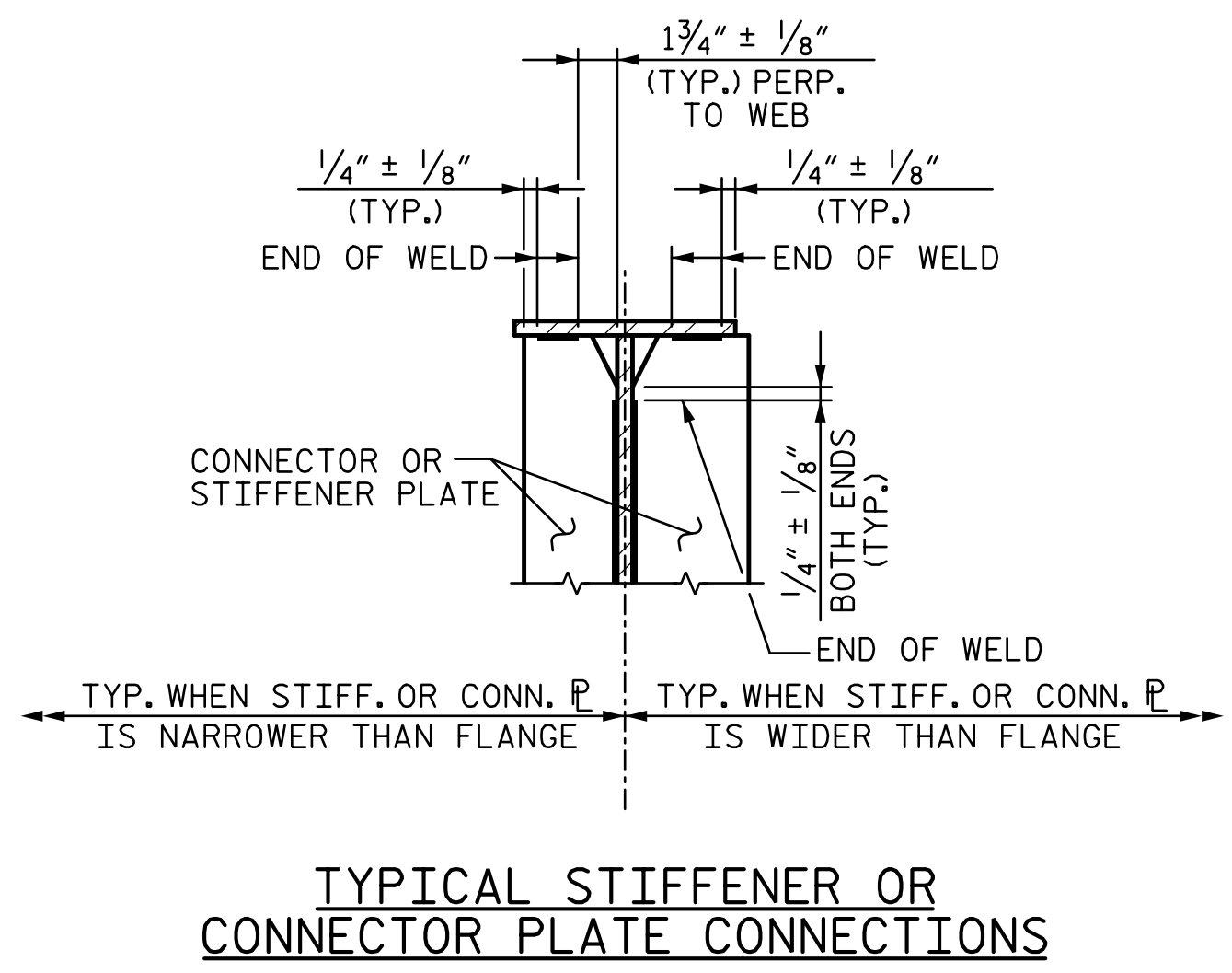

TYPICAL STIFFENER OR CONNECTOR PLATE CONNECTIONS

WELD TERMINATION DETAILS

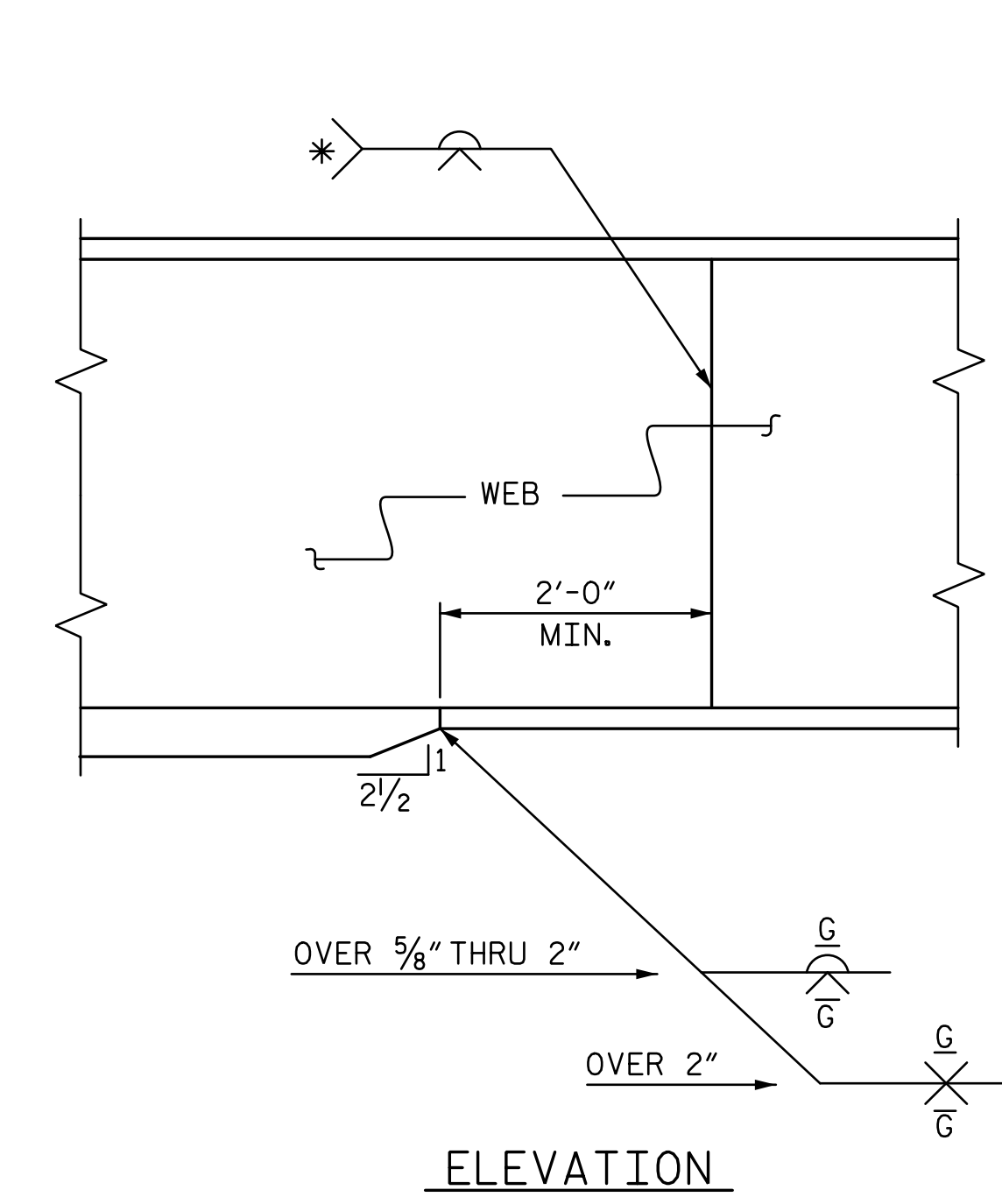

TYPICAL FLANGE AND WEB BUTT JOINT

* GRIND SMOOTH AND FLUSH ON OUTER FACE OF EXTERIOR BEAMS /GIRDERS

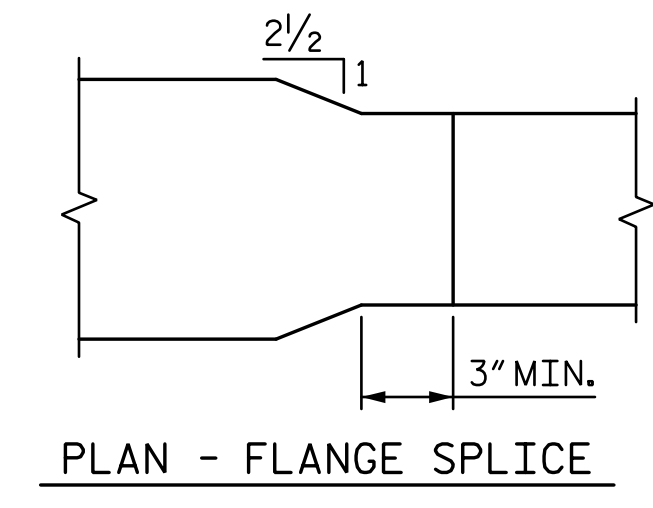

PROJECT NO. R-2707C
CLEVELAND COUNTY
 STATION: 596+50.98 -L-
 SHEET 4 OF 8

DOCUMENT NOT CONSIDERED FINAL UNLESS ALL SIGNATURES COMPLETED		STATE OF NORTH CAROLINA DEPARTMENT OF TRANSPORTATION RALEIGH				SHEET NO. SB-16
		SUPERSTRUCTURE STRUCTURAL STEEL DETAILS				TOTAL SHEETS 44
		(SITE 6R)				
REVISIONS						
NO.	BY:	DATE:	NO.	BY:	DATE:	
1			3			
2			4			

R:\408_031_R2707C_SML_SSD04_S8-16.dgn 7:03:28 PM 12/13/2016

DRAWN BY : <u>VMW</u>	DATE : <u>10-16</u>	DESIGN ENGINEER OF RECORD: <u>V. WU</u>	DATE : <u>10-16</u>
CHECKED BY : <u>TRL</u>	DATE : <u>10-16</u>		