

PLAN

- NOTES:**
1. STIRRUPS AND "U BARS" IN CAP MAY BE SHIFTED SLIGHTLY AS NECESSARY TO CLEAR ANCHOR BOLTS.
 2. HOOKS ON BARS MAY BE TURNED AS NECESSARY FOR PLACING REINFORCING STEEL.
 3. SEE "GENERAL DRAWING GENERAL NOTES" SHEET FOR ADDITIONAL NOTES.
 4. SEE SHEET 2 OF 3 FOR SECTIONS CALLED OUT ON ELEVATION VIEW AND DETAIL "A".
 5. FOR ANCHOR BOLTS, SEE "DISC. BEARING DETAILS" SHEET.

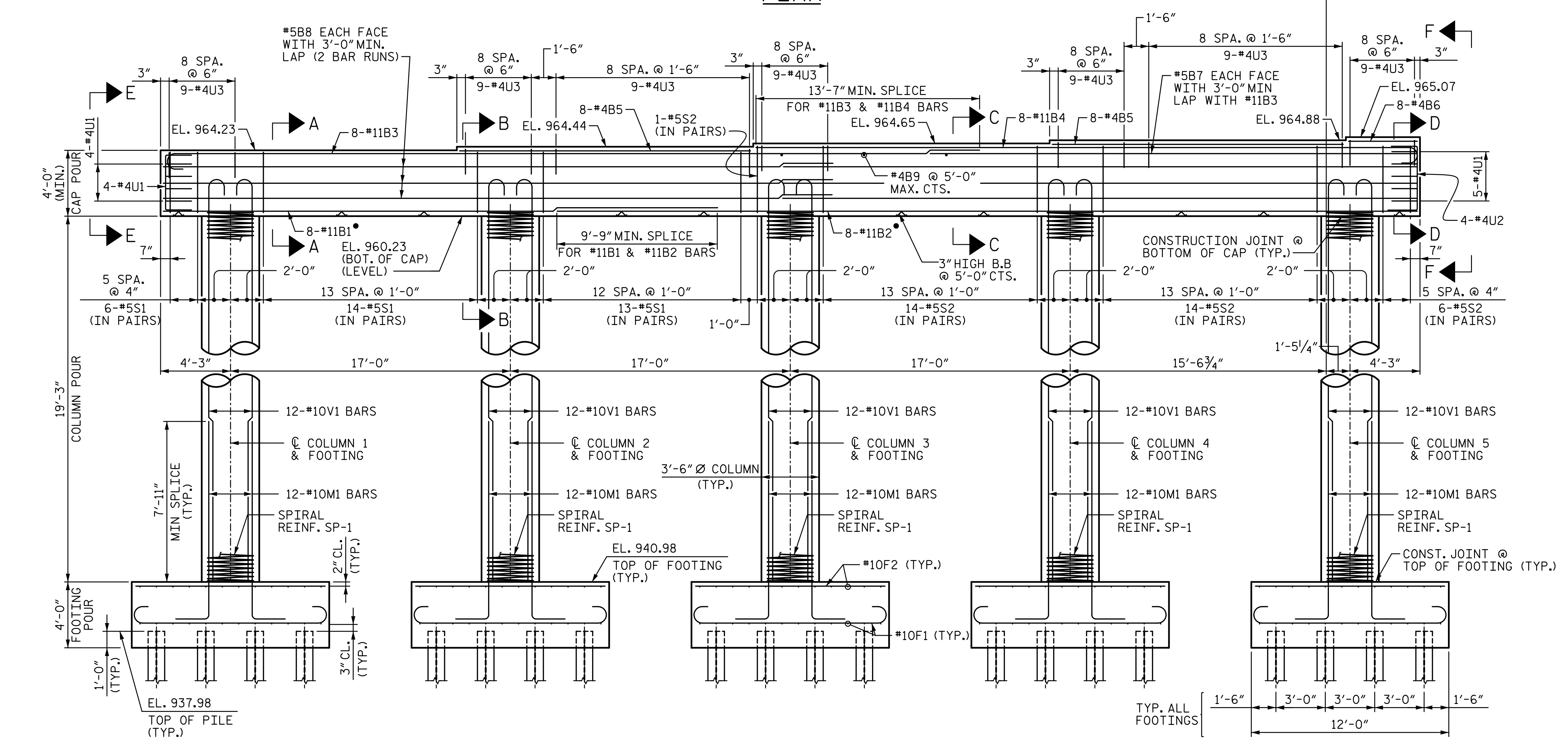

ELEVATION

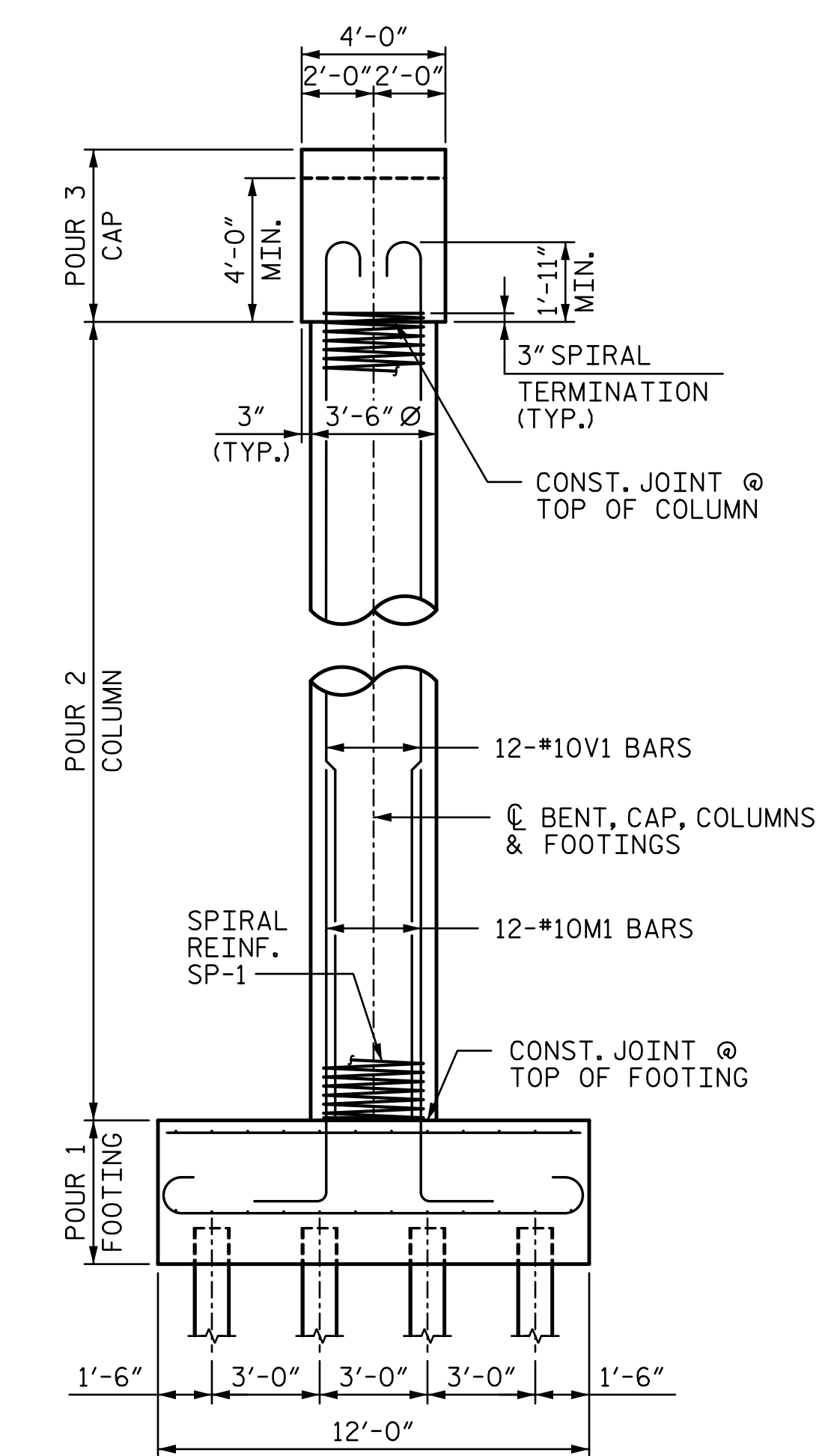

END VIEW

NOTE:
INVERT ALTERNATE PAIRS OF STIRRUPS.

• ALTERNATE ADJACENT B1/B2 BARS

PROJECT NO. R-2707C
CLEVELAND COUNTY
 STATION: 596+50.98 -L-
 SHEET 1 OF 3

DOCUMENT NOT CONSIDERED FINAL UNLESS ALL SIGNATURES COMPLETED		STATE OF NORTH CAROLINA DEPARTMENT OF TRANSPORTATION RALEIGH		SUBSTRUCTURE		BENT 1 PLAN & ELEVATION		(SITE 6L)		SHEET NO. S7-42		
		REVISIONS										TOTAL SHEETS 56
		NO.	BY:	DATE:	NO.	BY:	DATE:					
1			3									
2			4									

12/13/2016 6:59:47 PM R:\407_083_R2707C_SMU_B101_S7-42.dgn
 dveyac

DRAWN BY: <u>ATH</u>	DATE: <u>9-16</u>	DESIGN ENGINEER OF RECORD: <u>V. WU</u>	DATE: <u>10-16</u>
CHECKED BY: <u>TJT</u>	DATE: <u>10-16</u>		