

PROJECT REFERENCE NO. R-2707C	SHEET NO. EC-2B
RW SHEET NO.	
ROADWAY DESIGN ENGINEER	HYDRAULICS ENGINEER

# EARTHEN DAM WITH SKIMMER

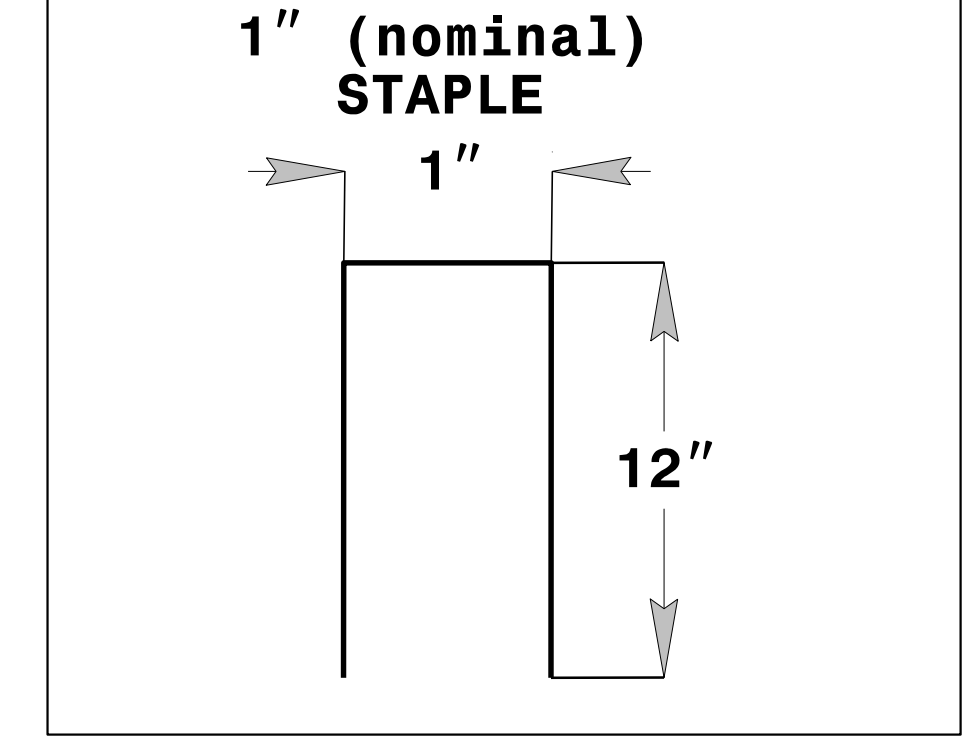
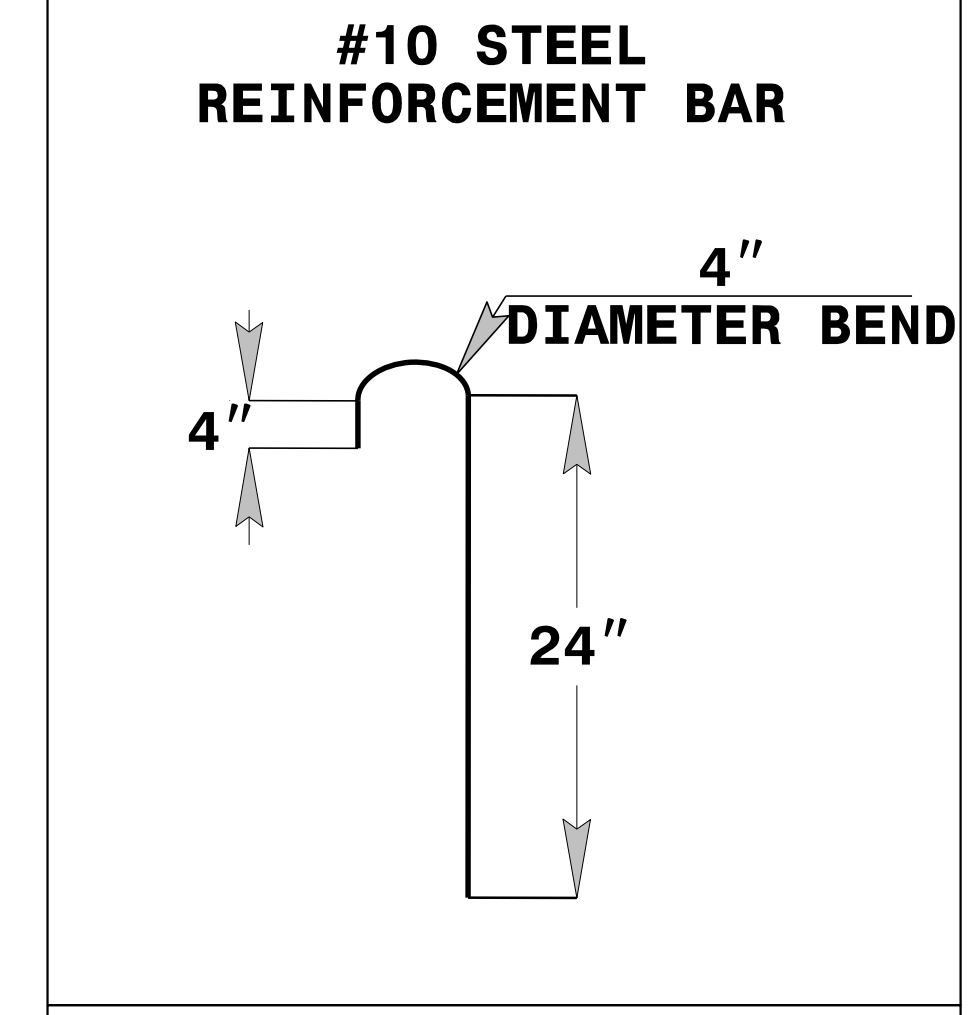
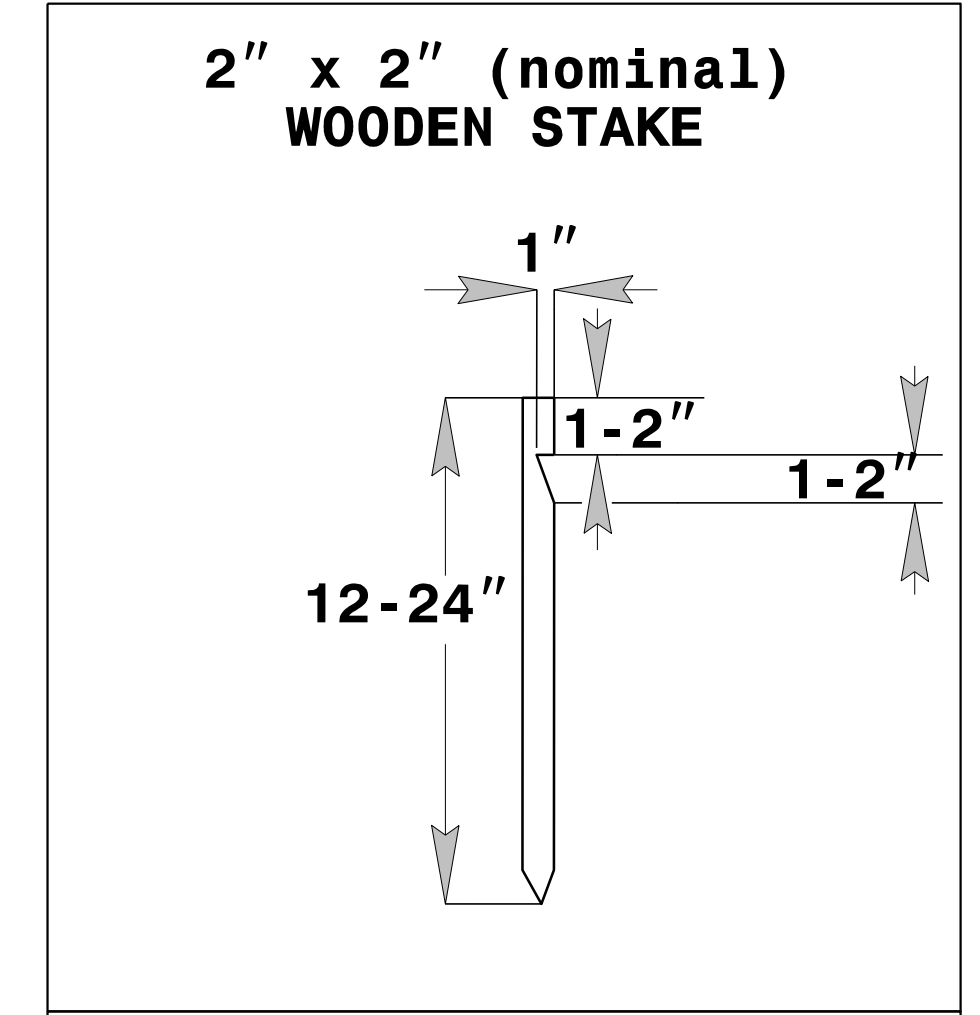
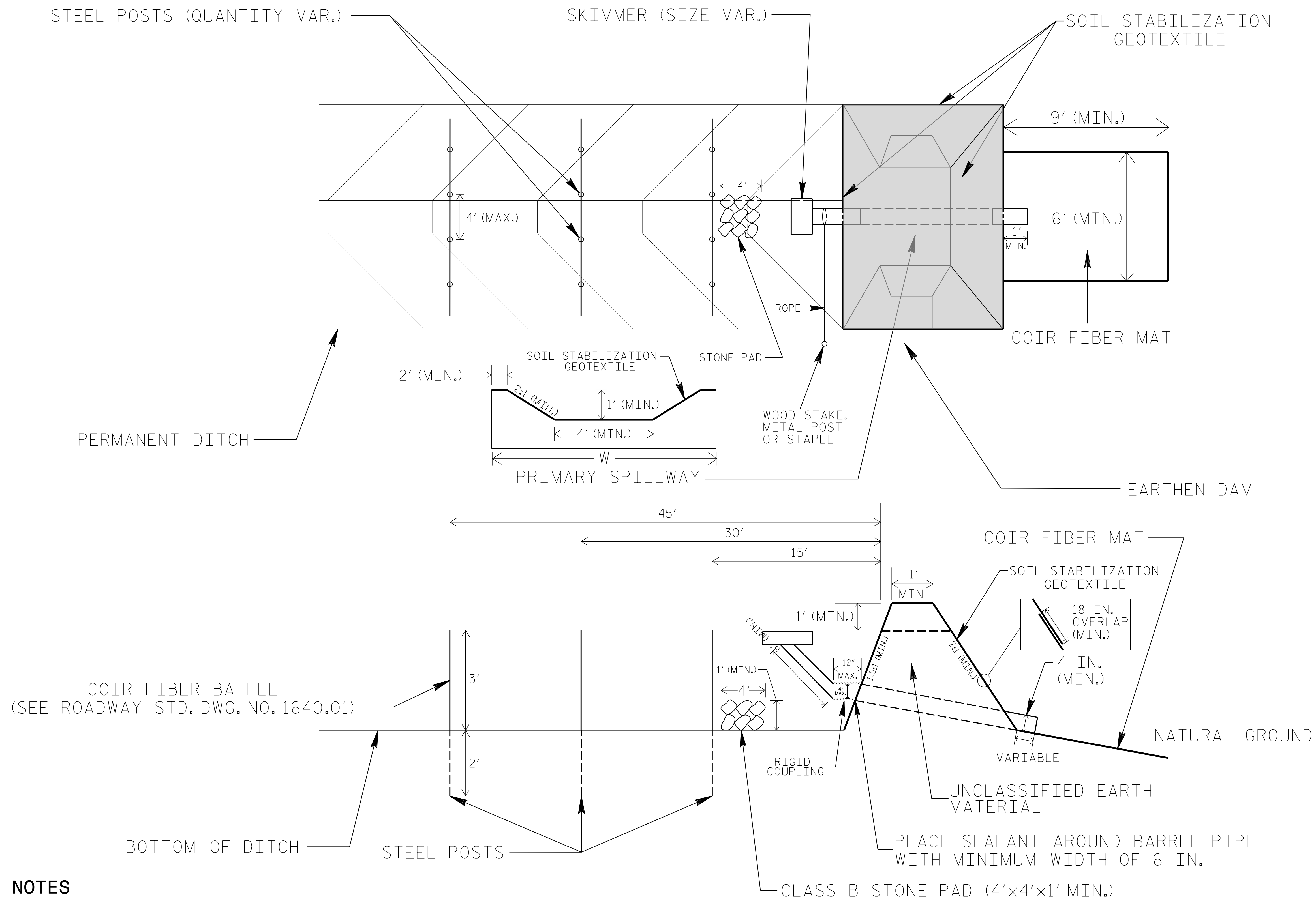

## COIR FIBER MAT ANCHOR OPTIONS

### NOTES

1. LIMIT EARTHEN DAM HEIGHT TO 5 FT.
2. DETERMINE PRIMARY SPILLWAY LENGTH (FT.) USING  $Q/0.8$ , WHERE Q IS FLOW RATE (CFS) INTO BASIN.
3. SOIL STABILIZATION GEOTEXTILE FOR PRIMARY SPILLWAY SHALL BE ONE CONTINUOUS PIECE OF MATERIAL OR OVERLAPPED 18 IN. (MIN.).

NOT TO SCALE