

**DETAIL 13
GRADING DETAIL/BANK STABILIZATION**
SCALE: 1" = 20'

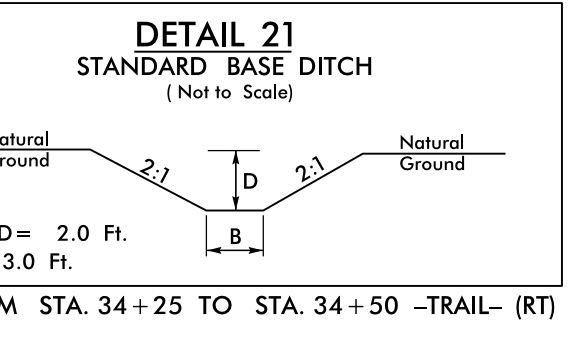
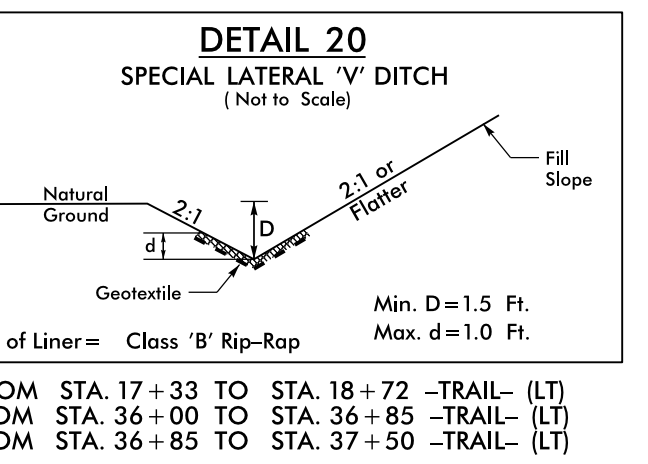
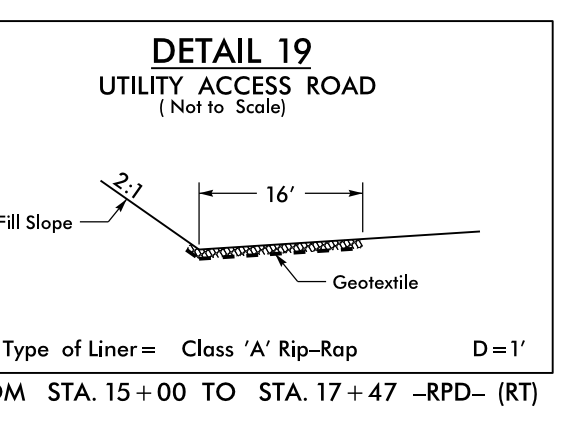
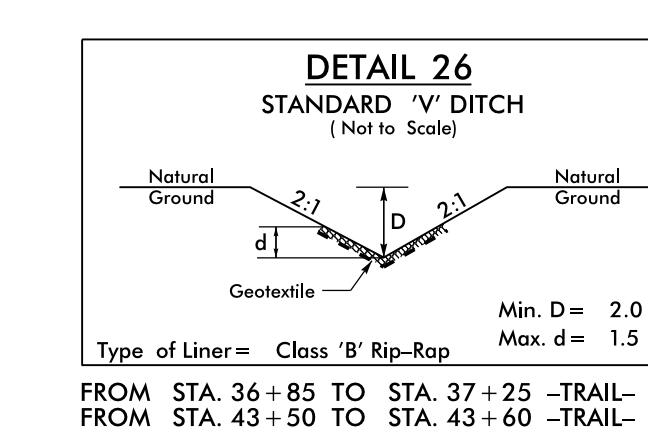
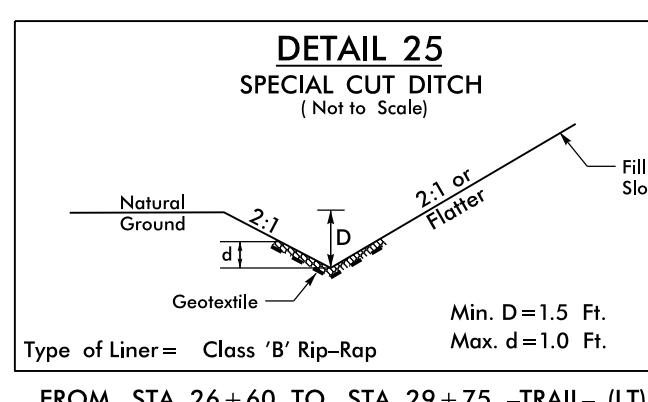
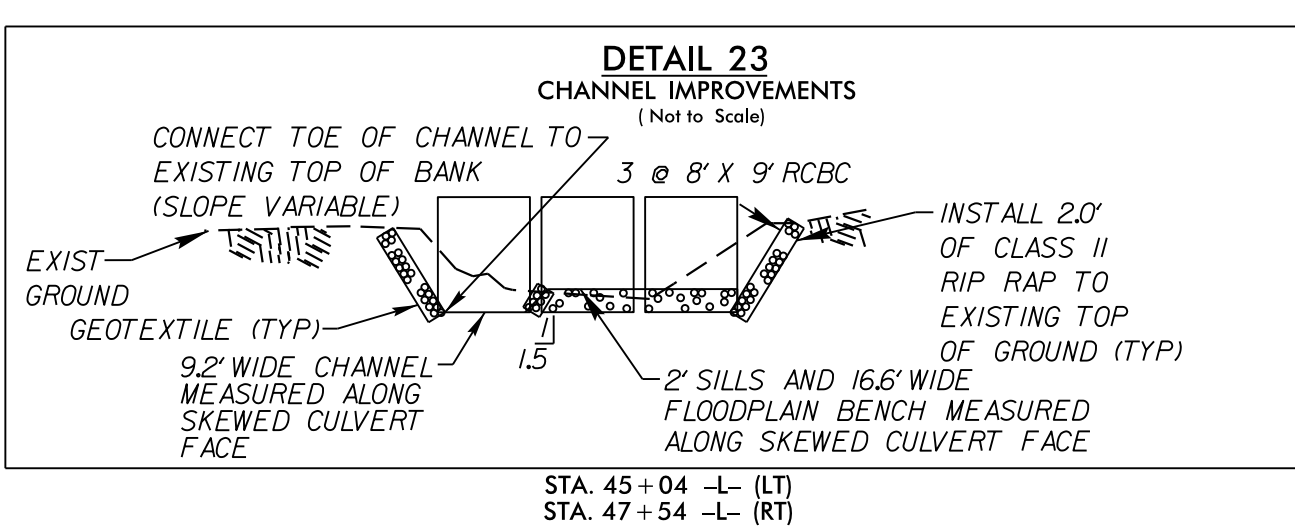
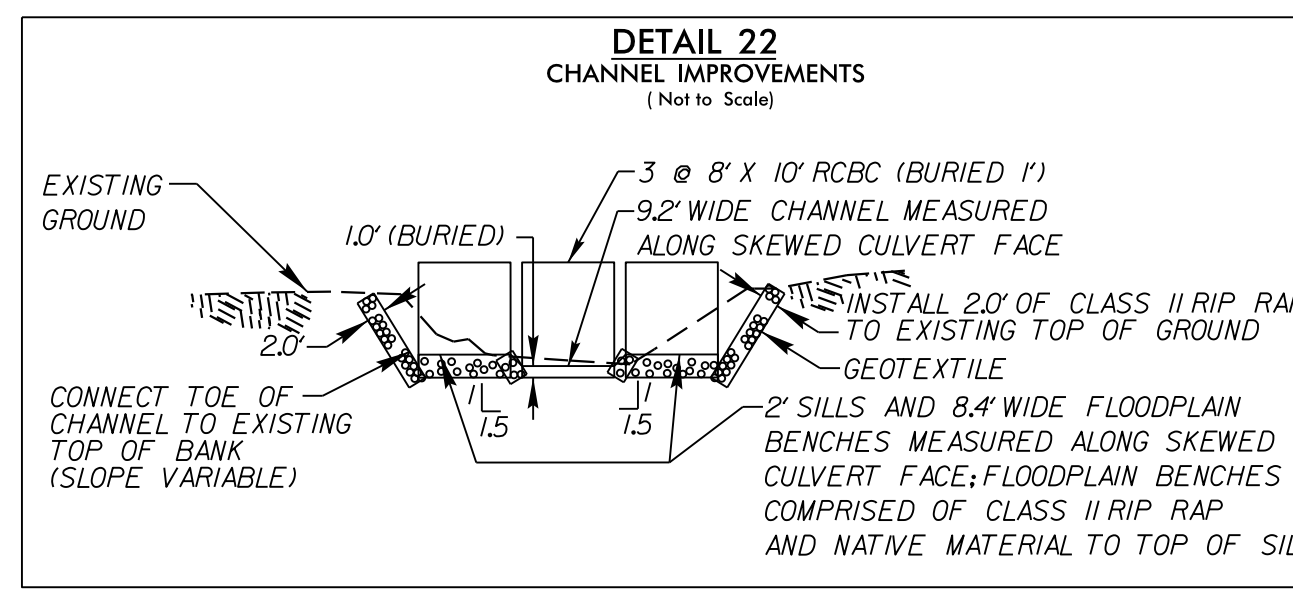
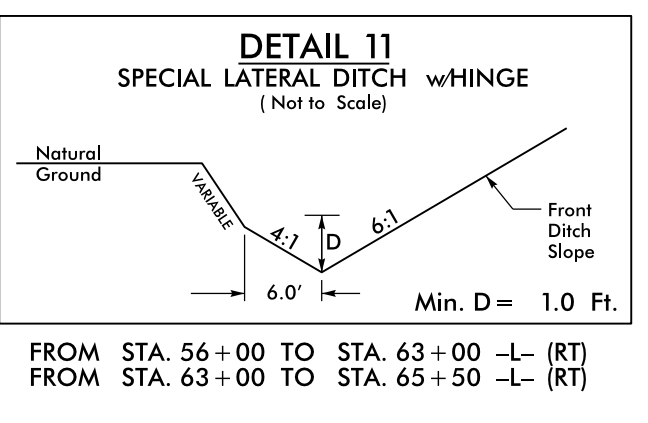
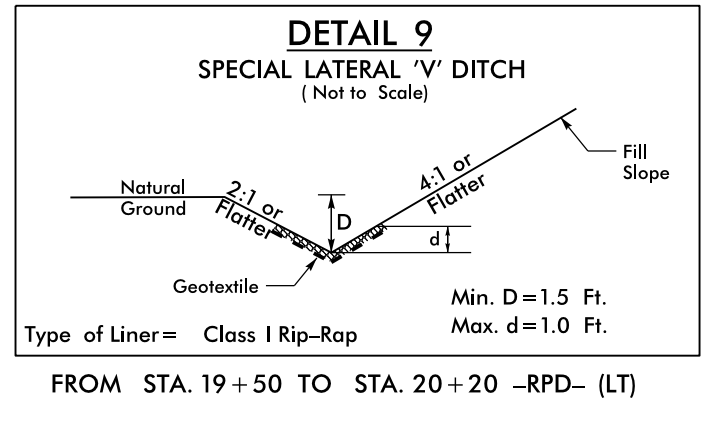
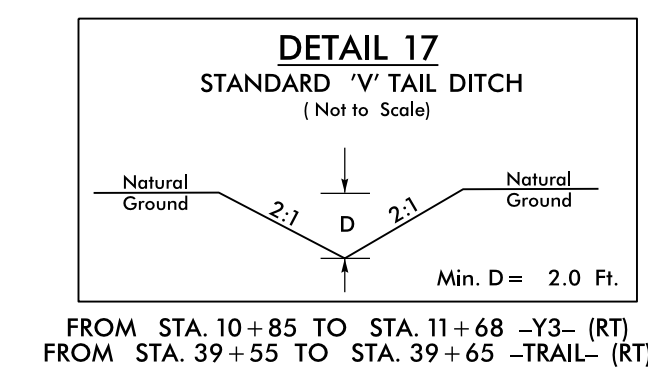
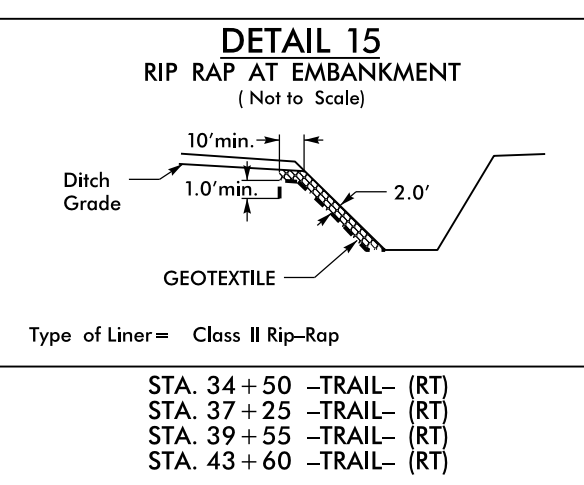
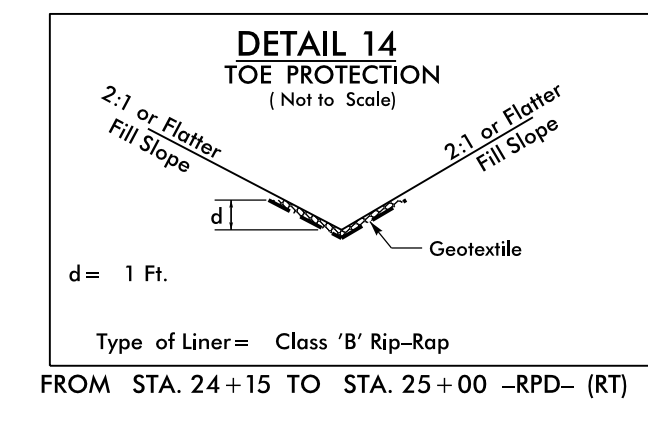
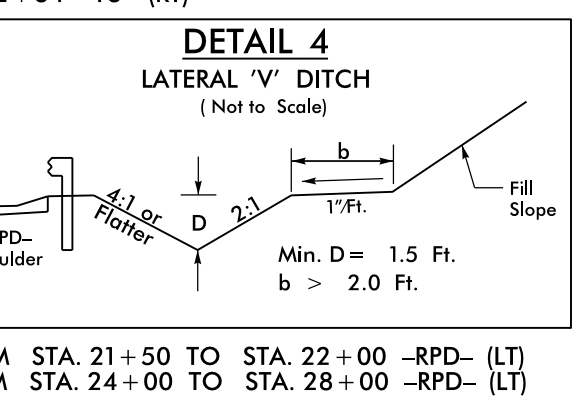
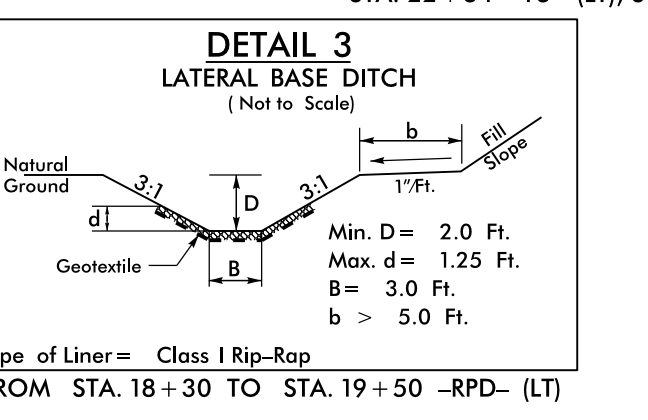
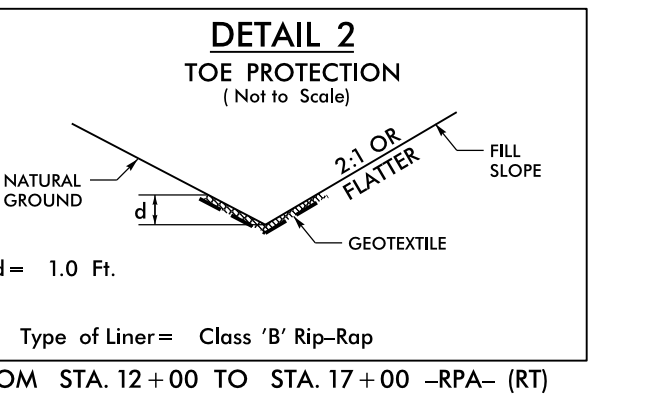
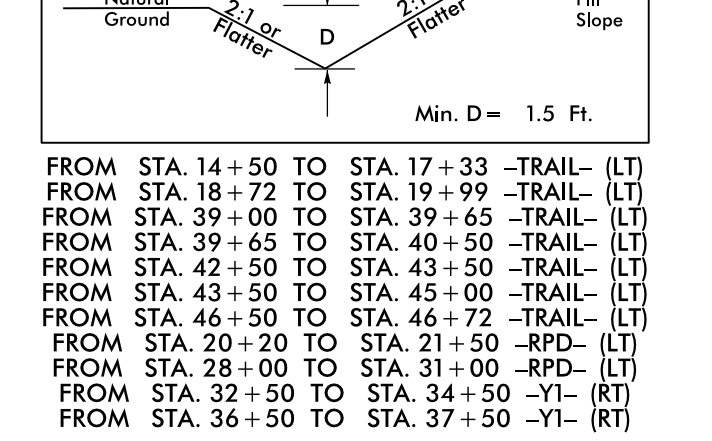
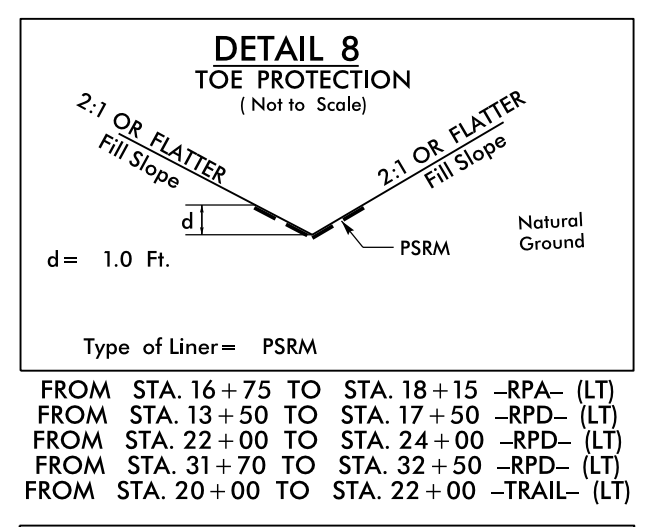
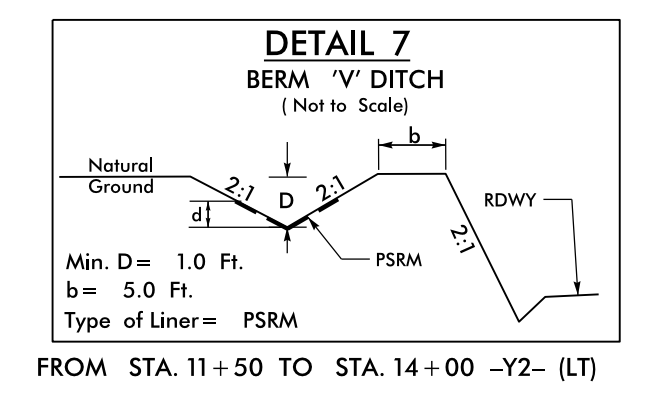
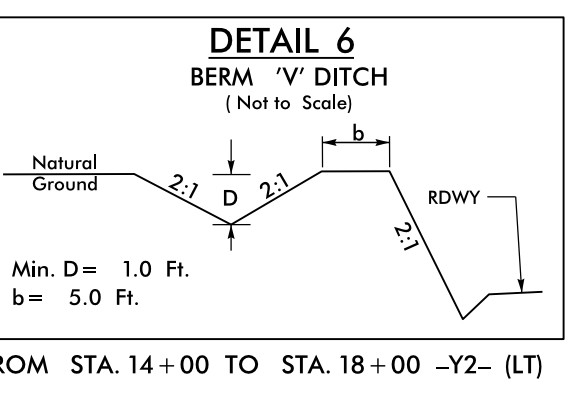
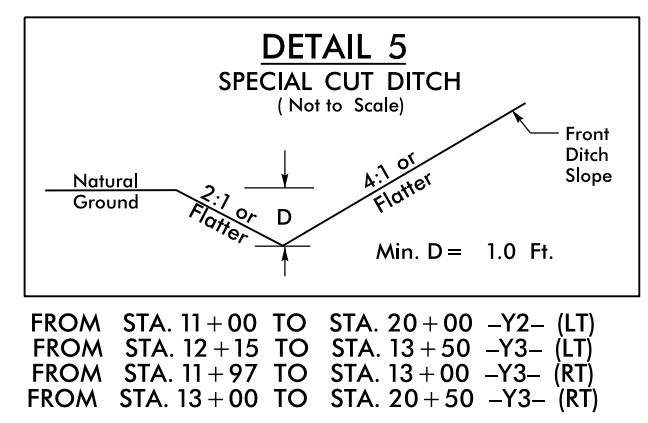
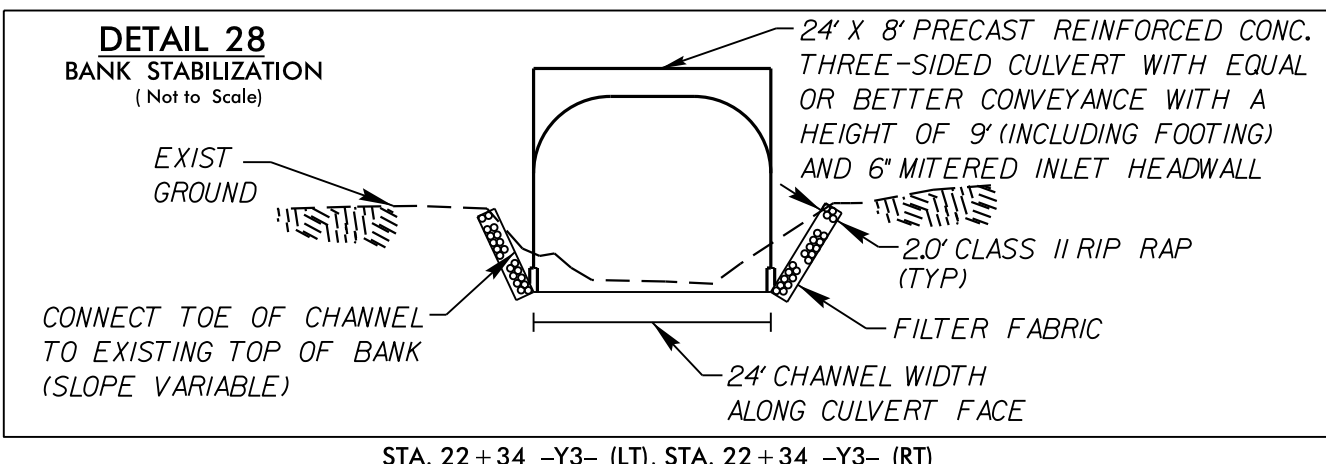
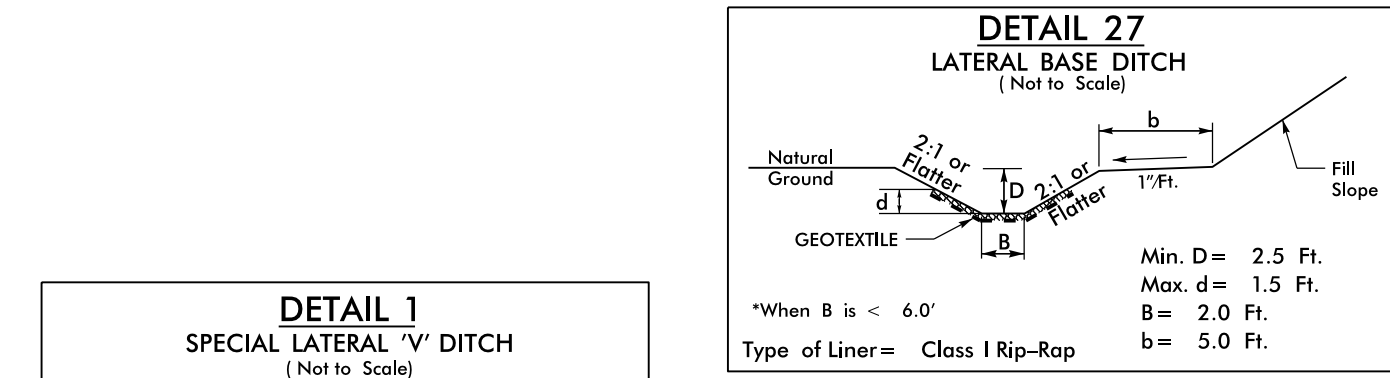
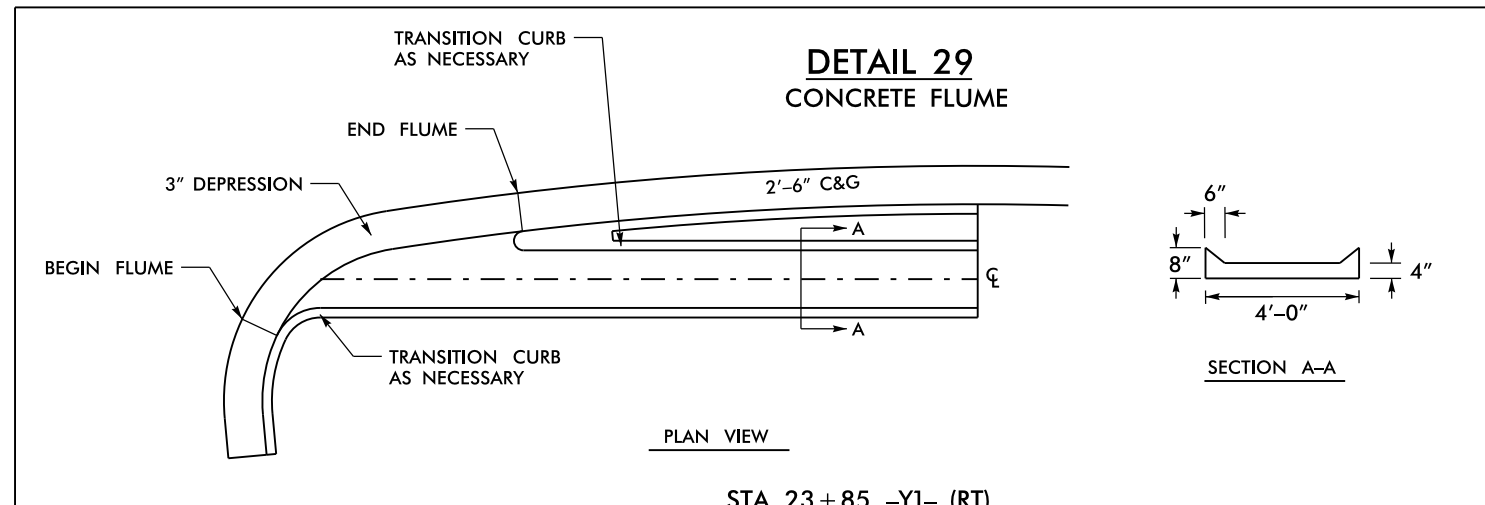
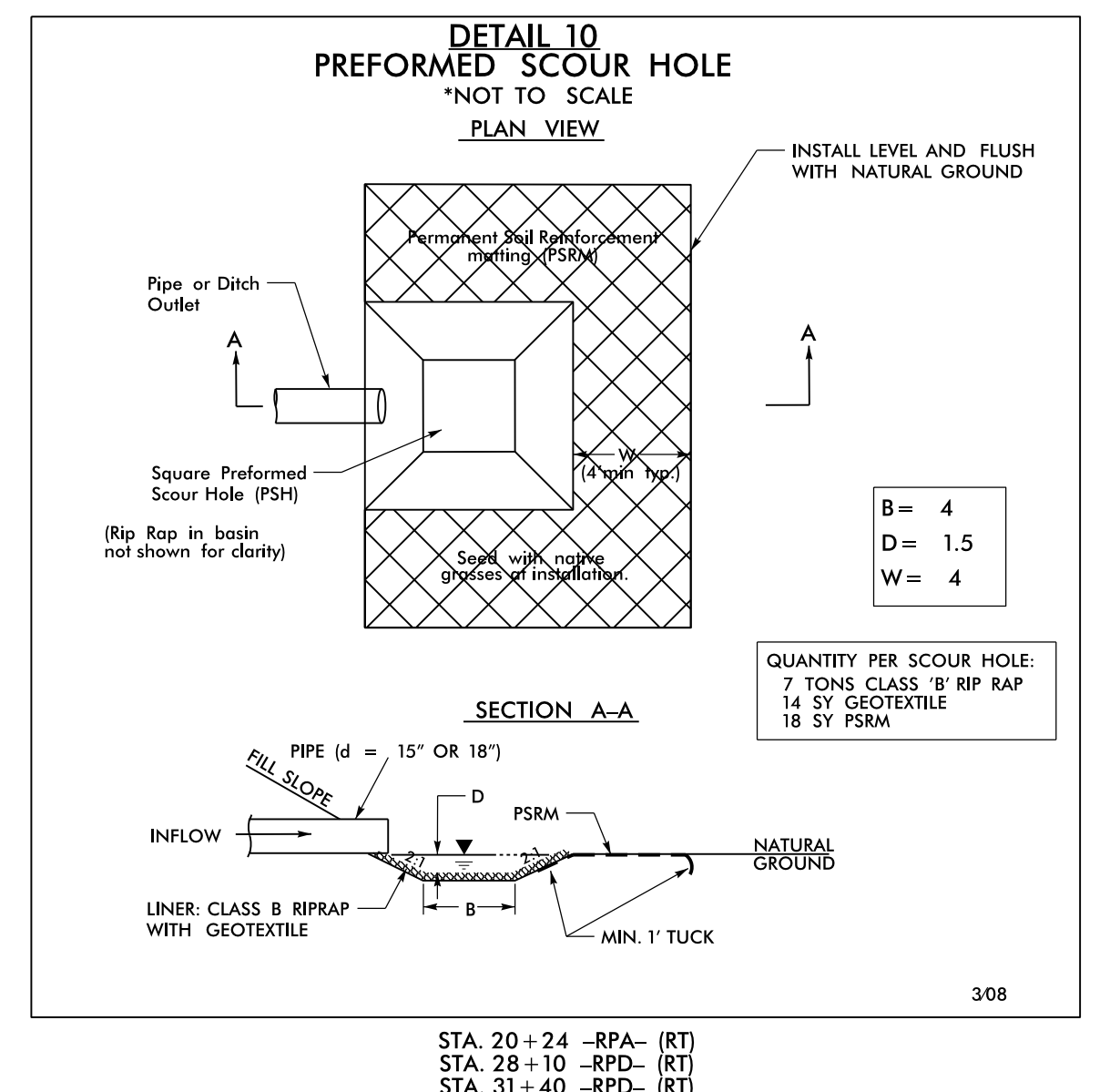
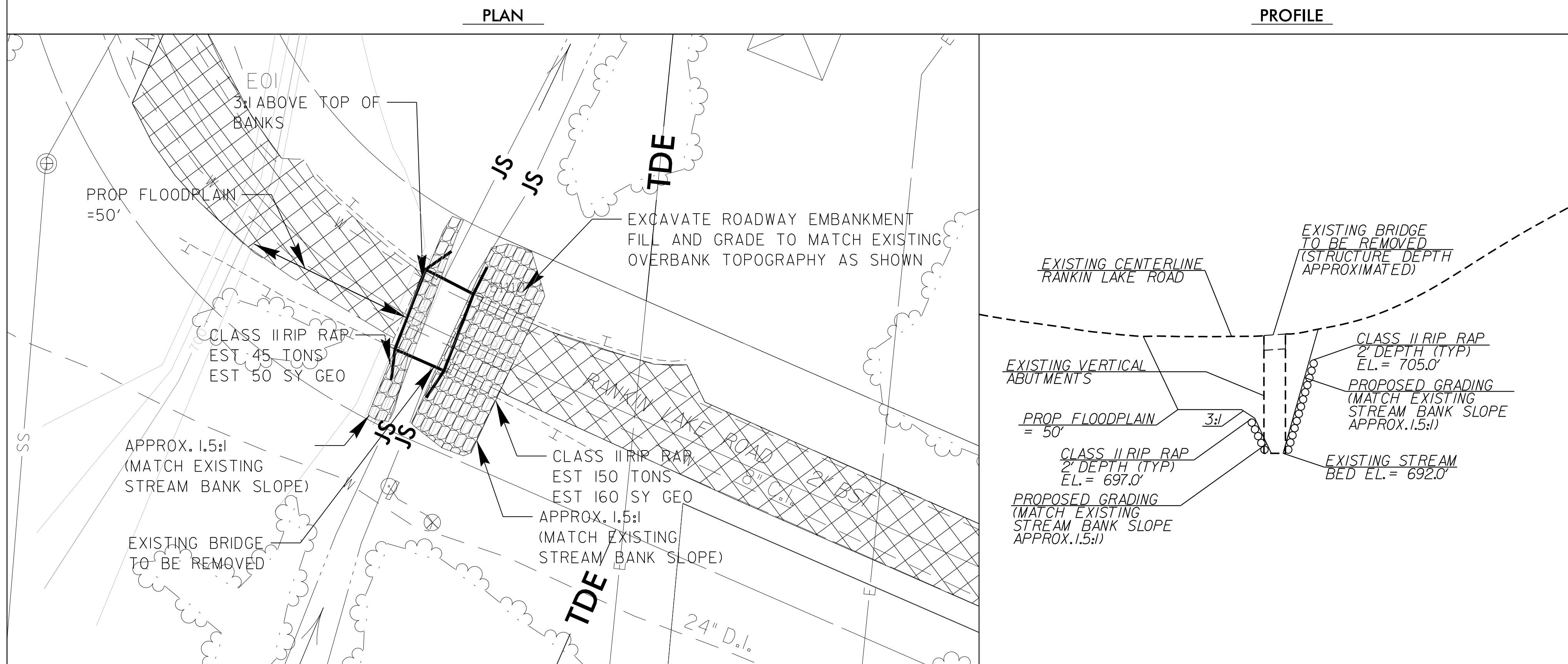

REVISIONS

8/17/99

07-MAR-2017 08:00:00 hyd-detailed.dgn
9:58:45 PM PROJECT: 1-5000