

**This electronic collection of documents is provided
for the convenience of the user
and is Not a Certified Document –**

**The documents contained herein were originally issued
and sealed by the individuals whose names and license
numbers appear on each page, on the dates appearing
with their signature on that page.**

**This file or an individual page
shall not be considered a certified document.**

T.I.P.: R-3100A

CONTRACT NO.: C203800

**STATE OF NORTH CAROLINA
DEPARTMENT OF TRANSPORTATION**

**PAVEMENT MARKING PLAN
CATAWBA COUNTY**

LOCATION: NC 16 FROM NORTH OF SR 1814 (CALDWELL ROAD) TO SR 1895 (TOWER ROAD)

TIP NO. R-3100A	SHEET NO. PMP - 1
Approved by: DATE: 9/21/2016	
DOCUMENT NOT CONSIDERED FINAL UNLESS ALL SIGNATURES COMPLETED	

ROADWAY STANDARD DRAWINGS

THE FOLLOWING ROADWAY STANDARDS AS APPEAR IN "ROADWAY STANDARD DRAWINGS" - PROJECT SERVICES UNIT - N.C. DEPARTMENT OF TRANSPORTATION - RALEIGH, N.C., DATED JANUARY 2012 ARE APPLICABLE TO THIS PROJECT AND BY REFERENCE HEREBY ARE CONSIDERED A PART OF THESE PLANS:

STD. NO.	TITLE
1205.01	PAVEMENT MARKINGS - LINE TYPES & OFFSETS
1205.02	PAVEMENT MARKINGS - 2 LANE & MULTILANE ROADWAYS
1205.04	PAVEMENT MARKINGS - INTERSECTIONS
1205.05	PAVEMENT MARKINGS - TURN LANES
1205.08	PAVEMENT MARKINGS - SYMBOLS & WORD MESSAGES
1205.09	PAVEMENT MARKINGS - PAINTED ISLANDS
1250.01	RAISED PAVEMENT MARKERS - INSTALLATION SPACING
1253.01	RAISED PAVEMENT MARKERS - SNOWPLOWABLE
1261.01	GUARDRAIL & BARRIER DELINEATORS - INSTALLATION SPACING
1261.02	GUARDRAIL & BARRIER DELINEATORS - TYPES & MOUNTING
1262.01	GUARDRAIL END DELINEATION

GENERAL NOTES

THE FOLLOWING GENERAL NOTES APPLY AT ALL TIMES FOR THE DURATION OF THE CONSTRUCTION PROJECT, EXCEPT WHEN OTHERWISE NOTED IN THE PLAN, OR DIRECTED BY THE ENGINEER.

- A) INSTALL PAVEMENT MARKINGS AND PAVEMENT MARKERS ON THE FINAL SURFACE AS FOLLOWS:

ROAD NAME	MARKING	MARKER
ALL ROADS	POLYUREA WITH HIGHLY REFLECTIVE ELEMENTS	SNOWPLOWABLE

- B) TIE PROPOSED PAVEMENT MARKING LINES TO EXISTING PAVEMENT MARKING LINES.
 C) REMOVE/REPLACE ANY CONFLICTING/DAMAGED PAVEMENT MARKINGS AND MARKERS.
 D) PASSING ZONES WILL BE DETERMINED IN THE FIELD AND MUST BE APPROVED BY THE ENGINEER.
 E) STOP BAR LOCATION AT NON-SIGNALIZED INTERSECTIONS MAY BE ADJUSTED AS DIRECTED BY THE ENGINEER.
 F) UNLESS OTHERWISE SPECIFIED, HEATED-IN-PLACE THERMOPLASTIC MAY BE USED IN LIEU OF EXTRUDED THERMOPLASTIC FOR STOP BARS, SYMBOLS, CHARACTERS AND DIAGONALS.

FINAL PAVEMENT MARKING SCHEDULE

SYMBOL	DESCRIPTION	PAY ITEM
T2	WHITE STOPBAR	(24", 120 MIL) THERMOPLASTIC
TA	WHITE EDGELINE	(4", 90 MIL) THERMOPLASTIC
TN	WHITE GORELINE	(8", 90 MIL) THERMOPLASTIC
TU	WHITE DIAGONAL	(12", 90 MIL) THERMOPLASTIC
TV	YELLOW DIAGONAL	(12", 90 MIL) THERMOPLASTIC
UA	LEFT TURN ARROW	(90 MIL) THERMOPLASTIC
UB	RIGHT TURN ARROW	(90 MIL) THERMOPLASTIC
UC	STRAIGHT ARROW	(90 MIL) THERMOPLASTIC
UE	COMBO STRAIGHT/RIGHT	(90 MIL) THERMOPLASTIC
UN	24" YIELD LINE TRIANGLE	(90 MIL) THERMOPLASTIC
UT	U-TURN ARROW	(90 MIL) THERMOPLASTIC
V8	2 FT-6FT/SP WHITE MINISKIP	(4") POLYUREA
V9	2 FT-6FT/SP YELLOW MINISKIP	(4") POLYUREA
VA	WHITE EDGELINE	(4") POLYUREA
VB	YELLOW EDGELINE	(4") POLYUREA
VC	10 FT WHITE SKIP	(4") POLYUREA
VD	3 FT-9 FT/SP WHITE MINISKIP	(4") POLYUREA
VE	WHITE SOLID LANE LINE	(4") POLYUREA
VI	YELLOW DOUBLE CENTER	(4") POLYUREA
VN	WHITE GORELINE	(8") POLYUREA

PLAN REVIEWED BY: N.C.D.O.T. SIGNING AND DELINEATION UNIT

KELVIN JORDAN SIGNING & DELINEATION REGIONAL ENGINEER

DERRICK BEARD SIGNING & DELINEATION PROJECT DESIGN ENGINEER

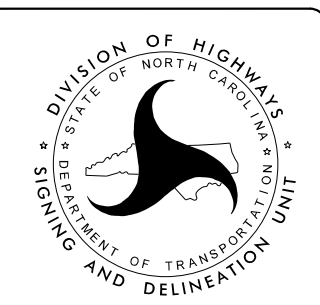

PLAN PREPARED BY:

BETSY L. WATSON, P.E. TRAFFIC ENGINEER



ROSI R. HENNEIN TRANSPORTATION DESIGNER



Stantec Consulting Services Inc.
801 Jones Franklin Road
Suite 300
Raleigh, NC 27606
Tel. (919) 851-6866
Fax. (919) 851-7024
www.stantec.com
License No. F-6672

INDEX

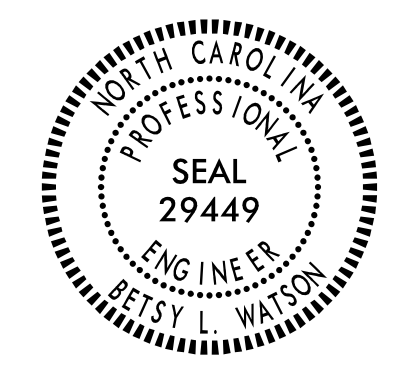
SHEET NO.	DESCRIPTION
PMP - 1	PAVEMENT MARKING PLAN TITLE AND SCHEDULE SHEET
PMP - 2 - 17	PAVEMENT MARKING DETAIL

TIP NO. R-3100A	SHEET NO. PMP-2
APPROVED: <i>Betsy L. Watson</i> <small>DocuSigned by: Betsy L. Watson 35E678B34F8743F...</small>	
DATE: 9/5/2016	
SEAL	
	
DOCUMENT NOT CONSIDERED FINAL UNLESS ALL SIGNATURES COMPLETED	
	

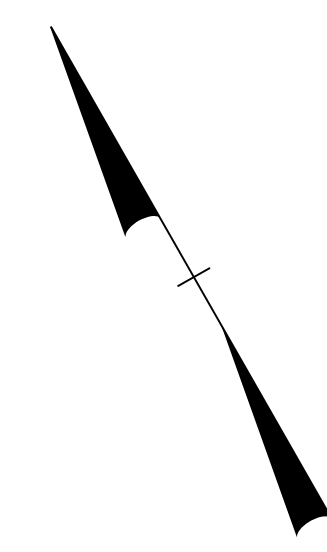

BEGIN R-3100A PAVEMENT MARKING PLAN
END R-3100B -L- STA 12+00

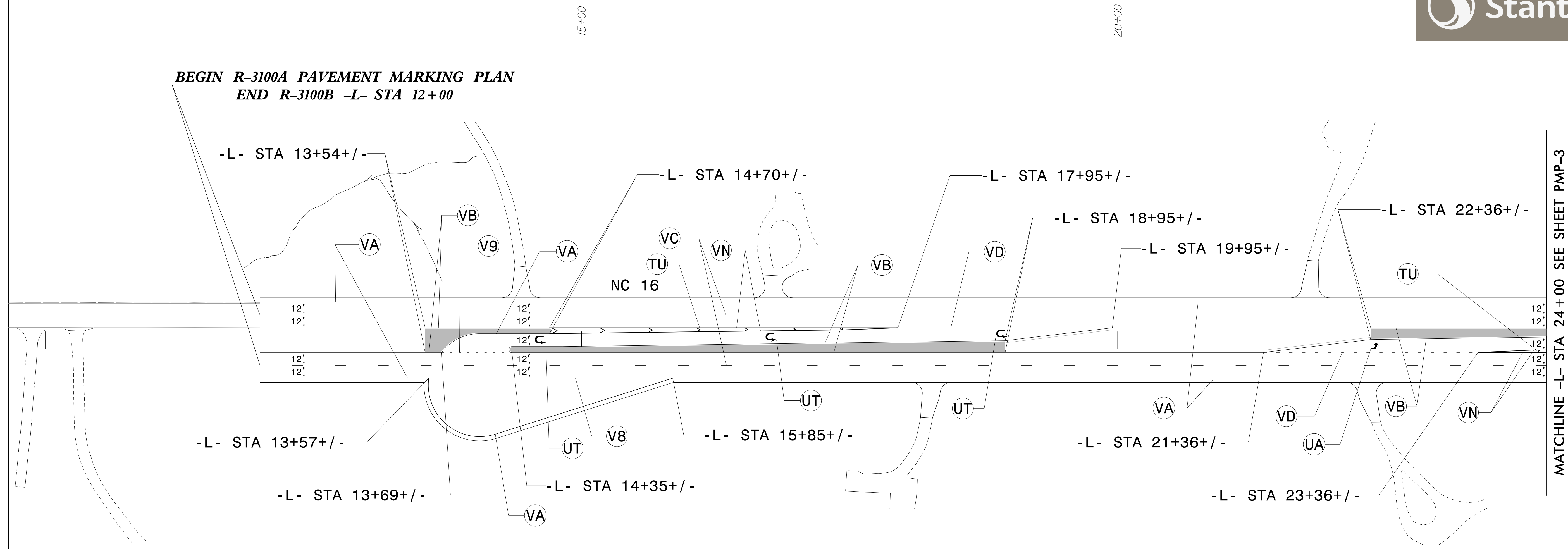



LEFT TURN ARROW	WHITE DIAGONAL (12")
U-TURN ARROW	

2 FT - 6 FT/SP WHITE MINISKIP (4")
2 FT - 6 FT/SP YELLOW MINISKIP (4")
WHITE EDGELINE (4")
YELLOW EDGELINE (4")
10 FT WHITE SKIP (4")
3 FT - 9 FT/SP WHITE MINISKIP (4")
WHITE GORELINE (8")

PAVEMENT MARKING DETAIL

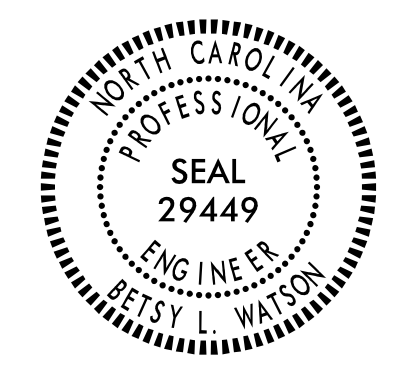
\$\$\$SYTIME\$\$\$\$
 \$\$\$DGN\$\$\$\$
 \$\$\$USERNAME\$\$\$\$

TIP NO. R-3100A	SHEET NO. PMP-3
APPROVED: <i>Betsy L. Watson</i> DocuSigned by: 35E07B834F8743F...	
DATE: 9/5/2016	
SEAL	
	
DOCUMENT NOT CONSIDERED FINAL UNLESS ALL SIGNATURES COMPLETED	
	

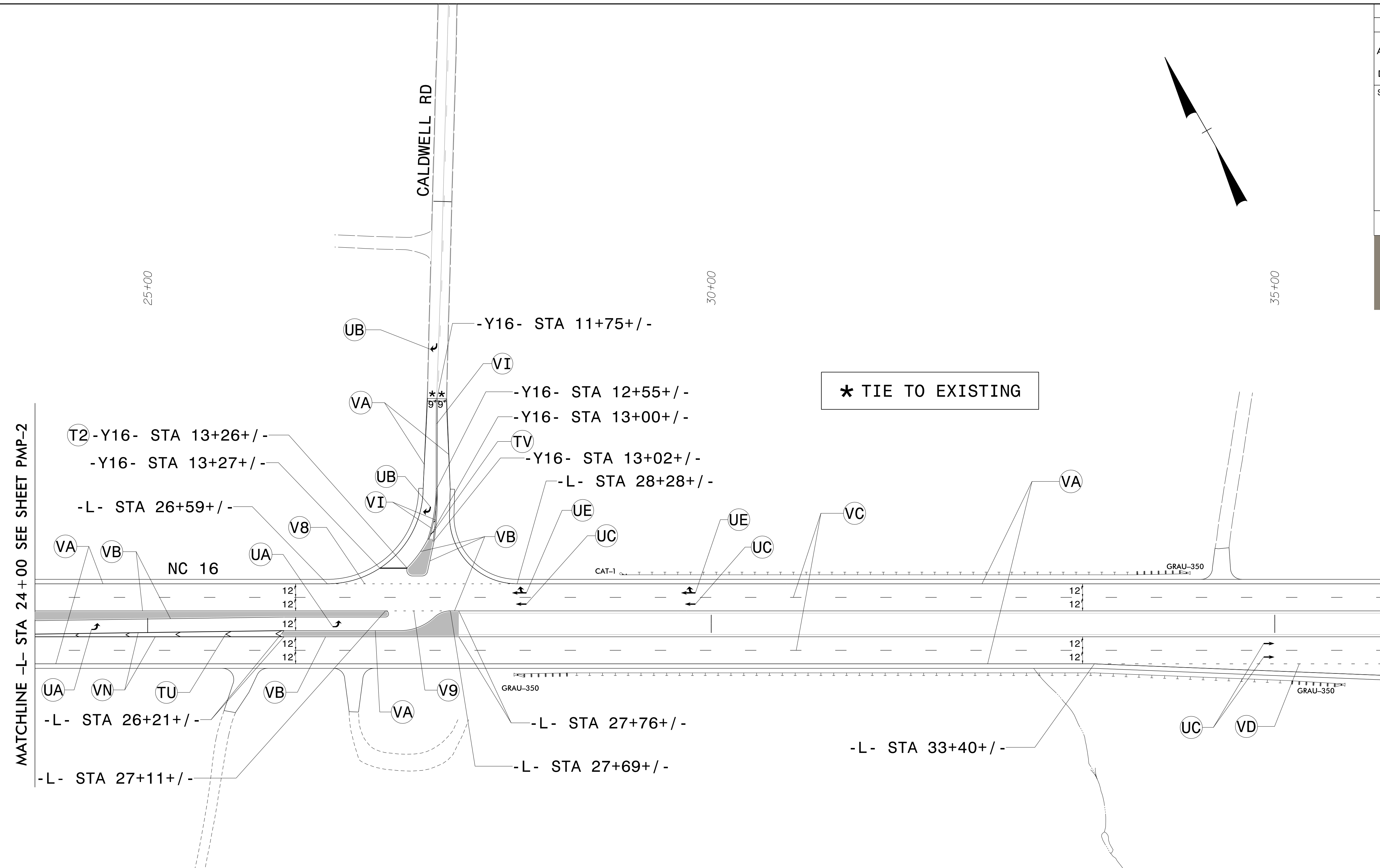



(UA) LEFT TURN ARROW	(T2) WHITE STOPBAR (24")
(UB) RIGHT TURN ARROW	(TU) WHITE DIAGONAL (12")
(UC) STRAIGHT ARROW	(TV) YELLOW DIAGONAL (12")
(UE) COMBO STRAIGHT/RIGHT	

(V8) 2 FT - 6 FT/SP WHITE MINISKIP (4")
(V9) 2 FT - 6 FT/SP YELLOW MINISKIP (4")
(VA) WHITE EDGELINE (4")
(VB) YELLOW EDGELINE (4")
(VC) 10 FT WHITE SKIP (4")
(VD) 3 FT - 9 FT/SP WHITE MINISKIP (4")
(VI) YELLOW DOUBLE CENTER (4")
(VN) WHITE GORELINE (8")

\$\$\$\$\$SYTIME\$\$\$\$\$
 \$\$\$DDGN\$\$\$\$\$
 \$\$\$USERNAME\$\$\$\$\$

PAVEMENT MARKING DETAIL

TIP NO. R-3100A	SHEET NO. PMP-4
APPROVED: <i>Betsy L. Watson</i> <small>DocuSigned by: Betsy L. Watson 35E67B34F8743F...</small>	
DATE: 9/5/2016	
SEAL 	
DOCUMENT NOT CONSIDERED FINAL UNLESS ALL SIGNATURES COMPLETED	
	

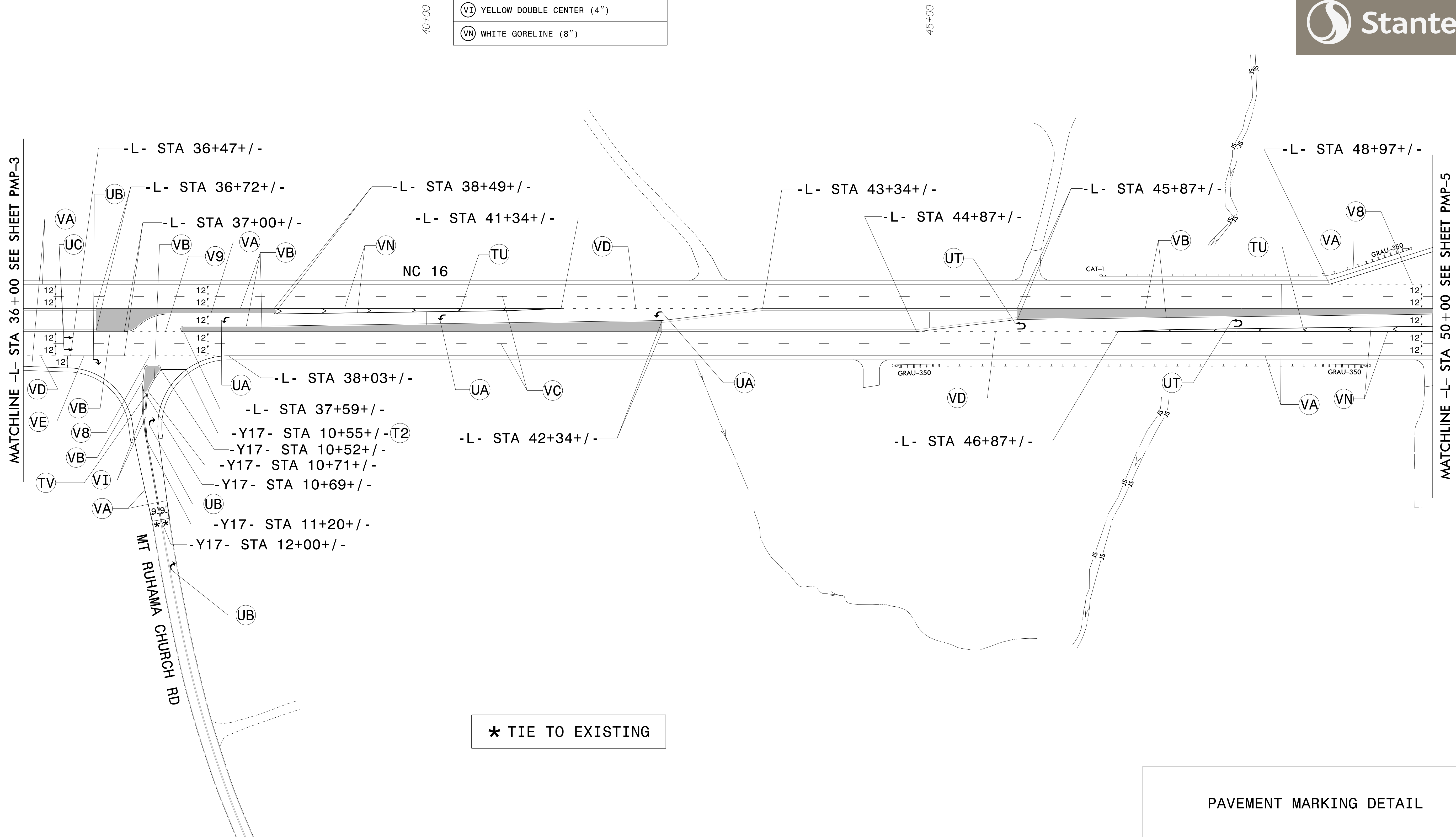
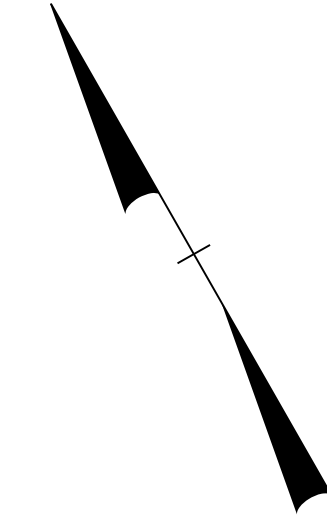

UA	← LEFT TURN ARROW	T2	WHITE STOPBAR (24")
UB	→ RIGHT TURN ARROW	TU	WHITE DIAGONAL (12")
UC	↑ STRAIGHT ARROW	TV	YELLOW DIAGONAL (12")
UT	↻ U-TURN ARROW		

V8	2 FT - 6 FT/SP WHITE MINISKIP (4")
V9	2 FT - 6 FT/SP YELLOW MINISKIP (4")
VA	WHITE EDGELINE (4")
VB	YELLOW EDGELINE (4")
VC	10 FT WHITE SKIP (4")
VD	3 FT - 9 FT/SP WHITE MINISKIP (4")
VE	WHITE SOLID LANE LINE (4")
VI	YELLOW DOUBLE CENTER (4")
VN	WHITE GORELINE (8")

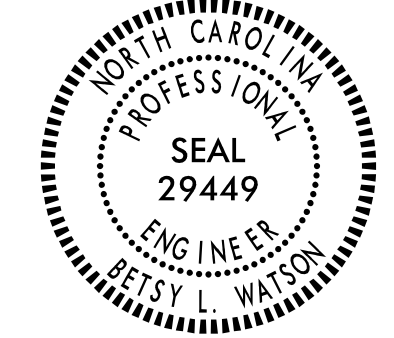

\$\$\$\$\$SYTIME\$\$\$\$\$
 \$\$\$DDGN\$\$\$\$\$
 \$\$\$USERNAME\$\$\$\$\$

PAVEMENT MARKING DETAIL

TIP NO. R-3100A	SHEET NO. PMP-5
APPROVED: <i>Betsy L. Watson</i> SEAL 29449 DATE: 9/5/2016	
SEAL 	
DOCUMENT NOT CONSIDERED FINAL UNLESS ALL SIGNATURES COMPLETED	
	

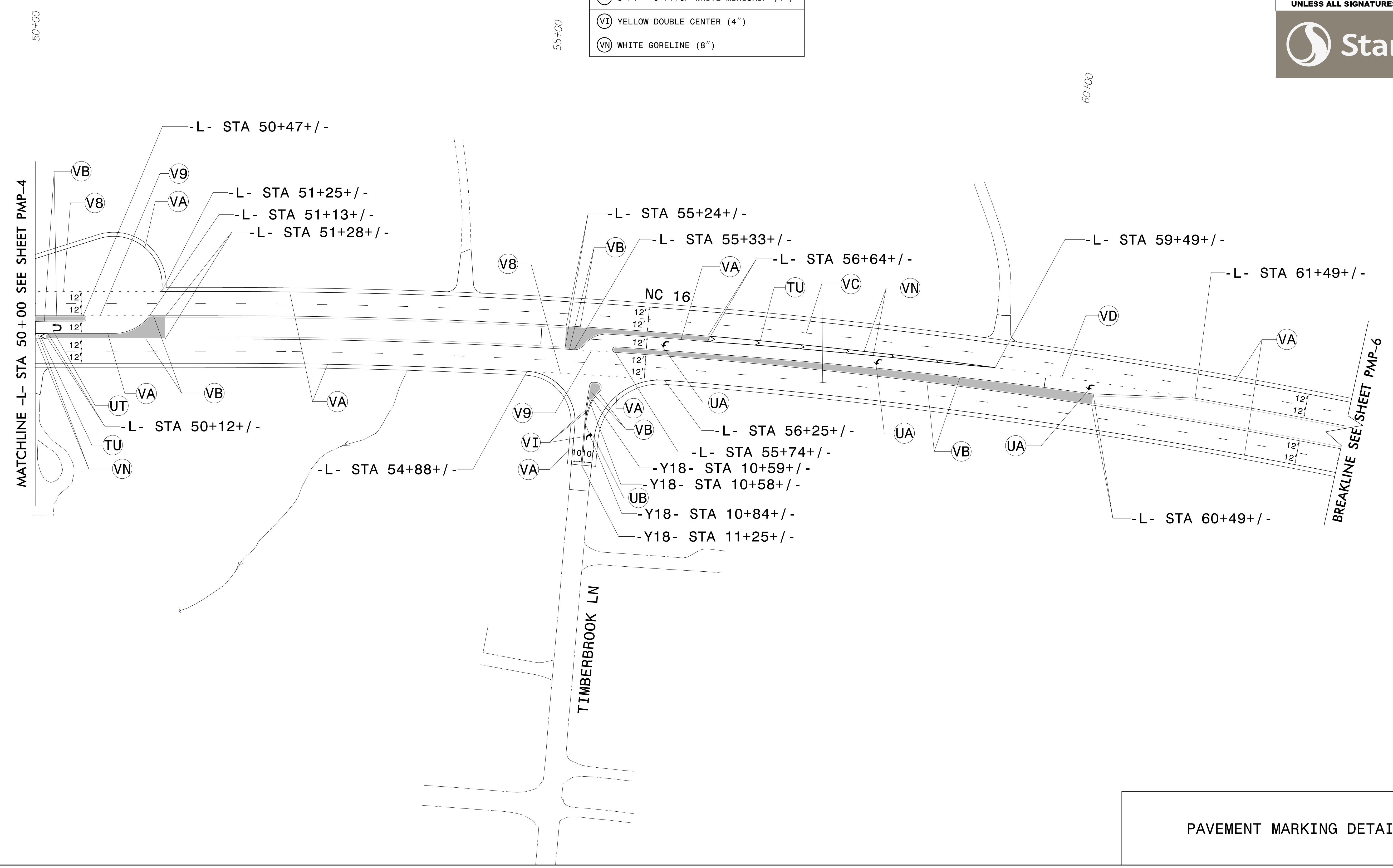

THERMOPLASTIC PAVEMENT MARKING LEGEND	
UA	LEFT TURN ARROW
UB	RIGHT TURN ARROW
UT	U-TURN ARROW
TU	WHITE DIAGONAL (12")

POLYUREA PAVEMENT MARKING LEGEND	
V8	2 FT - 6 FT/SP WHITE MINISKIP (4")
V9	2 FT - 6 FT/SP YELLOW MINISKIP (4")
VA	WHITE EDGELINE (4")
VB	YELLOW EDGELINE (4")
VC	10 FT WHITE SKIP (4")
VD	3 FT - 9 FT/SP WHITE MINISKIP (4")
VI	YELLOW DOUBLE CENTER (4")
VN	WHITE GORELINE (8")



\$\$\$\$\$SYTIME\$\$\$\$\$
 \$\$\$DDGN\$\$\$\$\$
 \$\$\$USERNAME\$\$\$\$\$

PAVEMENT MARKING DETAIL

TIP NO. R-3100A	SHEET NO. PMP-6
APPROVED: <i>Betsy L. Watson</i> <small>DocuSigned by: Betsy L. Watson 355E78B34F8743F</small>	
DATE: 9/5/2016	
SEAL	
	
DOCUMENT NOT CONSIDERED FINAL UNLESS ALL SIGNATURES COMPLETED	
	

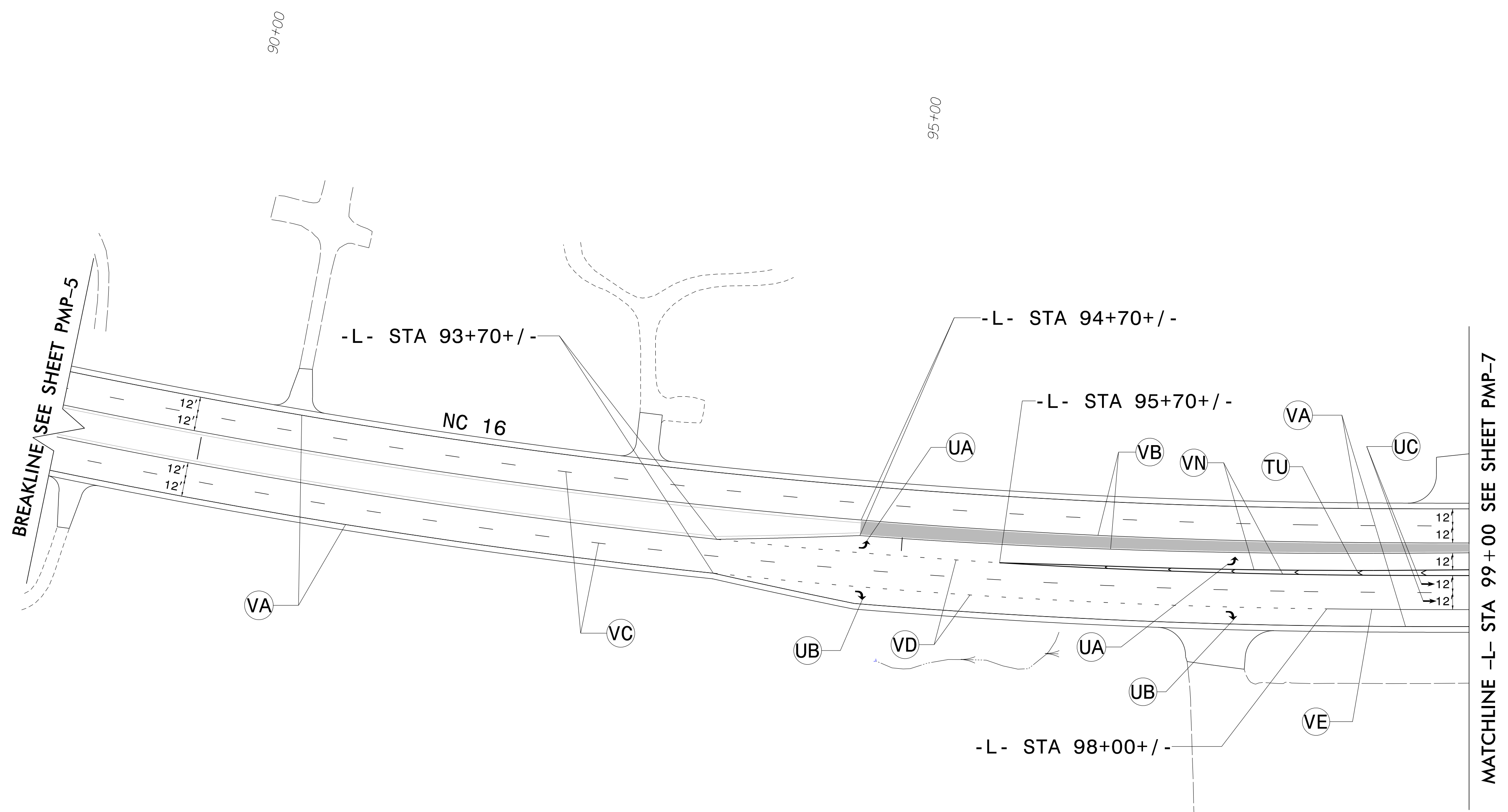
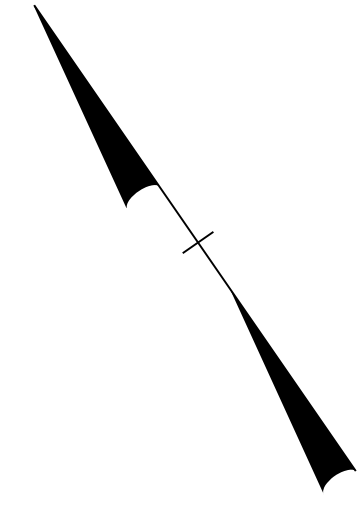

THERMOPLASTIC PAVEMENT MARKING LEGEND	
(UA) ← LEFT TURN ARROW	(TU) WHITE DIAGONAL (12")
(UB) ↘ RIGHT TURN ARROW	
(UC) ↑ STRAIGHT ARROW	

POLYUREA PAVEMENT MARKING LEGEND	
(VA) WHITE EDGELINE (4")	
(VB) YELLOW EDGELINE (4")	
(VC) 10 FT WHITE SKIP (4")	
(VD) 3 FT - 9 FT/SP WHITE MINISKIP (4")	
(VE) WHITE SOLID LANE LINE (4")	
(VN) WHITE GORELINE (8")	

\$\$\$\$\$SYTIME\$\$\$\$\$
 \$\$\$DGN\$\$\$\$\$
 \$\$\$USERNAME\$\$\$\$\$

PAVEMENT MARKING DETAIL

APPROVED: *Betsy L. Watson*
DocuSigned by:
 Betsy L. Watson
 35E978B34F8743F

DATE: 9/5/2016

SEAL

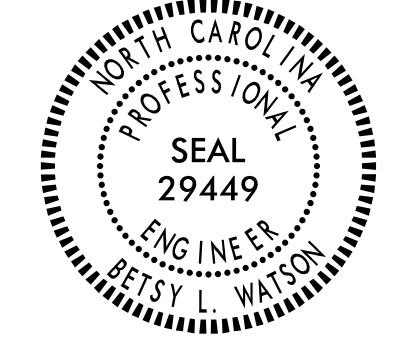

DOCUMENT NOT CONSIDERED FINAL
 UNLESS ALL SIGNATURES COMPLETED

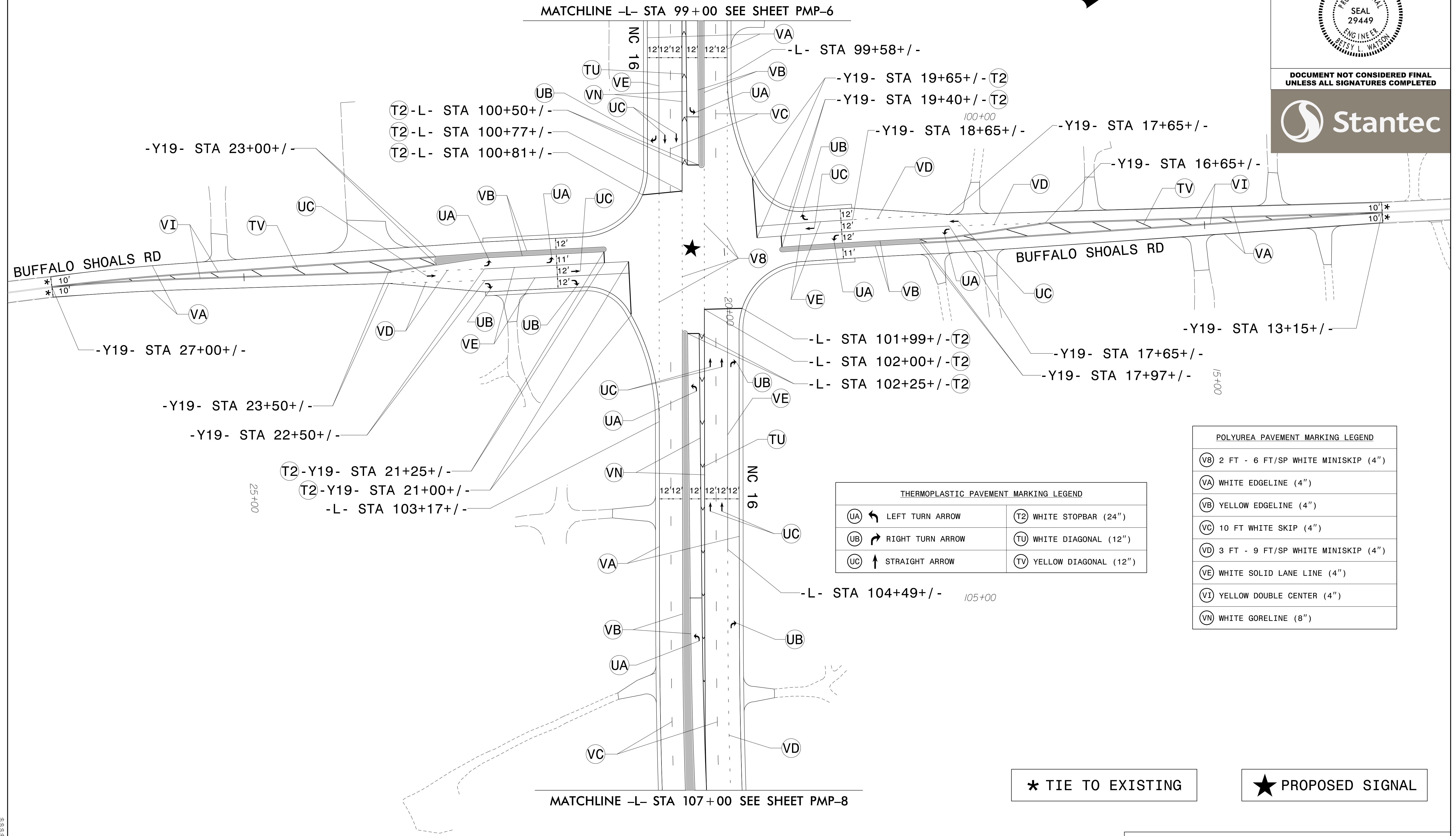
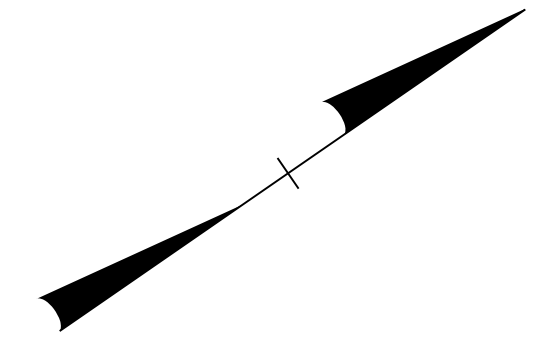

THERMOPLASTIC PAVEMENT MARKING LEGEND			
UA	LEFT TURN ARROW	T2	WHITE STOPBAR (24")
UB	RIGHT TURN ARROW	TU	WHITE DIAGONAL (12")
UC	STRAIGHT ARROW	TV	YELLOW DIAGONAL (12")



POLYUREA PAVEMENT MARKING LEGEND	
V8	2 FT - 6 FT/SP WHITE MINISKIP (4")
VA	WHITE EDGELINE (4")
VB	YELLOW EDGELINE (4")
VC	10 FT WHITE SKIP (4")
VD	3 FT - 9 FT/SP WHITE MINISKIP (4")
VE	WHITE SOLID LANE LINE (4")
VI	YELLOW DOUBLE CENTER (4")
VN	WHITE GORELINE (8")

* TIE TO EXISTING

★ PROPOSED SIGNAL

PAVEMENT MARKING DETAIL

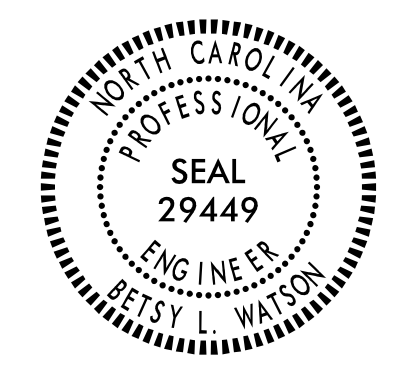
\$\$\$\$\$SYTIME\$\$\$\$\$
 \$\$\$DDGN\$\$\$\$\$
 \$\$\$USERNAME\$\$\$\$\$

TIP NO. R-3100A	SHEET NO. PMP-8
APPROVED: <i>Ebony L. Watson</i> <small>DocuSigned by: Ebony L. Watson 35E67B834F8743F...</small>	
DATE: 9/5/2016	
SEAL	
	
DOCUMENT NOT CONSIDERED FINAL UNLESS ALL SIGNATURES COMPLETED	
	

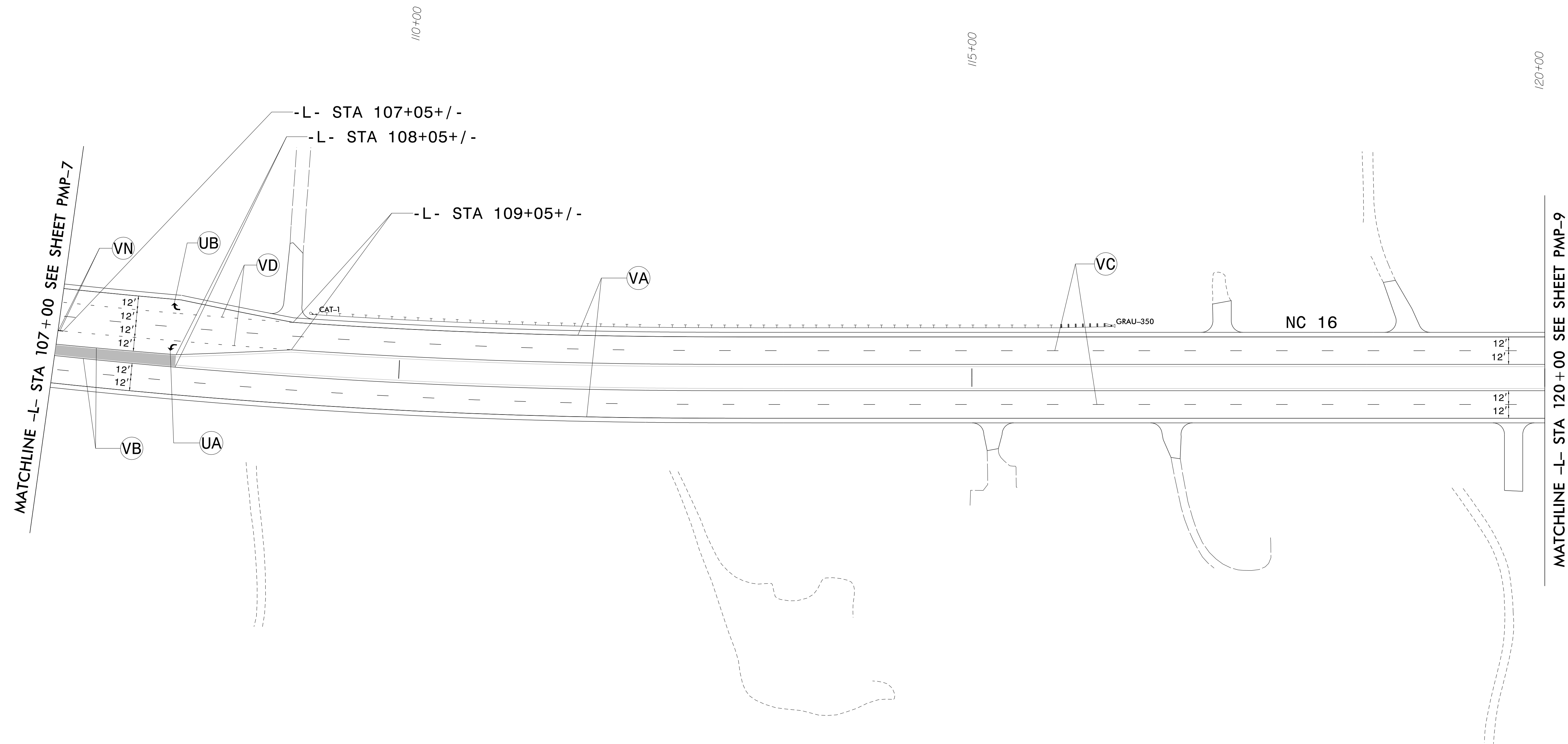
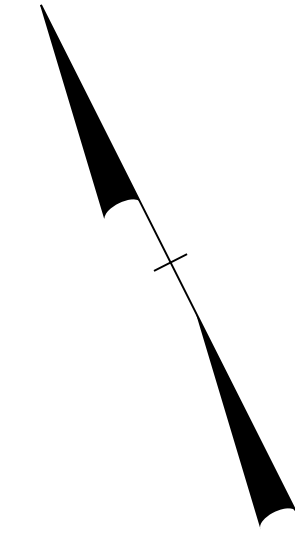

THERMOPLASTIC PAVEMENT MARKING LEGEND	
(UA)	← LEFT TURN ARROW
(UB)	→ RIGHT TURN ARROW

POLYUREA PAVEMENT MARKING LEGEND	
(VA)	WHITE EDGELINE (4")
(VB)	YELLOW EDGELINE (4")
(VC)	10 FT WHITE SKIP (4")
(VD)	3 FT - 9 FT/SP WHITE MINISKIP (4")
(VN)	WHITE GORELINE (8")

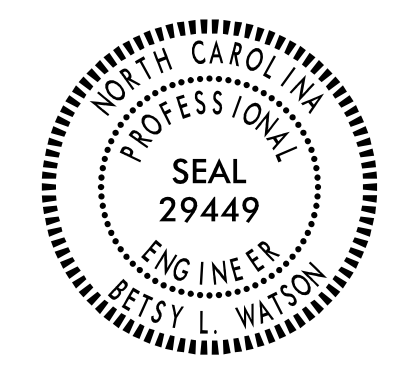

\$\$\$\$\$SYTIME\$\$\$\$\$
 \$\$\$DDGN\$\$\$\$\$
 \$\$\$USERNAM\$\$\$\$\$

PAVEMENT MARKING DETAIL

TIP NO. R-3100A	SHEET NO. PMP-9
APPROVED: <i>Betsy L. Watson</i> <small>DocuSigned by: Betsy L. Watson 35E078B34F8743F...</small>	
DATE: 9/5/2016	
SEAL	
	
DOCUMENT NOT CONSIDERED FINAL UNLESS ALL SIGNATURES COMPLETED	
	



THERMOPLASTIC PAVEMENT MARKING LEGEND	
(UT)	U-TURN ARROW
(TU)	WHITE DIAGONAL (12")

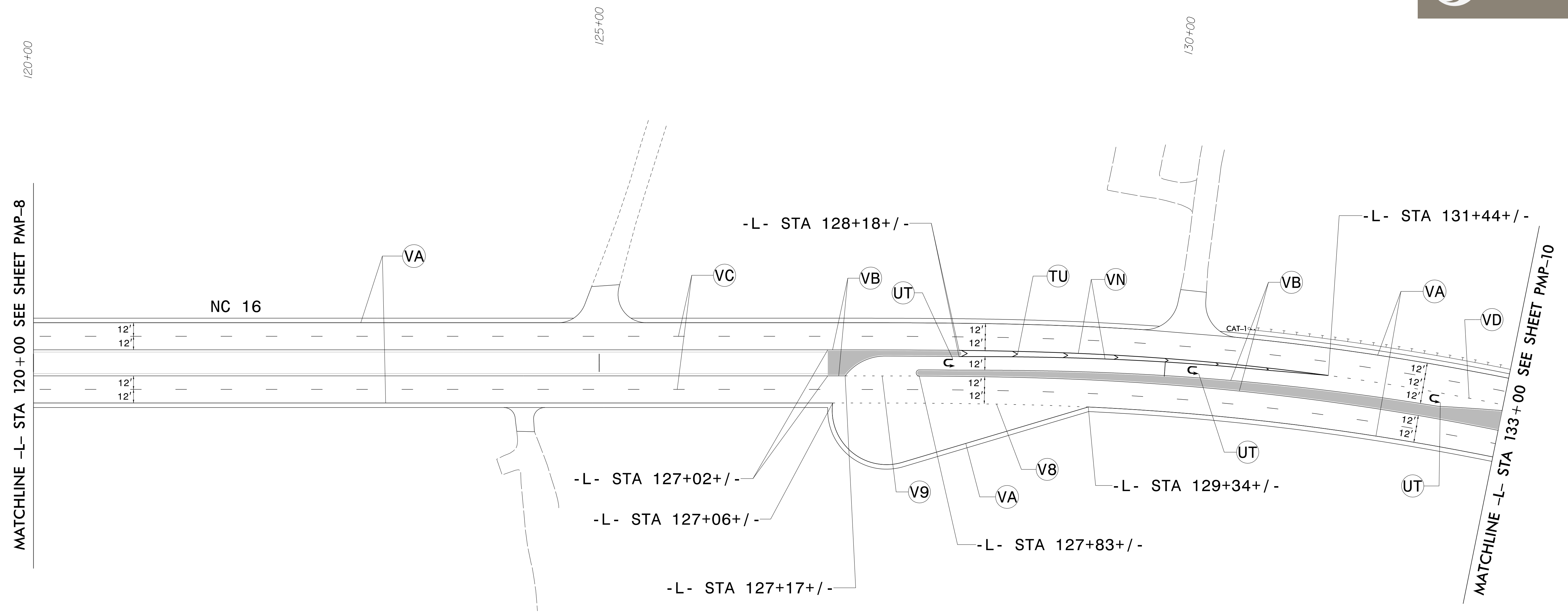
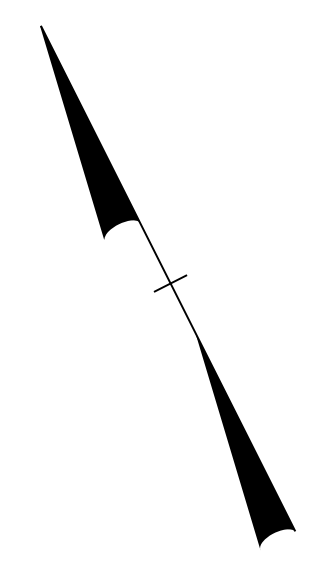

POLYUREA PAVEMENT MARKING LEGEND	
(V8)	2 FT - 6 FT/SP WHITE MINISKIP (4")
(V9)	2 FT - 6 FT/SP YELLOW MINISKIP (4")
(VA)	WHITE EDGELINE (4")
(VB)	YELLOW EDGELINE (4")
(VC)	10 FT WHITE SKIP (4")
(VD)	3 FT - 9 FT/SP WHITE MINISKIP (4")
(VN)	WHITE GORELINE (8")



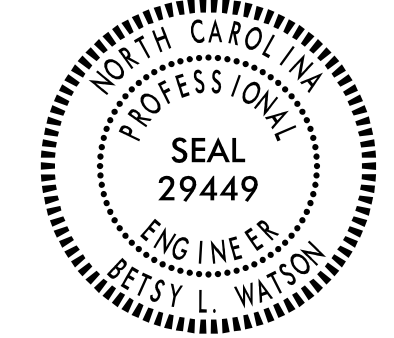

\$\$\$\$\$SYTIME\$\$\$\$\$
 \$\$\$\$\$\$DGN\$\$\$\$\$
 \$\$\$\$\$\$USERNAME\$\$\$\$\$

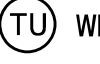
PAVEMENT MARKING DETAIL

TIP NO. R-3100A	SHEET NO. PMP-10
APPROVED: <i>Betsy L. Watson</i> <small>DocuSigned by: Betsy L. Watson 35E978B34F8743F</small>	
DATE: 9/5/2016	
SEAL 	
DOCUMENT NOT CONSIDERED FINAL UNLESS ALL SIGNATURES COMPLETED	
	

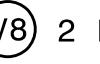
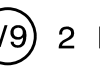
THERMOPLASTIC PAVEMENT MARKING LEGEND			
	LEFT TURN ARROW		WHITE DIAGONAL (12")
	RIGHT TURN ARROW		YELLOW DIAGONAL (12")

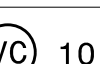
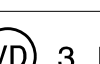
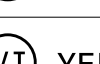
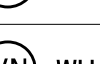
POLYUREA PAVEMENT MARKING LEGEND	
	2 FT - 6 FT/SP WHITE MINISKIP (4")
	2 FT - 6 FT/SP YELLOW MINISKIP (4")
	WHITE EDGELINE (4")
	YELLOW EDGELINE (4")
	10 FT WHITE SKIP (4")
	3 FT - 9 FT/SP WHITE MINISKIP (4")
	YELLOW DOUBLE CENTER (4")
	WHITE GORELINE (8")

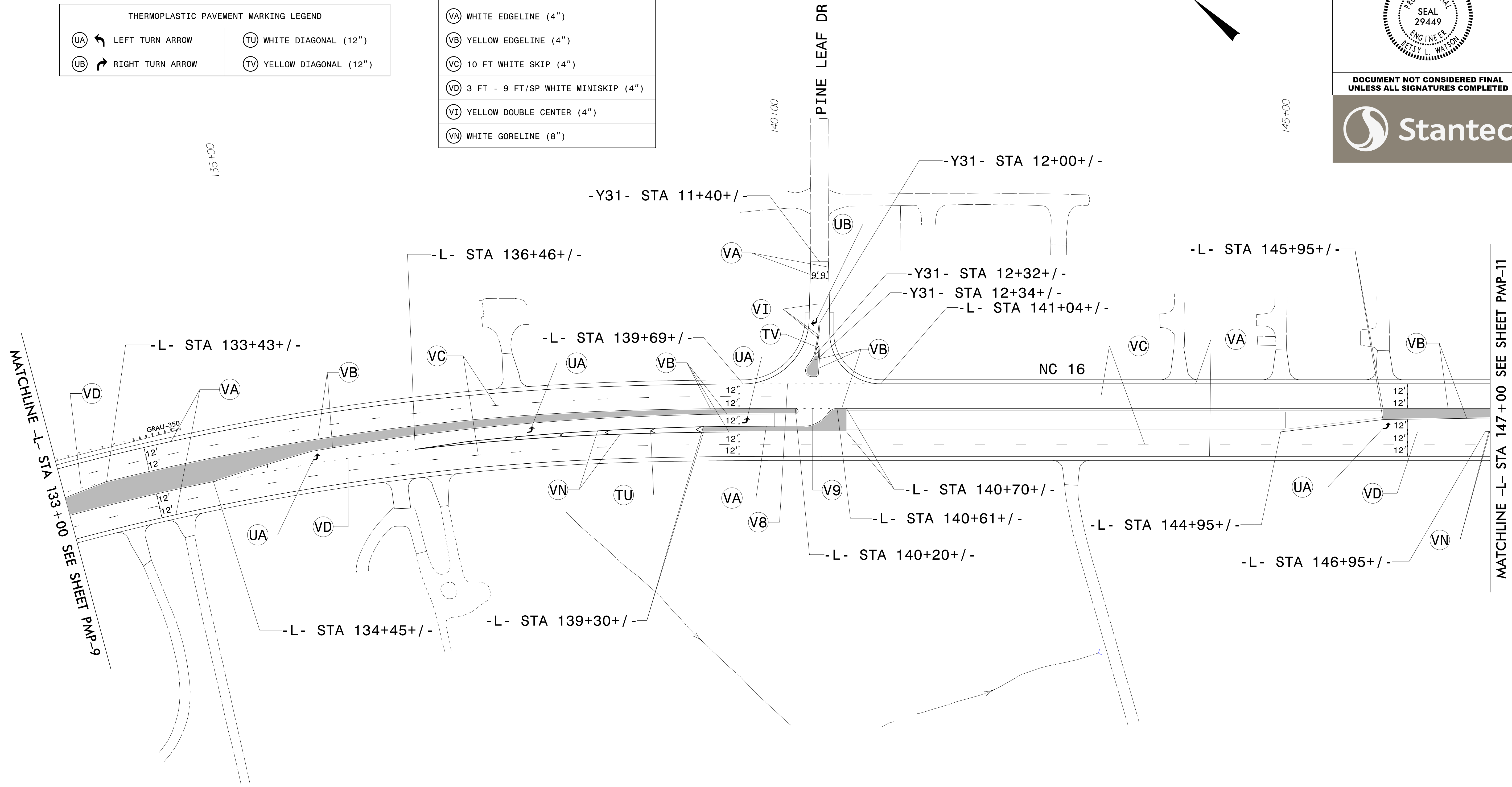

\$\$\$\$\$SYTIME\$\$\$\$\$
 \$\$\$\$DDGN\$\$\$\$\$
 \$\$\$\$USERNAME\$\$\$\$\$

PAVEMENT MARKING DETAIL

TIP NO. R-3100A	SHEET NO. PMP-11
APPROVED: <i>Betsy L. Watson</i> 35E678934F9743F	
DATE: 9/5/2016	
SEAL	
DOCUMENT NOT CONSIDERED FINAL UNLESS ALL SIGNATURES COMPLETED	

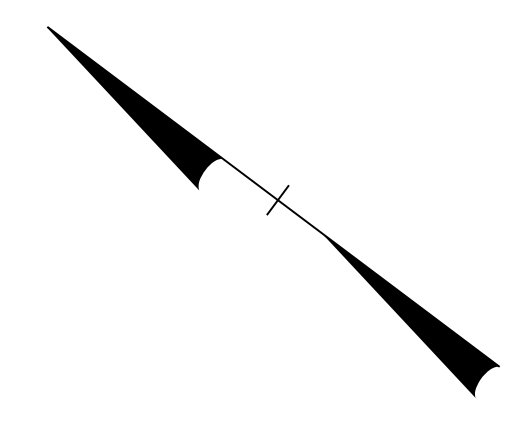

* TIE TO EXISTING

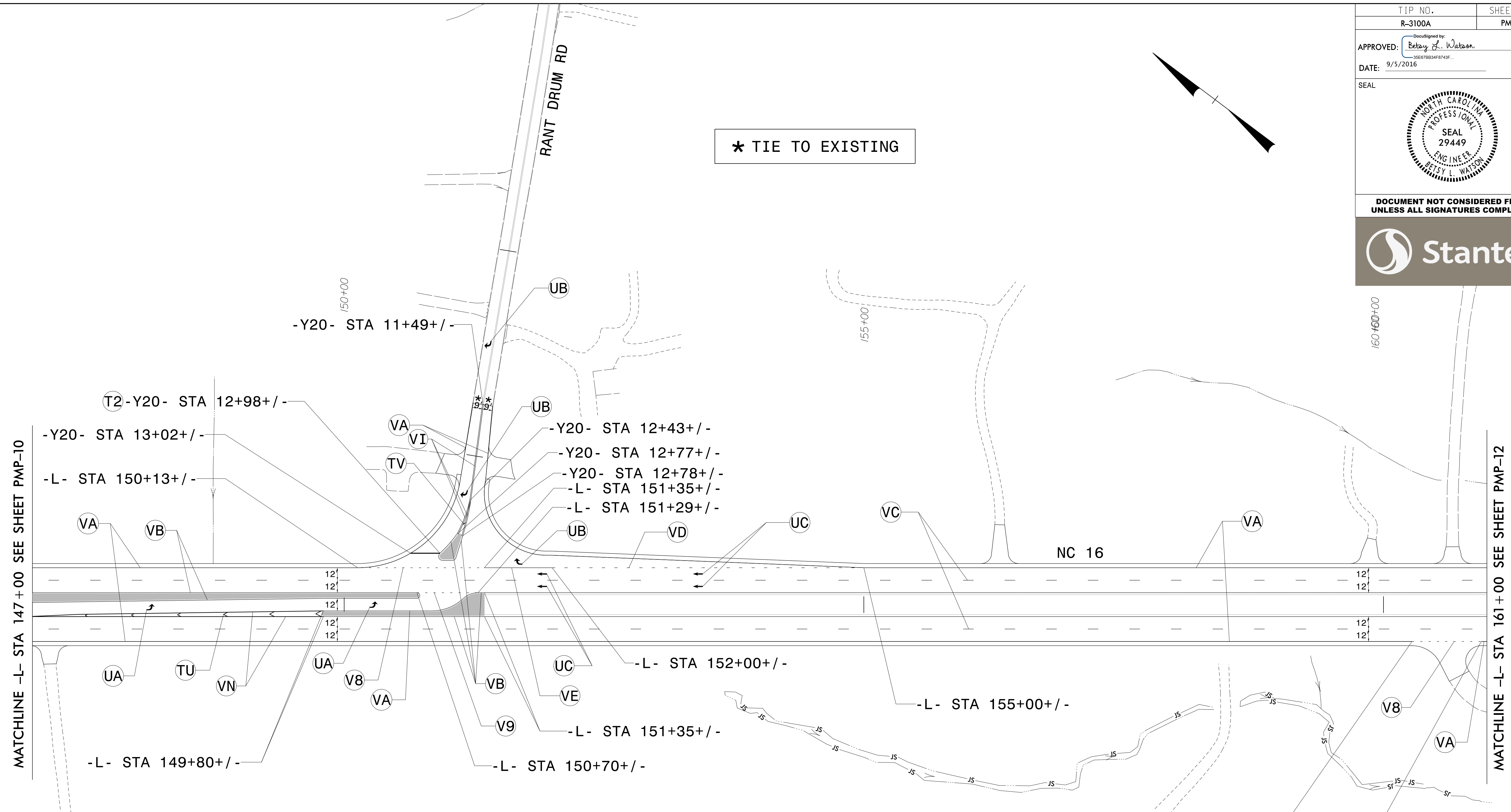

THERMOPLASTIC PAVEMENT MARKING LEGEND	
(UA) ↶	LEFT TURN ARROW
(UB) ↷	RIGHT TURN ARROW
(UC) ↑	STRAIGHT ARROW
(T2)	WHITE STOPBAR (24")
(TU)	WHITE DIAGONAL (12")
(TV)	YELLOW DIAGONAL (12")

POLYUREA PAVEMENT MARKING LEGEND	
(V8)	2 FT - 6 FT/SP WHITE MINISKIP (4")
(V9)	2 FT - 6 FT/SP YELLOW MINISKIP (4")
(VA)	WHITE EDGELINE (4")
(VB)	YELLOW EDGELINE (4")
(VC)	10 FT WHITE SKIP (4")
(VD)	3 FT - 9 FT/SP WHITE MINISKIP (4")
(VE)	WHITE SOLID LANE LINE (4")
(VI)	YELLOW DOUBLE CENTER (4")
(VN)	WHITE GORELINE (8")

\$\$\$SYTIME\$\$\$\$\$
 \$\$\$DGN\$\$\$\$\$
 \$\$\$USERNAME\$\$\$\$\$

PAVEMENT MARKING DETAIL

TIP NO. R-3100A	SHEET NO. PMP-12
APPROVED: <i>Betsy L. Watson</i> 35E078B34F8743F	
DATE: 9/5/2016	
SEAL	
DOCUMENT NOT CONSIDERED FINAL UNLESS ALL SIGNATURES COMPLETED	

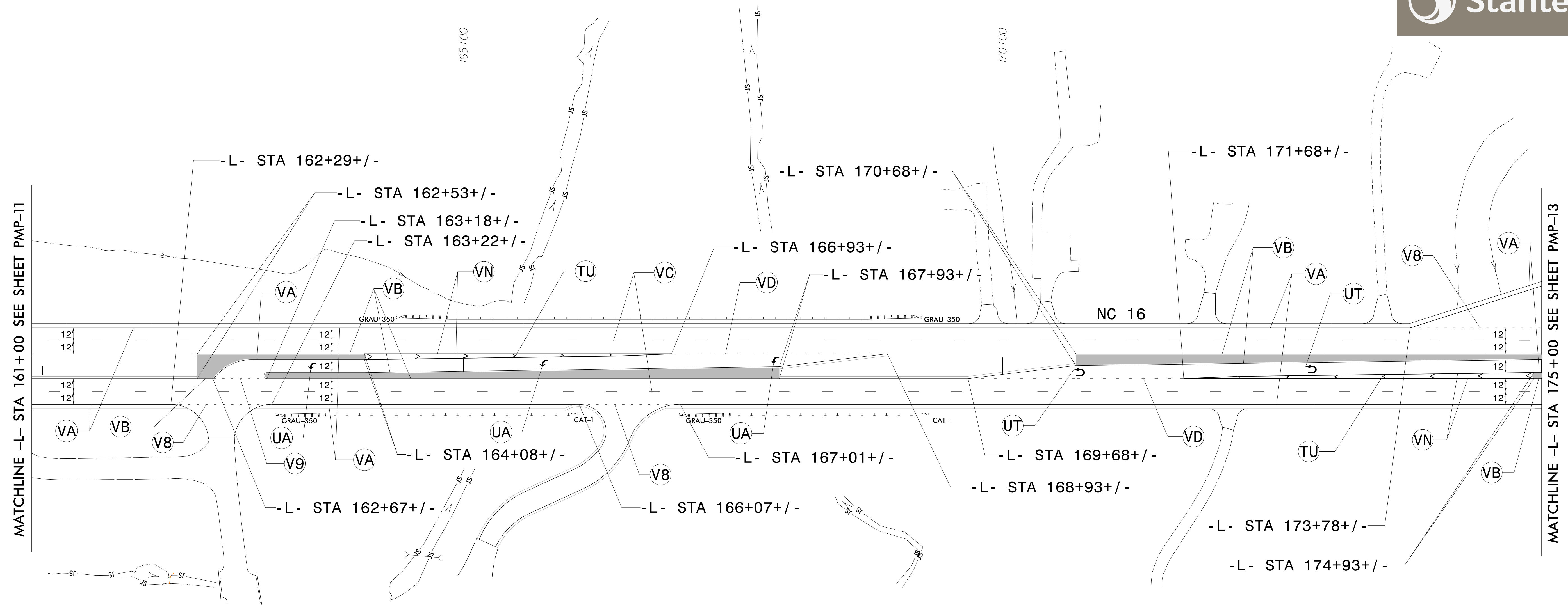
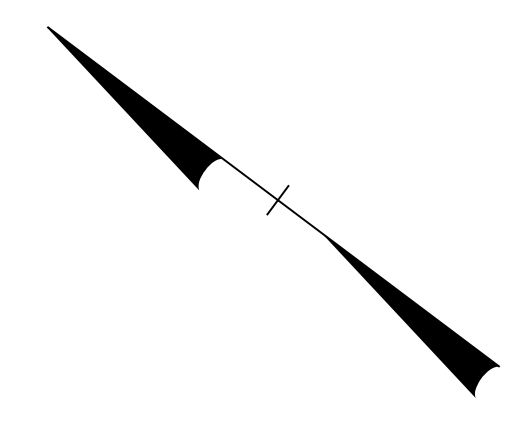

MATCHLINE -L- STA 161+00 SEE SHEET PMP-11



MATCHLINE -L- STA 175+00 SEE SHEET PMP-13

THERMOPLASTIC PAVEMENT MARKING LEGEND	
LEFT TURN ARROW	WHITE DIAGONAL (12")
U-TURN ARROW	



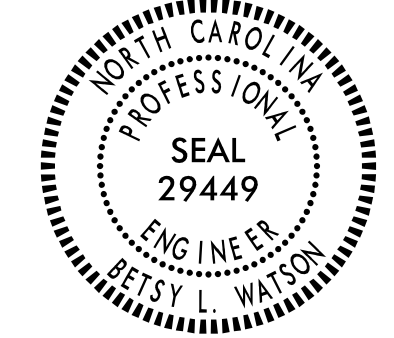

POLYUREA PAVEMENT MARKING LEGEND	
2 FT - 6 FT/SP WHITE MINISKIP (4")	
2 FT - 6 FT/SP YELLOW MINISKIP (4")	
WHITE EDGELINE (4")	
YELLOW EDGELINE (4")	
10 FT WHITE SKIP (4")	
3 FT - 9 FT/SP WHITE MINISKIP (4")	
WHITE GORELINE (8")	



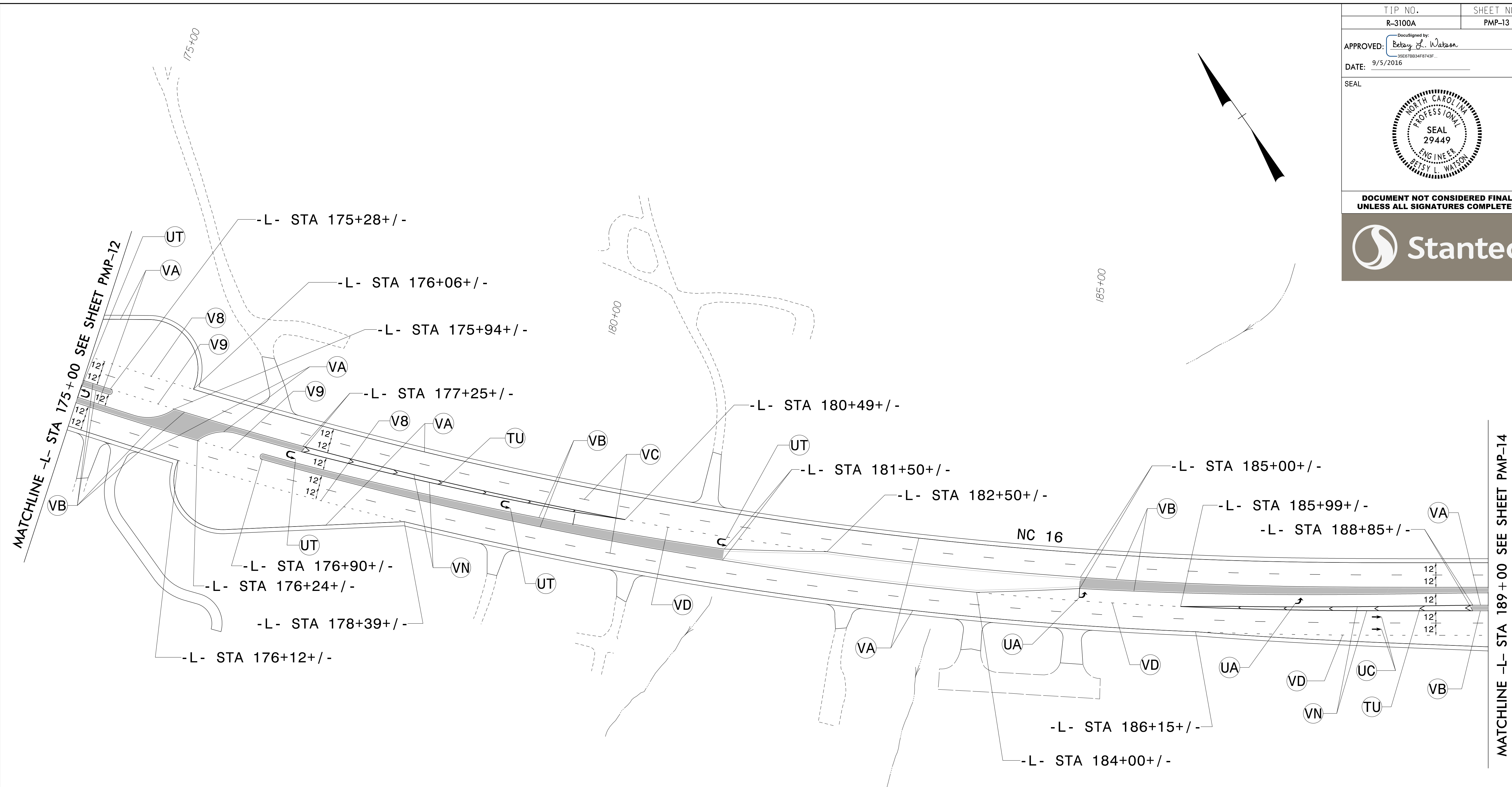



PAVEMENT MARKING DETAIL

\$\$\$\$\$SYTIME\$\$\$\$\$
\$\$\$\$\$DGN\$\$\$\$\$
\$\$\$\$\$USERNAME\$\$\$\$\$

TIP NO. R-3100A	SHEET NO. PMP-13
APPROVED: <i>Betsy L. Watson</i> DocuSigned by: Betsy L. Watson 35E78B34F743F	
DATE: 9/5/2016	
SEAL	
	
DOCUMENT NOT CONSIDERED FINAL UNLESS ALL SIGNATURES COMPLETED	
	





THERMOPLASTIC PAVEMENT MARKING LEGEND	
 LEFT TURN ARROW	 WHITE DIAGONAL (12")
 STRAIGHT ARROW	
 U-TURN ARROW	

POLYUREA PAVEMENT MARKING LEGEND	
 2 FT - 6 FT/SP WHITE MINISKIP (4")	
 2 FT - 6 FT/SP YELLOW MINISKIP (4")	
 WHITE EDGELINE (4")	
 YELLOW EDGELINE (4")	
 10 FT WHITE SKIP (4")	
 3 FT - 9 FT/SP WHITE MINISKIP (4")	
 WHITE GORELINE (8")	

PAVEMENT MARKING DETAIL

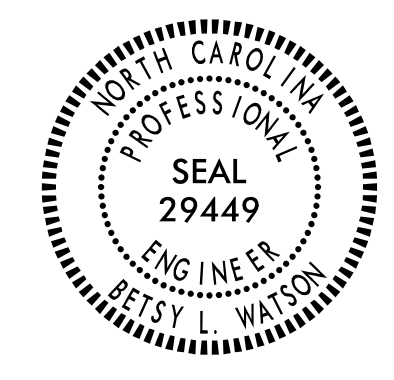
\$\$\$\$\$SYTIME\$\$\$\$\$
 \$\$\$DDGN\$\$\$\$\$
 \$\$\$USERNAME\$\$\$\$\$

TIP NO. R-3100A	SHEET NO. PMP-14
APPROVED: <i>Estey L. Watson</i> <small>DocuSigned by: Estey L. Watson 356878834F8743F...</small>	
DATE: 9/22/2016	
SEAL	
	
<p>DOCUMENT NOT CONSIDERED FINAL UNLESS ALL SIGNATURES COMPLETED</p>	
	

ⓐ LEFT TURN ARROW	Ⓣ₂ WHITE STOPBAR (24")
ⓑ RIGHT TURN ARROW	Ⓣₐ WHITE EDGELINE (4")
ⓒ STRAIGHT ARROW	Ⓣₙ WHITE GORELINE (8")
Ⓨ UN ▼▼▼ 24" YIELD LINE TRIANGLE	Ⓣᵤ WHITE DIAGONAL (12")
	Ⓣᵥ YELLOW DIAGONAL (12")

Ⓥ₈ 2 FT - 6 FT/SP WHITE MINISKIP (4")
Ⓥ₉ 2 FT - 6 FT/SP YELLOW MINISKIP (4")
Ⓥₐ WHITE EDGELINE (4")
Ⓥᵇ YELLOW EDGELINE (4")
Ⓥᶜ 10 FT WHITE SKIP (4")
Ⓥᵀ 3 FT - 9 FT/SP WHITE MINISKIP (4")
Ⓥᵀᵀ YELLOW DOUBLE CENTER (4")
Ⓥₙ WHITE GORELINE (8")

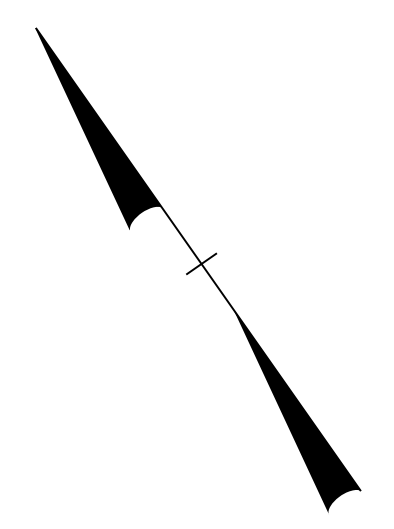

200+00

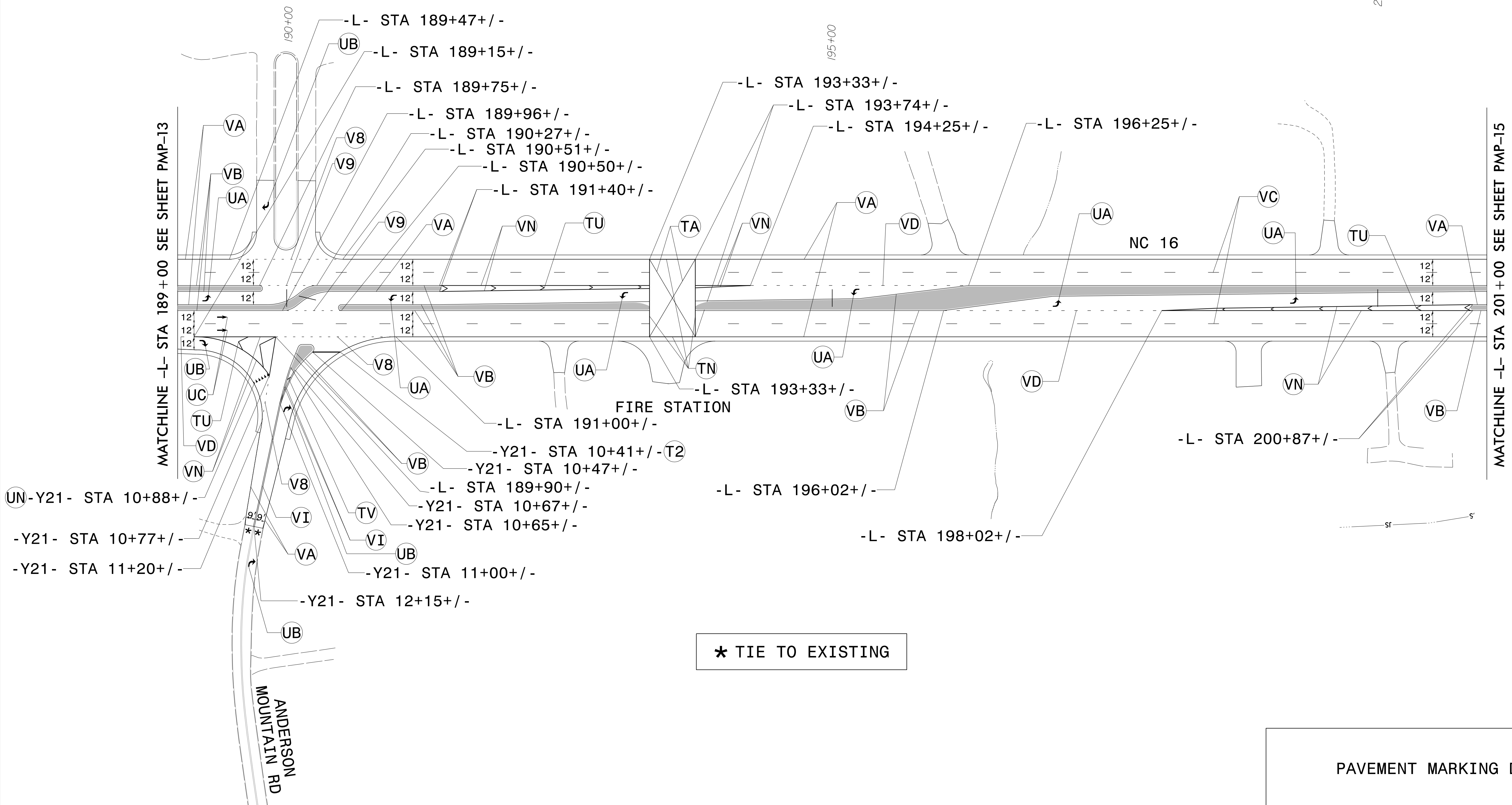

* TIE TO EXISTING

PAVEMENT MARKING DETAIL

\$\$\$\$\$SYTIME\$\$\$\$\$
\$\$\$\$\$DGN\$\$\$\$\$
\$\$\$\$\$USERNAME\$\$\$\$\$

APPROVED: *Betsy L. Watson*
DATE: 9/5/2016

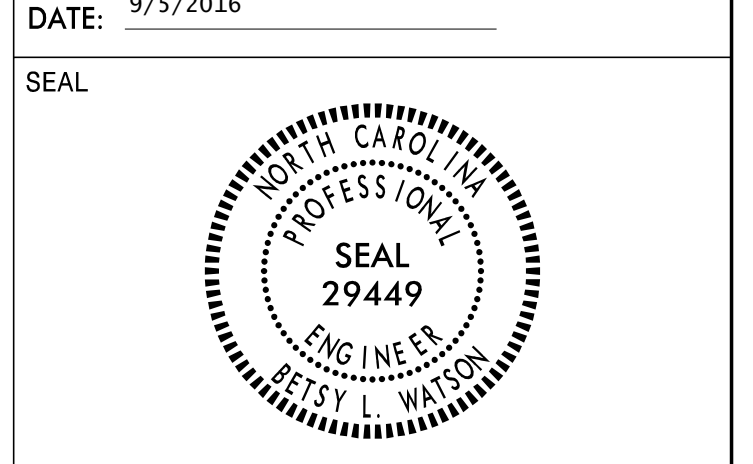

DOCUMENT NOT CONSIDERED FINAL
UNLESS ALL SIGNATURES COMPLETED



THERMOPLASTIC PAVEMENT MARKING LEGEND	
(UA) LEFT TURN ARROW	(T2) WHITE STOPBAR (24")
(UB) RIGHT TURN ARROW	(TU) WHITE DIAGONAL (12")
(UC) STRAIGHT ARROW	(TV) YELLOW DIAGONAL (12")

POLYUREA PAVEMENT MARKING LEGEND	
(V8) 2 FT - 6 FT/SP WHITE MINISKIP (4")	(VA) WHITE EDGELINE (4")
(V9) 2 FT - 6 FT/SP YELLOW MINISKIP (4")	(VB) YELLOW EDGELINE (4")
(VC) 10 FT WHITE SKIP (4")	(VD) 3 FT - 9 FT/SP WHITE MINISKIP (4")
(VE) WHITE SOLID LANE LINE (4")	(VI) YELLOW DOUBLE CENTER (4")
(VN) WHITE GORELINE (8")	

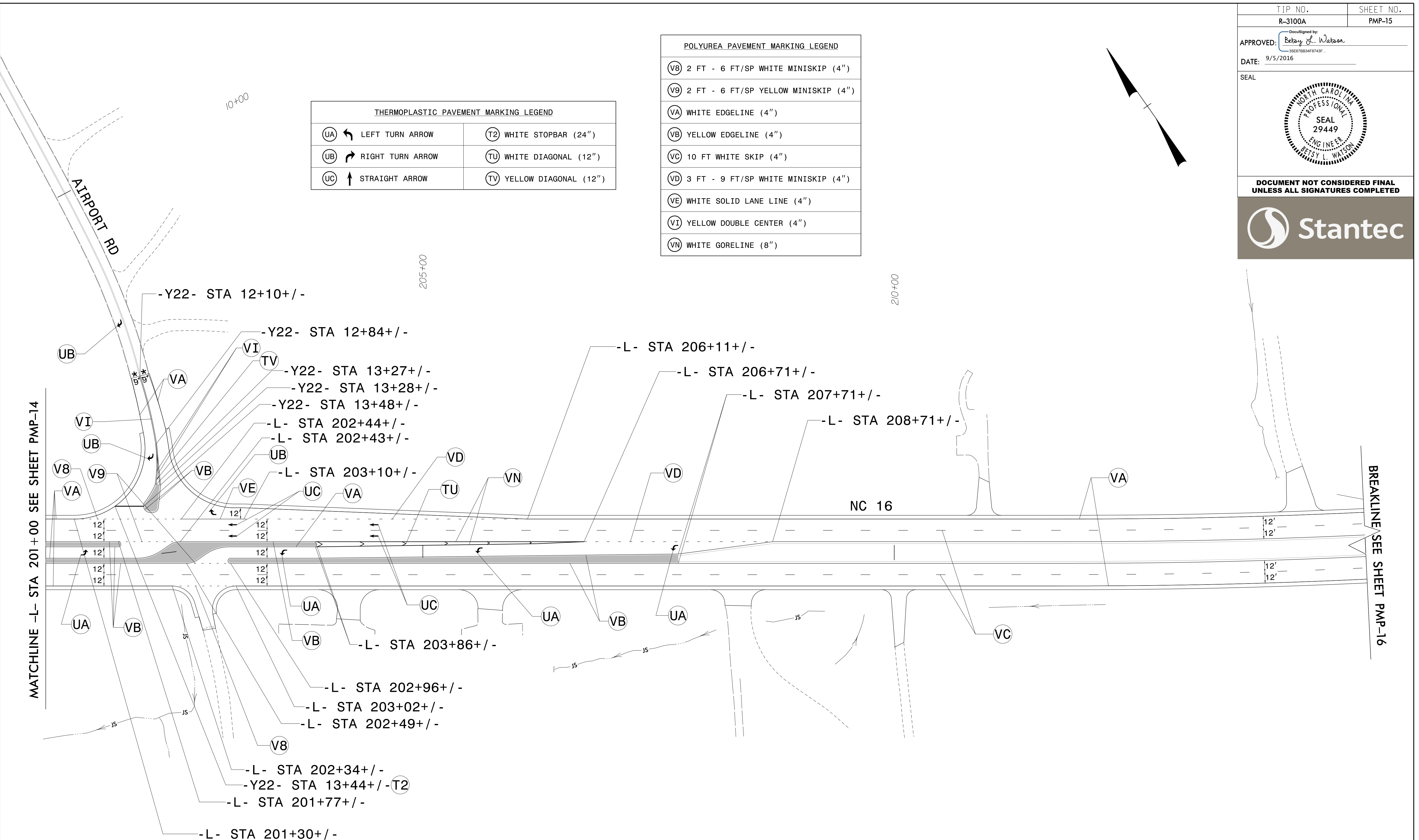
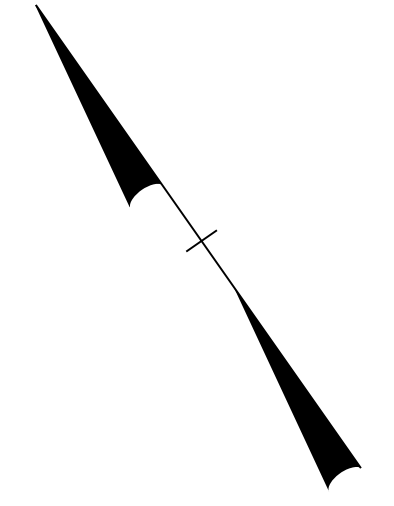



MATCHLINE -L- STA 201+00 SEE SHEET PMP-14

BREAKLINE SEE SHEET PMP-16

* TIE TO EXISTING

\$\$\$\$\$SYTIME\$\$\$\$\$
\$\$\$\$\$DDGN\$\$\$\$\$
\$\$\$\$\$USERNAME\$\$\$\$\$

PAVEMENT MARKING DETAIL

TIP NO. R-3100A	SHEET NO. PMP-16
APPROVED: <i>Betsy L. Watson</i> <small>DocuSigned by: Betsy L. Watson 35E978B34F8743F</small>	
DATE: 9/5/2016	
SEAL	
	
DOCUMENT NOT CONSIDERED FINAL UNLESS ALL SIGNATURES COMPLETED	
	

THERMOPLASTIC PAVEMENT MARKING LEGEND	
(UT)	U-TURN ARROW
(TU)	WHITE DIAGONAL (12")

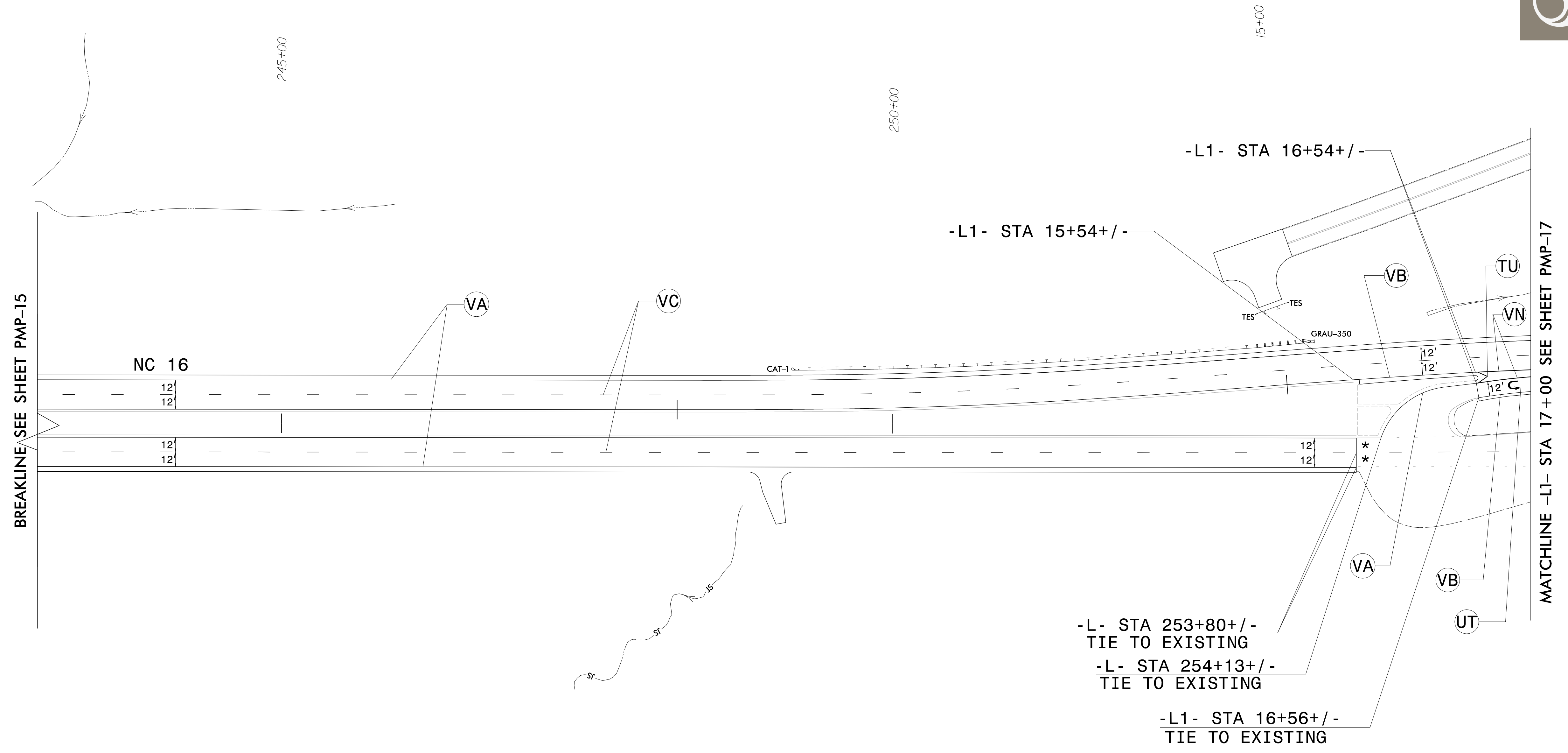
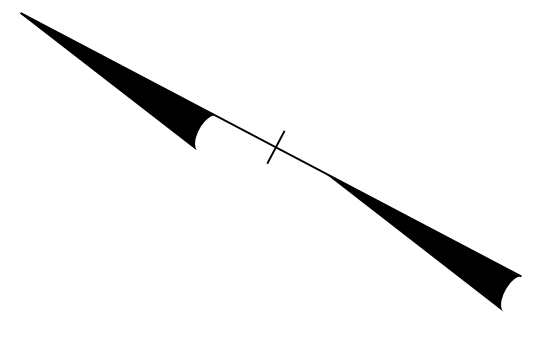

POLYUREA PAVEMENT MARKING LEGEND	
(VA)	WHITE EDGELINE (4")
(VB)	YELLOW EDGELINE (4")
(VC)	10 FT WHITE SKIP (4")
(VN)	WHITE GORELINE (8")



*** TIE TO EXISTING**

PAVEMENT MARKING DETAIL

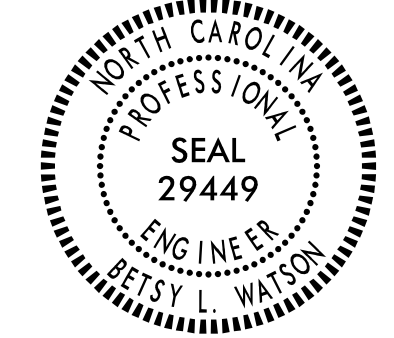
\$\$\$\$\$SYTIME\$\$\$\$\$
 \$\$\$\$\$\$DGN\$\$\$\$\$
 \$\$\$\$\$\$USERNAME\$\$\$\$\$

TIP NO. R-3100A	SHEET NO. PMP-17
APPROVED: <i>Betsy L. Watson</i> DocuSigned by: Betsy L. Watson 35E678B34F8743F...	
DATE: 9/21/2016	
SEAL	
	
DOCUMENT NOT CONSIDERED FINAL UNLESS ALL SIGNATURES COMPLETED	
	

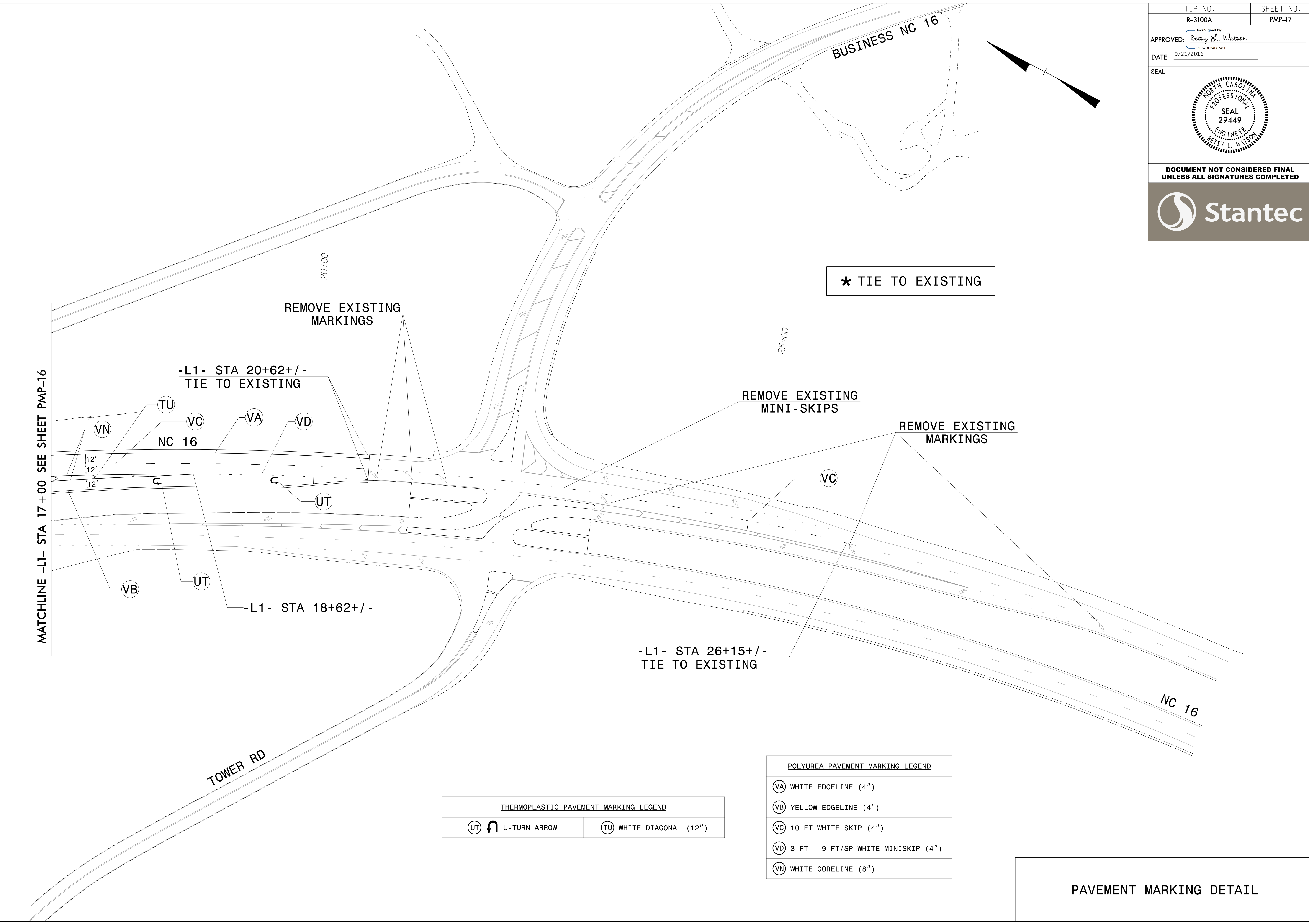

MATCHLINE -L1- STA 17+00 SEE SHEET PMP-16

REMOVE EXISTING MARKINGS

-L1- STA 20+62+/-
TIE TO EXISTING

* TIE TO EXISTING

REMOVE EXISTING MINI-SKIPS



REMOVE EXISTING MARKINGS





-L1- STA 26+15+/-
TIE TO EXISTING

-L1- STA 18+62+/-

NC 16

TOWER RD

THERMOPLASTIC PAVEMENT MARKING LEGEND	
 U-TURN ARROW	 WHITE DIAGONAL (12")

POLYUREA PAVEMENT MARKING LEGEND	
 WHITE EDGELINE (4")	
 YELLOW EDGELINE (4")	
 10 FT WHITE SKIP (4")	
 3 FT - 9 FT/SP WHITE MINISKIP (4")	
 WHITE GORELINE (8")	

PAVEMENT MARKING DETAIL

\$\$\$\$\$SYTIME\$\$\$\$\$
\$\$\$\$\$DGN\$\$\$\$\$
\$\$\$\$\$USERNAME\$\$\$\$\$