

8/17/99

Prepared by
URS
URS Corporation - North Carolina
1600 Perimeter Park Drive
Morrisville, North Carolina 27560
TELEPHONE: (919) 461-1100 FAX: (919) 461-1415
NC LICENSE # C-22843

PROJECT REFERENCE NO. R-3100B	SHEET NO. 5
R/W SHEET NO.	HYDRAULICS ENGINEER
ROADWAY DESIGN ENGINEER	SEAL 18470 EDWARD GLENN EDWARDS JR. ENGINEER 3/16/2017
	SEAL 037863 MEME D. BUSCENI ENGINEER 3/20/2017
DOCUMENT NOT CONSIDERED FINAL UNLESS ALL SIGNATURES COMPLETED	

-L-
 PI Sta 22+04.68
 $\Delta = 32' 22" 12.2" (LT)$
 $D = 2' 4" 0.11"$
 $L = 1,206.20'$
 $T = 619.67'$
 $R = 2,135.00'$
 $e = 3\%$
 Runoff = 108'

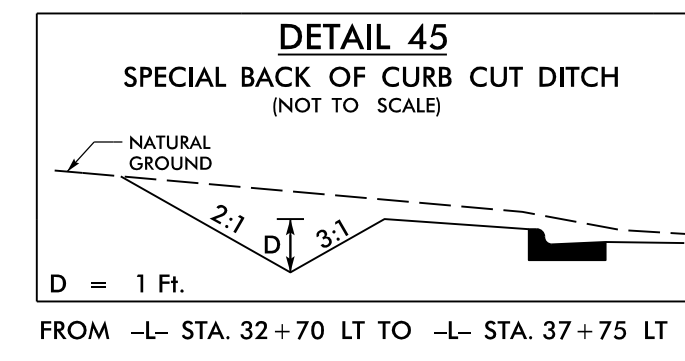
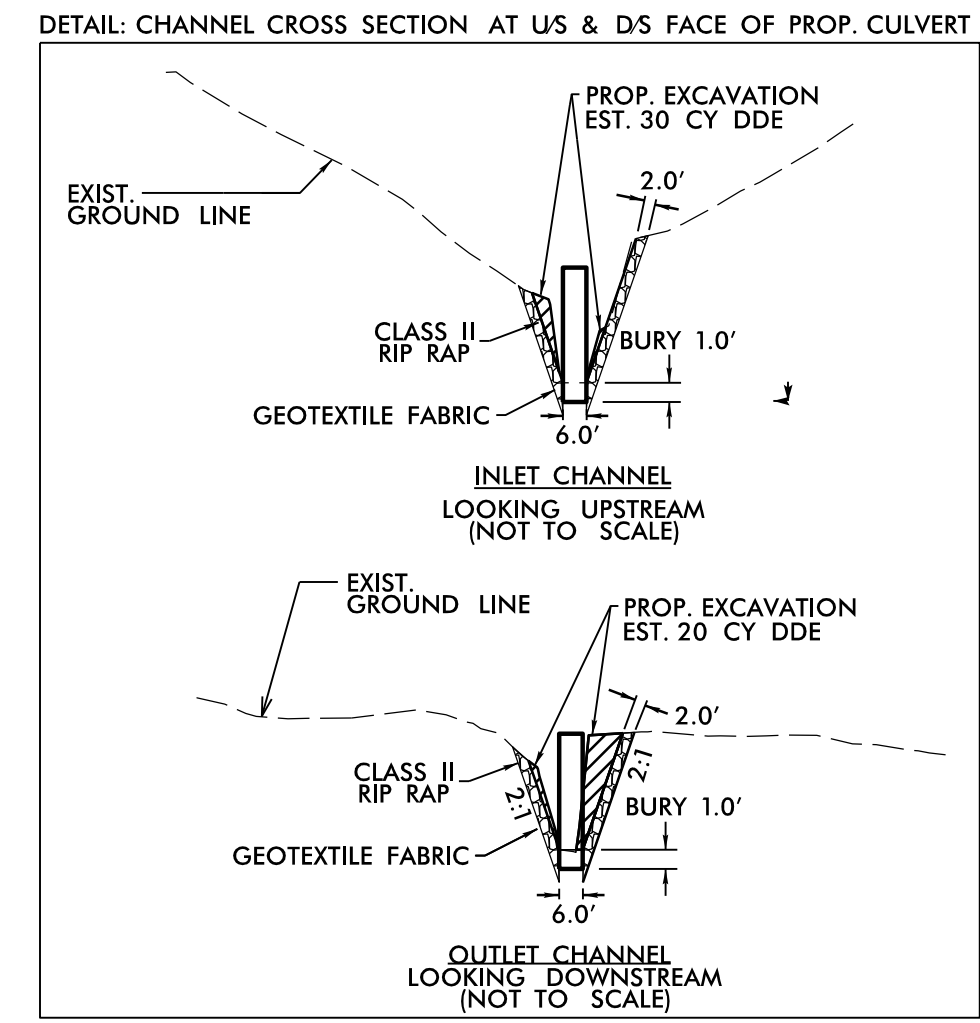

NAD 83
NSRS 2007

REVISIONS

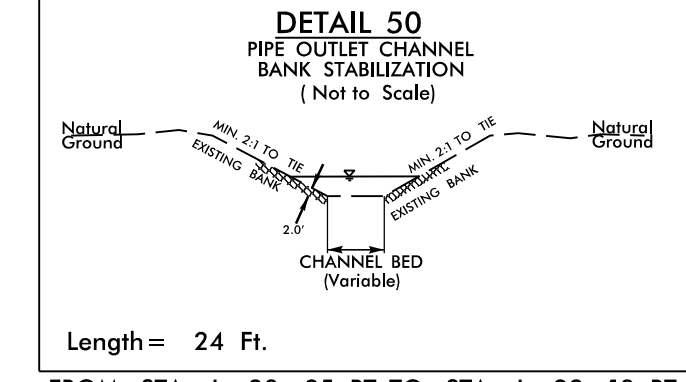
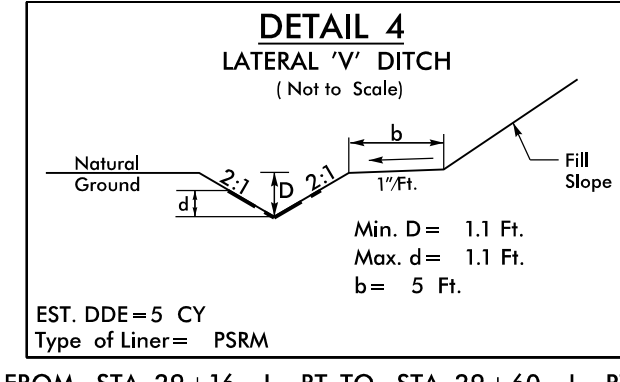
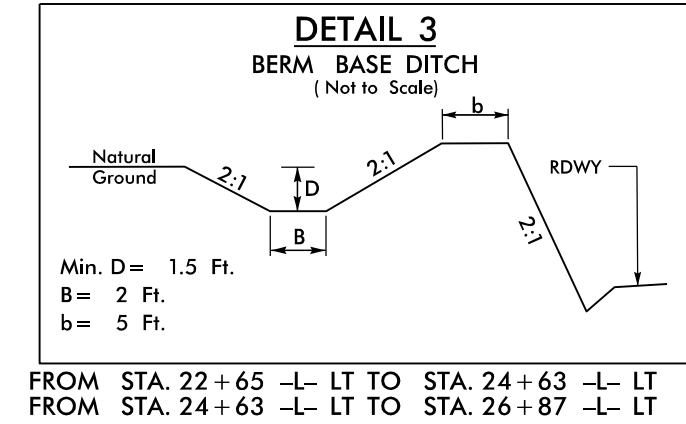
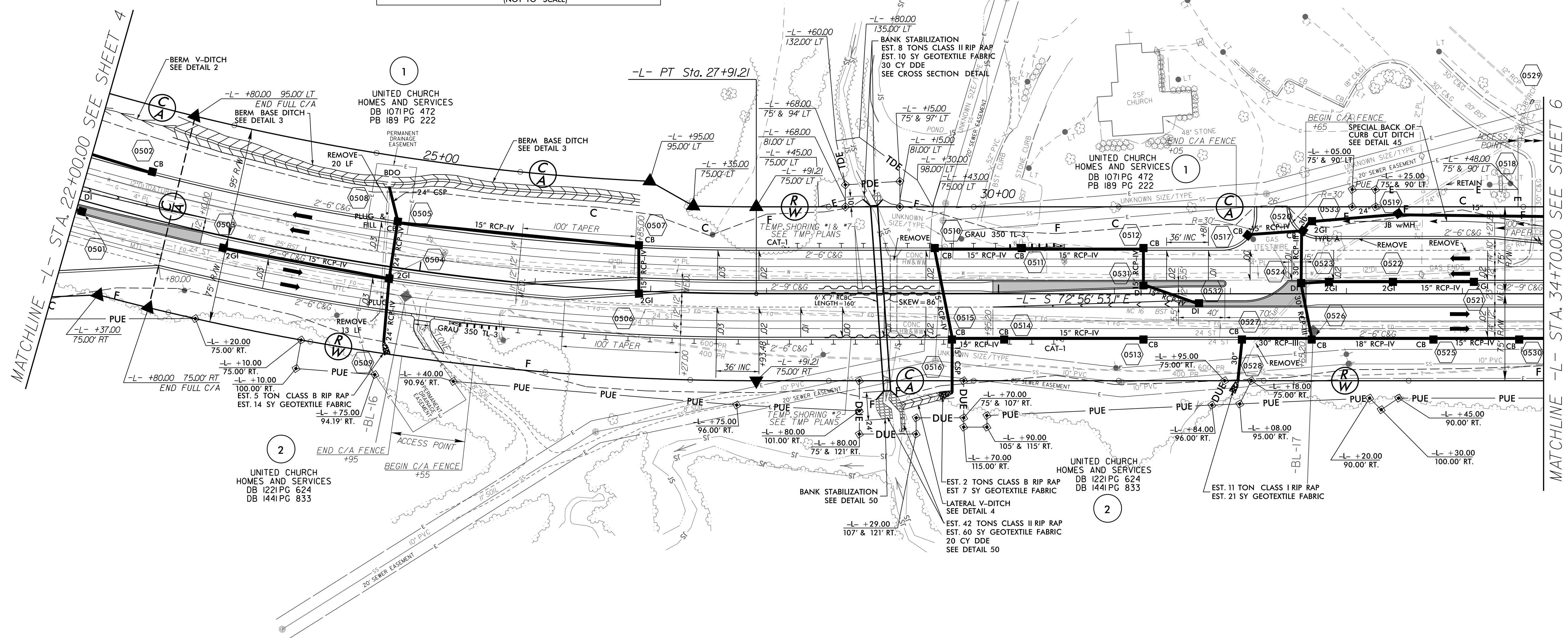

FOR -L- PROFILE SEE SHEET 18
FOR CONC. MONO. ISLAND DETAIL SEE SHEET 2B-1

3/16/2017
R:\Roadway\Proj\17-3100b_rdy_PSH05.dgn
schield