

5/28/99

Prepared by
URS
 1600 Perimeter Park Drive, Suite 400
 Morrisville, North Carolina 27560
 Phone (919)461-1100 Fax (919)461-1415
 NC Lic.# C-2243

PROJECT REFERENCE NO. R-3100B	SHEET NO. 21
ROADWAY DESIGN ENGINEER 	HYDRAULICS ENGINEER 

DOCUMENT NOT CONSIDERED FINAL UNLESS ALL SIGNATURES COMPLETED

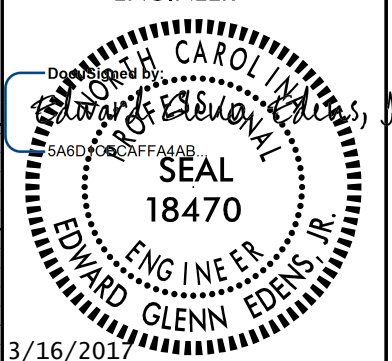
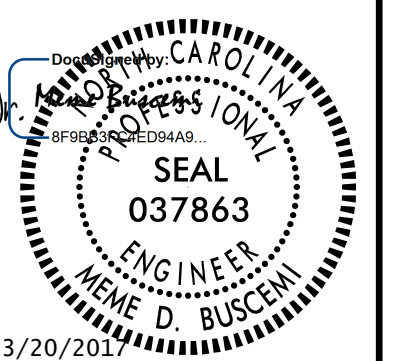
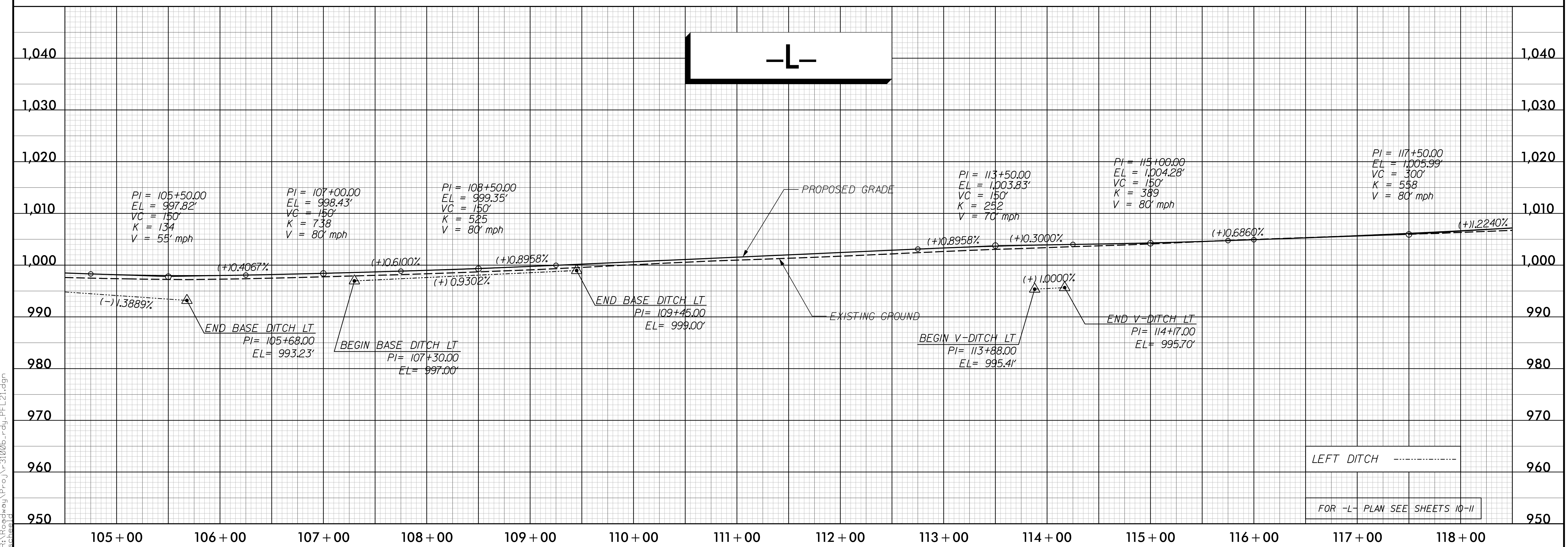
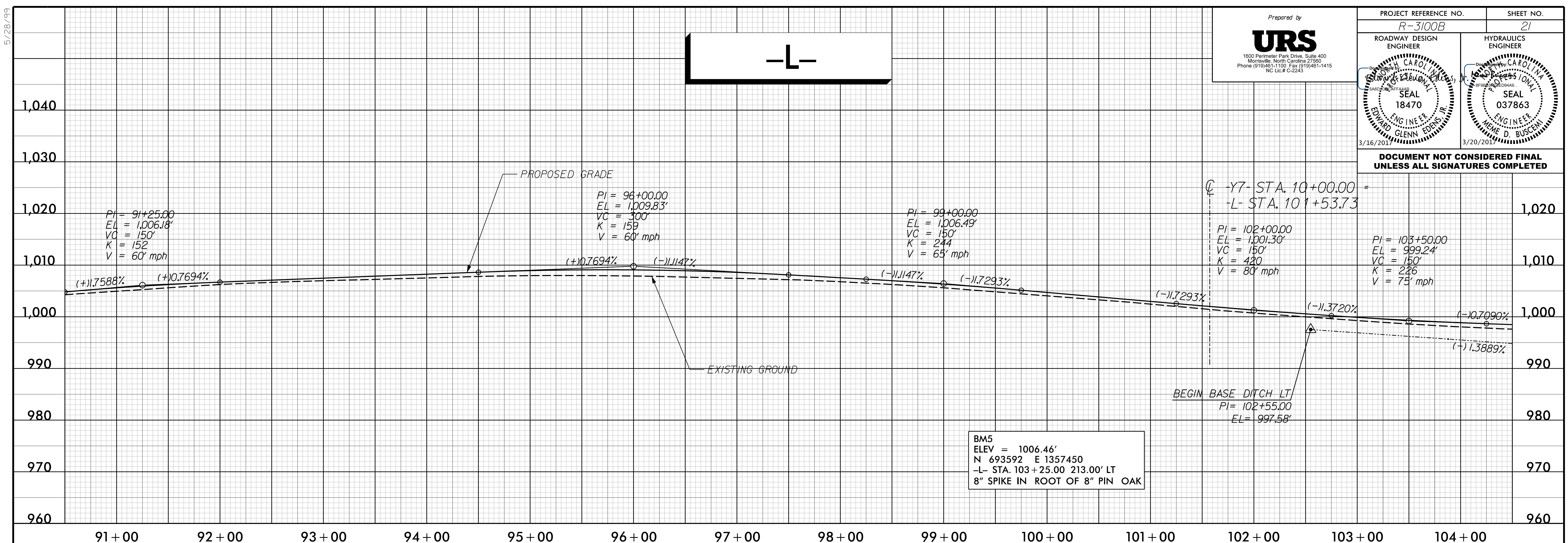

3/16/2017 R:\Roadway\ProJ\3100b_rdu_PFL21.dgn