

8/17/99

Prepared by  
**URS**  
 URS Corporation - North Carolina  
 1600 Perimeter Park Drive  
 Morrisville, North Carolina 27560  
 TELEPHONE (919) 461-1100 FAX (919) 461-1415  
 NC LIC# 000666 - C-2294

PROJECT REFERENCE NO. <b>R-3100B</b>	SHEET NO. <b>8</b>
R/W SHEET NO. ROADWAY DESIGN ENGINEER	HYDRAULICS ENGINEER
DOCUMENT NOT CONSIDERED FINAL UNLESS ALL SIGNATURES COMPLETED	

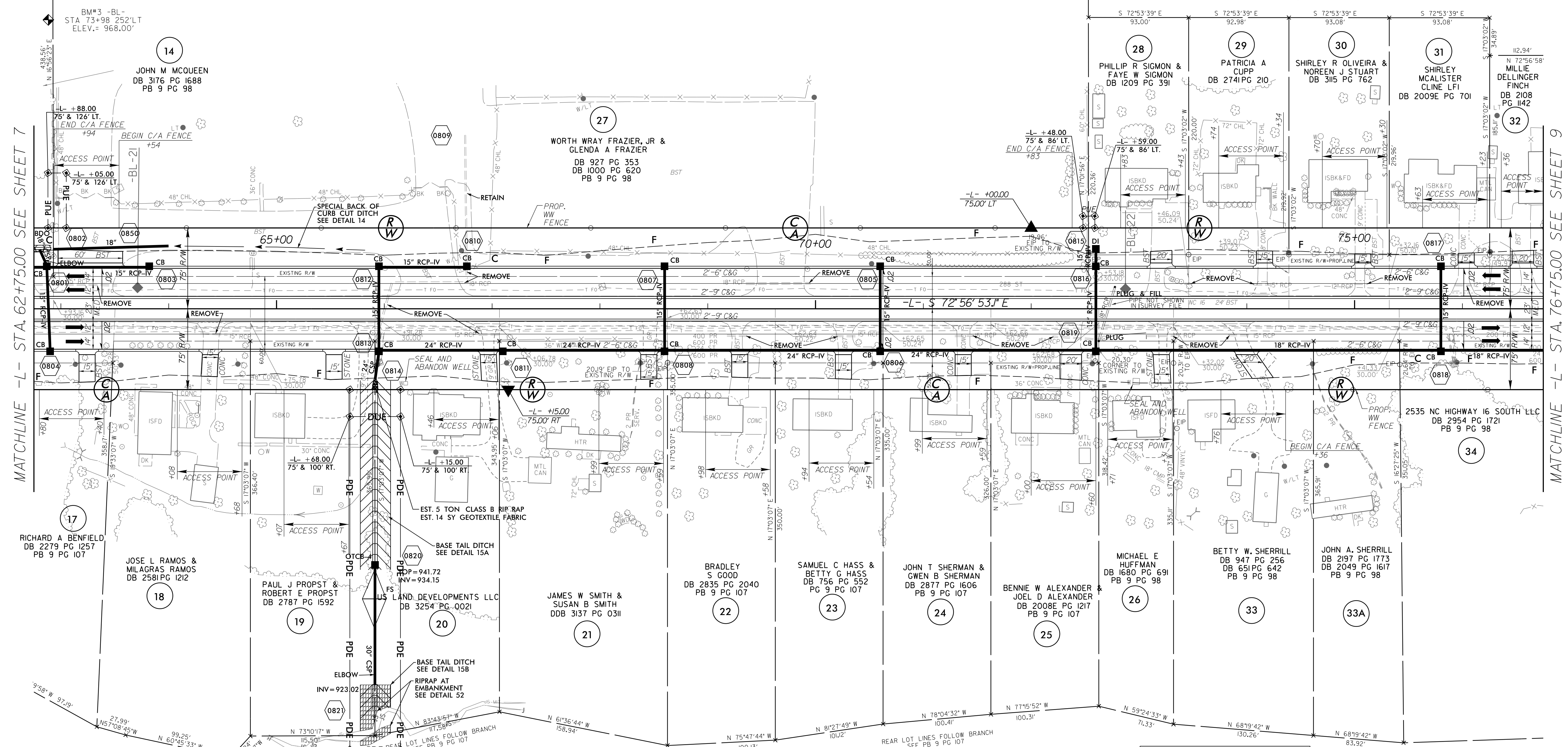
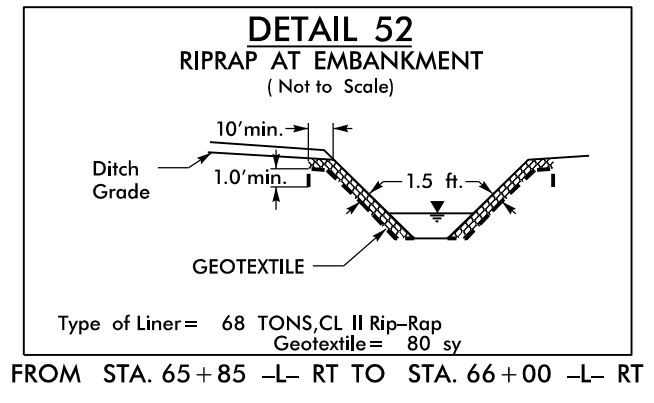

MATCHLINE -L- STA. 62+75.00 SEE SHEET 7

MATCHLINE -L- STA. 76+75.00 SEE SHEET 9

REVISIONS

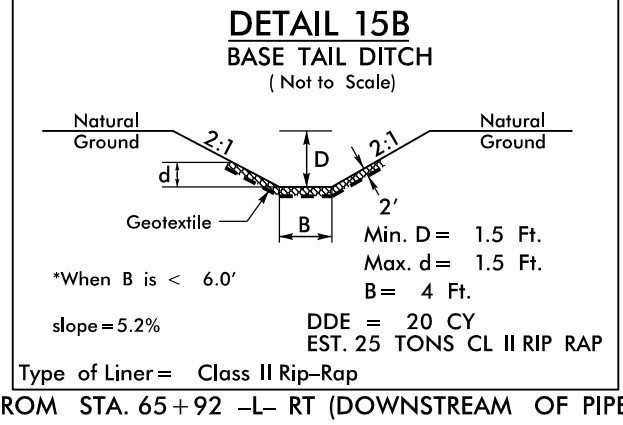
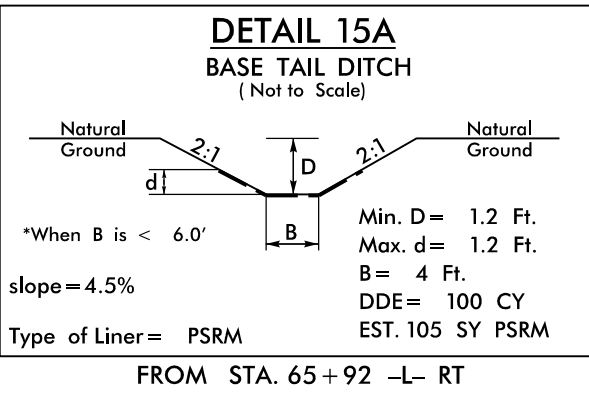
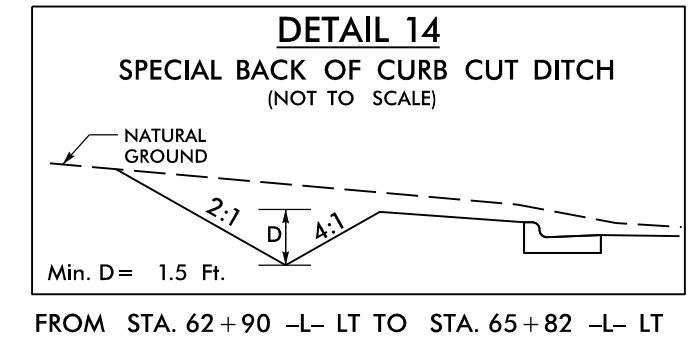
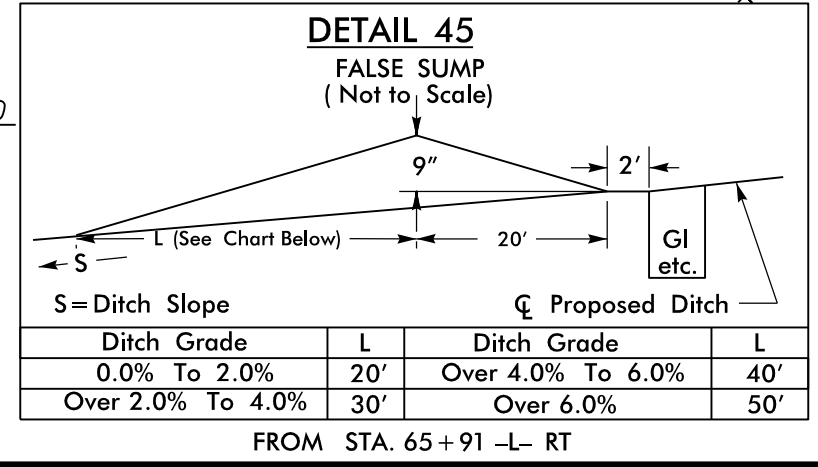

FOR -L- PROFILE SEE SHEETS 19&20

3/16/2017  
R:\Roadway\Proj\13100b\_rdy\_PSH08.dgn  
schneid