

PROJECT REFERENCE NO. <b>R-3100B</b>	SHEET NO. <b>7</b>
R/W SHEET NO.	HYDRAULICS ENGINEER
ROADWAY DESIGN ENGINEER	SEAL 18470
EDWARD GLENN EDWARDS JR.	SEAL 037863
3/16/2017	3/20/2017
DOCUMENT NOT CONSIDERED FINAL UNLESS ALL SIGNATURES COMPLETED	

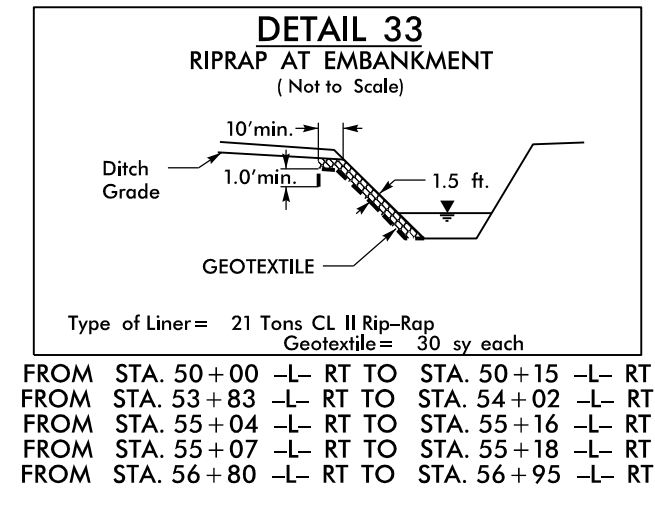

NAD 83 / NRS 2007

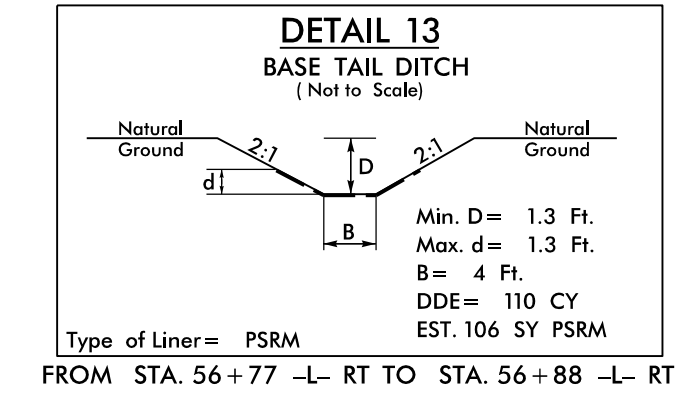
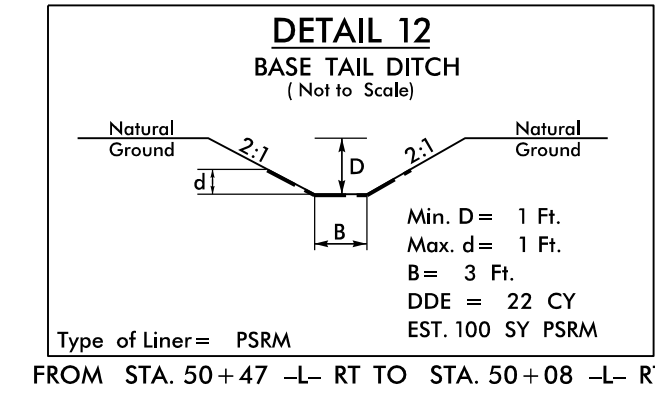
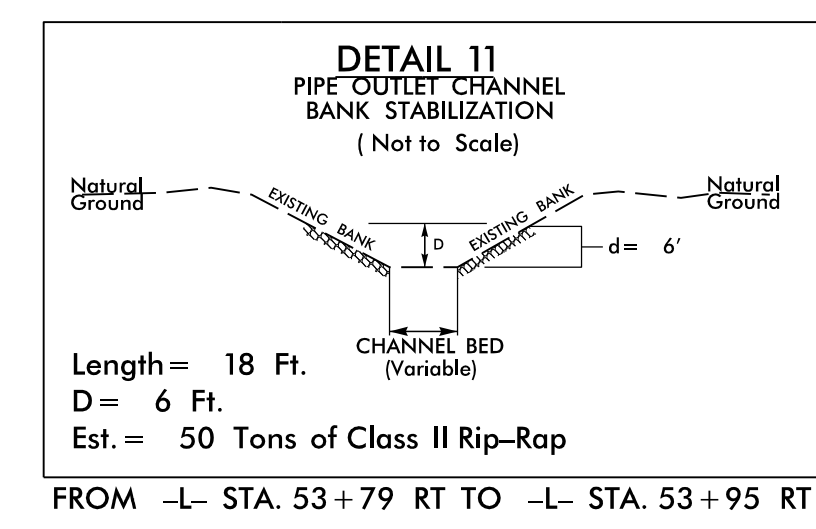
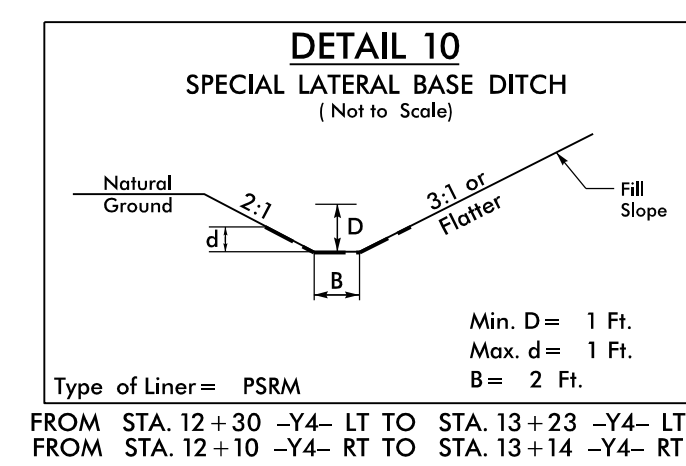
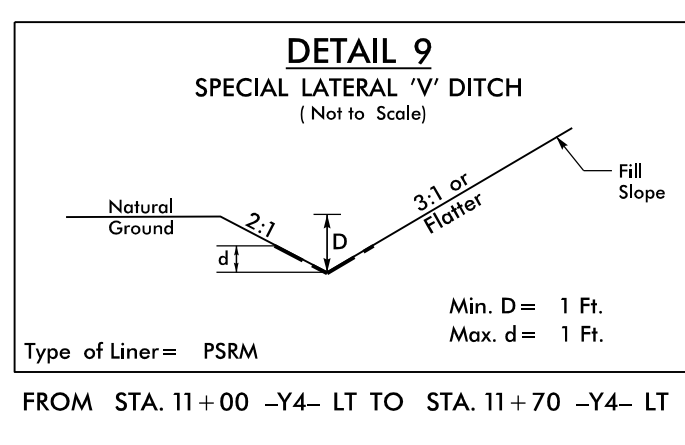
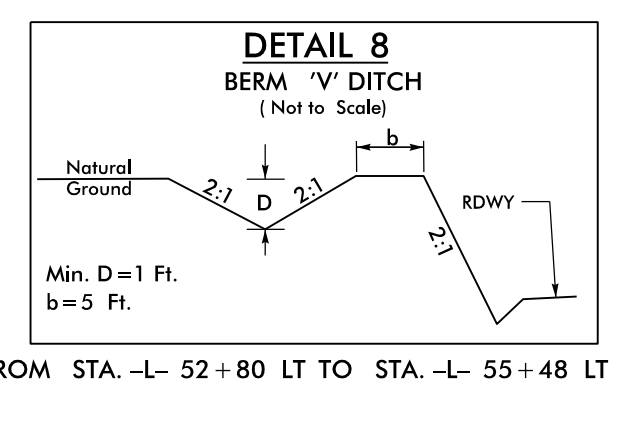
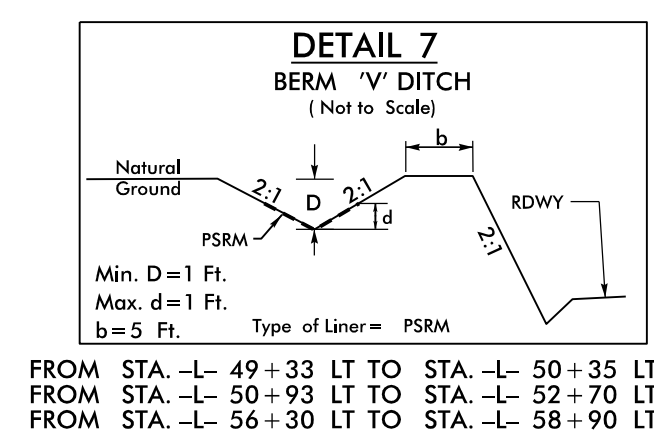
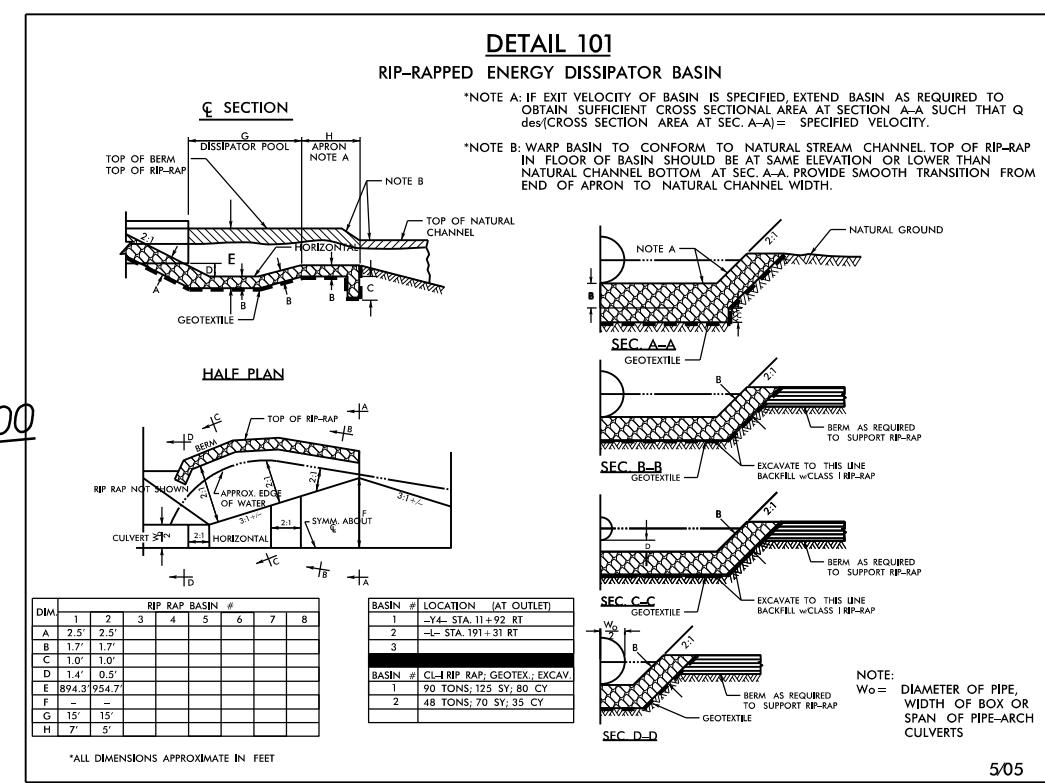
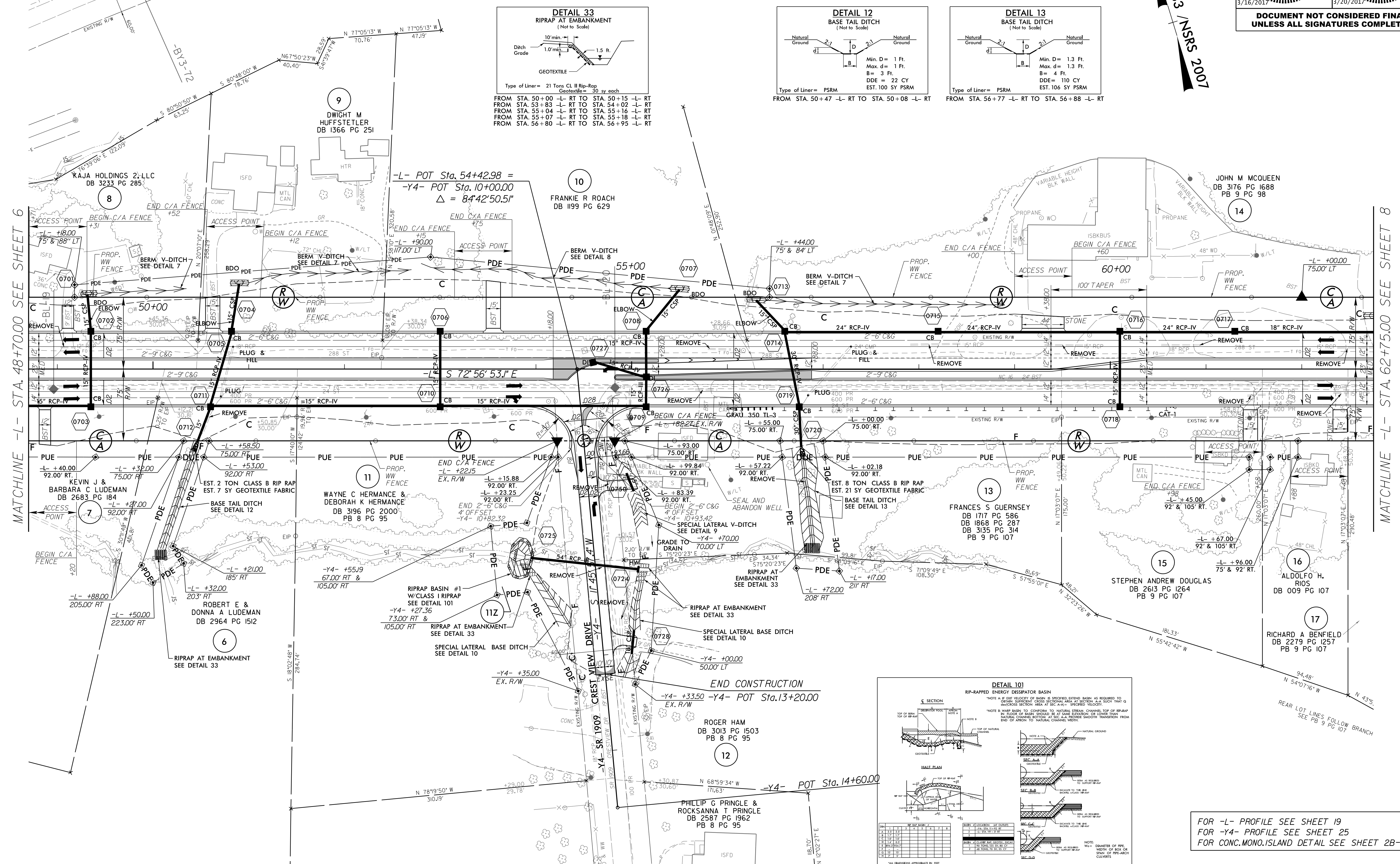

FOR -L- PROFILE SEE SHEET 19  
FOR -Y4- PROFILE SEE SHEET 25  
FOR CONC. MONOISLAND DETAIL SEE SHEET 2B-1

REVISIONS

MATCHLINE -L- STA. 48+70.00 SEE SHEET 6

MATCHLINE -L- STA. 62+75.00 SEE SHEET 8