

8/17/99

Prepared by
URS
URS Corporation - North Carolina
1600 Perimeter Park Drive
Morrisville, North Carolina 27560
TELEPHONE (919) 461-1100 FAX (919) 461-1415
NC LICENSE # C-22943

PROJECT REFERENCE NO. R-3100B	SHEET NO. 6
R/W SHEET NO.	HYDRAULICS ENGINEER
ROADWAY DESIGN ENGINEER	SEAL 18470 EDWARD GLENN EDWARDS JR. 3/16/2017
	SEAL 037863 MEME D. BUSCENI 3/20/2017
DO NOT CONSIDERED FINAL UNLESS ALL SIGNATURES COMPLETED	

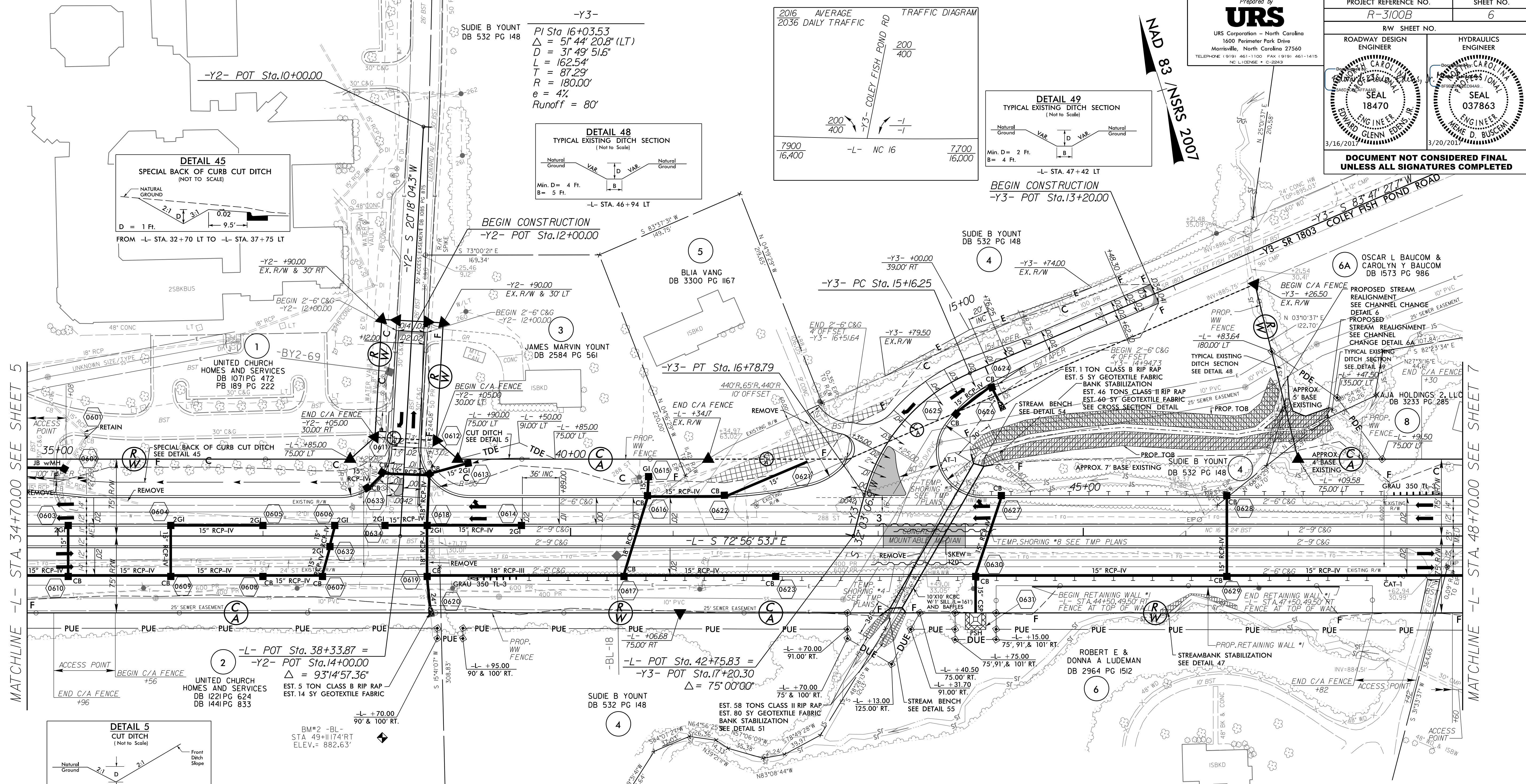
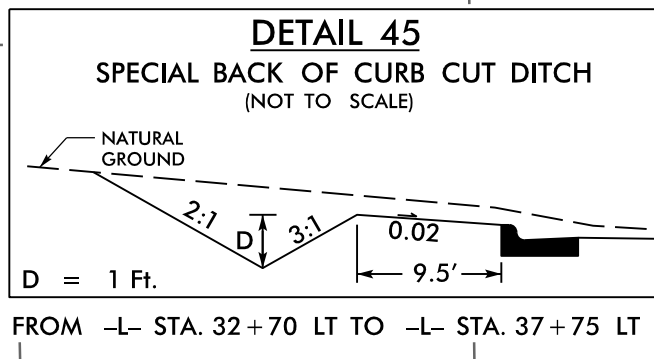
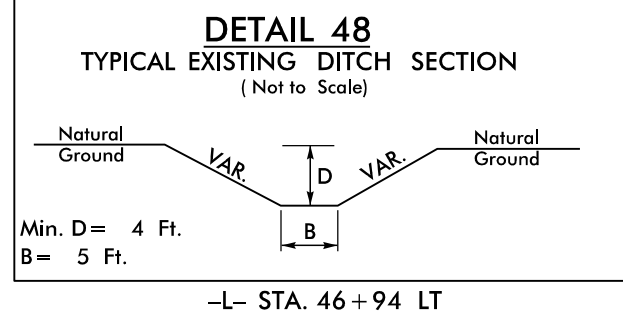
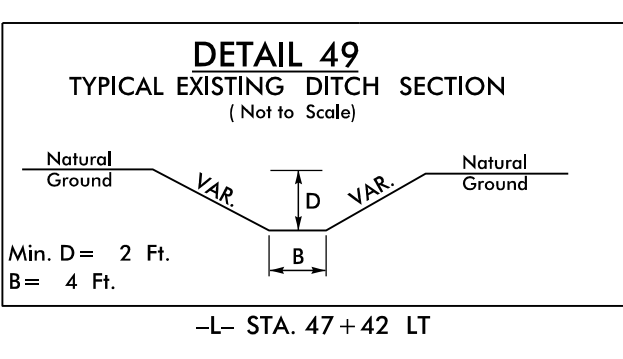
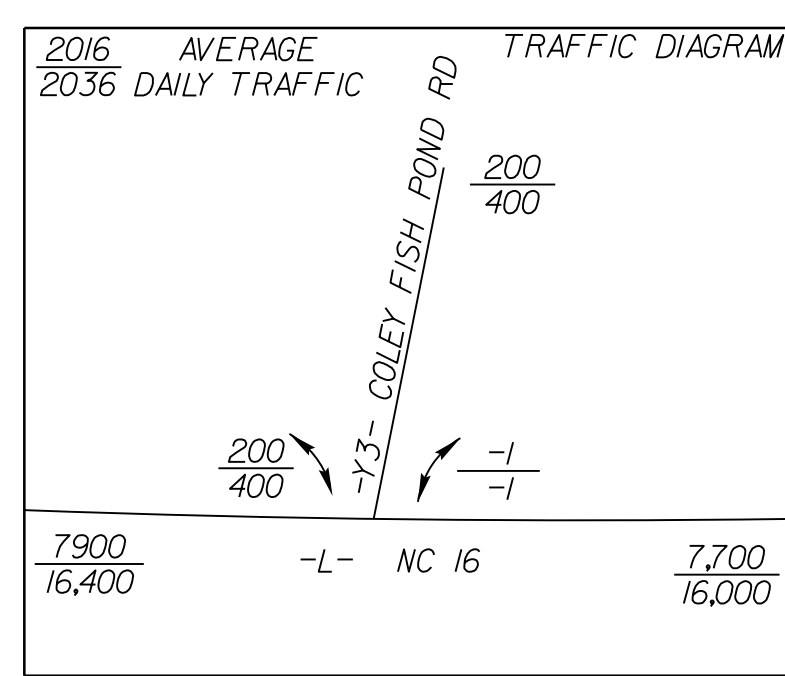

MATCHLINE -L- STA. 34+70.00 SEE SHEET 5

MATCHLINE -L- STA. 48+70.00 SEE SHEET 7

REVISIONS

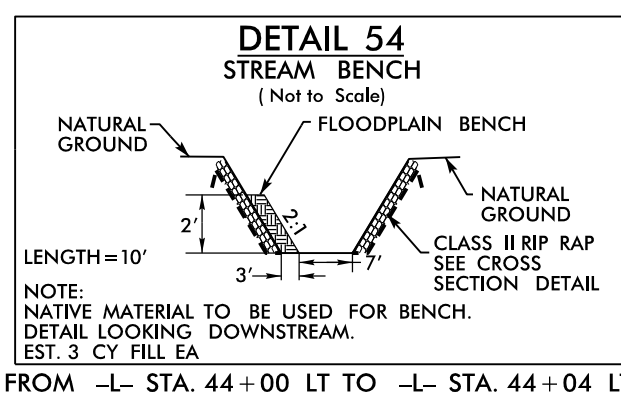
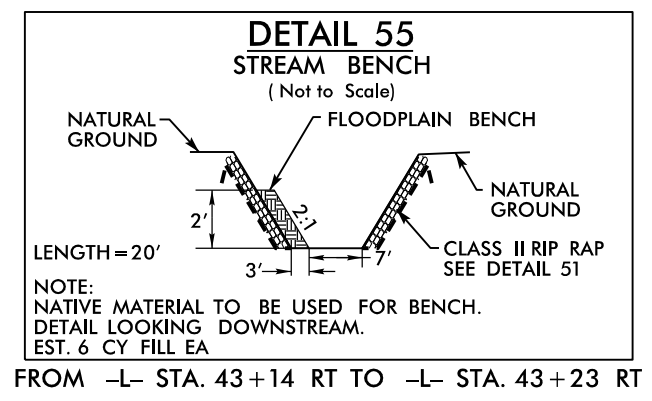
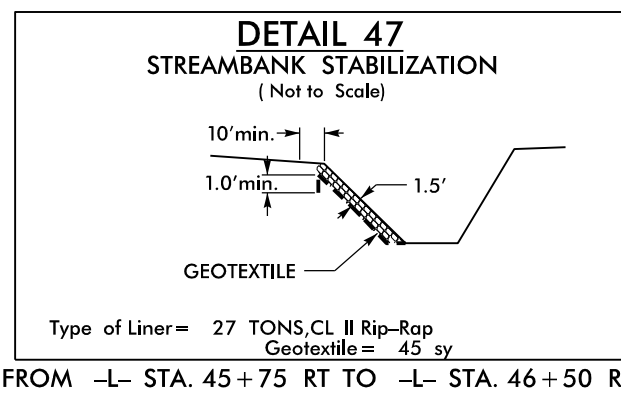
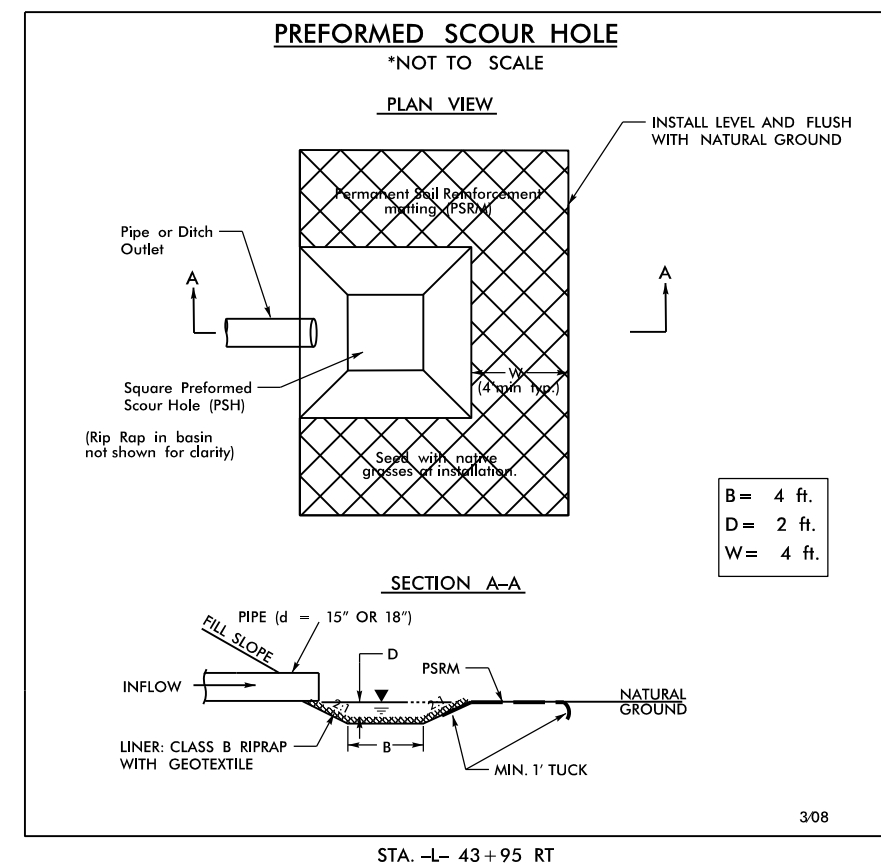
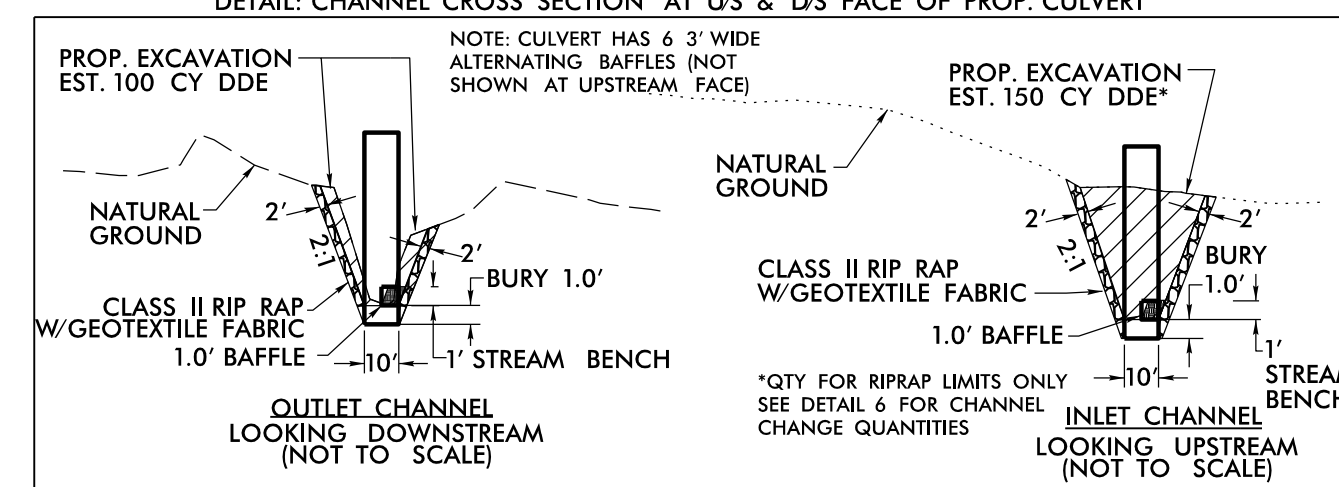
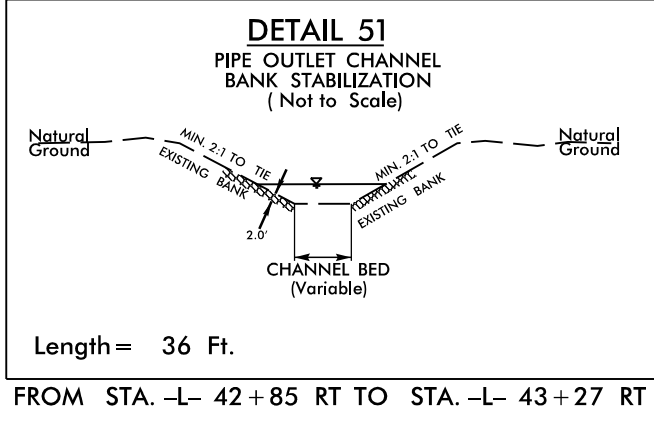
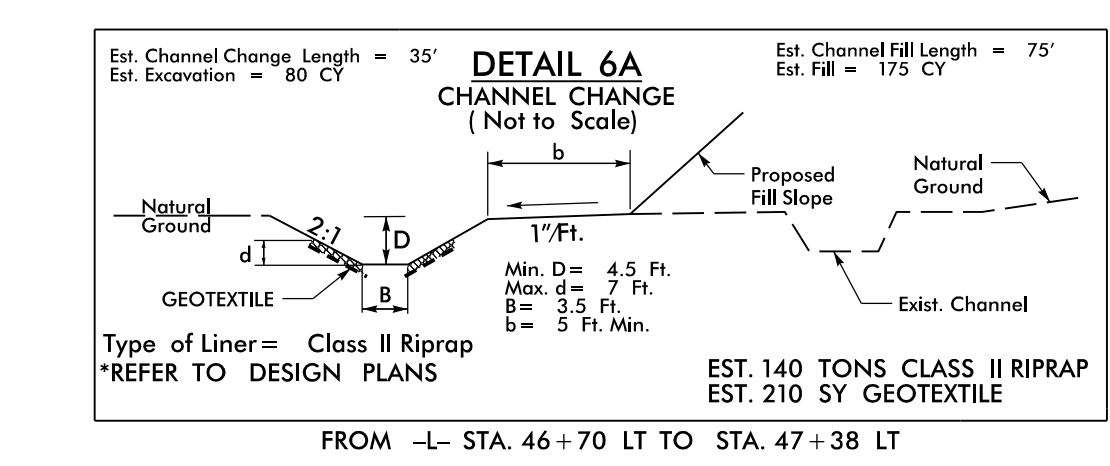
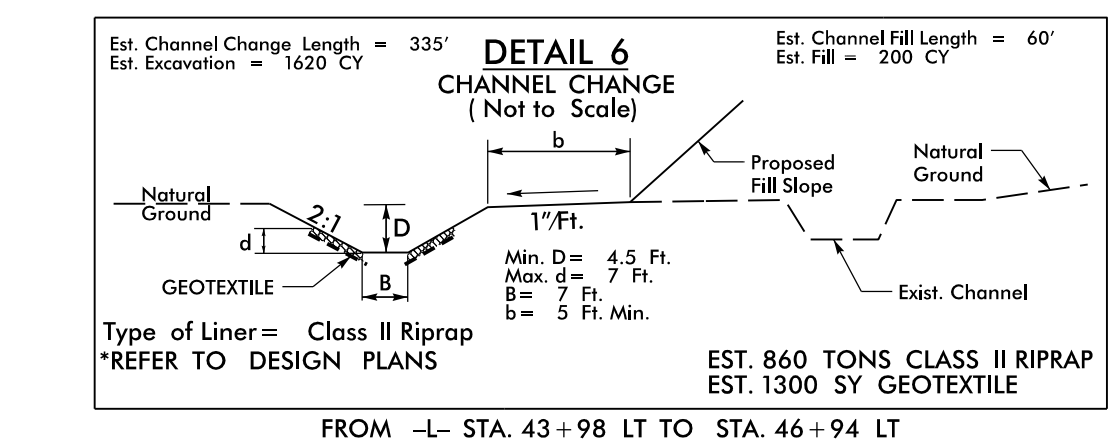
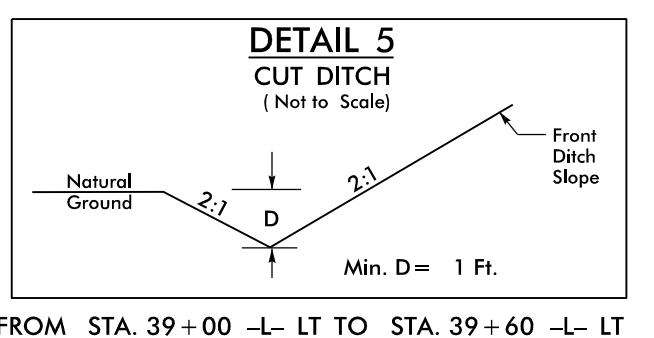

PAVEMENT REMOVAL

FOR -L- PROFILE SEE SHEETS 18&19
 FOR -Y2- PROFILE SEE SHEET 25
 FOR -Y3- PROFILE SEE SHEET 25
 FOR CONC. MOUNTABLE MEDIAN DETAIL SEE SHEET 2B-1
 FOR CULVERT PLANS SEE SHEETS C-27 THRU C-47
 FOR WALL #1 PLANS SEE W-1 THRU W-2
 FOR STREAM CHANNEL CHANGE ALIGNMENT DETAIL SEE SHEET 2D-1

3/16/2017
R:\Roadway\Proj\3100b_rdy_PSH05.dgn
rscheid