

USE FOR LIGHTING CONSTRUCTION ONLY

PRETENSION TO 13,000 POUND-FORCE  
TENSILE FORCE

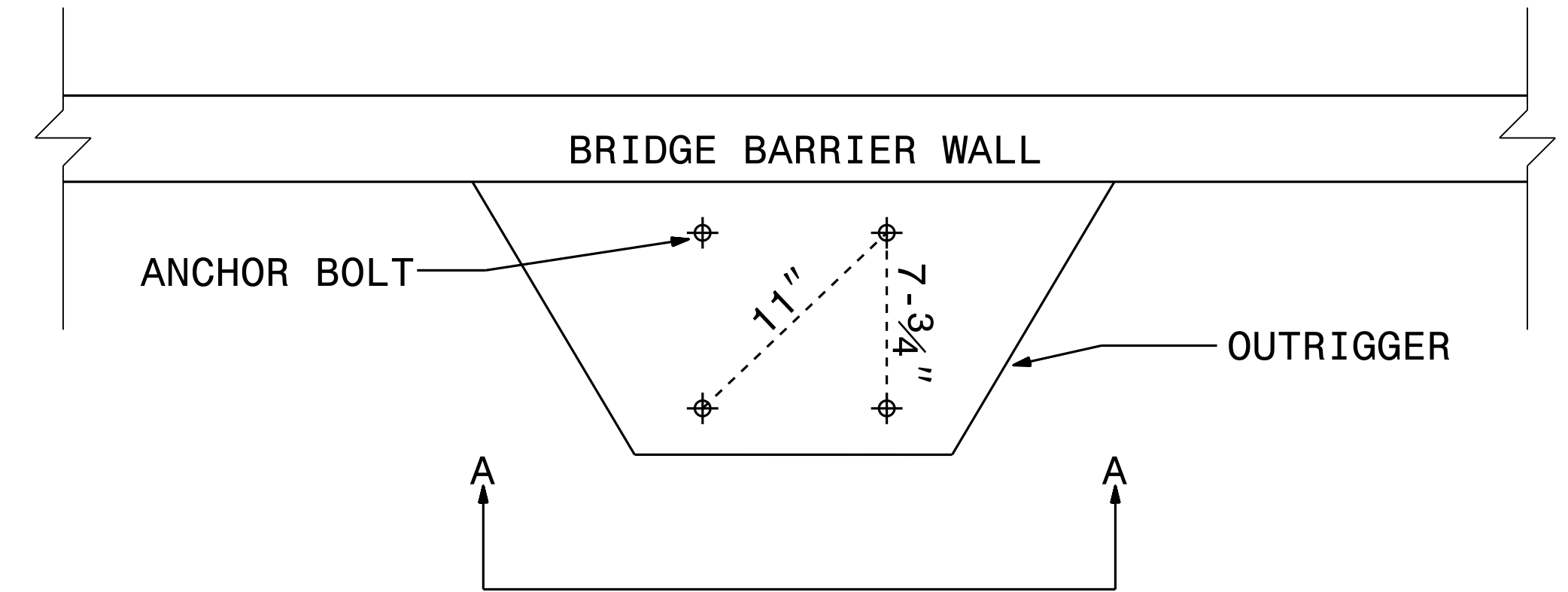
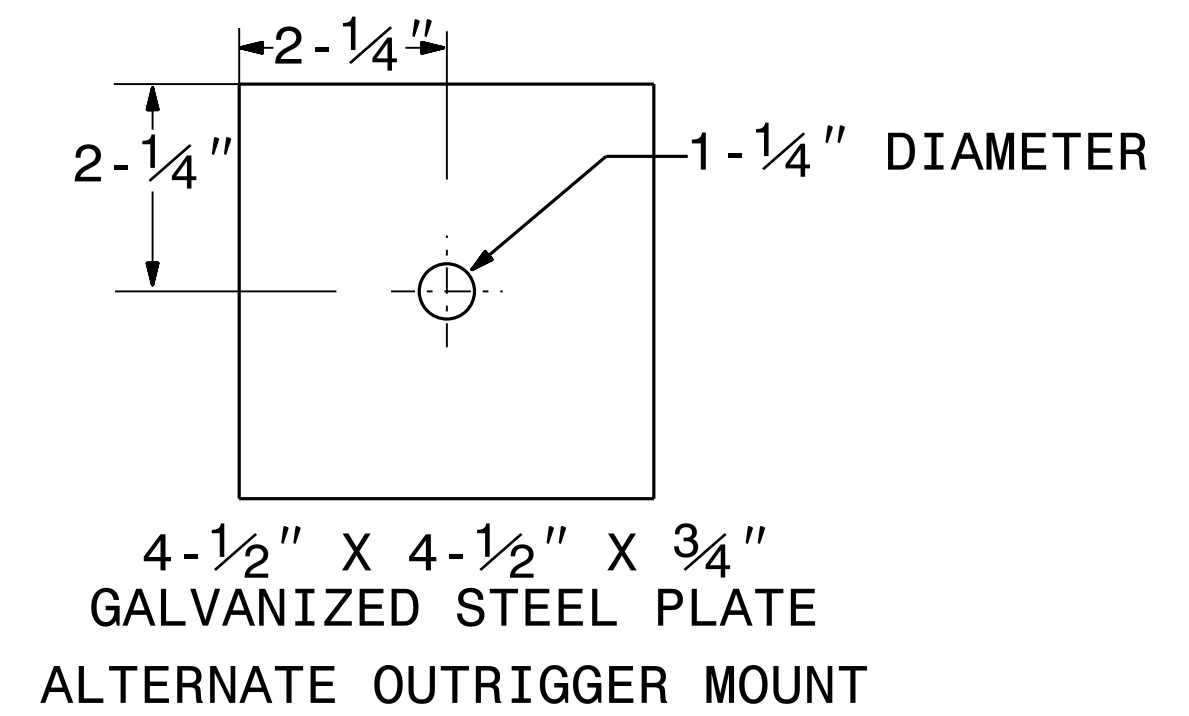
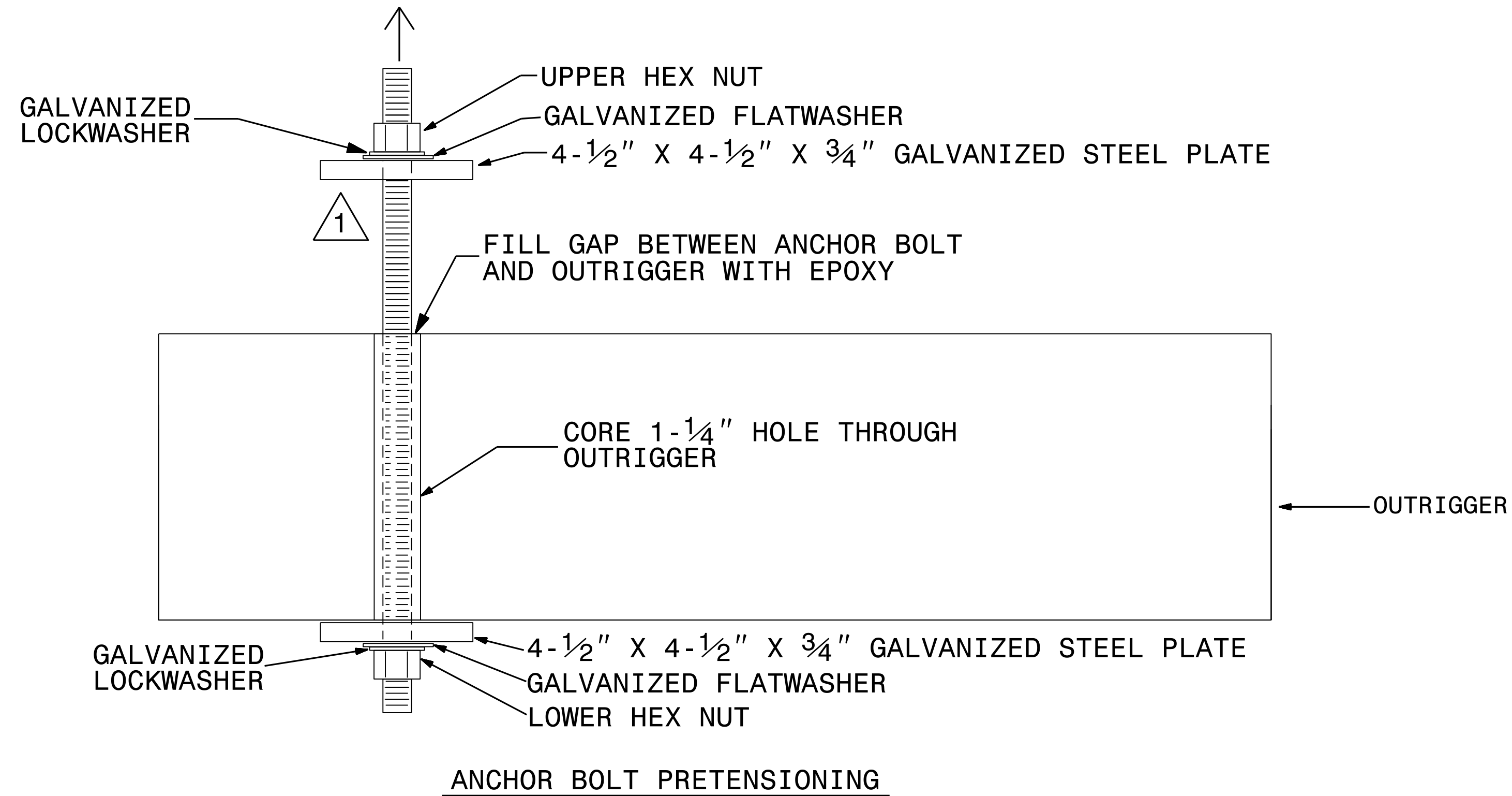

NOTES

- 1 FILL GAP BETWEEN ANCHOR BOLT AND OUTRIGGER WITH EPOXY. PRETENSION ANCHOR BOLT TO 13,000 POUND-FORCE. MAINTAIN FORCE UNTIL BOTH THE UPPER HEX NUT AND THE LOWER HEX NUT ARE TIGHTENED TO A TORQUE OF 270 FT-LBS.

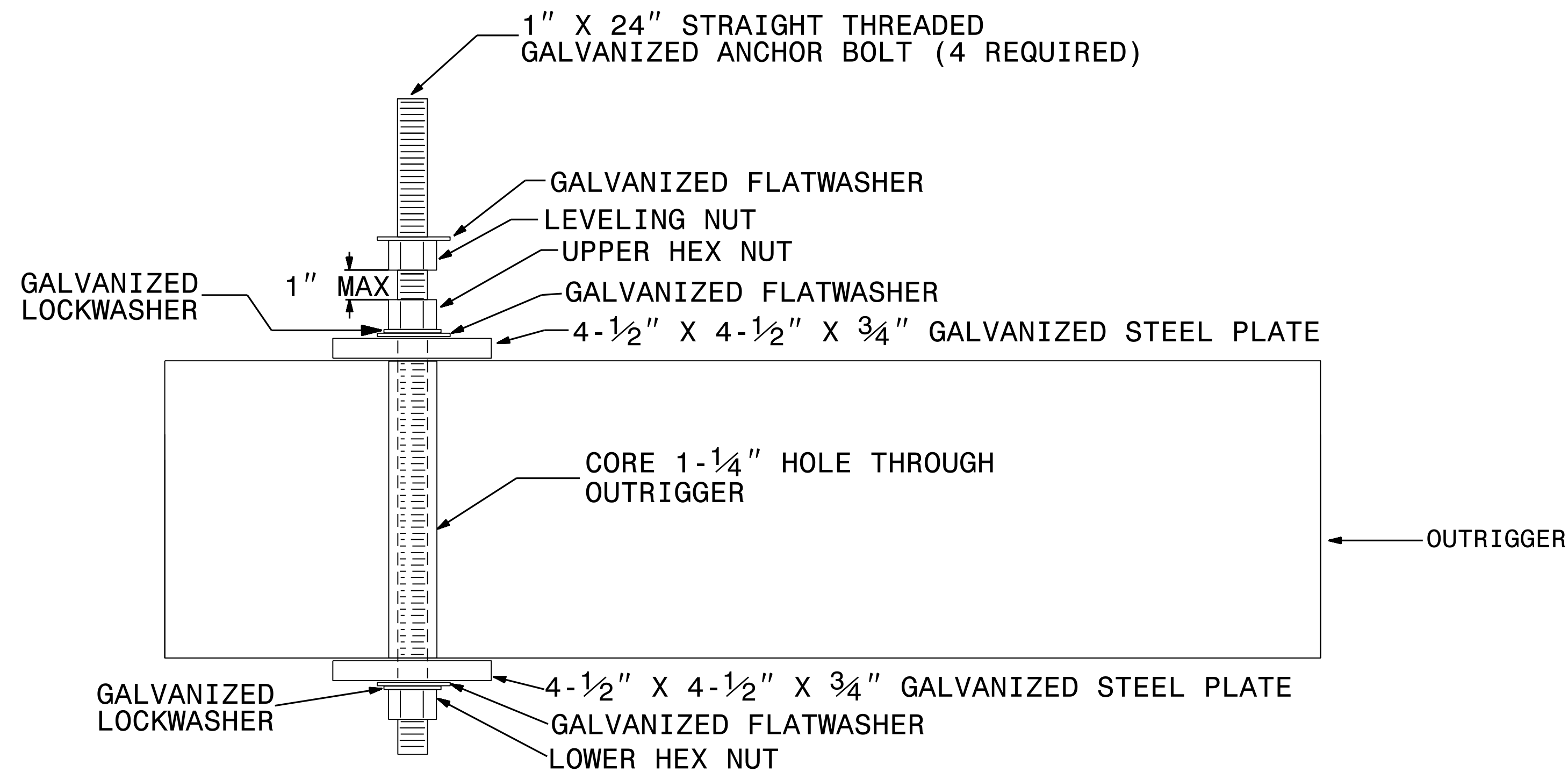

VIEW A-A  
ALTERNATE OUTRIGGER MOUNT  
(ONLY ONE ANCHOR BOLT SHOWN FOR CLARITY)

NTS

PROJECT NO. **B-5938**  
**CARTERET** COUNTY

SHEET 4 OF 6

STATE OF NORTH CAROLINA  
DEPARTMENT OF TRANSPORTATION  
RALEIGH

**LIGHTING DETAILS**  
ALTERNATE OUTRIGGER MOUNTING

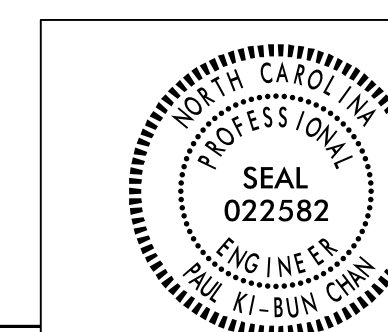

DocuSigned by:  
*Paul Chan*  
1/20/2017

SEE PROJECT SPECIAL PROVISIONS TITLED  
"LIGHTING" FOR MATERIALS  
CONSTRUCTION METHODS AND PAYMENT.

REVISIONS						SHEET NO. L-4
NO.	BY:	DATE:	NO.	BY:	DATE:	
1			3			TOTAL SHEETS 6
2			4			