

TYPICAL MICROWAVE DETECTOR WIRING DETAIL FOR LOOP 2A (wire as shown)

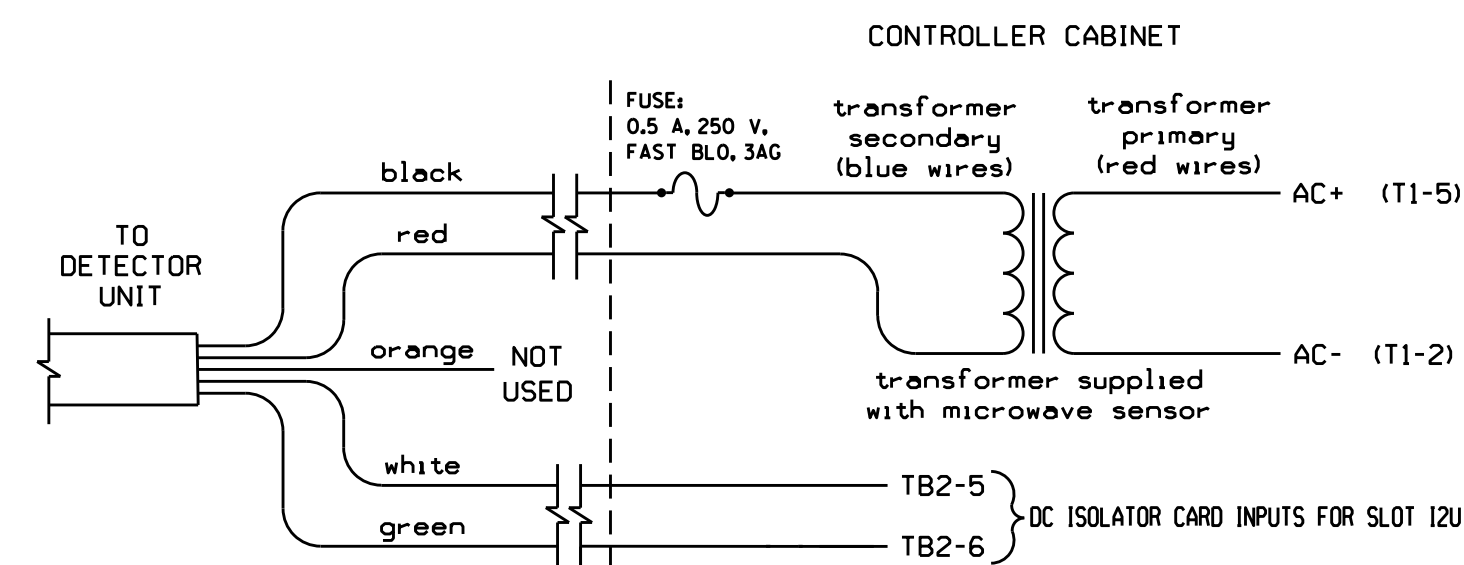

TYPICAL WIRE LIST

COLOR	FUNCTION
black	12V to 24V AC/DC (no polarity)
red	12V to 24V AC/DC (no polarity)
orange	Output Relay Normally Open
white	Output Relay Normally Closed
green	Output Relay Common

NOTES:

- Sensor is a microwave detector mounted on pole as indicated as indicated on the Signal Design Plans.
- Microwave wiring shown above will cause a permanent call unless the Input Assignment Programming and Logical I/O Processor Programming details are entered as shown on this sheet. These programming details will cause a call to be placed upon opening the Normally Closed contact on the microwave detector.
- DC Isolator's LED will be ON when no call is present and will be OFF when a call is present.
- Important: For proper operation of the microwave detector, remove surge protection from TB2-5, TB2-6, TB2-7, and TB2-8 and insert 242 DC Isolator in slot 12.

INPUT ASSIGNMENT PROGRAMMING DETAIL FOR MICROWAVE DETECTOR INPUT

(program controller as shown below)

FROM MAIN MENU PRESS '5' (INPUTS), THEN '+' UNTIL INPUT 1 (PIN 39) IS REACHED. MODIFY DEFAULT CONDITIONS AS INDICATED BY ARROWS.

```

PAGE: 1 C1 PIN:39 NOT ENABLED
INPUT ASSIGNMENT #.....1
DEBOUNCE TIME (0-25.5 SEC).....0.5
DELAY TIME (0-25.5 SEC).....0.0
HOLD-OVER TIME (0-25.5 SEC).....0.0
ASSIGNMENT SELECTION:
NOT ENABLED (Y/N).....Y
VEHICLE DETECTOR (1-64).....
PEDESTRIAN DETECTOR (1-16).....
ALTERNATE PED DETECTOR (1-16).....
PREEMPT (1-10).....
INVERTED PREEMPT (1-10).....
STOP TIME (Y/N).....
FLASH SENSE (Y/N).....
DOOR OPEN (Y/N).....
MANUAL CONTROL ENABLE (Y/N).....
MANUAL CONTROL ADVANCE (Y/N).....
SPECIAL FUNCTION ALARM (1-8).....
TOD HOUR SYNCHRONIZATION (0-23).....
FORCE OFF RING (1-4).....
HOLD PHASES (1-16).....
PLAN (65=FLSH,66=FREE)... OFFSET#...
CHANGE PHASE SEQUENCE PAGE (1-12)...
CHANGE PHASE TIMING PAGE (1-4)...
CHANGE PHASE CONTROL PAGE (1-4)...
CHANGE OVERLAP CONTROL PAGE (1-4)...
CHANGE INPUT PAGE (1-4)...
CHANGE OUTPUT PAGE (1-4)...
OVERRIDE PHASE CONTROL FUNCTION (Y)...
    
```

ENTER 'YES' for Not Enabled

```

PAGE: 1 C1 PIN:0 VEHICLE DETECTOR
INPUT ASSIGNMENT #.....64
DEBOUNCE TIME (0-25.5 SEC).....0.5
DELAY TIME (0-25.5 SEC).....0.0
HOLD-OVER TIME (0-25.5 SEC).....0.0
ASSIGNMENT SELECTION:
NOT ENABLED (Y/N).....
VEHICLE DETECTOR (1-64).....2
PEDESTRIAN DETECTOR (1-16).....
ALTERNATE PED DETECTOR (1-16).....
PREEMPT (1-10).....
INVERTED PREEMPT (1-10).....
STOP TIME (Y/N).....
FLASH SENSE (Y/N).....
DOOR OPEN (Y/N).....
MANUAL CONTROL ENABLE (Y/N).....
MANUAL CONTROL ADVANCE (Y/N).....
SPECIAL FUNCTION ALARM (1-8).....
TOD HOUR SYNCHRONIZATION (0-23).....
FORCE OFF RING (1-4).....
HOLD PHASES (1-16).....
PLAN (65=FLSH,66=FREE)... 65 OFFSET#...
CHANGE PHASE SEQUENCE PAGE (1-12)...
CHANGE PHASE TIMING PAGE (1-4)...
CHANGE PHASE CONTROL PAGE (1-4)...
CHANGE OVERLAP CONTROL PAGE (1-4)...
CHANGE INPUT PAGE (1-4)...
CHANGE OUTPUT PAGE (1-4)...
OVERRIDE PHASE CONTROL FUNCTION (Y)...
    
```

ENTER '2' for Vehicle Detector

PRESS '-' until Input Assignment #64 is reached

PROGRAMMING COMPLETE

NOTE:

This remapping removes the default detector from the microwave's physical input and reassigns it to unused INPUT 64. The Logical I/O Processor Programming Detail on this sheet will invert the disabled input and control INPUT 64 and the reassigned detector.

LOGICAL I/O PROCESSOR PROGRAMMING DETAIL TO INVERT INPUT FROM MICROWAVE DETECTOR

(program controller as shown below)

- From Main Menu press '6' (Outputs), Then '3' (Logical I/O Processor).
- The programming shown below will invert the input from the microwave detector so a call is placed on Detector 2 (INPUT 64) when the Normally Closed output opens up.

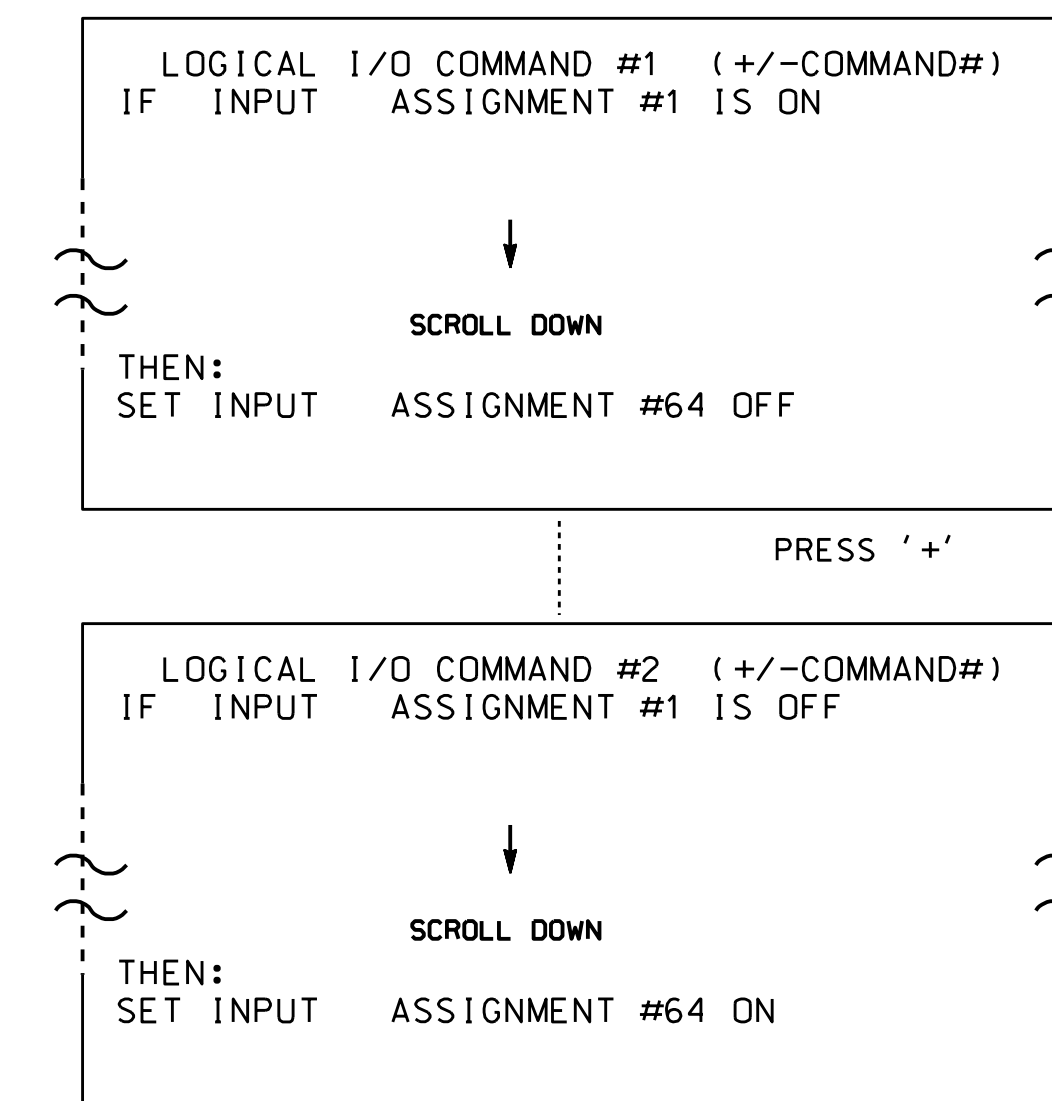

LOGIC I/O PROCESSOR PROGRAMMING COMPLETE

- From Main Menu press '2' (Phase Control), Then '1' (Phase Control Functions). Scroll to the bottom of the menu and enable ACT LOGIC Commands 1 and 2.

REFERENCE SCHEDULE

- * INPUT 1 = Microwave Detector Physical Input (Not Enabled)
- * INPUT 64 = Dummy TC26B Input (Detector 2)

* Input Remapped

THIS ELECTRICAL DETAIL IS FOR THE SIGNAL DESIGN: 13-0893
DESIGNED: February 2016
SEALED: 8-22-16
REVISED: N/A

Electrical Detail - Sheet 2 of 2

DOCUMENT NOT CONSIDERED FINAL UNLESS ALL SIGNATURES COMPLETED

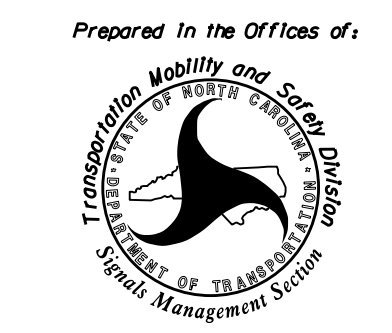
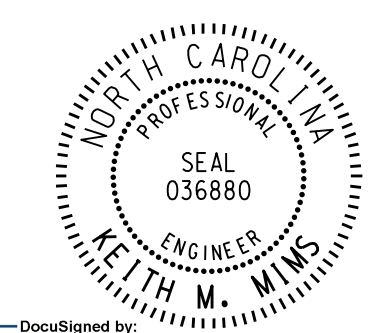
ELECTRICAL AND PROGRAMMING DETAILS FOR: Prepared In the Offices of:  750 N. Greenfield Pkwy, Garner, NC 27529	US 25A (Sweeten Creek Road) at SR 3187 (Pensacola Avenue)		SEAL  KEITH M. MIMS ENGINEER
	Division 18 Buncombe County Asheville PLAN DATE: July 2016 REVIEWED BY: DTJ PREPARED BY: James Peterson REVIEWED BY:	REVISIONS INIT. DATE DocuSigned by: Keith M. Mims 9/16/2016 2F307B82A45E DATE SIG. INVENTORY NO. 13-0893	