

**EDI MODEL 2018EClip-NC CONFLICT MONITOR PROGRAMMING DETAIL**

(remove jumpers and set switches as shown)

REMOVE DIODE JUMPERS 1-5, 1-6, 1-9, 1-11, 1-15, 2-5, 2-6, 2-9, 2-11, 2-13, 2-15, 4-8, 4-14, 4-16, 5-9, 5-11, 5-13, 6-9, 6-11, 6-13, 6-15, 8-14, 8-16, 9-11, 9-13, 9-15, 11-13, 11-15, 13-15, and 14-16.

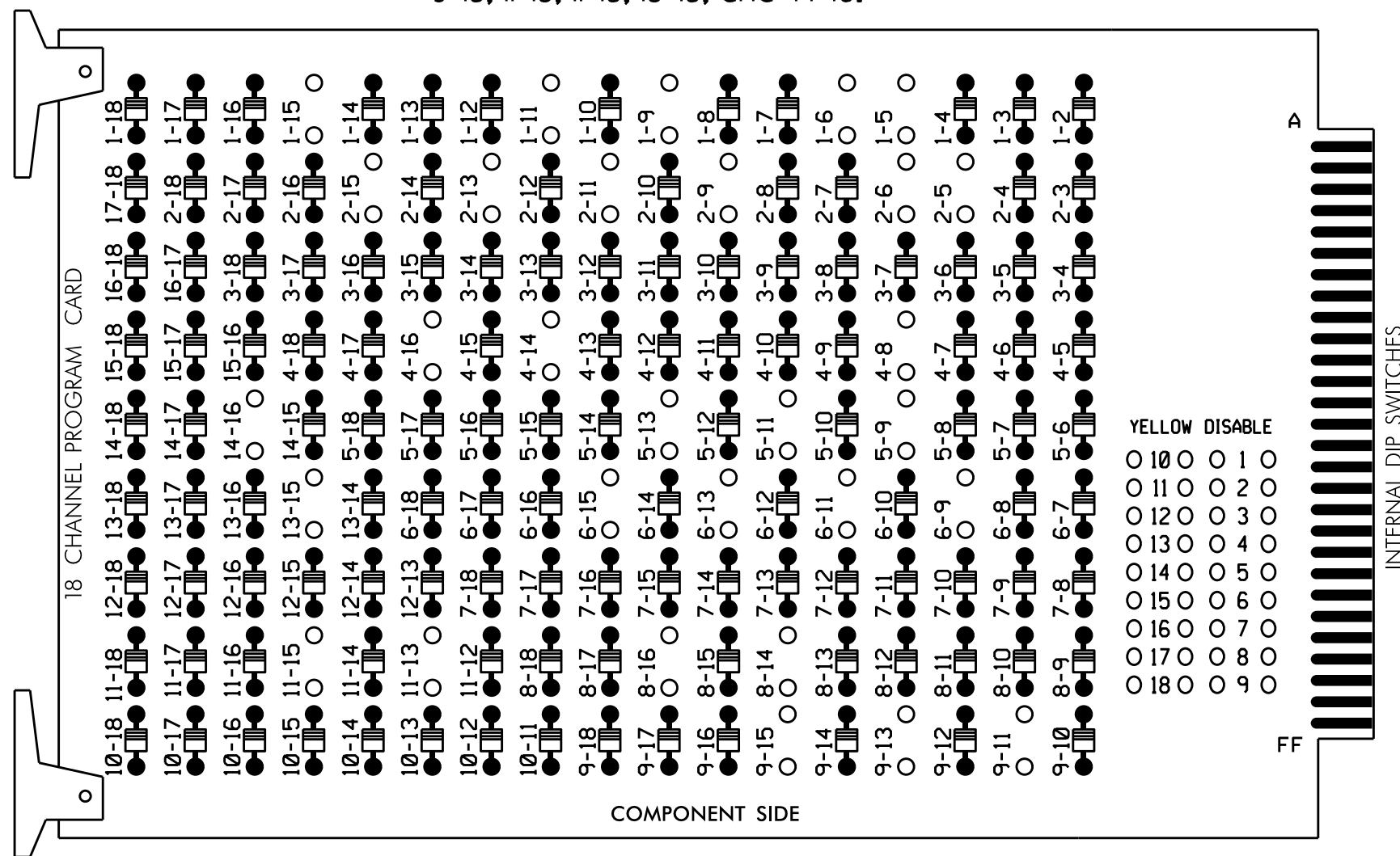

REMOVE JUMPERS AS SHOWN

**NOTES:**

- Card is provided with all diode jumpers in place. Removal of any jumper allows its channels to run concurrently.
- Ensure jumpers SEL2-SEL5 and SEL9 are present on the monitor board.
- Ensure that Red Enable is active at all times during normal operation.
- Integrate monitor with Ethernet network in cabinet.

**NOTES**

- To prevent "flash-conflict" problems, insert red flash program blocks for all unused vehicle load switches in the output file. The installer shall verify that signal heads flash in accordance with the Signal Plans.
- Program phases 4 and 8 for Dual Entry.
- Enable Simultaneous Gap-Out for all phases.
- Program phases 2 and 6 for Variable Initial and Gap Reduction.
- Program phases 2 and 6 for Start Up In Green.
- Program phases 2, 4, 6 and 8 for 'STARTUP PED CALL'.
- Program phases 2 and 6 for Yellow Flash, and overlap 1 as Wag Overlaps.
- The cabinet and controller are part of the Asheville Signal System.

**EQUIPMENT INFORMATION**

CONTROLLER.....2070E  
 CABINET.....332 W/ AUX  
 SOFTWARE.....ECONOLITE OASIS  
 CABINET MOUNT.....BASE  
 OUTPUT FILE POSITIONS...18 WITH AUX. OUTPUT FILE  
 LOAD SWITCHES USED.....S1,S2,S3,S5,S6,S7,S8,S9,S11,S12,  
 AUX S1,AUX S4  
 PHASES USED.....1,2,2PED,4,4PED,5,6,6PED,8,8PED  
 OVERLAP "A".....1+2  
 OVERLAP "B".....NOT USED  
 OVERLAP "C".....5+6  
 OVERLAP "D".....NOT USED

**SIGNAL HEAD HOOK-UP CHART**

LOAD SWITCH NO.	S1	S2	S3	S4	S5	S6	S7	S8	S9	S10	S11	S12	AUX S1	AUX S2	AUX S3	AUX S4	AUX S5	AUX S6
CMU CHANNEL NO.	1	2	13	3	4	14	5	6	15	7	8	16	9	10	17	11	12	18
PHASE	1	2	2 PED	3	4	4 PED	5	6	6 PED	7	8	8 PED	OLA	OLB	SPARE	OLC	OLD	SPARE
SIGNAL HEAD NO.	11	21,22	P21, P22	NU	41,42	P41, P42	51	61,62	P61, P62	NU	81,82	P81, P82	11	NU	NU	51	NU	NU
RED		128			101			134			107							
YELLOW	*	129			102		*	135			108							
GREEN		130			103			136			109							
RED ARROW													A121				A114	
YELLOW ARROW													A122				A115	
FLASHING YELLOW ARROW													A123				A116	
GREEN ARROW	127							133										
Hand			113			104			119			110						
Person			115			106			121			112						

NU = Not Used  
 \* Denotes install load resistor. See load resistor installation detail this sheet.  
 ★ See pictorial of head wiring in detail below.

**INPUT FILE POSITION LAYOUT**

(front view)

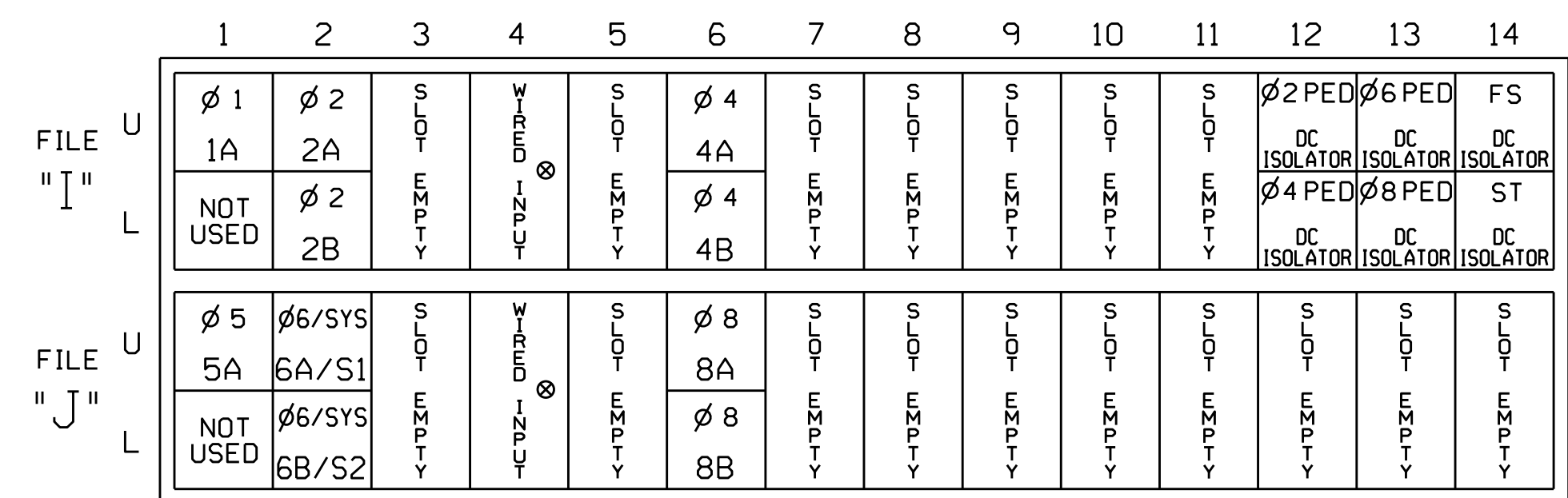

EX.: 1A, 2A, ETC. = LOOP NO.'S  
 FS = FLASH SENSE  
 ST = STOP TIME  
 ⊗ Wired Input - Do not populate slot with detector card

**INPUT FILE CONNECTION & PROGRAMMING CHART**

LOOP NO.	LOOP TERMINAL	INPUT FILE POS.	PIN NO.	INPUT ASSIGNMENT NO.	DETECTOR NO.	NEMA PHASE	CALL	EXTEND	FULL TIME DELAY	STRETCH TIME	DELAY TIME
1A <sup>1</sup>	TB2-1,2	I1U	56	18	1	1	Y	Y			15
	-	J4U	48	10	26	6	Y	Y	Y		3
2A	TB2-5,6	I2U	39	1	2	2	Y	Y			
2B	TB2-7,8	I2L	43	5	12	2	Y	Y			
4A	TB4-9,10	I6U	41	3	4	4	Y	Y			3
4B	TB4-11,12	I6L	45	7	14	4	Y	Y			10
5A <sup>2</sup>	TB3-1,2	J1U	55	17	5	5	Y	Y			15
	-	I4U	47	9	22	2	Y	Y	Y		3
6A/S1	TB3-5,6	J2U	40	2	6	6/SYS	Y	Y			
6B/S2	TB3-7,8	J2L	44	6	16	6/SYS	Y	Y			
8A	TB5-9,10	J6U	42	4	8	8	Y	Y			
8B	TB5-11,12	J6L	46	8	18	8	Y	Y			10
PED PUSH BUTTONS											
P21,P22	TB8-4,6	I12U	67	29	PED 2	2 PED					
P41,P42	TB8-5,6	I12L	69	31	PED 4	4 PED					
P61,P62	TB8-7,9	I13U	68	30	PED 6	6 PED					
P81,P82	TB8-8,9	I13L	70	32	PED 8	8 PED					

NOTE:  
 INSTALL DC ISOLATORS IN INPUT FILE SLOTS 112 AND 113.

- Add jumper from I1-W to J4-W. on rear of input file.
- Add jumper from J1-W to I4-W. on rear of input file.

**INPUT FILE POSITION LEGEND: J2L**

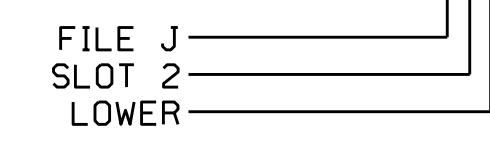

**FYA SIGNAL WIRING DETAIL**

(wire signal heads as shown)

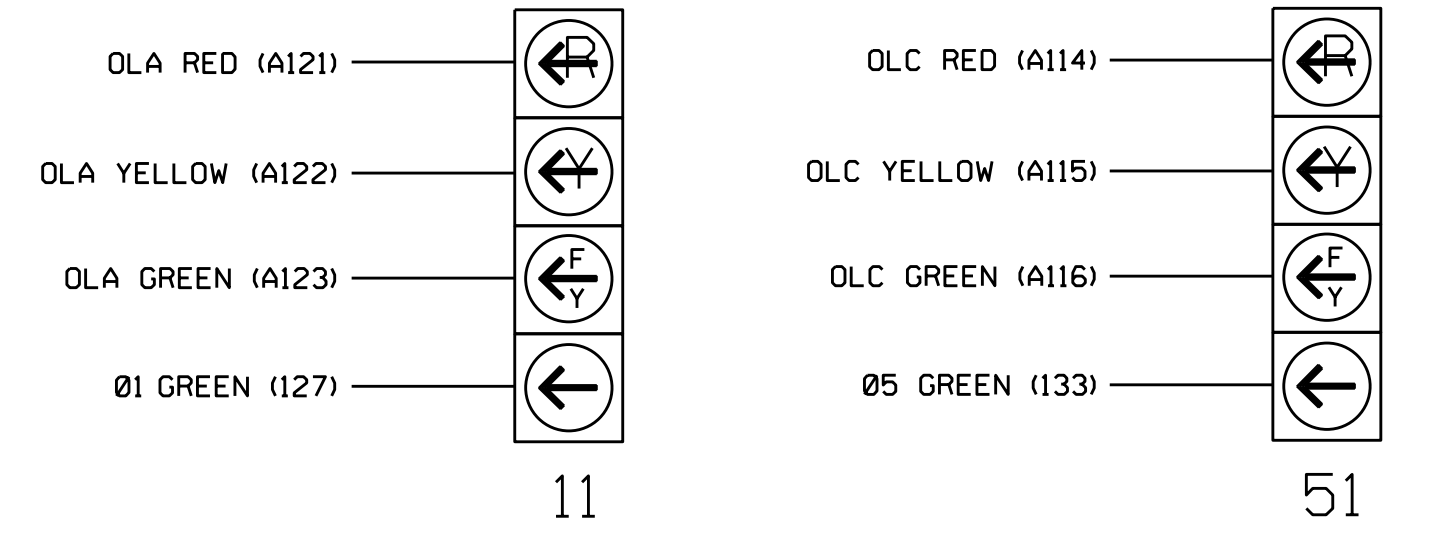

**NOTE**

The sequence display for signal heads 11 and 51 requires special logic programming. See sheet 2 for programming instructions.

THIS ELECTRICAL DETAIL IS FOR THE SIGNAL DESIGN: 13-0508  
 DESIGNED: February 2016  
 SEALED: 8/18/2016  
 REVISED: N/A

**LOAD RESISTOR INSTALLATION DETAIL**

(install resistors as shown below)

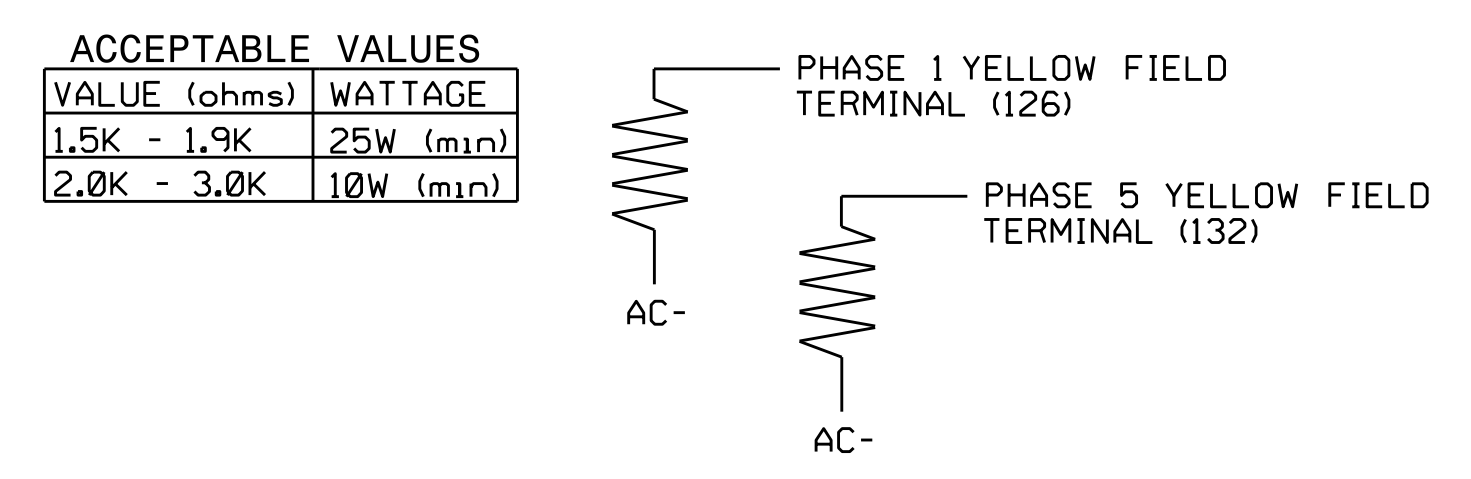

Electrical Detail - Sheet 1 of 2

DOCUMENT NOT CONSIDERED FINAL UNLESS ALL SIGNATURES COMPLETED

Prepared In the Offices of:  
 TRANSPORTATION MOBILITY AND SAFETY DIVISION  
 NORTH CAROLINA DEPARTMENT OF TRANSPORTATION  
 Signal Management Section

US 25 (Hendersonville Rd) at Turtle Creek Dr/ Weirbridge Village Entrance

Division 13 Buncombe County Asheville

PLAN DATE: July 2016 REVIEWED BY: BAS  
 PREPARED BY: S. Armstrong REVIEWED BY:

REVISIONS INIT. DATE

DocuSigned by:  
 Keith M. Mims 9/12/2016  
 2F807866C0D3445 DATE

750 N. Greenfield Pkwy, Garner, NC 27529

SIG. INVENTORY NO. 13-0508