

EDI MODEL 2018EClip-NC CONFLICT MONITOR

PROGRAMMING DETAIL

(remove jumpers and set switches as shown)

REMOVE DIODE JUMPERS 2-5, 2-6, 2-9, 2-11, 2-15, 4-8, 4-16, 5-9, 5-11, 6-9, 6-11, 6-15, 8-16, 9-11, 9-15 and 11-15.

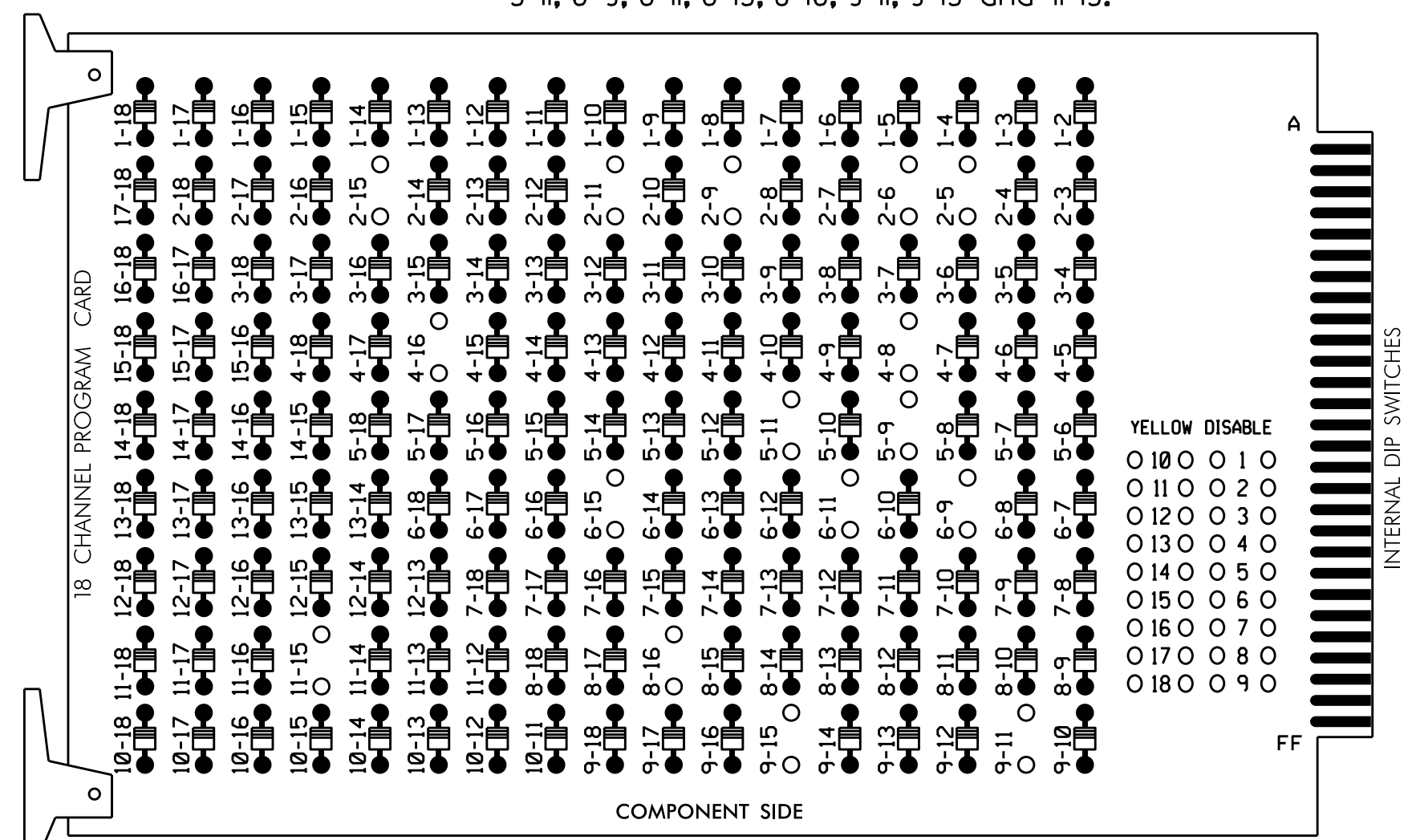

REMOVE JUMPERS AS SHOWN

NOTES:

- Card is provided with all diode jumpers in place. Removal of any jumper allows its channels to run concurrently.
- Ensure jumpers SEL2-SEL5 and SEL9 are present on the monitor board.
- Ensure that Red Enable is active at all times during normal operation.
- Integrate monitor with Ethernet network in cabinet.

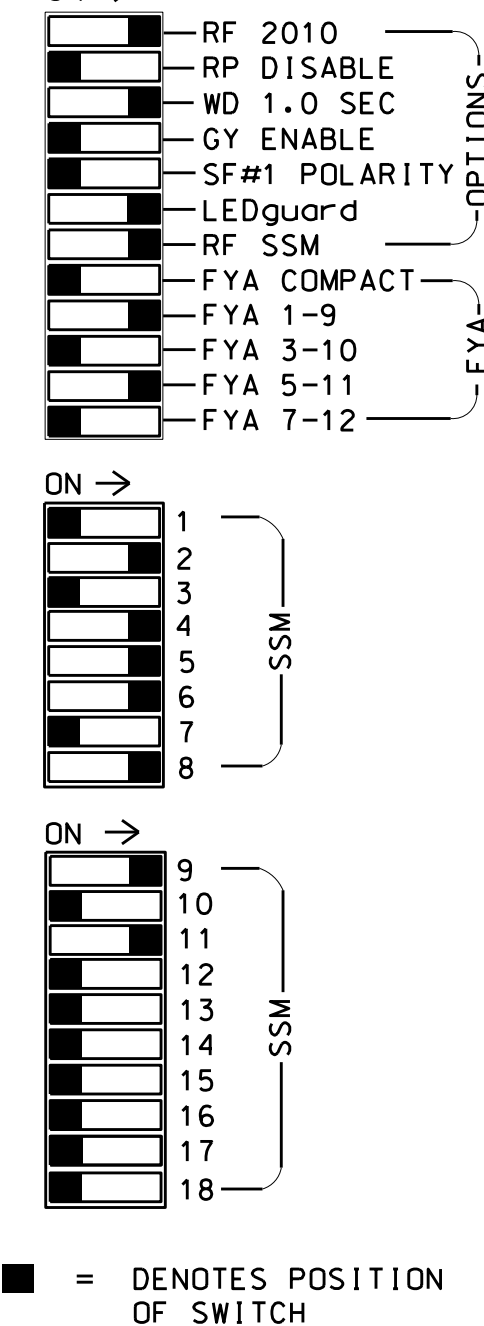

NOTES

- To prevent "flash-conflict" problems, insert red flash program blocks for all unused vehicle load switches in the output file. The installer shall verify that signal heads flash in accordance with the Signal Plans.
- Program phases 4 and 8 for Dual Entry.
- Enable Simultaneous Gap-Out for all phases.
- Program phases 2 and 6 for Variable Initial and Gap Reduction.
- Program phases 2 and 6 for Start Up In Green.
- Program phases 6 and 8 for 'STARTUP PED CALL'.
- Program phases 2 and 6 for Yellow Flash, and overlap 1 as Wag Overlaps.
- The cabinet and controller are part of the Asheville Signal System.

EQUIPMENT INFORMATION

CONTROLLER.....2070E  
 CABINET.....332 W/ AUX  
 SOFTWARE.....ECONOLITE OASIS  
 CABINET MOUNT.....BASE  
 OUTPUT FILE POSITIONS...18 WITH AUX. OUTPUT FILE  
 LOAD SWITCHES USED.....S2,S5,S7,S8,S9,S11,S12,  
 AUX S1,AUX S4  
 PHASES USED.....2,4,5,6,6 PED,8,8 PED  
 OVERLAP "A".....2  
 OVERLAP "B".....NOT USED  
 OVERLAP "C".....5+6  
 OVERLAP "D".....NOT USED

SIGNAL HEAD HOOK-UP CHART

LOAD SWITCH NO.	S1	S2	S3	S4	S5	S6	S7	S8	S9	S10	S11	S12	AUX S1	AUX S2	AUX S3	AUX S4	AUX S5	AUX S6
CMU CHANNEL NO.	1	2	13	3	4	14	5	6	15	7	8	16	9	10	17	11	12	18
PHASE	1	2	2 PED	3	4	4 PED	5	6	6 PED	7	8	8 PED	OLA	OLB	SPARE	OLC	OLD	SPARE
SIGNAL HEAD NO.	NU	21,22	NU	NU	41,42, 43	NU	43	51	62,63	P61, P62	NU	81,82, 83	P81, P82	61	NU	NU	51	NU
RED		128			101		*		134			107						
YELLOW		129			102				135			108						
GREEN		130			103				136			109						
RED ARROW													A121				A114	
YELLOW ARROW								132					A122				A115	
FLASHING YELLOW ARROW													A123				A116	
GREEN ARROW							133	133										
Hand icon										119		110						
Walking person icon																		

NU = Not Used

\* Denotes install load resistor. See load resistor installation detail this sheet.

★ See pictorial of head wiring in detail below.

INPUT FILE POSITION LAYOUT

(front view)

FILE "I"	1	2	3	4	5	6	7	8	9	10	11	12	13	14
U	∅ 2	2A	∅ 2	∅ 2	∅ 4	4A	∅ 4	∅ 4	∅ 4	∅ 4	∅ 4	∅ 4	∅ 4	∅ 4
L	∅ 2	2B	∅ 2	∅ 2	∅ 4	4A	∅ 4	∅ 4	∅ 4	∅ 4	∅ 4	∅ 4	∅ 4	∅ 4
U	∅ 5	5A	∅ 5	∅ 6	∅ 8	8A	∅ 8	∅ 8	∅ 8	∅ 8	∅ 8	∅ 8	∅ 8	∅ 8
L	∅ 5	5B	∅ 6	∅ 6	∅ 8	8A	∅ 8	∅ 8	∅ 8	∅ 8	∅ 8	∅ 8	∅ 8	∅ 8

EX.: 1A, 2A, ETC. = LOOP NO.'S

FS = FLASH SENSE  
 ST = STOP TIME

⊗ Wired Input - Do not populate slot with detector card

INPUT FILE CONNECTION & PROGRAMMING CHART

LOOP NO.	LOOP TERMINAL	INPUT FILE POS.	PIN NO.	INPUT ASSIGNMENT NO.	DETECTOR NO.	NEMA PHASE	CALL	EXTEND	FULL TIME DELAY	STRETCH TIME	DELAY TIME
2A	TB2-5,6	I2U	39	1	2	2	Y	Y			
2B	TB2-7,8	I2L	43	5	12	2	Y	Y			
4A	TB4-9,10	I6U	41	3	4	4	Y	Y			3
* S1	TB6-9,10	I9U	60	22	11	SYS					
* S2	TB6-11,12	I9L	62	24	13	SYS					
5A <sup>1</sup>	TB3-1,2	J1U	55	17	5	5	Y	Y			15
		I4U	47	9	22	2	Y	Y	Y		3
5B	TB3-5,6	J2U	40	2	6	5	Y	Y			15
6A	TB3-7,8	J2L	44	6	16	6	Y	Y			
6B	TB3-9,10	J3U	64	26	36	6	Y	Y			
6C	TB3-11,12	J3L	77	39	46	6	Y	Y	Y		3
8A	TB5-9,10	J6U	42	4	8	8	Y	Y			3
8B	TB5-11,12	J6L	46	8	18	8	Y	Y			10
* S3	TB7-9,10	J9U	59	21	15	SYS					
* S4	TB7-11,12	J9L	61	23	17	SYS					
PED PUSH BUTTONS											
P61,P62	TB8-7,9	I13U	68	30	PED 6	6 PED					
P81,P82	TB8-8,9	I13L	70	32	PED 8	8 PED					

NOTE:  
 INSTALL DC ISOLATOR IN INPUT FILE SLOT I13.

<sup>1</sup>Add jumper from J1-W to I4-W, on rear of input file.

\* System detector only. Remove the vehicle phase assigned to this detector in the default programming.

FYA SIGNAL WIRING DETAIL

(wire signal heads as shown)

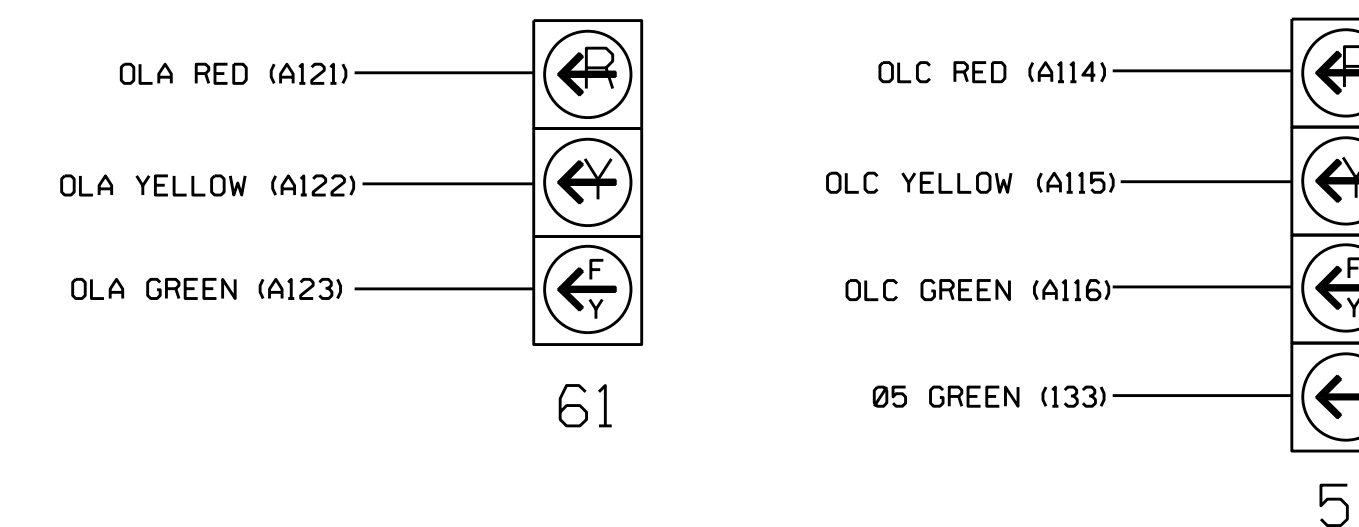

NOTE

1. The sequence display for signal head 51 requires special logic programming. See sheet 2 of 2 for programming instructions.

COUNTDOWN PEDESTRIAN SIGNAL OPERATION

Countdown Ped Signals are required to display timing only during Ped Clearance Interval. Consult Ped Signal Module user's manual for instructions on selecting this feature.

THIS ELECTRICAL DETAIL IS FOR THE SIGNAL DESIGN: 13-0444  
 DESIGNED: June 2016  
 SEALED: 9/19/2016  
 REVISED:

LOAD RESISTOR INSTALLATION DETAIL

(install resistors as shown below)

VALUE (ohms)	WATTAGE
1.5K - 1.9K	25W (min)
2.0K - 3.0K	10W (min)

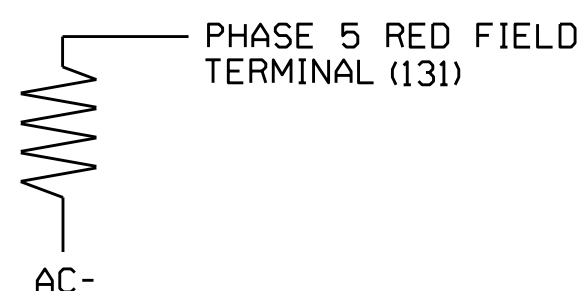

INPUT FILE POSITION LEGEND: J2L

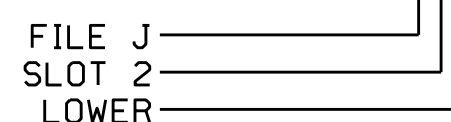

Electrical Detail Sheet 1 of 2

DOCUMENT NOT CONSIDERED FINAL UNLESS ALL SIGNATURES COMPLETED

Electrical and Programming Details for: NC 146 (Long Shoals Road) at SR 3503 (Overlook Road)

Prepared in the Offices of: Transportation Mobility and Safety Solutions, North Carolina State University, Raleigh, NC

750 N. Greenfield Pkwy, Garner, NC 27529

Division 13 Buncombe County Asheville

PLAN DATE: August 2016 REVIEWED BY: K.M. Mims  
 PREPARED BY: Z.M. Little REVIEWED BY:

REVISIONS INIT. DATE

DocuSigned by: Keith M. Mims 10/31/2016

SEAL: KEITH M. MIMS, ENGINEER, 036880

SIG. INVENTORY NO. 13-0444