

EDI MODEL 2018EClip-NC CONFLICT MONITOR PROGRAMMING DETAIL
(remove jumpers and set switches as shown)

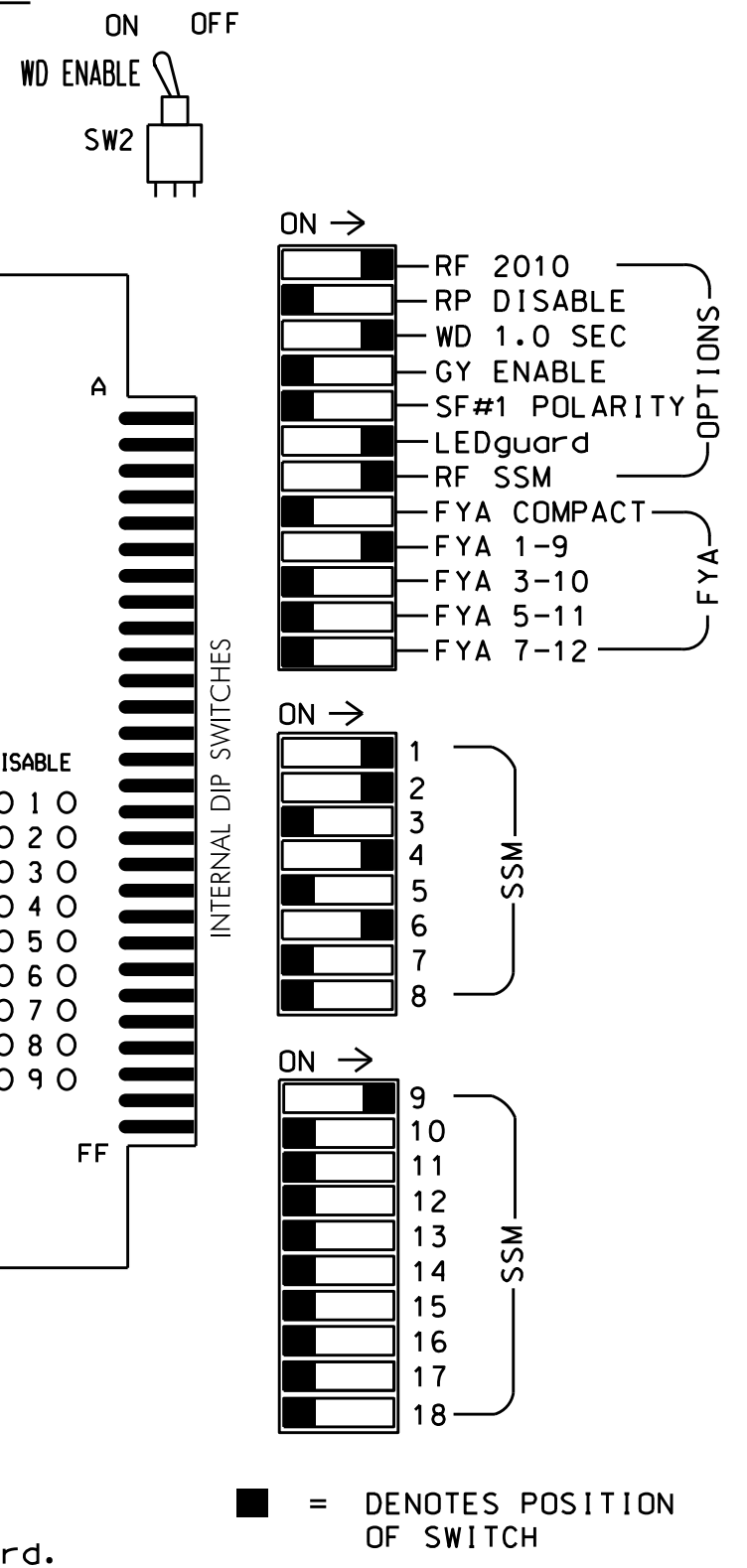
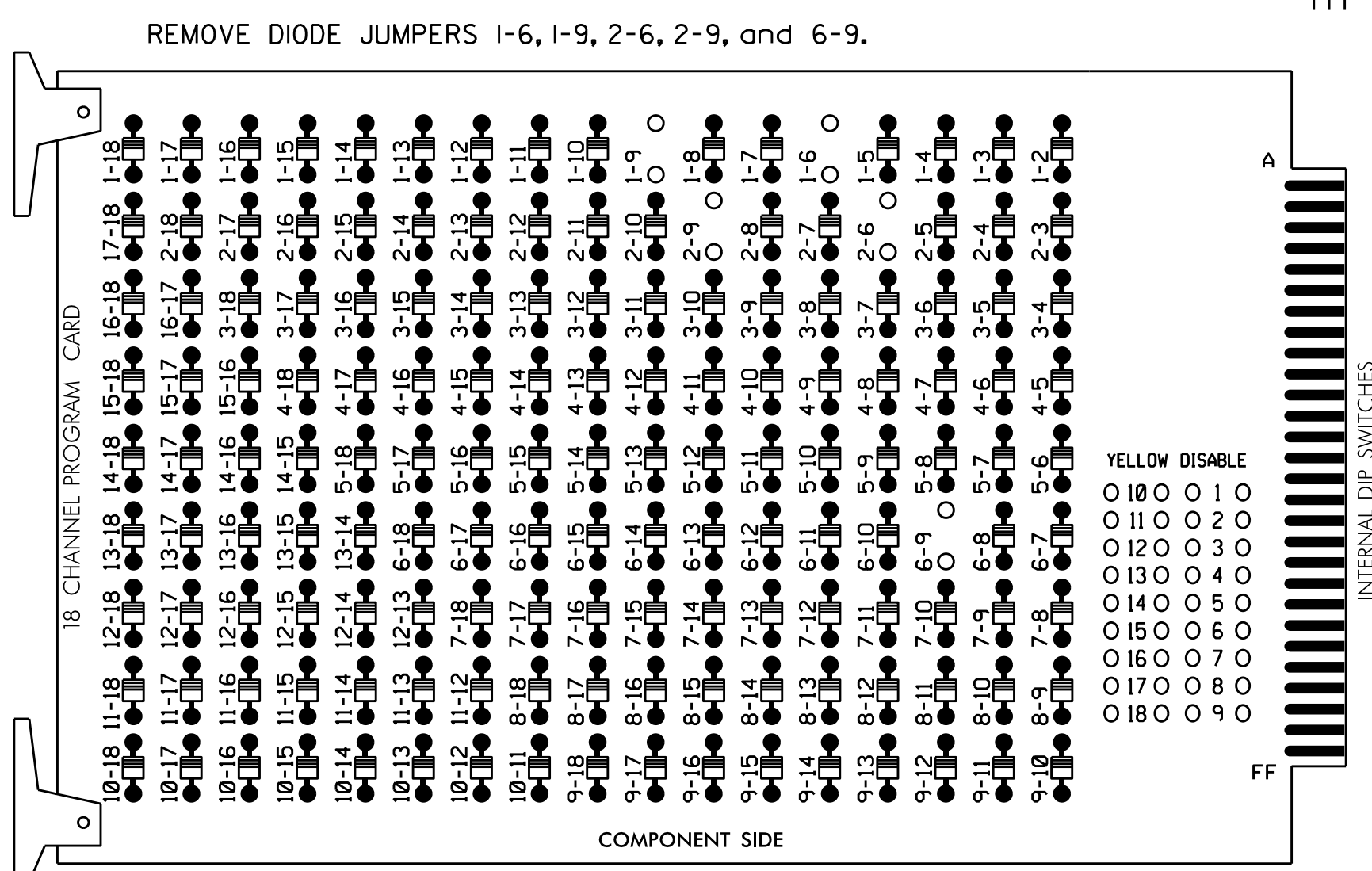

- NOTES:
- Card is provided with all diode jumpers in place. Removal of any jumper allows its channels to run concurrently.
 - Ensure jumpers SEL2-SEL5 and SEL9 are present on the monitor board.
 - Ensure that Red Enable is active at all times during normal operation.
 - Integrate monitor with Ethernet network in cabinet.

NOTES

- To prevent "flash-conflict" problems, insert red flash program blocks for all unused vehicle load switches in the output file. The installer shall verify that signal heads flash in accordance with the Signal Plans.
- Enable Simultaneous Gap-Out for all phases.
- Program phases 2 and 6 for Variable Initial and Gap Reduction.
- Program phases 2 and 6 for Start Up In Green.
- Program phases 2 and 6 for Yellow Flash, and overlap 1 as Wag Overlaps.
- The cabinet and controller are part of the Asheville Signal System.

EQUIPMENT INFORMATION

CONTROLLER.....2070E
 CABINET.....332 W/ AUX
 SOFTWARE.....ECONOLITE OASIS
 CABINET MOUNT.....BASE
 OUTPUT FILE POSITIONS...18 WITH AUX. OUTPUT FILE
 LOAD SWITCHES USED.....S1,S2,S5,S8,AUX S1
 PHASES USED.....1,2,4,6
 OVERLAP "A".....1+2
 OVERLAP "B".....NOT USED
 OVERLAP "C".....NOT USED
 OVERLAP "D".....NOT USED

SIGNAL HEAD HOOK-UP CHART

LOAD SWITCH NO.	S1	S2	S3	S4	S5	S6	S7	S8	S9	S10	S11	S12	AUX S1	AUX S2	AUX S3	AUX S4	AUX S5	AUX S6
CMU CHANNEL NO.	1	2	13	3	4	14	5	6	15	7	8	16	9	10	17	11	12	18
PHASE	1	2	2 PED	3	4	4 PED	5	6	6 PED	7	8	8 PED	OLA	OLB	SPARE	OLC	OLD	SPARE
SIGNAL HEAD NO.	11	42	21,22	NU	NU	22	41,42	NU	NU	61,62	NU	NU	11	NU	NU	NU	NU	NU
RED	*	128				101			134									
YELLOW		129				102			135									
GREEN		130				103			136									
RED ARROW													A121					
YELLOW ARROW		126				102							A122					
FLASHING YELLOW ARROW													A123					
GREEN ARROW	127	127				103												

NU = Not Used
 * Denotes install load resistor. See load resistor installation detail this sheet.
 ★ See pictorial of head wiring in detail below.

INPUT FILE POSITION LAYOUT
(front view)

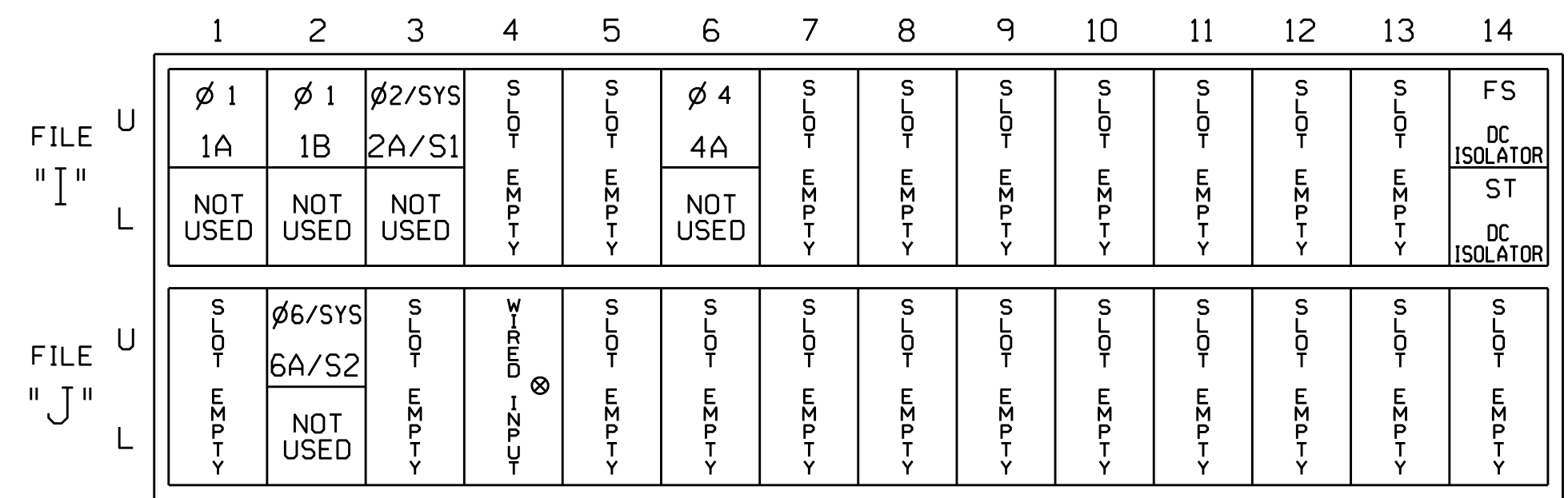

EX.: 1A, 2A, ETC. = LOOP NO.'S
 FS = FLASH SENSE
 ST = STOP TIME

⊗ Wired Input - Do not populate slot with detector card

INPUT FILE CONNECTION & PROGRAMMING CHART

LOOP NO.	LOOP TERMINAL	INPUT FILE POS.	PIN NO.	INPUT ASSIGNMENT NO.	DETECTOR NO.	NEMA PHASE	CALL	EXTEND	FULL TIME DELAY	STRETCH TIME	DELAY TIME
1A ¹	TB2-1,2	I1U	56	18	1	1	Y	Y			15
		J4U	48	10	26	6	Y	Y	Y		3
1B	TB2-5,6	I2U	39	1	2	1	Y	Y			15
2A/S1	TB2-9,10	I3U	63	25	32	2/SYS	Y	Y			
4A	TB4-9,10	I6U	41	3	4	4	Y	Y			3
6A/S2	TB3-5,6	J2U	40	2	6	6/SYS	Y	Y			

¹Add jumper from I1-W to J4-W, on rear of input file.

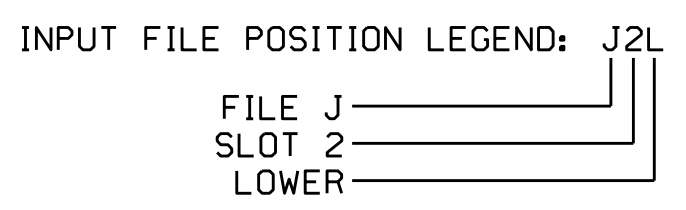

FYA SIGNAL WIRING DETAIL
(wire signal head as shown)

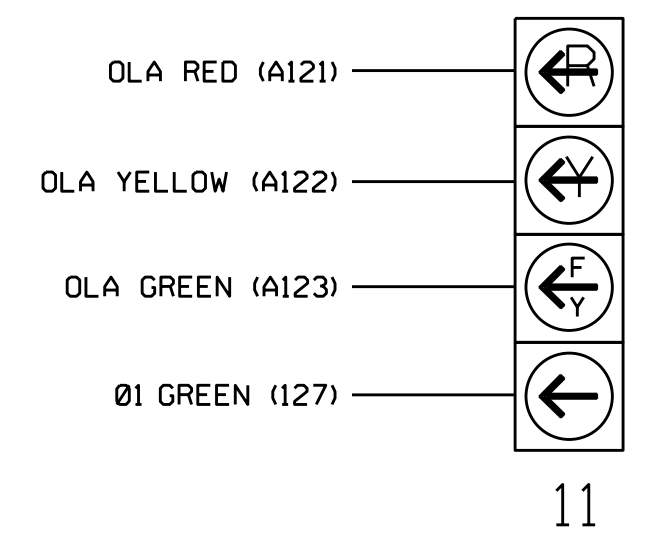

NOTE
 The sequence display for signal head 11 requires special logic programming. See sheet 2 for programming instructions.

LOAD RESISTOR INSTALLATION DETAIL
(install resistor as shown below)

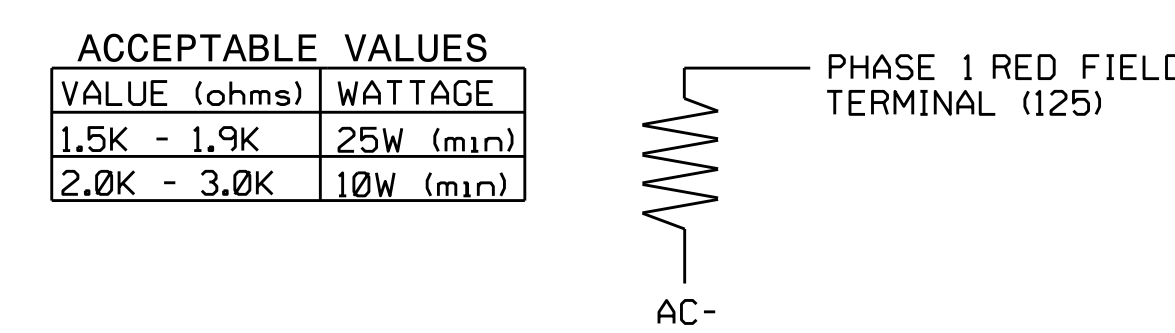

Prepared In the Offices of:
 TRANSPORTATION MOBILITY AND SAFETY ADMINISTRATION
 NORTH CAROLINA DEPARTMENT OF TRANSPORTATION
 Signal Management Section
 750 N. Greenfield Pkwy, Garner, NC 27529

US 74A/NC 81 (Swannanoa River Road) at US 74A (Fairview Road)

Division 13 Buncombe County Asheville

PLAN DATE: July 2016 REVIEWED BY: BAS

PREPARED BY: S. Armstrong REVIEWED BY:

REVISIONS INIT. DATE

DocuSigned by:
 Keith M. Mins 8/22/2016
 2F8078EBCD3445 DATE

SEAL
 NORTH CAROLINA PROFESSIONAL ENGINEER
 KEITH M. MINS
 036880

SIG. INVENTORY NO. 13-0288

09-AUG-2016 16:58
 S:\MITSAS\15_Signal\work\hgr\oups\51g_Minh\armstrong\30288_sm.ele.xxx.dgn
 armstrong