

EDI MODEL 2018EClip-NC CONFLICT MONITOR PROGRAMMING DETAIL

(remove jumpers and set switches as shown)

REMOVE DIODE JUMPERS 1-5, 1-6, 1-9, 1-11, 2-5, 2-6, 2-9, 2-11, 3-7, 3-8, 3-10, 3-12, 4-7, 4-8, 4-10, 4-12, 5-9, 5-11, 6-9, 6-11, 7-10, 7-12, 8-10, 8-12, 9-11 and 10-12.

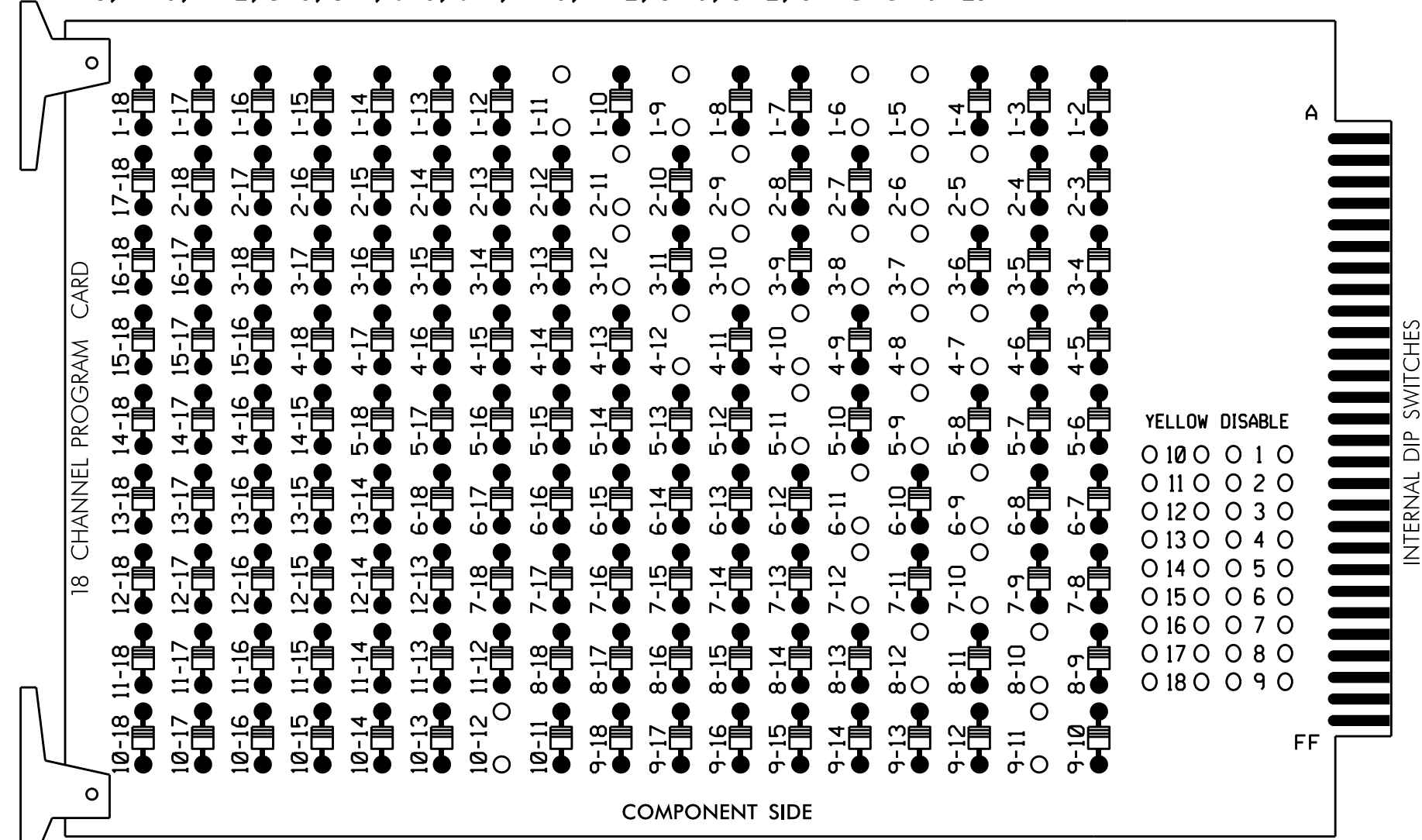

REMOVE JUMPERS AS SHOWN

NOTES:

- Card is provided with all diode jumpers in place. Removal of any jumper allows its channels to run concurrently.
- Ensure jumpers SEL2-SEL5 and SEL9 are present on the monitor board.
- Ensure that Red Enable is active at all times during normal operation.
- Integrate monitor with Ethernet network in cabinet.

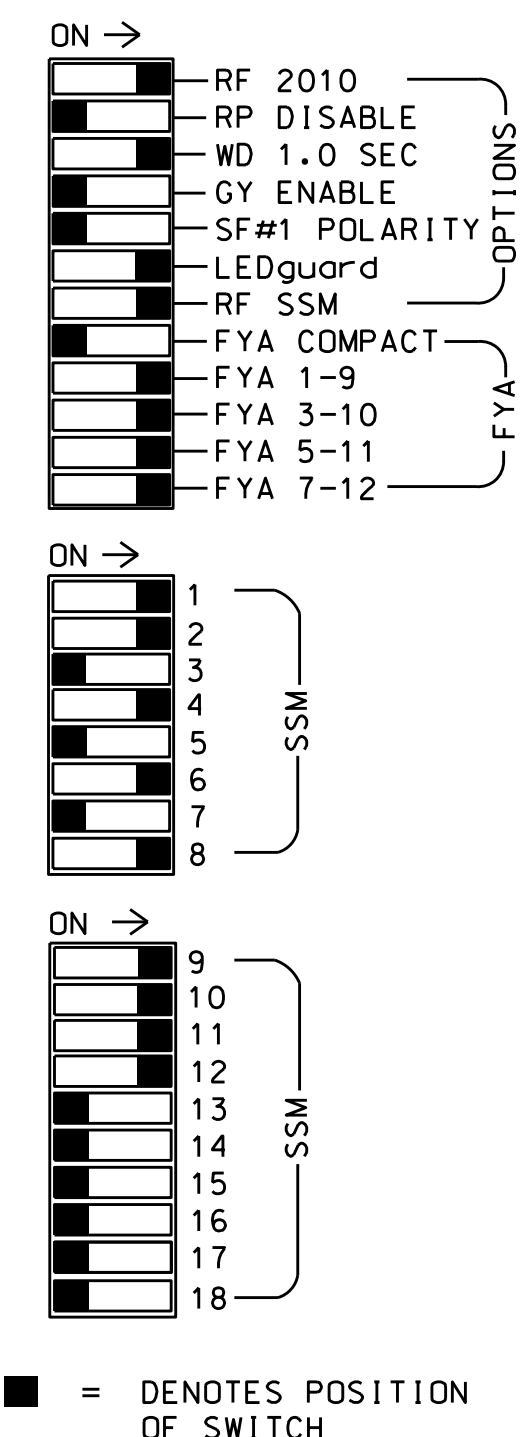
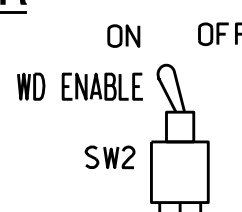

NOTES

- To prevent "flash-conflict" problems, insert red flash program blocks for all unused vehicle load switches in the output file. The installer shall verify that signal heads flash in accordance with the Signal Plans.
- Program phases 4 and 8 for Dual Entry.
- Enable Simultaneous Gap-Out for all phases.
- Program phases 2 and 6 for Variable Initial and Gap Reduction.
- Program phases 2 and 6 for Start Up In Green.
- Program phases 2 and 6 for Yellow Flash and overlaps 1 and 2 as Wag Overlaps.
- The cabinet and controller are part of the Asheville Signal System.

EQUIPMENT INFORMATION

CONTROLLER.....2070E
 CABINET.....332 W/ AUX
 SOFTWARE.....ECONOLITE OASIS
 CABINET MOUNT.....BASE
 OUTPUT FILE POSITIONS...18 WITH AUX. OUTPUT FILE
 LOAD SWITCHES USED.....S1,S2,S4,S5,S7,S8,S10,S11,
 AUX S1,AUX S2,AUX S4,AUX S5
 PHASES USED.....1,2,3,4,5,6,7,8
 OVERLAP "A".....1+2
 OVERLAP "B".....3+4
 OVERLAP "C".....5+6
 OVERLAP "D".....7+8

SIGNAL HEAD HOOK-UP CHART

LOAD SWITCH NO.	S1	S2	S3	S4	S5	S6	S7	S8	S9	S10	S11	S12	AUX S1	AUX S2	AUX S3	AUX S4	AUX S5	AUX S6	
CMU CHANNEL NO.	1	2	13	3	4	14	5	6	15	7	8	16	9	10	17	11	12	18	
PHASE	1	2	2 PED	3	4	4 PED	5	6	6 PED	7	8	8 PED	OLA	OLB	SPARE	OLC	OLD	SPARE	
SIGNAL HEAD NO.	11	82	21,22	NU	31	41,42	NU	51	61,62	NU	71	81,82	NU	11	31	NU	51	71	NU
RED	*	128			101			134			107								
YELLOW		129		*	102		*	135		*	108								
GREEN		130			103			136			109								
RED ARROW													A121	A124		A114	A101		
YELLOW ARROW		126											A122	A125		A115	A102		
FLASHING YELLOW ARROW													A123	A126		A116	A103		
GREEN ARROW	127	127			118			133			124								

NU = Not Used

* Denotes install load resistor. See load resistor installation detail this sheet.

★ See pictorial of head wiring in detail below.

4 SECTION FYA PPLT SIGNAL WIRING DETAIL

(wire signal heads as shown)

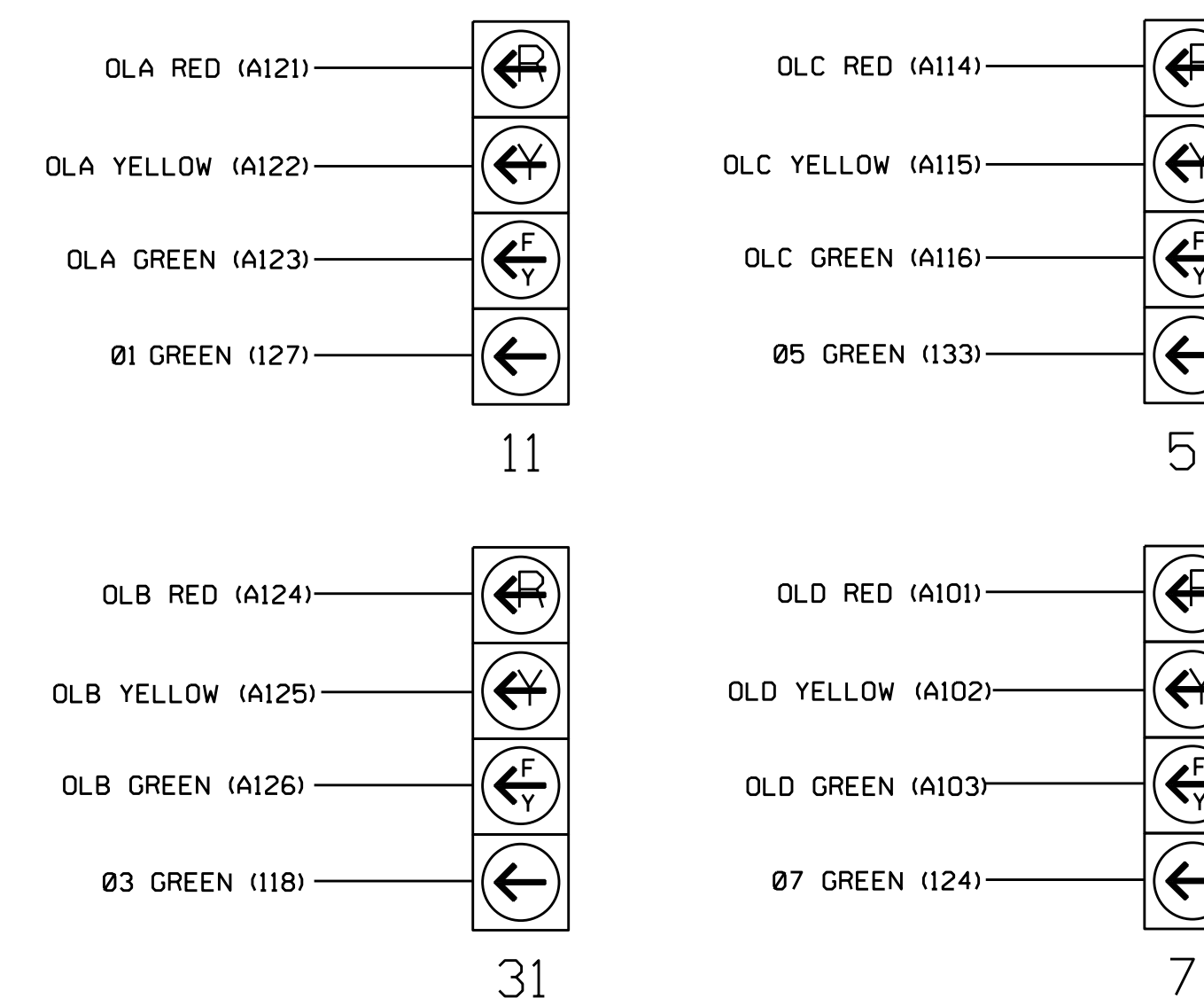

NOTE

- The sequence display for these signals require special logic programming. See sheet 2 for programming instructions.

INPUT FILE POSITION LAYOUT

(front view)

FILE "I"	1	2	3	4	5	6	7	8	9	10	11	12	13	14
U	∅ 1	∅ 1	∅ 3	∅ 4	∅ 5	∅ 6	∅ 7	∅ 8	SYS. DET. S1	S	S	S	S	FS
L	1A	1B	3A	4A	5A	6A	7A	8A	SYS. DET. S2	S	S	S	S	DC ISOLATOR
U	NOT USED	∅ 2	NOT USED	NOT USED	∅ 5	∅ 6	∅ 7	∅ 8	S	S	S	S	S	DC ISOLATOR
L	2A	2A	NOT USED	NOT USED	5A	6A	7A	8A	S	S	S	S	S	DC ISOLATOR

EX.: 1A, 2A, ETC. = LOOP NO.'S

FS = FLASH SENSE
 ST = STOP TIME

⊗ Wired Input - Do not populate slot with detector card

INPUT FILE CONNECTION & PROGRAMMING CHART

LOOP NO.	LOOP TERMINAL	INPUT FILE POS.	PIV NO.	INPUT ASSIGNMENT NO.	DETECTOR NO.	NEMA PHASE	CALL	EXTEND	FULL TIME DELAY	STRETCH TIME	DELAY TIME
1A ¹	TB2-1,2	I1U	56	18	1	1	Y	Y			15
	-	J4U	48	10	26	6	Y	Y	Y		3
1B	TB2-5,6	I2U	39	1	2	1	Y	Y			15
	2A	TB2-7,8	I2L	43	5	12	Y	Y			
3A ²	TB4-5,6	I5U	58	20	3	3	Y	Y			15
	-	J8U	50	12	28	8	Y	Y			3
4A	TB4-9,10	I6U	41	3	4	4	Y	Y			10
5A ³	TB3-1,2	J1U	55	17	5	5	Y	Y	Y		15
	-	I4U	47	9	22	2	Y	Y	Y		3
6A	TB3-5,6	J2U	40	2	6	6	Y	Y			
7A ⁴	TB5-5,6	J5U	57	19	7	7	Y	Y			15
	-	I8U	49	11	24	4	Y	Y			3
8A	TB5-9,10	J6U	42	4	8	8	Y	Y			
* S1	TB6-9,10	I9U	60	22	11	SYS					
* S2	TB6-11,12	I9L	62	24	13	SYS					

* System detector only. Remove the vehicle phase assigned to this detector in the default programming.

- Add jumper from I1-W to J4-W, on rear of input file.
- Add jumper from I5-W to J8-W, on rear of input file.
- Add jumper from J1-W to I4-W, on rear of input file.
- Add jumper from J5-W to I8-W, on rear of input file.

INPUT FILE POSITION LEGEND: J2L

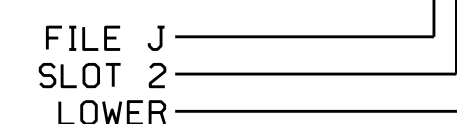

LOAD RESISTOR INSTALLATION DETAIL

(install resistors as shown below)

VALUE (ohms)	WATTAGE
1.5K - 1.9K	25W (min)
2.0K - 3.0K	10W (min)

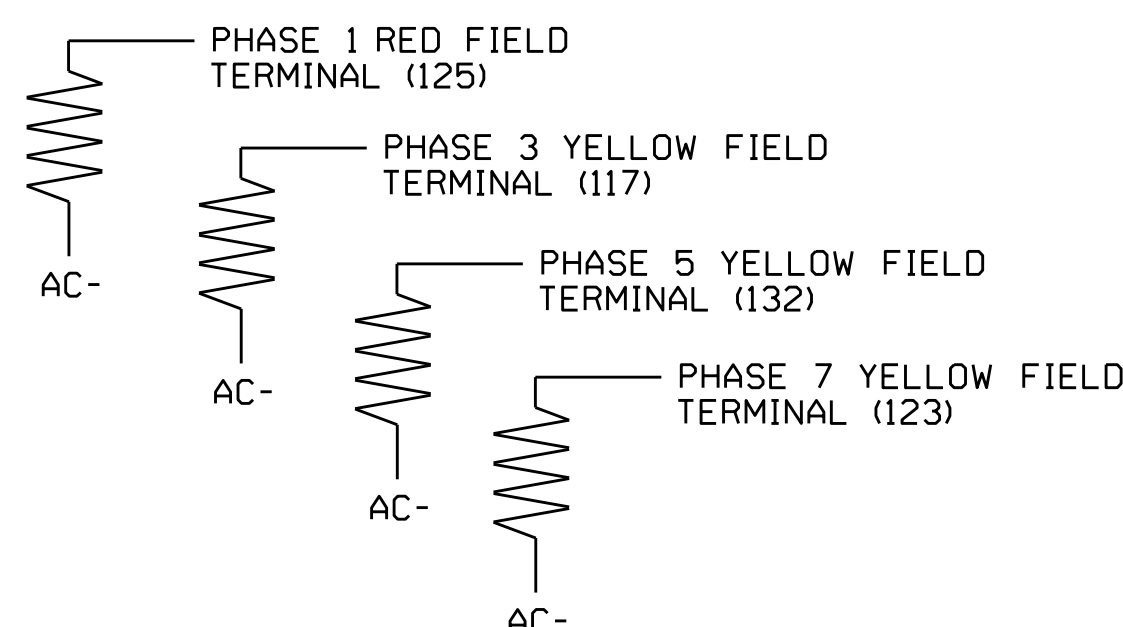

THIS ELECTRICAL DETAIL IS FOR THE SIGNAL DESIGN: 13-0286
 DESIGNED: February 2016
 SEALED: 9/7/2016
 REVISED:

Electrical Detail - Sheet 1 of 2

DOCUMENT NOT CONSIDERED FINAL UNLESS ALL SIGNATURES COMPLETED

Prepared In the Offices of:
 TRANSPORTATION MOBILITY AND SAFETY DIVISION
 NORTH CAROLINA DEPARTMENT OF TRANSPORTATION
 Signal Management Section
 750 N. Greenfield Pkwy, Garner, NC 27529

US 25A (Sweeten Creek Road) at SR 3116 (Mills Gap Road)

Division 13 Buncombe County Asheville
 PLAN DATE: September 2016 REVIEWED BY: T. Joyce
 PREPARED BY: C. Strickland REVIEWED BY:

REVISIONS INIT. DATE

DocuSigned by: *Cashy M. Little* 9/9/2016
 SIG. INVENTORY NO. 13-0286