

EDI MODEL 2018ECLIP-NC CONFLICT MONITOR
PROGRAMMING DETAIL

(remove jumpers and set switches as shown)

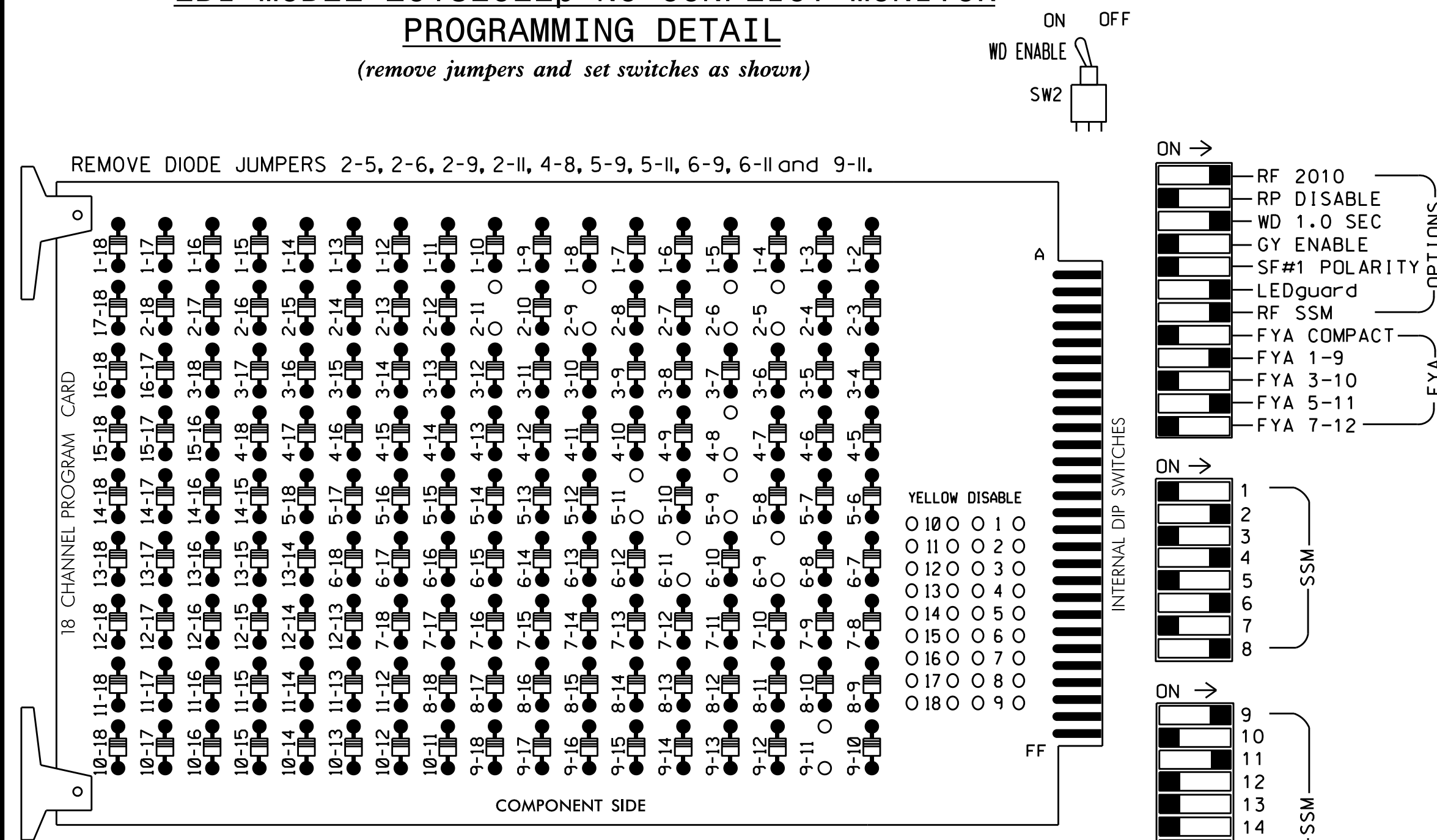

NOTES:

- Card is provided with all diode jumpers in place. Removal of any jumper allows its channels to run concurrently.
- Ensure jumpers SEL2-SEL5 and SEL9 are present on the monitor board.
- Ensure that Red Enable is active at all times during normal operation.
- Integrate monitor with Ethernet network in cabinet.

REMOVE JUMPERS AS SHOWN

■ = DENOTES POSITION OF SWITCH

NOTES

- To prevent "flash-conflict" problems, insert red flash program blocks for all unused vehicle load switches in the output file. The installer shall verify that signal heads flash in accordance with the Signal Plans.
- Program phases 4 and 8 for Dual Entry.
- Enable Simultaneous Gap-Out for all phases.
- Program phases 2 and 6 for Variable Initial and Gap Reduction.
- Program phases 2 and 6 for Start Up In Green.
- Program phases 2 and 6 for Yellow Flash, and overlap 1 as Wag Overlaps.
- The cabinet and controller are part of the Asheville Signal System.

EQUIPMENT INFORMATION

CONTROLLER.....2070E
 CABINET.....332 /W/ AUX
 SOFTWARE.....ECONOLITE OASIS
 CABINET MOUNT.....BASE
 OUTPUT FILE POSITIONS...18 WITH AUX. OUTPUT FILE
 LOAD SWITCHES USED.....S2,S5,S7,S8,S11,AUX S1,AUX S4.
 PHASES USED.....2,4,5,6,8.
 OVERLAP "A".....2
 OVERLAP "B".....NOT USED
 OVERLAP "C".....5+6
 OVERLAP "D".....NOT USED

SIGNAL HEAD HOOK-UP CHART

LOAD SWITCH NO.	S1	S2	S3	S4	S5	S6	S7	S8	S9	S10	S11	S12	AUX S1	AUX S2	AUX S3	AUX S4	AUX S5	AUX S6
CMU CHANNEL NO.	1	2	13	3	4	14	5	6	15	7	8	16	9	10	17	11	12	18
PHASE	1	2	2 PED	3	4	4 PED	5	6	6 PED	7	8	8 PED	OLA	OLB	SPARE	OLC	OLD	SPARE
SIGNAL HEAD NO.	NU	21,22	NU	NU	41,42	NU	51	62,63	NU	NU	81,82 83	NU	61	NU	NU	51	NU	NU
RED		128			101			134			107							
YELLOW		129			102		*	135			108							
GREEN		130			103			136			109							
RED ARROW													A121			A114		
YELLOW ARROW													A122			A115		
FLASHING YELLOW ARROW													A123			A116		
GREEN ARROW								133										

NU = Not Used

* Denotes install load resistor. See load resistor installation detail this sheet.

★ See pictorial of head wiring in detail below.

FYA SIGNAL WIRING DETAIL

(wire signal heads as shown)

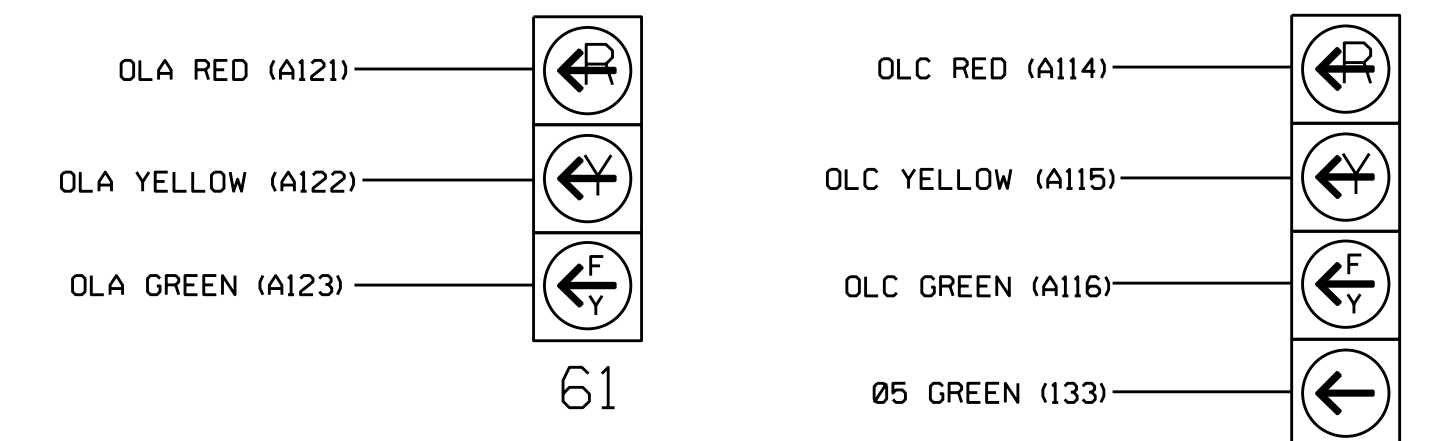

NOTE

- The sequence display for signal head 51 requires special logic programming. See sheet 2 for programming instructions.

INPUT FILE POSITION LAYOUT

(front view)

FILE "I"	1	2	3	4	5	6	7	8	9	10	11	12	13	14
U	∅2/SYS	∅2/SYS	∅2/SYS	∅2/SYS	∅2/SYS	∅4	∅2/SYS	∅2/SYS	∅2/SYS	∅2/SYS	∅2/SYS	∅2/SYS	∅2/SYS	∅2/SYS
L	2A/S1	2A/S1	2A/S1	2A/S1	2A/S1	4A	2A/S1	2A/S1	2A/S1	2A/S1	2A/S1	2A/S1	2A/S1	FS
	∅2/SYS	∅2/SYS	∅2/SYS	∅2/SYS	∅2/SYS	NOT USED	∅2/SYS	∅2/SYS	∅2/SYS	∅2/SYS	∅2/SYS	∅2/SYS	∅2/SYS	DC ISOLATOR
	2B/S2	2B/S2	2B/S2	2B/S2	2B/S2		2B/S2	2B/S2	2B/S2	2B/S2	2B/S2	2B/S2	2B/S2	DC ISOLATOR
U	∅5	∅6	∅6	∅2/SYS	∅2/SYS	∅8	∅2/SYS	∅2/SYS	∅2/SYS	∅2/SYS	∅2/SYS	∅2/SYS	∅2/SYS	S
L	5A	6A	6C	∅2/SYS	∅2/SYS	8A	∅2/SYS	∅2/SYS	∅2/SYS	∅2/SYS	∅2/SYS	∅2/SYS	∅2/SYS	∅2/SYS
	NOT USED	∅6	NOT USED	∅2/SYS	∅2/SYS	NOT USED	∅2/SYS	∅2/SYS	∅2/SYS	∅2/SYS	∅2/SYS	∅2/SYS	∅2/SYS	∅2/SYS
	6B	NOT USED	∅2/SYS	∅2/SYS	∅2/SYS	∅2/SYS	∅2/SYS	∅2/SYS	∅2/SYS	∅2/SYS	∅2/SYS	∅2/SYS	∅2/SYS	∅2/SYS

EX.: 1A, 2A, ETC. = LOOP NO.'S

FS = FLASH SENSE
 ST = STOP TIME

⊗ Wired Input - Do not populate slot with detector card

INPUT FILE CONNECTION & PROGRAMMING CHART

LOOP NO.	LOOP TERMINAL	INPUT FILE POS.	PIN NO.	INPUT ASSIGNMENT NO.	DETECTOR NO.	NEMA PHASE	CALL	EXTEND	FULL TIME DELAY	STRETCH TIME	DELAY TIME
2A/S1	TB2-5,6	I2U	39	1	2	2/SYS	Y	Y			
2B/S2	TB2-7,8	I2L	43	5	12	2/SYS	Y	Y			
4A	TB4-9,10	I6U	41	3	4	4	Y	Y			
5A ¹	TB3-1,2	J1U	55	17	5	5	Y	Y			10
	-	I4U	47	9	22	2	Y	Y	Y		15
6A	TB3-5,6	J2U	40	2	6	6	Y	Y			
6B	TB3-7,8	J2L	44	6	16	6	Y	Y			
6C	TB3-9,10	J3U	64	26	36	6	Y	Y			
8A	TB5-9,10	J6U	42	4	8	8	Y	Y			10

¹Add jumper from J1-W to I4-W, on rear of input file.

INPUT FILE POSITION LEGEND:

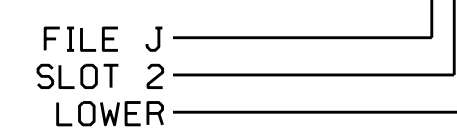

LOAD RESISTOR INSTALLATION DETAIL

(install resistors as shown below)

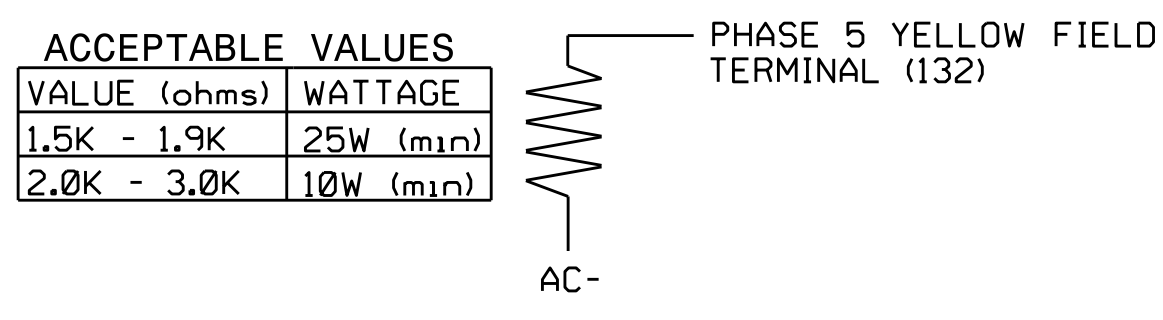

ELECTRICAL DETAIL SHEET 1 OF 2

DOCUMENT NOT CONSIDERED FINAL UNLESS ALL SIGNATURES COMPLETED

Prepared In the Offices of:
 Transportation Mobility and Safety Solutions
 750 N. Greenfield Pkwy, Garner, NC 27529

NC 63 at Old County Home Rd./Evelake Dr.
 Division 18 Buncombe County Asheville

PLAN DATE: May 2016 REVIEWED BY: DTJ
 PREPARED BY: James Peterson REVIEWED BY:

REVISIONS INIT. DATE

DocuSigned by:
 Keith M. Mins 9/13/2016

SIG. INVENTORY NO. 13-0037