

NOTES

STIRRUPS IN CAP MAY BE SHIFTED AS NECESSARY TO CLEAR DOWELS.

THE CONCRETE IN THE SHADED AREA OF THE WING SHALL BE POURED AFTER THE CONCRETE PARAPET IS CAST IF SLIP FORMING IS USED.

FOR PILE SPLICE DETAILS, SEE SHEET 4 OF 4.

FOR WING DETAILS, SEE SHEET 3 OF 4.

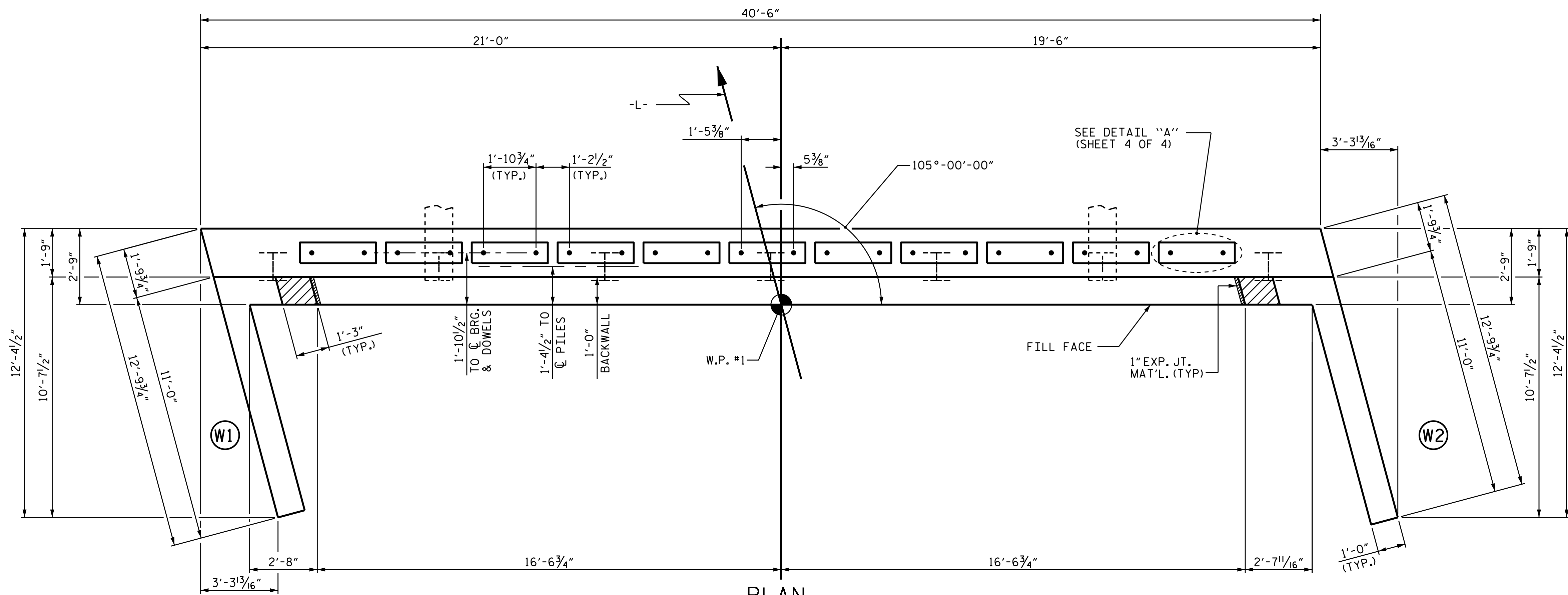

PLAN

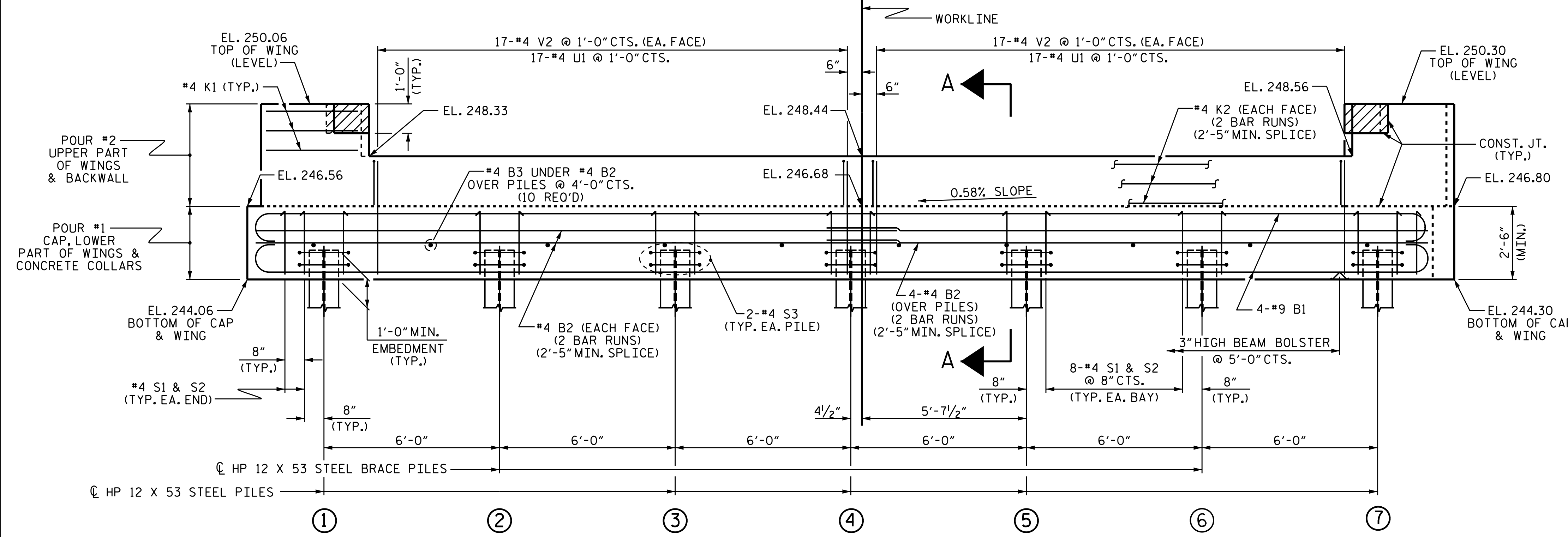

ELEVATION

TOP OF PILE ELEVATIONS	
①	245.08
②	245.11
③	245.14
④	245.18
⑤	245.22
⑥	245.25
⑦	245.29

PROJECT NO. B-4655
WAKE COUNTY
 STATION: 18+35.50 -L-

SHEET 1 OF 4

STATE OF NORTH CAROLINA
 DEPARTMENT OF TRANSPORTATION
 RALEIGH

SUBSTRUCTURE
 END BENT 1

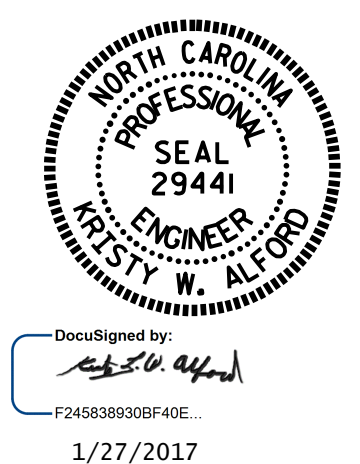

ASSEMBLED BY : M.M. AHMED DATE : 10-5-16
 CHECKED BY : J. P. ADAMS DATE : 10-28-16
 DRAWN BY : WJH 12/11 REV. 4/15 MAA/TMG
 CHECKED BY : AAC 12/11

WINGS NOT SHOWN FOR CLARITY.
 FOR SECTION A-A, SEE SHEET 4 OF 4.
 CONCRETE COLLARS FOR STEEL PILES NOT SHOWN IN PLAN AND ELEVATION VIEWS FOR CLARITY.
 SEE "CORROSION PROTECTION FOR STEEL PILES DETAIL", SHEET 4 OF 4.

DOCUMENT NOT CONSIDERED
 FINAL UNLESS ALL
 SIGNATURES COMPLETED

REVISIONS						SHEET NO.	
NO.	BY:	DATE:	NO.	BY:	DATE:	S-13	
1			3			TOTAL SHEETS 18	
2			4				