

NOTES

STIRRUPS IN CAP MAY BE SHIFTED AS NECESSARY TO CLEAR DOWELS.

THE CONCRETE IN THE SHADED AREA OF THE WING SHALL BE POURED AFTER THE VERTICAL CONCRETE BARRIER RAIL IS CAST IF SLIP FORMING IS USED.

FOR PILE SPLICE DETAILS, SEE SHEET 4 OF 4.

FOR WING DETAILS, SEE SHEET 3 OF 4.

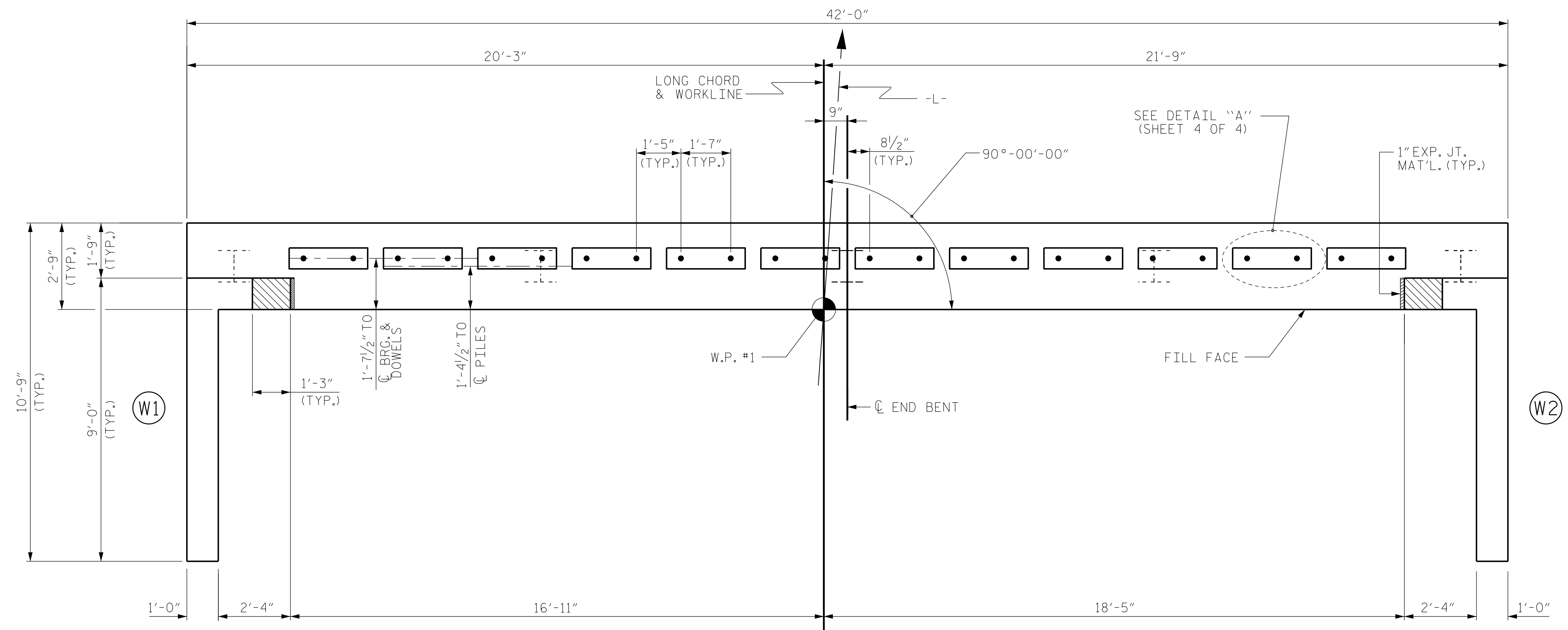

PLAN

TOP OF PILE ELEVATIONS	
①	131.61
②	132.00
③	132.39
④	132.78
⑤	133.17

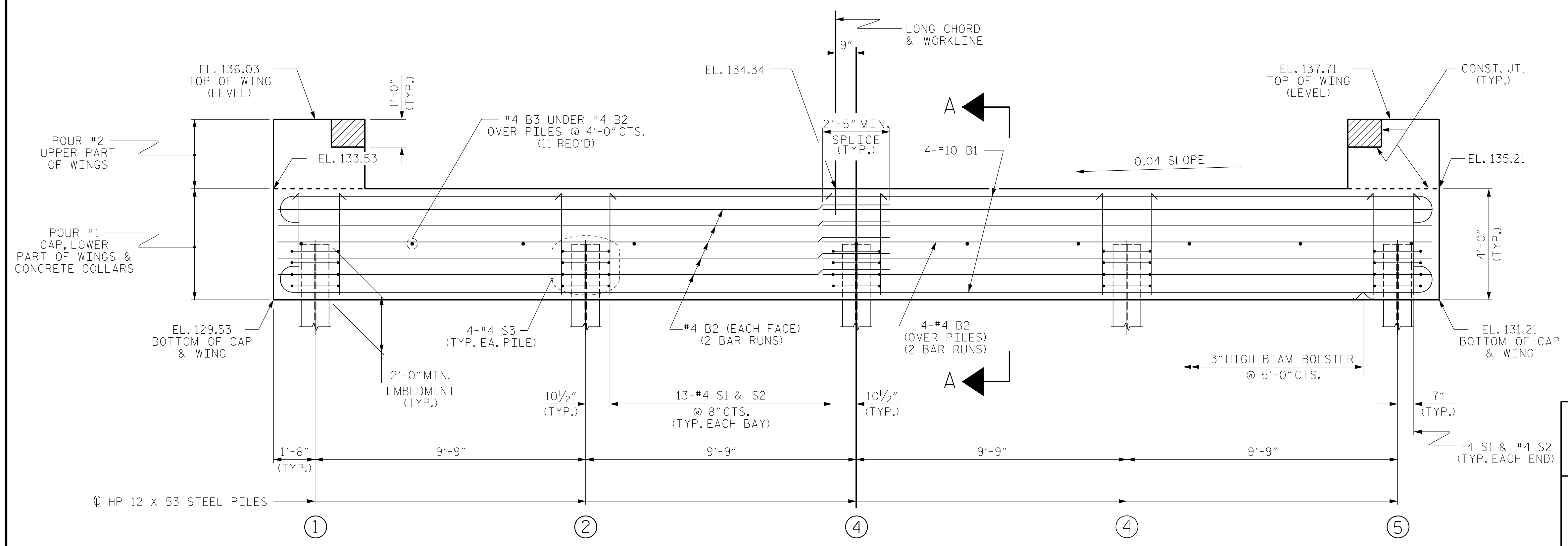

ELEVATION

WINGS NOT SHOWN FOR CLARITY.
 FOR SECTION A-A, SEE SHEET 4 OF 4.
 CONCRETE COLLARS FOR STEEL PILES NOT SHOWN IN PLAN AND ELEVATION VIEWS FOR CLARITY.
 SEE "CORROSION PROTECTION FOR STEEL PILES DETAIL", SHEET 4 OF 4.

PROJECT NO. B-5333

ROBESON COUNTY

STATION: 37+28.50 -L-

SHEET 1 OF 4 BRIDGE NO. 174

Dewberry
 2610 WYCLIFF ROAD
 SUITE 410
 RALEIGH, NC 27607
 PHONE: 919.881.9939
 NC COA No. F-0929

12/9/2016
 ENGINEER
 JENNIFER R. MEROY
 SEAL 032076

DocuSigned by:
 Jennifer R. Meroy
 E1140791288475

REVISIONS						SHEET No.
No.	BY:	DATE:	No.	BY:	DATE:	S02-15
1			3			TOTAL SHEETS
2			4			23

12/9/2016 8:47:36 AM EBT1.dgn
 USER: jmeroy

DRAWN BY: MTB DATE: 04/16
 CHECKED BY: JRM DATE: 04/16