

STATE	PROJECT NO.	SHEET NO.	TOTAL SHEETS
N.C.	2017CPT.10.10.10131.1	10	
F.A. PROJECT NO.			

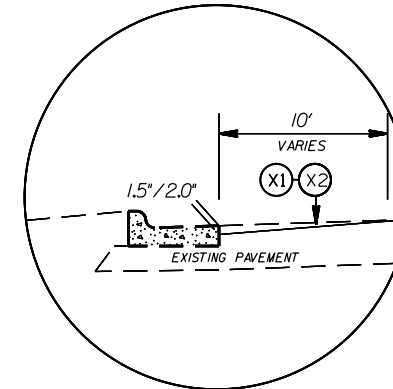

DETAIL FOR PROFILE MILLING (0" TO 1.5")
 DETAIL FOR PROFILE MILLING (0" TO 2.0")

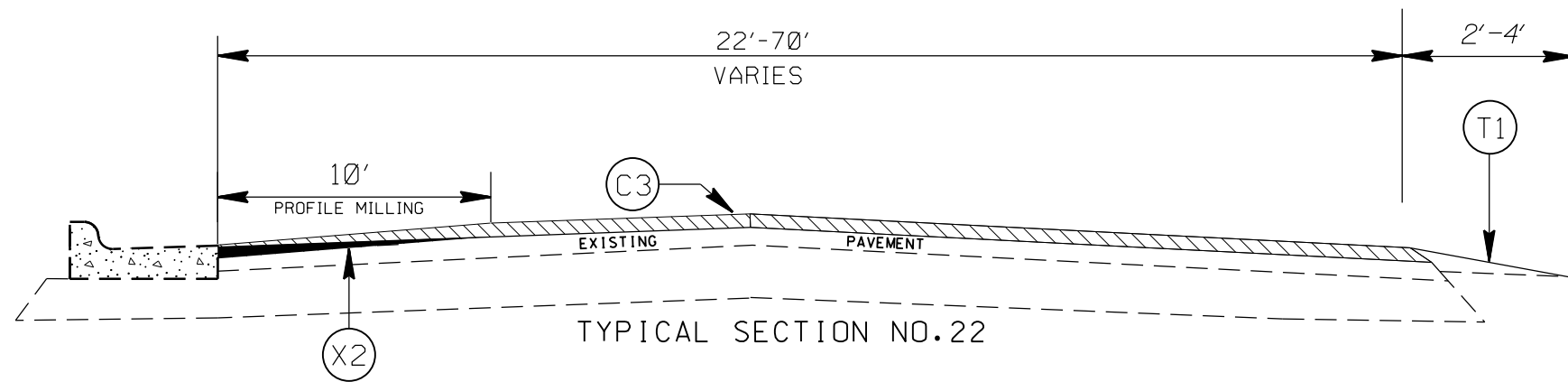
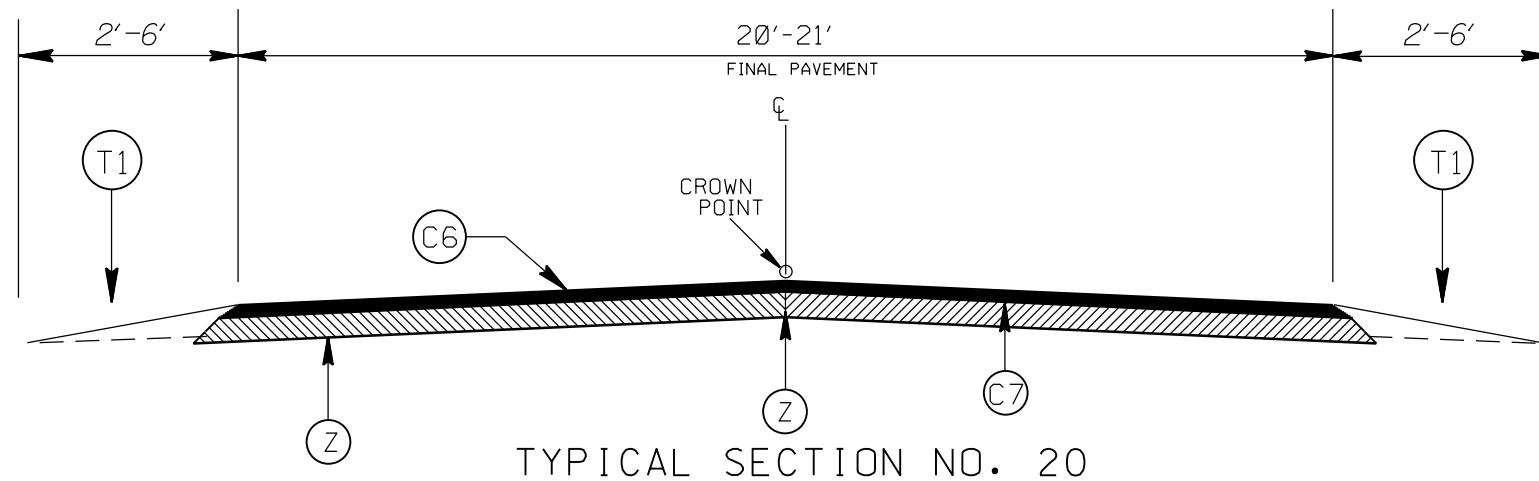
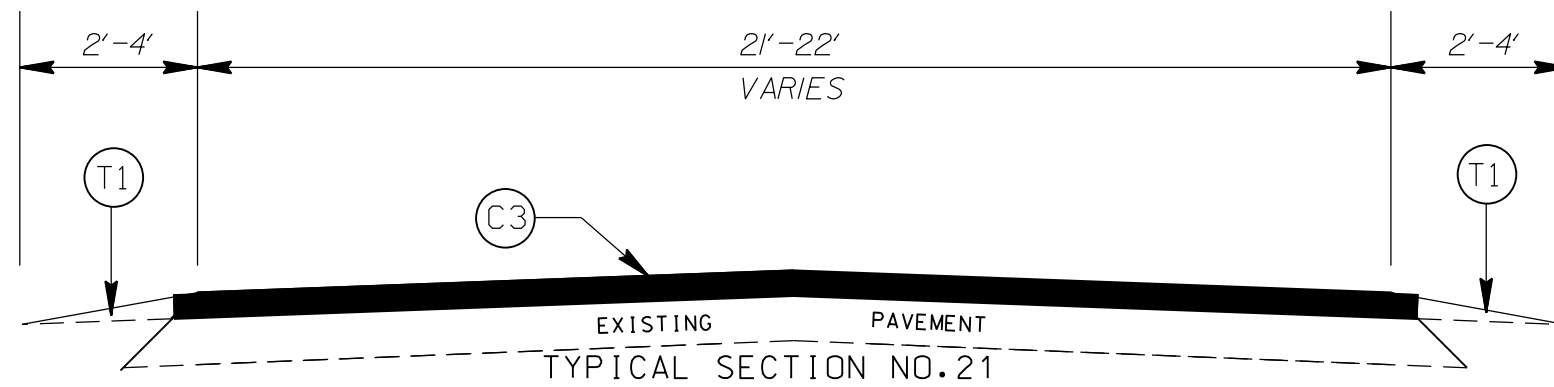
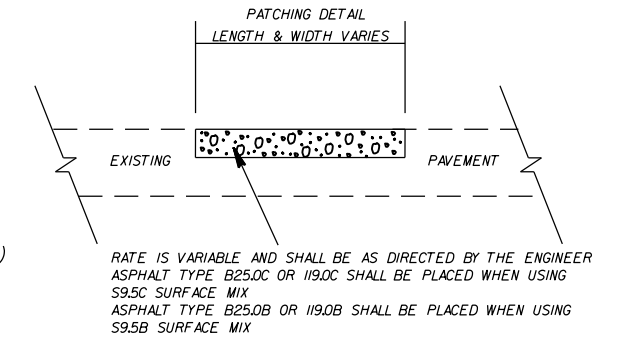

PAVEMENT SCHEDULE	
C1	PROP. APPROX. 2.0" ASPHALT CONCRETE SURFACE COURSE, TYPE S9.5C, AT AN AVERAGE RATE OF 224 LBS. PER SQ. YD.
C2	PROP. APPROX. 1.5" ASPHALT CONCRETE SURFACE COURSE, TYPE S9.5C, AT AN AVERAGE RATE OF 168 LBS. PER SQ. YD.
C3	PROP. APPROX. 1.5" ASPHALT CONCRETE SURFACE COURSE, TYPE S9.5B, AT AN AVERAGE RATE OF 168 LBS. PER SQ. YD.
C4	PROP. APPROX. 2.0" ASPHALT CONCRETE SURFACE COURSE, TYPE S9.5B AT AN AVERAGE RATE OF 224 LBS. PER SQ. YD.
C5	PROP. APPROX. 1.0" ASPHALT CONCRETE SURFACE COURSE, TYPE SF9.5A, AT AN AVERAGE RATE OF 110 LBS. PER SQ. YD.
C6	PROP. APPROX. 3" ASPHALT CONCRETE SURFACE COURSE, TYPE S9.5B, AT AN AVERAGE RATE OF 168 LBS. PER SQ. IN EACH OF TWO LAYERS
C7	PROP. AST DOUBLE SEAL, THE FIRST COAT SHALL BE APPLIED FOR BOTH LANES AT THE END OF DAY TWO (2) RECLAMATION. THE FINAL SEAL BE APPLIED AFTER RECLAMATION OF THE MAP IS COMPLETE.
D1	AST MAT COAT # 67
D2	MAT COAT # 78M
T1	SHOULDER RECONSTRUCTION
V1	MILLING BITUMINOUS PAVEMENT 2.0" DEPTH, AS DIRECTED BY THE ENGINEER
V2	MILLING BITUMINOUS PAVEMENT 1.5" DEPTH.
X1	PROFILE MILLING BITUMINOUS PAVEMENT, 0" TO 1.5"
X2	PROFILE MILLING BITUMINOUS PAVEMENT, 0" TO 2.0"
Z	FULL DEPTH RECLAMATION

CABARRUS COUNTY
 RESURFACING 2017-2018

SCALE	-NA-		REVISIONS
DATE	1/17		
DWG. BY	JDA		
DESIGN BY	JDA		
APPROVED	MPM		